

# STR-M6529

## OFF-LINE SWITCHING REGULATOR - WITH POWER MOSFET OUTPUT

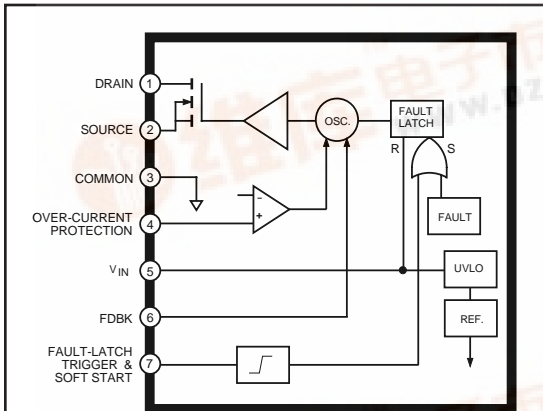

Dwg. PK-002

### ABSOLUTE MAXIMUM RATINGS

Supply Voltage, $V_{IN}$ .....	<b>35 V</b>
Drain-Source Voltage, $V_{DS}$ .....	<b>800 V</b>
Continuous Drain Current, $I_D$ .....	<b>5.4 A</b>
1 ms Single-Pulse Drain Current, $I_{DM}$ .....	<b>20 A</b>
Single-Pulse Avalanche Energy, $E_A$ .....	<b>400 mJ</b>
Soft-Start/Fault-Latch Trig. Voltage, $V_{SS/FL}$ .....	<b>12 V</b>
Feedback Input Current, $I_{FDBK}$ .....	<b>20 mA</b>
Over-Current Protection Voltage, $V_{OCP}$ .....	<b>3.5 V</b>
Insulation Voltage, $V_{WM(RMS)}$ .....	<b>2000 V</b>
Package Power Diss., $P_D$ .....	<b>See Graph</b>
FET Junction Temperature, $T_J$ .....	<b>+150°C</b>
Internal Frame Temperature, $T_F$ ...	<b>+125°C</b>
Operating Temperature Range, $T_A$ .....	<b>-20°C to +125°C</b>
Storage Temperature Range, $T_{STG}$ .....	<b>-40°C to +125°C</b>

The STR-M6529 is specifically designed to meet the requirement for increased integration and reliability in off-line flyback converters operating in the quasi-resonant ringing choke mode. The device incorporates the primary control and drive circuit with a discrete avalanche-rated high-voltage power MOSFET.

Crucial system parameters such as maximum ON time and OFF time are fixed during manufacture. Local control circuit decoupling and layout are optimized within the device.

Cycle-by-cycle current limiting, soft start, under-voltage lock-out with hysteresis, over-voltage protection, and thermal shutdown protect the devices during all normal and overload conditions. Over-voltage protection, thermal shutdown, or an external fault signal are latched. The dual requirements of dielectric isolation and low transient thermal impedance and steady-state thermal resistance are satisfied in an over-molded single-in-line power package.

Proven in substantial volumes, this device and its fixed-frequency counterparts represents a significant advance in off-line SMPS reliability growth and integration.

### FEATURES

- Quasi-Resonant Ringing Choke Converter
- Avalanche-Rated Power MOSFET Switch
- Pulse-by-Pulse Current Limiting
- Latched Over-Voltage and Thermal Protection
- Maximum ON Time and OFF Time Set During Manufacture
- Internal Under-Voltage Lockout with Hysteresis
- Over-Molded SIP with Integral Isolated Heat Spreader

Always order by complete part number: **STR-M6529** .

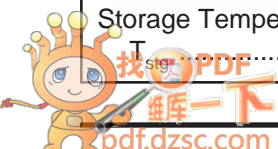

# STR-M6529 OFF-LINE SWITCHING REGULATOR

## FUNCTIONAL BLOCK DIAGRAM

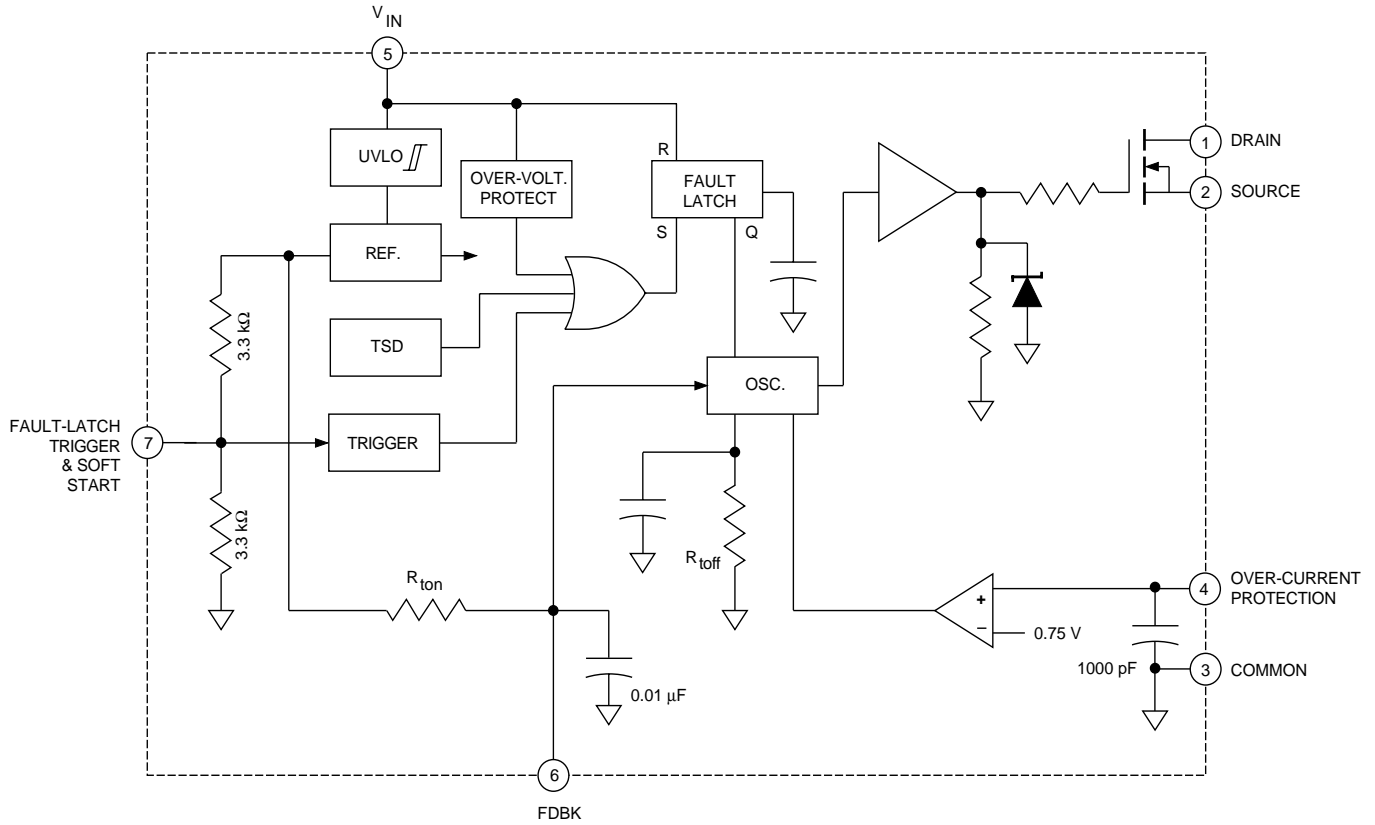

Dwg. FK-002-2

## ALLOWABLE PACKAGE POWER DISSIPATION

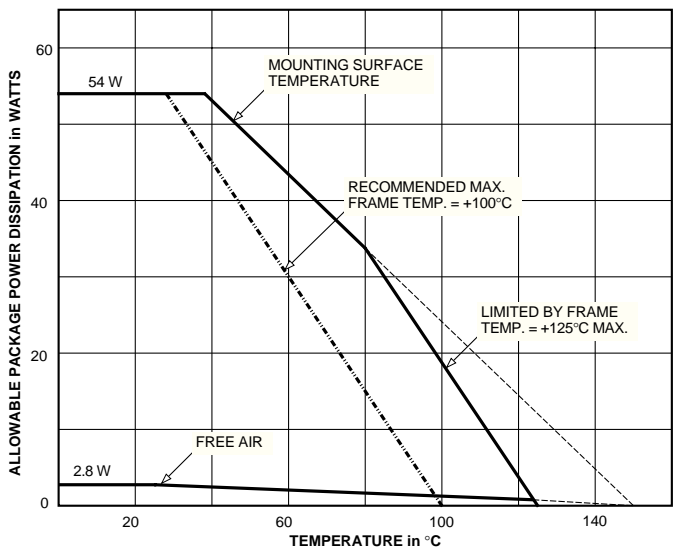

Dwg. GK-003-1

## MAXIMUM SAFE OPERATING AREA

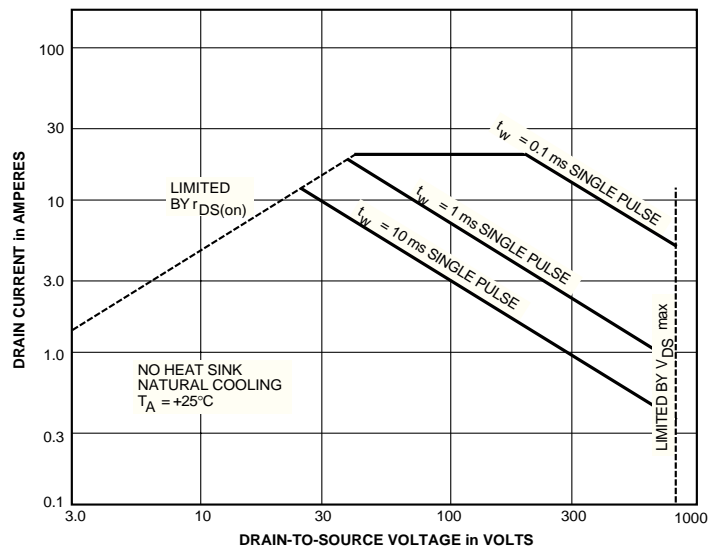

Dwg. GK-004-1

# STR-M6529

## OFF-LINE SWITCHING REGULATOR

### ALLOWABLE AVALANCHE ENERGY

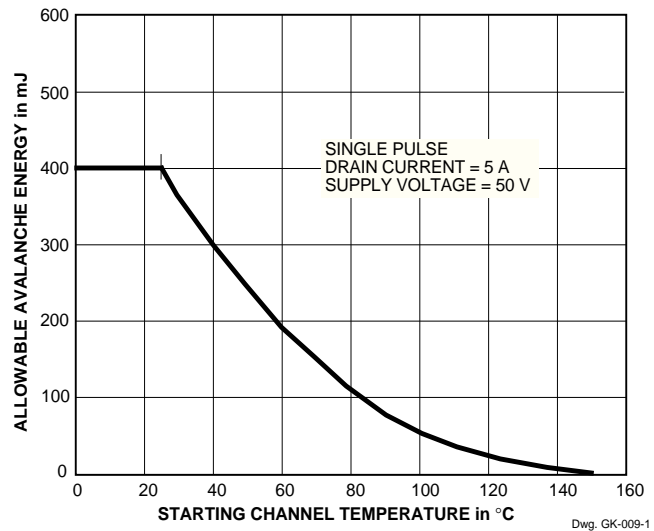

**ELECTRICAL CHARACTERISTICS** at  $T_A = +25^\circ\text{C}$ ,  $V_{IN} = 18\text{ V}$ , voltage measurements are referenced to Common (pin 3) (unless otherwise noted).

Characteristic	Symbol	Test Conditions	Limits			Units
			Min.	Typ.	Max.	
On-State Voltage	$V_{INT}$	Turn-on, increasing $V_{IN}$	14.4	–	17.6	V
Under-Voltage Lockout	$V_{INQ}$	Turn-off, decreasing $V_{IN}$	9.0	–	11	V
Over-Voltage Threshold	$V_{OVP(th)}$		26	–	31	V
FET Leakage Current	$I_{DSS}$	$V_{DS} = 800\text{ V}$	–	–	300	$\mu\text{A}$
FET ON Resistance	$r_{DS(on)}$	$V_{GS} = 10\text{ V}$ , $I_D = 2.5\text{ A}$	–	1.8	2.2	$\Omega$
Output Fall Time	$t_f$	$V_{DD} = 250\text{ V}$ , $I_D = 2.5\text{ A}$ , 10% to 90% $V_{DS}$	–	–	250	ns
Maximum ON Time	$t_{on}$		22.5	–	27.5	$\mu\text{s}$
Minimum OFF Time	$t_{off}$		2.0	–	4.0	$\mu\text{s}$
Over-Current Threshold	$V_{OCP(th)}$		700	–	800	mV
Feedback Threshold	$V_{FDBK(th)}$		–	750	–	mV
Soft-Start Current	$I_{SS}$	$V_{SS} = 0\text{ V}$	-2.2	–	-3.4	mA
Fault-Latch Threshold Volt.	$V_{FL(th)}$		8.0	–	9.2	V
Fault-Latch Holding Current	$I_{INH}$	$V_{IN}$ reduced to 8.5 V	–	340	400	$\mu\text{A}$
Fault-Latch Reset Voltage	$V_{INQ}$	$I_{IN} < 20\ \mu\text{A}$ , $V_{IN}$ reduced from 31 V	6.5	–	8.5	V
Insulation RMS Voltage	$V_{WM(RMS)}$	All terminals simultaneous reference metal plate against backside	2000	–	–	V
Supply Current	$I_{IN(ON)}$	Operating	16	–	26	mA
	$I_{IN(OFF)}$	Start up, $V_{IN} = 14\text{ V}$	–	–	100	$\mu\text{A}$
Thermal Shutdown	$T_J$		125	150	–	$^\circ\text{C}$
Thermal Resistance	$R_{\theta JM}$	FET junction to mounting surface	–	2.0	–	$^\circ\text{C/W}$

NOTES: Negative current is defined as coming out of (sourcing) the specified device terminal.  
Typical Data is for design information only.

# STR-M6529 OFF-LINE SWITCHING REGULATOR

## TYPICAL APPLICATION

**WARNING:** lethal potentials are present. See text.

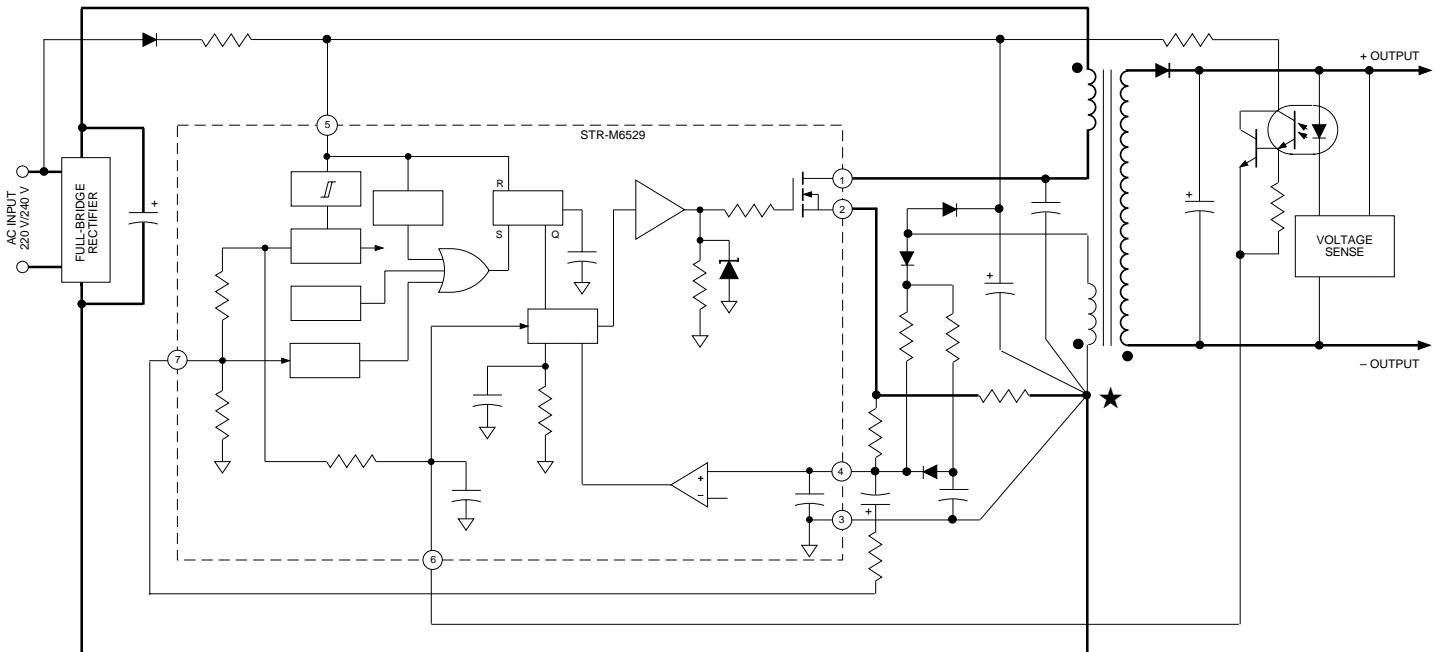

Dwg. EK002-1

## APPLICATIONS INFORMATION

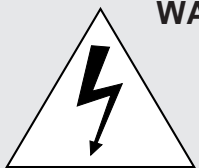

**WARNING** — These devices are designed to be operated at lethal voltages and energy levels. Circuit designs that embody these components must conform with applicable safety requirements. Precautions must be taken to prevent accidental contact with power-line potentials. Do not connect grounded test equipment. The use of an isolation transformer is recommended during circuit development and breadboarding.

The power MOSFET outputs of these devices are similar to the International Rectifier type IRFPE40. These devices feature an excellent combination of fast switching, ruggedized device design, low on-resistance, and cost effectiveness.

Recommended mounting hardware torque:  
4.34 – 5.79 lbf•ft (6 – 8 kg•cm or 0.588 – 0.784 Nm).

Recommended metal-oxide-filled, alkyl-degenerated oil base, silicone grease:  
Dow Corning 340, or equivalent

**STR-M6529**  
**OFF-LINE**  
**SWITCHING REGULATOR**

**Dimensions in Inches**  
**(for reference only)**

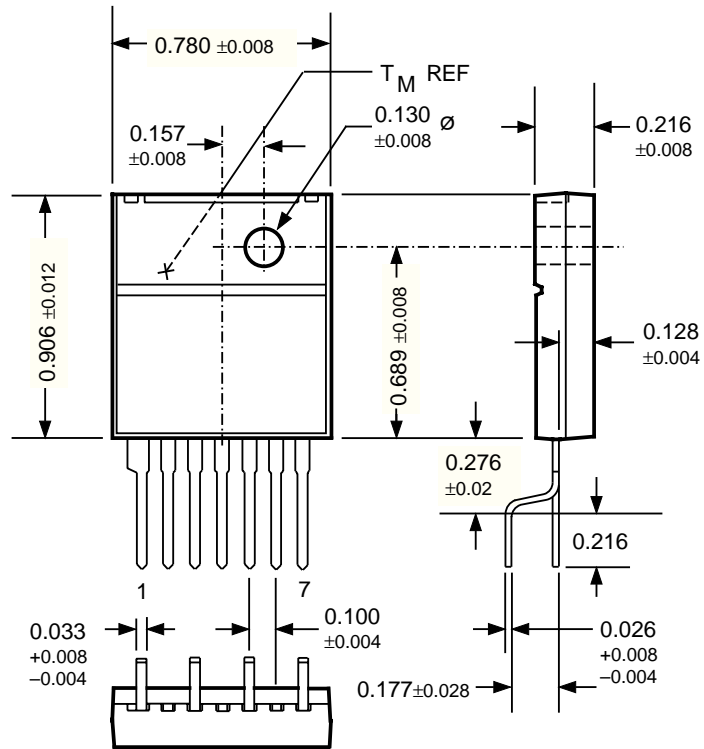

Dwg. MK-003-7 in

NOTE: Exact body and lead configuration at vendor's option within limits shown.

# STR-M6529

## OFF-LINE

### SWITCHING REGULATOR

#### Dimensions in Millimeters (controlling dimensions)

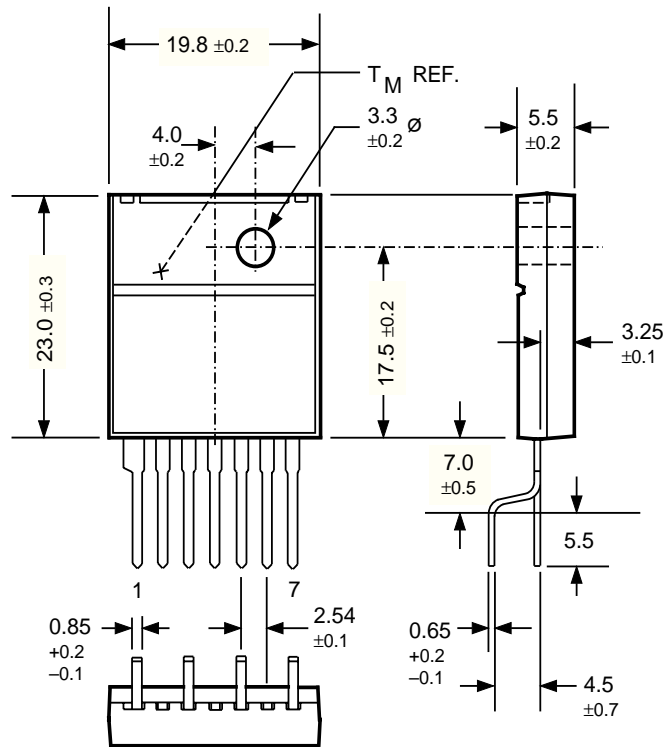

Dwg. MK-003-7 mm

NOTE: Exact body and lead configuration at vendor's option within limits shown.

The products described here are manufactured in Japan by Sanken Electric Co., Ltd. for sale by Allegro MicroSystems, Inc.

Sanken Electric Co., Ltd. and Allegro MicroSystems, Inc. reserve the right to make, from time to time, such departures from the detail specifications as may be required to permit improvements in the design of their products.

The information included herein is believed to be accurate and reliable. However, Sanken Electric Co., Ltd. and Allegro MicroSystems, Inc. assume no responsibility for its use; nor for any infringements of patents or other rights of third parties which may result from its use.