

[查询ZHX1200供应商](#)

[捷多邦，专业PCB打样工厂，24小时加急出货](#)



ZHX1200

**Low-Power SIR (IrMC)
Transceiver**

Product Specification

PS007110-0802





This publication is subject to replacement by a later edition. To determine whether a later edition exists, or to request copies of publications, contact:

ZiLOG Worldwide Headquarters

532 Race Street
San Jose, CA 95126-3432
Telephone: 408.558.8500
Fax: 408.558.8300
www.ZiLOG.com

ZiLOG is a registered trademark of ZiLOG Inc. in the United States and in other countries. All other products and/or service names mentioned herein may be trademarks of the companies with which they are associated.

Document Disclaimer

©2002 by ZiLOG, Inc. All rights reserved. Information in this publication concerning the devices, applications, or technology described is intended to suggest possible uses and may be superseded. ZiLOG, INC. DOES NOT ASSUME LIABILITY FOR OR PROVIDE A REPRESENTATION OF ACCURACY OF THE INFORMATION, DEVICES, OR TECHNOLOGY DESCRIBED IN THIS DOCUMENT. ZiLOG ALSO DOES NOT ASSUME LIABILITY FOR INTELLECTUAL PROPERTY INFRINGEMENT RELATED IN ANY MANNER TO USE OF INFORMATION, DEVICES, OR TECHNOLOGY DESCRIBED HEREIN OR OTHERWISE. Devices sold by ZiLOG, Inc. are covered by warranty and limitation of liability provisions appearing in the ZiLOG, Inc. Terms and Conditions of Sale. ZiLOG, Inc. makes no warranty of merchantability or fitness for any purpose. Except with the express written approval of ZiLOG, use of information, devices, or technology as critical components of life support systems is not authorized. No licenses are conveyed, implicitly or otherwise, by this document under any intellectual property rights.



Table of Contents

Description	1
Features	1
Block Diagram	2
Pin Description	4
VCC Positive Supply	4
GND Ground	4
TAB	4
TXD Transmit Data	4
RXD Receive Data	5
SD Shutdown	5
LEDA IRED Driver Anode	5
Electrical and Timing Specifications	5
Transceiver Performance	8
Mechanical Specifications	11
Recommended Soldering Conditions	13
Packing, Storing, and Baking Recommendations	14
Moisture Prevention Guidelines	14
Baking	14
Taping Specifications (in Accordance with JIS C 0806)	15
Customer Feedback Form	17
Customer Information	17
Product Information	17
Return Information	17
Problem Description or Suggestion	17



List of Figures

Figure 1.	IrMC Transceiver Block Diagram	2
Figure 2.	ZHX1200 Application Block Diagrams	3
Figure 3.	Truth Table	8
Figure 4.	Transmitter Current Versus LED Voltage (Ta=25 °C)	8
Figure 5.	Transmitter Current Versus Supply Voltage (Ta=25 °C)	9
Figure 6.	Radiant Intensity Versus Transmitter Current (Ta=25 °C)	9
Figure 7.	Receive Current Versus Supply Voltage (Ta=25 °C)	10
Figure 8.	LED Relative Radiant Power Versus Wavelength (Ta=25 °C)	10
Figure 9.	Photodiode Relative Radiant Sensitivity Versus Wavelength (Ta=25 °C)	11
Figure 10.	Relative Forward Voltage Versus Ambient (If=35 mA)	11
Figure 11.	ZHX1200 Mechanical Specifications	12
Figure 12.	Temperature Profile for the Top Surface	13
Figure 13.	IrMC Transceiver Packaging	14
Figure 14.	Reel Dimensions	15
Figure 15.	Tape Dimensions and Configuration	16

List of Tables

Table 1.	IrMC Transceiver Pin Out	4
Table 2.	Absolute Maximum Ratings	5
Table 3.	Recommended Operating Conditions	6
Table 4.	Electrical Characteristics	6
Table 5.	Truth Table	7



Description

The ZiLOG ZHX1200 is the transceiver of choice for mobile communication applications in today's ultra compact, power-conscious, portable products, such as mobile phones, pagers, or personal data assistants (PDAs). Specifically designed to support Infrared Data Association (IrDA) IrMC low-power SIR (serial infrared) mode, the transceiver combines an infrared emitting diode (IRED) emitter, a PIN photodiode detector, a digital AC-coupled LED driver, and a receiver/decoder in a single, miniature package.

The ZiLOG ZHX1200 provides an efficient implementation of the low-power SIR standard in a small footprint format. Application circuit space is also minimized, as only one capacitor is required to complete the solution.

Features

- Compliant to the IrDA Specification Low-Power SIR
- Low supply voltage range, 2.7 to 3.6 V
- 0.2 μ A (maximum) shutdown
- Low power, 95 μ A (typical) at 3.3 V
- Ultra small form factor (6.8 mm long x 2.8 mm wide x 2.2 mm high)
- External component: one capacitor
- Extended operating temperature range (-30 °C to $+85$ °C)
- $I_{LED}=35$ mA at 3.6 mW/sr
- Meets IEC 825-1 Class 1 Eye Safety Specifications

Block Diagram

Figure 1 is the block diagram for the IrMC Transceiver.

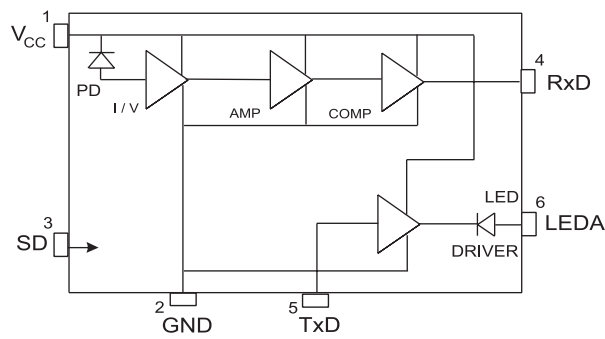

Figure 1. IrMC Transceiver Block Diagram

Figure 2 shows a typical application of the IrMC transceiver.

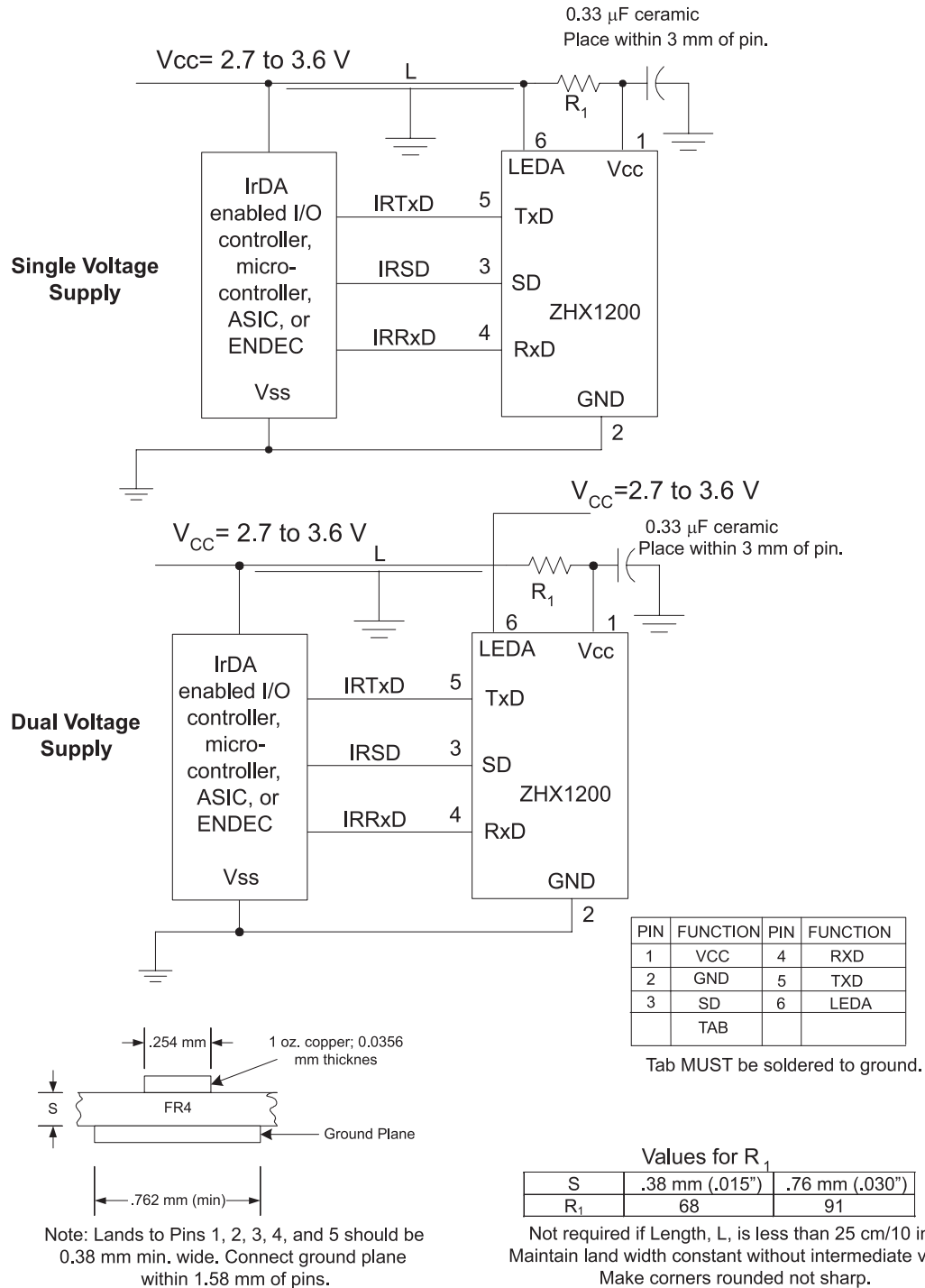

Figure 2. ZHX1200 Application Block Diagrams

Pin Description

Table 1 lists the pin out for the IrMC transceiver. The pins are described in this section.

Table 1. IrMC Transceiver Pin Out

Pin	Name	Function	I/O
1	V _{CC}	Supply voltage	—
2	GND	Ground	—
3	SD	Enables SD mode	I
4	RXD	Receiver output	O
5	TXD	Transmitter input	I
6	LEDA	IRED anode	—
—	TAB	Shield ground	—

V_{CC} Positive Supply

(Power)

Connect to positive power supply (2.7–3.6 V).

Place a 0.33- μ F ceramic bypass capacitor as close as possible to the V_{CC} pin.

GND Ground

(Power)

Connect to ground of the power supply. A solid ground plane is recommended for proper operation.

TAB

(Shield)

The Shield tab must be soldered to the ground plane.

TXD Transmit Data

(Input, active high)

This CMOS input is used to transmit serial data.

TXD has integrated digital AC coupling; therefore, no external AC-coupling components are required for input signals between GND and V_{CC} . This pin can never float while the device is under power.

RXD Receive Data

(Output, active low)

This output indicates received serial data. It is a CMOS output driver capable of driving a standard CMOS or LSTTL load. No external resistor is required.

SD Shutdown

(Input, active high)

This input is used to place the integrated circuit into shutdown mode. Maximum current draw in shutdown mode is 0.2 μ A. Module shutdown current might be limited by the choice of capacitor used from V_{CC1} to ground.

LEDA IRED Driver Anode

(Power)

This output is internally connected to the LED anode and is connected to the supply voltage. Current to the LED must be limited to a maximum of 50 mA (20% duty cycle maximum). The voltage range on this pad is 2.7–3.6 volts.

Electrical and Timing Specifications

Table 2, Table 3, and Table 4 list the electrical and timing specifications.

Table 2. Absolute Maximum Ratings

Parameter	Symbol	Min	Max	Unit	Comment
Supply voltage	V_{CC}	0	7.0	V	V_{CC} , GND
Input voltage	V_{IN}	GND–0.3	$V_{CC}+0.3$	V	TxD, SD
Output (Ext.) voltage	V_{OUT}	GND–0.3	$V_{CC}+0.3$	V	RxD
LED current	I_{LED}		50	mA	20% duty cycle, $T_a=25\text{ }^\circ\text{C}$, $t_{ON}\leq 90\text{ }\mu\text{S}$
Storage temperature	T_{ST}	–40	100	$^\circ\text{C}$	
Solder temperature	T_{SOL}		260	$^\circ\text{C}$	

Table 3. Recommended Operating Conditions

Parameter	Symbol	Min	Max	Unit
Supply voltage	V_{CC}	2.7	3.6	V
Ambient operating temperature	T_{OP}	-30	85	°C

Table 4. Electrical Characteristics

Parameter	Symbol	Condition	Min	Typical	Max	Unit	Remarks
High-level input voltage	V_{IH}		$0.75V_{CC}$			V	TxD, SD
Low-level input voltage	V_{IL}				0.4	V	TxD, SD
High-level output voltage	V_{OH}	$I_{OH}=20\ \mu A$	$V_{CC}-0.3$			V	RxD
Low-level output voltage	V_{OL}	$I_{OL}=400\ \mu A$			0.3	V	RxD
Transmitter current I_{LED}				35		mA	
Receive current	I_S	$V_{CC}=3.3\ V$		95	120	μA	SD=0 V, TxD=0 V
Standby current	I_{STB}				0.2	μA	SD= V_{CC} , TxD=0 V
Optical rise/fall time	$t_{Rr}t_{Rf}$			40	200	nS	
RxD pulse width	T_{PWA}	SIR=115 Kbps	1.0	1.6	2.0	μS	
Shutdown time ⁽¹⁾	T_{SD}				1	μS	
Startup time ⁽²⁾	T_{STU}				100	μS	
Latency ⁽³⁾	T_{RRT}				60	μS	
Trans. radiant. intensity ⁽⁴⁾	I_E	$I_{LED}=35\ mA$	3.6		28	mW/sr	θ_h , $\theta_v \leq (\pm 15^\circ)$
Minimum threshold irradiance ⁽⁵⁾	E_{emin}	$V_{CC}=3.3\ V$			8.1	$\mu W/cm^2$	θ_h , $\theta_v \leq (\pm 15^\circ)$
Maximum input irradiance	E_{emax}	$V_{CC}=3.3\ V$	500			mW/cm^2	θ_h , $\theta_v \leq (\pm 15^\circ)$



Table 4. Electrical Characteristics (Continued)

Parameter	Symbol	Condition	Min	Typical	Max	Unit	Remarks
Angle of half intensity	θ			20		°	Hor. and vert.
Light pulse rise, fall time	$t_{or}t_{of}$				200	nS	
Optical pulse width ⁽⁶⁾	t_{OPW}			20		μS	TxD="H"
Optical overshoot	t_{OPO}				25	%	
Peak wavelength	λ_p			870		nm	

Unless otherwise noted: $V_{CC}=3.3$ V, $GND=0$ V, $TA=+25$ °C

- (1) The time to go into standby mode after SD is high
- (2) The time to revert to active mode after SD is low
- (3) Time required to shift from transmit to receive
- (4) θ_h is the horizontal angle; θ_v is the vertical angle.
- (5) Noise dependent
- (6) Time LED stays on when TxD is left high

Table 5 and Figure 3 show the truth table for the IrMC transceiver.

Table 5. Truth Table

Input			Output	
SD	TxD	Ee	Ir(LED)	RxD
V_{IL}	V_{IH}	X	High(On)	NV
V_{IL}	V_{IL}	Ee_{IH}	Low(Off)	Low
V_{IH}	V_{IH}	X	Low(Off)	High
V_{IH}	V_{IL}	X	Low(Off)	High

X: Don't care

NV: Not valid

Ee: Input irradiance present at detector surface

$Ee_{IH}: 8.1 \mu W/cm^2 \leq Ee \leq 500 mW/cm^2$

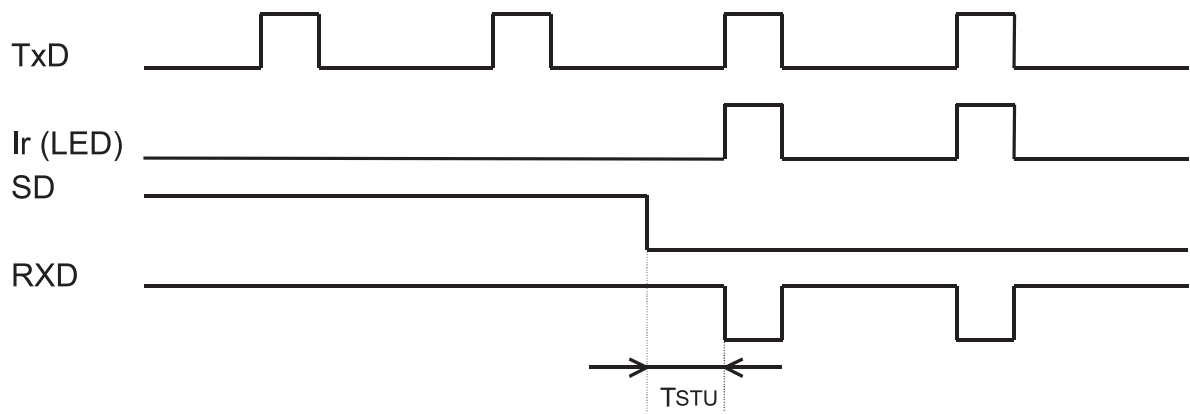

Figure 3. Truth Table

Transceiver Performance

Figure 4 through Figure 10 show the performance of the IrMC transceiver.

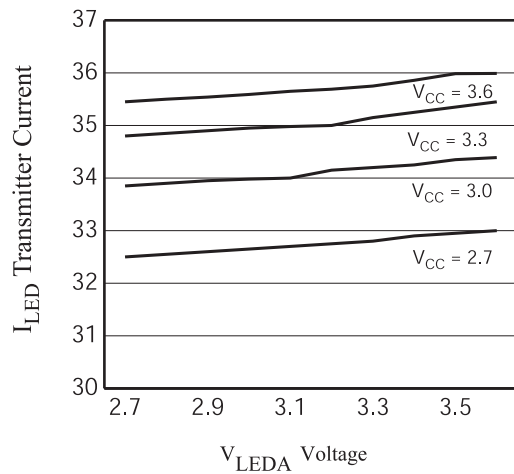

Figure 4. Transmitter Current Versus LED Voltage (Ta=25 °C)

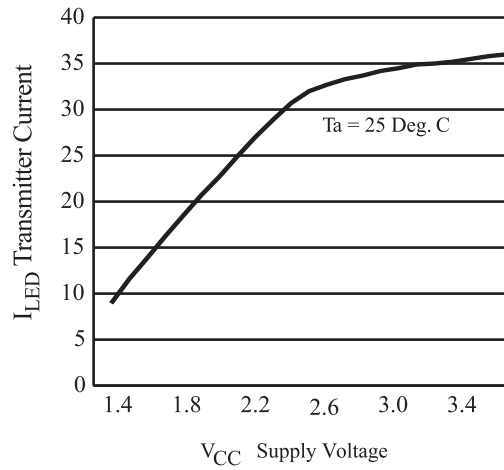

Figure 5. Transmitter Current Versus Supply Voltage (Ta=25 °C)

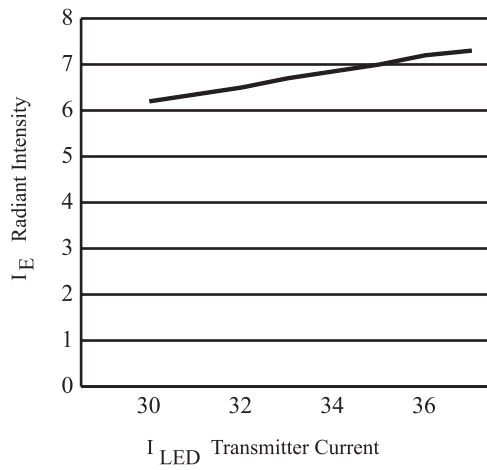

Figure 6. Radiant Intensity Versus Transmitter Current (Ta=25 °C)

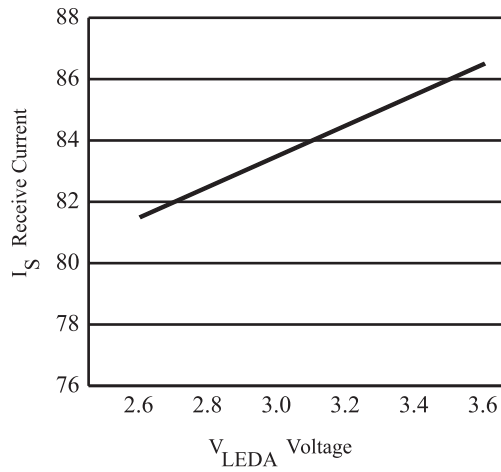

Figure 7. Receive Current Versus Supply Voltage ($T_a=25\text{ }^\circ\text{C}$)

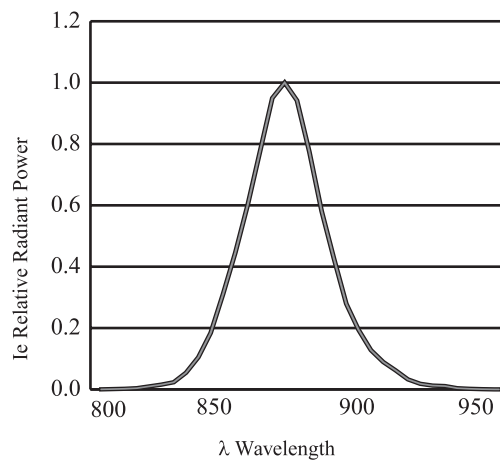

Figure 8. LED Relative Radiant Power Versus Wavelength ($T_a=25\text{ }^\circ\text{C}$)

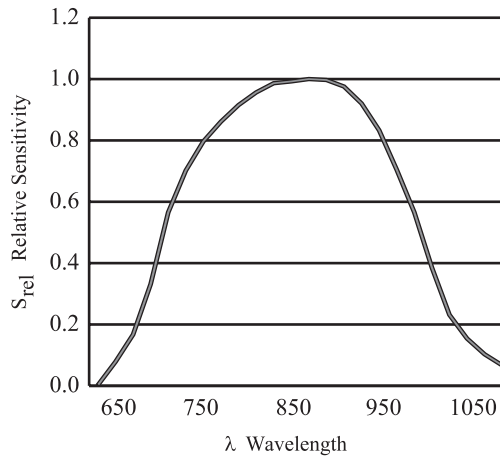

Figure 9. Photodiode Relative Radiant Sensitivity Versus Wavelength (Ta=25 °C)

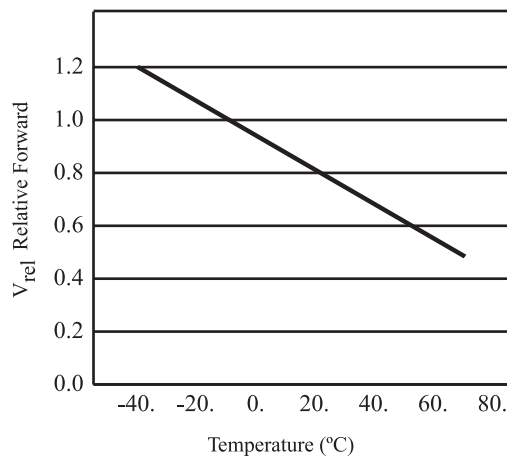

Figure 10. Relative Forward Voltage Versus Ambient (I_F=35 mA)

Mechanical Specifications

Figure 11 shows the mechanical specifications for the IrMC transceiver. Please see the ZHX1200 Solderability Hints application note for solder suggestions.



Note: The ZiLOG ZHX1200 transceiver will continue to show the original Calibre part number, CHX1200.

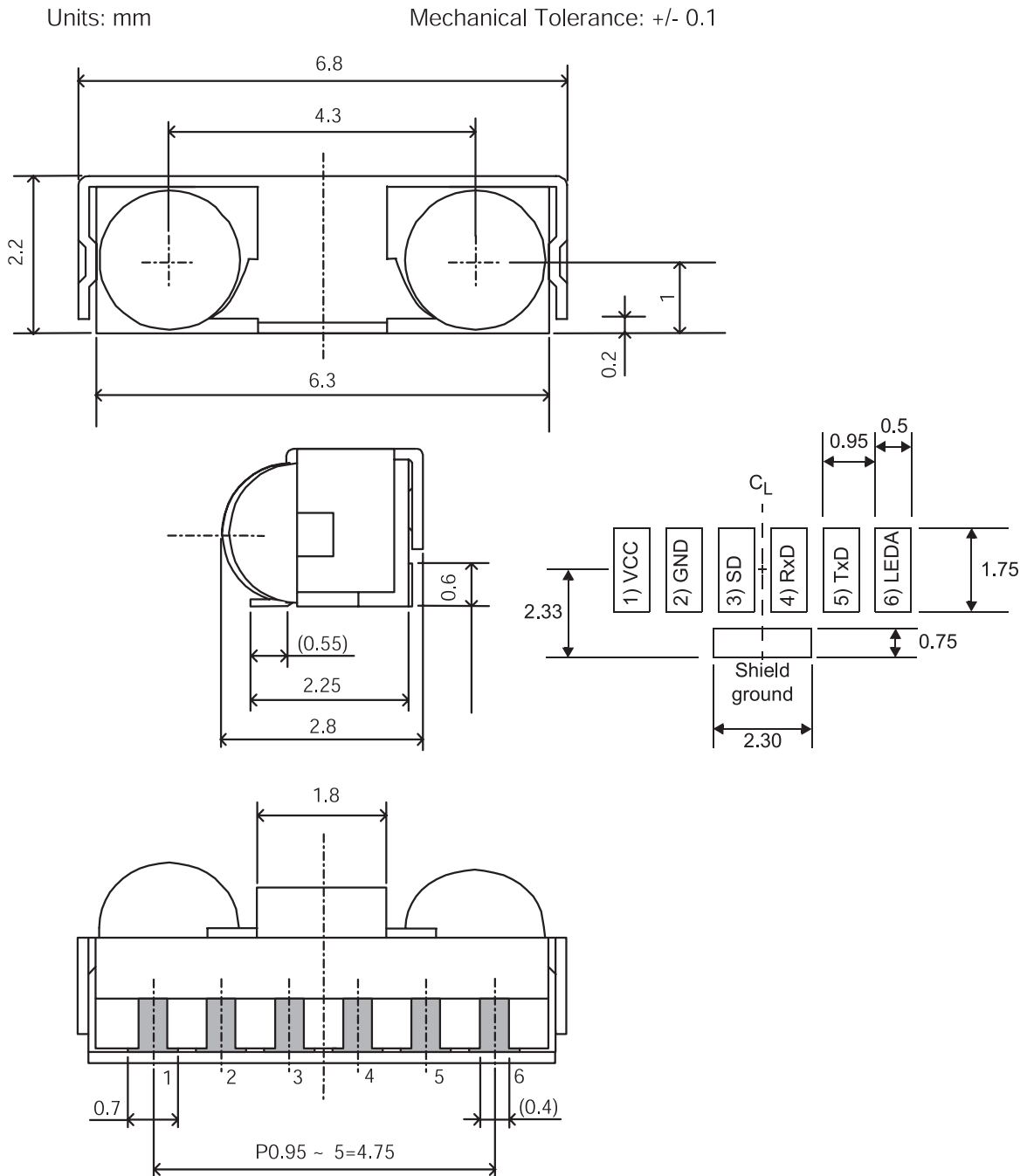

Figure 11. ZHX1200 Mechanical Specifications

Recommended Soldering Conditions

Follow these recommendations to maintain the performance of the ZHX1200 transceiver.

- With the soldering iron:
Temperature at tip: no more than 280 °C
Time: 3 seconds *maximum*
- Reflow:
Preheat: 120 °C to 150 °C, 60 to 120 seconds
Soldering: 230 °C, within 10 seconds
Heating up and cooling down: 5 °C/second
Number of soldering times: 2 times *maximum*
- The temperature profile at the top surface of ZHX1200, shown in Figure 12, is recommended.

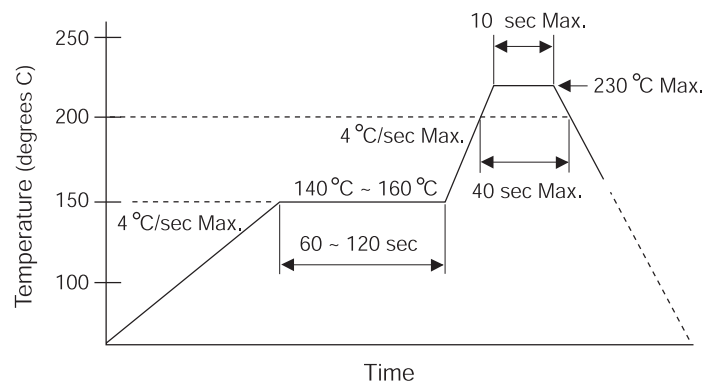

Figure 12. Temperature Profile for the Top Surface

► **Note:** Please see the ZHX1200 Solderability Hints application note for additional information:

<http://www.zilog.com/docs/irda/appnotes/an0107.pdf>

Packing, Storing, and Baking Recommendations

Follow these recommendations to maintain the performance of the ZHX1200 transceiver.

Moisture Prevention Guidelines

In order to avoid moisture absorption during transportation and storage, ZHX1200 reels are packed in aluminum envelopes (see Figure 13) that contain a desiccant with a humidity indicator. While this packaging is an impediment to moisture absorption, it is by no means absolute, and no warranty is implied. The user should store these parts in a controlled environment to prevent moisture entry. Please read the label on the aluminum bag for indicator instructions.

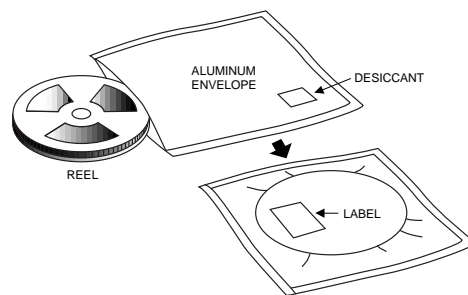

Figure 13. IrMC Transceiver Packaging

Baking

Parts that have been stored over 12 months or unpacked over 72 hours must be baked under the following guidelines.

Reels

60 °C for 48 hours or more

Loose Parts

- 100 °C for 4 hours or more
or
- 125 °C for 2 hours or more
or
- 150 °C for 1 hour or more

Taping Specifications (in Accordance with JIS C 0806)

Figure 14 shows the reel dimensions, and Figure 15 shows the tape dimensions and configuration.

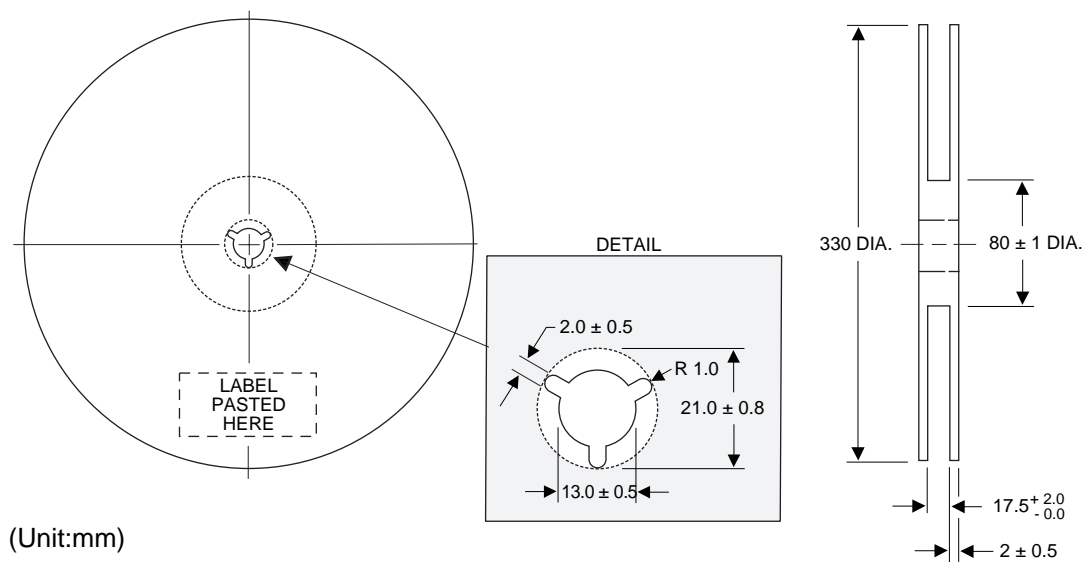

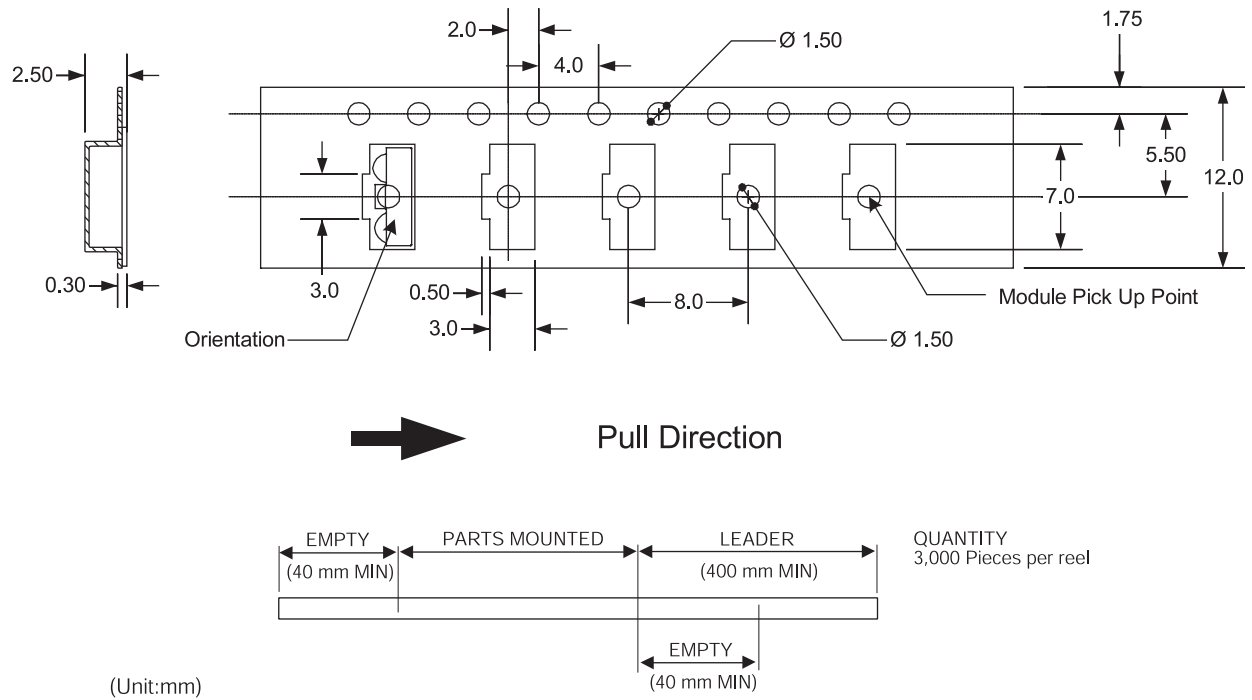

Figure 15. Tape Dimensions and Configuration



Customer Feedback Form

If you experience any problems while operating this product, or if you note any inaccuracies while reading this product specification, please copy and complete this form, then mail or fax it to ZiLOG (see *Return Information*, below). We also welcome your suggestions!

Customer Information

Name	Country
Company	Phone
Address	Fax
City/State/Zip	email

Product Information

Serial # or Board Fab #/Rev #
Software Version
Document Number
Host Computer Description/Type

Return Information

ZiLOG
System Test/Customer Support
532 Race Street
San Jose, CA 95126-3432
Fax: (408) 558-8300
Email: tools@zilog.com

Problem Description or Suggestion

Provide a complete description of the problem or your suggestion. If you are reporting a specific problem, include all steps leading up to the occurrence of the problem. Attach additional pages as necessary.
