



74AC257

QUAD 2 CHANNEL MULTIPLEXER (3-STATE)

- HIGH SPEED: $t_{PD} = 4.5 \text{ ns}$ (TYP.) at $V_{CC} = 5V$
- LOW POWER DISSIPATION:
 $I_{CC} = 8 \mu A$ (MAX.) at $T_A = 25^\circ C$
- HIGH NOISE IMMUNITY:
 $V_{NIH} = V_{NIL} = 28\% V_{CC}$ (MIN.)
- 50Ω TRANSMISSION LINE DRIVING CAPABILITY
- SYMMETRICAL OUTPUT IMPEDANCE:
 $|I_{OH}| = I_{OL} = 24 \text{ mA}$ (MIN)
- BALANCED PROPAGATION DELAYS:
 $t_{PLH} \cong t_{PHL}$
- OPERATING VOLTAGE RANGE:
 V_{CC} (OPR) = 2V to 6V
- PIN AND FUNCTION COMPATIBLE WITH 74 SERIES 257
- IMPROVED LATCH-UP IMMUNITY

DESCRIPTION

The AC257 is an advanced high-speed CMOS QUAD 2 CHANNEL MULTIPLEXER (3-STATE) fabricated with sub-micron silicon gate and double-layer metal wiring C²MOS technology.

It is ideal for low power applications maintaining high speed operation similar to equivalent Bipolar Schottky TTL.

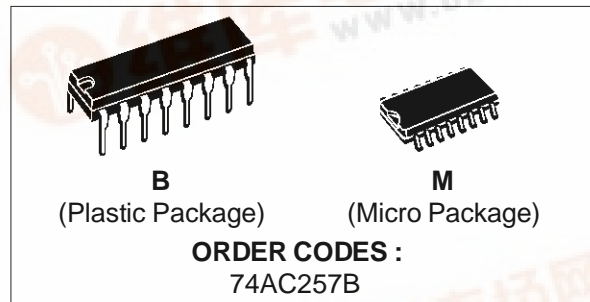

These IC's are composed of an independent 2 channel multiplexer with common SELECT and ENABLE INPUT.

The AC257 is a non inverting multiplexer.

When the ENABLE INPUT is held "High", outputs of both IC's become high impedance state. If SELECT INPUT is held "Low", "A" data is selected, when SELECT INPUT is "High", "B" data is chosen.

All inputs and outputs are equipped with protection circuits against static discharge, giving them 2KV ESD immunity and transient excess voltage.

PIN CONNECTION AND IEC LOGIC SYMBOLS

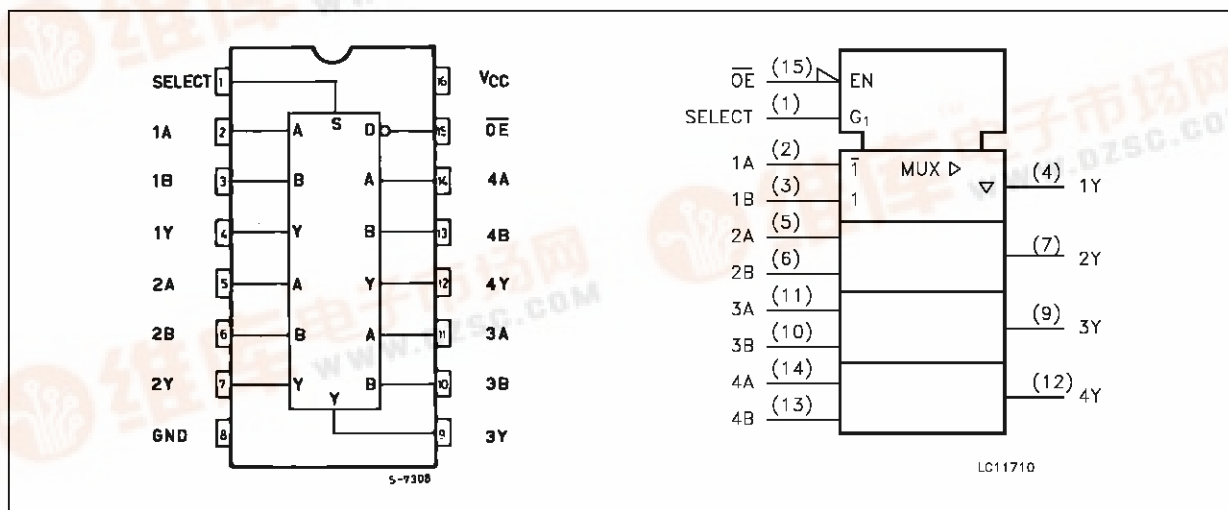

74AC257

INPUT AND OUTPUT EQUIVALENT CIRCUIT

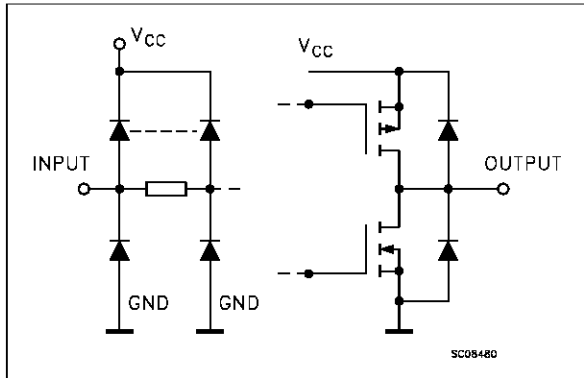

PIN DESCRIPTION

PIN No	SYMBOL	NAME AND FUNCTION
1	SELECT	Common Data Select Input
2, 5, 14, 11	1A to 4A	Data Input From Source A
3, 6, 13, 10	1B to 4B	Data Inputs from Source B
4, 7, 12, 9	1Y to 4Y	3 State Multiplexer Outputs
15	\overline{OE}	3 State Output Enable Inputs (Active LOW)
8	GND	Ground (0V)
16	V _{CC}	Positive Supply Voltage

TRUTH TABLE

\overline{OE}	INPUTS			OUTPUTS
	SELECT	A	B	Y
H	X	X	X	Z
L	L	L	X	L
L	L	H	X	H
L	H	X	L	L
L	H	X	H	H

X = DON'T CARE Z = HIGH IMPEDANCE

LOGIC DIAGRAM

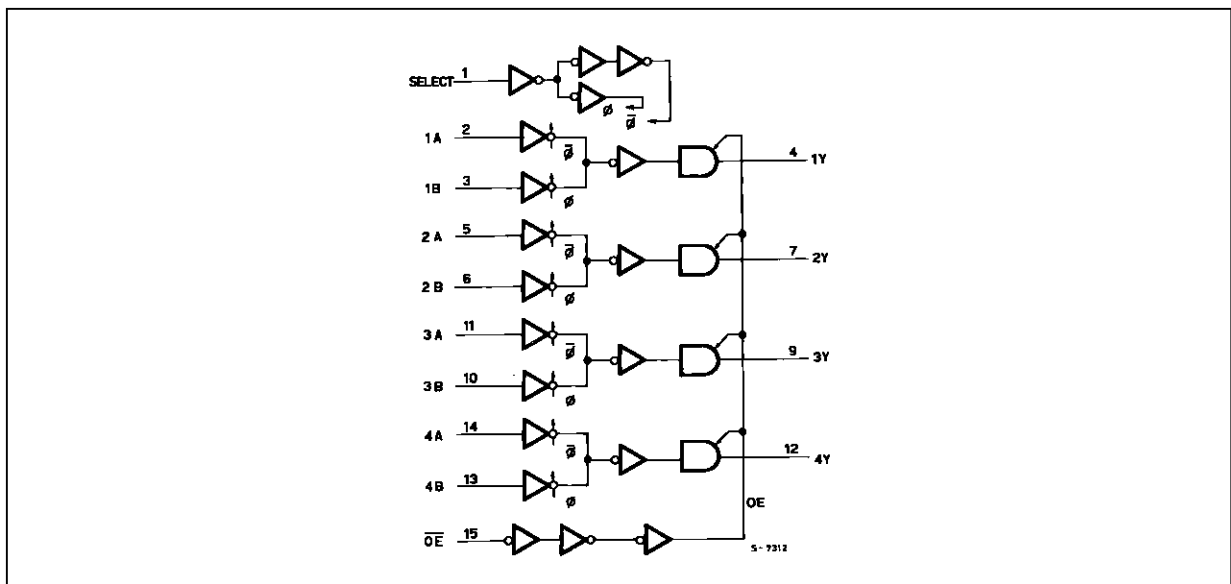

This logic diagram has not been used to estimate propagation delays

ABSOLUTE MAXIMUM RATINGS

Symbol	Parameter	Value	Unit
V_{CC}	Supply Voltage	-0.5 to +7	V
V_I	DC Input Voltage	-0.5 to $V_{CC} + 0.5$	V
V_O	DC Output Voltage	-0.5 to $V_{CC} + 0.5$	V
I_{IK}	DC Input Diode Current	± 20	mA
I_{OK}	DC Output Diode Current	± 20	mA
I_O	DC Output Current	± 50	mA
I_{CC} or I_{GND}	DC V_{CC} or Ground Current	± 200	mA
T_{stg}	Storage Temperature	-65 to +150	$^{\circ}C$
T_L	Lead Temperature (10 sec)	300	$^{\circ}C$

Absolute Maximum Ratings are those values beyond which damage to the device may occur. Functional operation under these condition is not implied.

RECOMMENDED OPERATING CONDITIONS

Symbol	Parameter	Value	Unit
V_{CC}	Supply Voltage	2 to 6	V
V_I	Input Voltage	0 to V_{CC}	V
V_O	Output Voltage	0 to V_{CC}	V
T_{op}	Operating Temperature:	-40 to +85	$^{\circ}C$
dt/dv	Input Rise and Fall Time $V_{CC} = 3.0, 4.5$ or 5.5 V(note 1)	8	ns/V

1) V_{IN} from 30% to 70% of V_{CC}

DC SPECIFICATIONS

Symbol	Parameter	Test Conditions		Value					Unit	
				T _A = 25 °C			-40 to 85 °C			
				V _{CC} (V)	Min.	Typ.	Max.	Min.		Max.
V _{IH}	High Level Input Voltage	3.0	V _O = 0.1 V or V _{CC} - 0.1 V	2.1	1.5		2.1		V	
		4.5		3.15	2.25		3.15			
		5.5		3.85	2.75		3.85			
V _{IL}	Low Level Input Voltage	3.0	V _O = 0.1 V or V _{CC} - 0.1 V		1.5	0.9		0.9	V	
		4.5			2.25	1.35		1.35		
		5.5			2.75	1.65		1.65		
V _{OH}	High Level Output Voltage	3.0	V _I ^(*) = V _{IH} or V _{IL}	I _O = -50 μA	2.9	2.99		2.9	V	
		4.5		I _O = -50 μA	4.4	4.49		4.4		
		5.5		I _O = -50 μA	5.4	5.49		5.4		
		3.0		I _O = -12 mA	2.56			2.46		
		4.5		I _O = -24 mA	3.86			3.76		
		5.5		I _O = -24 mA	4.86			4.76		
V _{OL}	Low Level Output Voltage	3.0	V _I ^(*) = V _{IH} or V _{IL}	I _O = 50 μA		0.002	0.1		0.1	V
		4.5		I _O = 50 μA		0.001	0.1		0.1	
		5.5		I _O = 50 μA		0.001	0.1		0.1	
		3.0		I _O = 12 mA			0.36		0.44	
		4.5		I _O = 24 mA			0.36		0.44	
		5.5		I _O = 24 mA			0.36		0.44	
I _I	Input Leakage Current	5.5	V _I = V _{CC} or GND			±0.1		±1	μA	
I _{OZ}	3 State Output Leakage Current	5.5	V _I = V _{IH} or V _{IL} V _O = V _{CC} or GND			±0.5		±5	μA	
I _{CC}	Quiescent Supply Current	5.5	V _I = V _{CC} or GND			8		80	μA	
I _{OLD}	Dynamic Output Current (note 1, 2)	5.5	V _{OLD} = 1.65 V max					75	mA	
I _{OHD}			V _{OHD} = 3.85 V min					-75	mA	

1) Maximum test duration 2ms, one output loaded at time

2) Incident wave switching is guaranteed on transmission lines with impedances as low as 50 Ω.

(*) All outputs loaded.

AC ELECTRICAL CHARACTERISTICS ($C_L = 50 \text{ pF}$, $R_L = 500 \Omega$, Input $t_r = t_f = 3 \text{ ns}$)

Symbol	Parameter	Test Condition		Value					Unit
				$T_A = 25 \text{ }^\circ\text{C}$			$-40 \text{ to } 85 \text{ }^\circ\text{C}$		
				V_{CC} (V)	Min.	Typ.	Max.	Min.	
t_{PLH} t_{PHL}	Propagation Delay Time A,B to Y	3.3 ^(*) 5.0 ^(**)	1.5 1.5	5.5 4.5	8.5 6	1.5 1.5	9 7	ns	
t_{PLH} t_{PHL}	Propagation Delay Time SEL to Y	3.3 ^(*) 5.0 ^(**)	1.5 1.5	7 5.5	10.5 7.5	1.5 1.5	11.5 8.5	ns	
t_{PZL} t_{PZH}	Output Enable Time	3.3 ^(*) 5.0 ^(**)	1.5 1.5	5.5 4.5	9 7.5	1.5 1.5	10 8.5	ns	
t_{PLZ} t_{PHZ}	Output Disable Time	3.3 ^(*) 5.0 ^(**)	1.5 1.5	7 5.5	10 9	1.5 1.5	11 10	ns	

(*) Voltage range is $3.3\text{V} \pm 0.3\text{V}$ (**) Voltage range is $5\text{V} \pm 0.5\text{V}$ **CAPACITIVE CHARACTERISTICS**

Symbol	Parameter	Test Conditions		Value					Unit
				$T_A = 25 \text{ }^\circ\text{C}$			$-40 \text{ to } 85 \text{ }^\circ\text{C}$		
				V_{CC} (V)	Min.	Typ.	Max.	Min.	
C_{OUT}	Output Capacitance	5.0		8					pF
C_{IN}	Input Capacitance	5.0		4					pF
C_{PD}	Power Dissipation Capacitance (note 1)	5.0		20					pF

1) C_{PD} is defined as the value of the IC's internal equivalent capacitance which is calculated from the operating current consumption without load. (Refer to Test Circuit). Average operating current can be obtained by the following equation. $I_{CC(opr)} = C_{PD} \cdot V_{CC} \cdot f_{IN} + I_{CC}/n$ (per circuit)

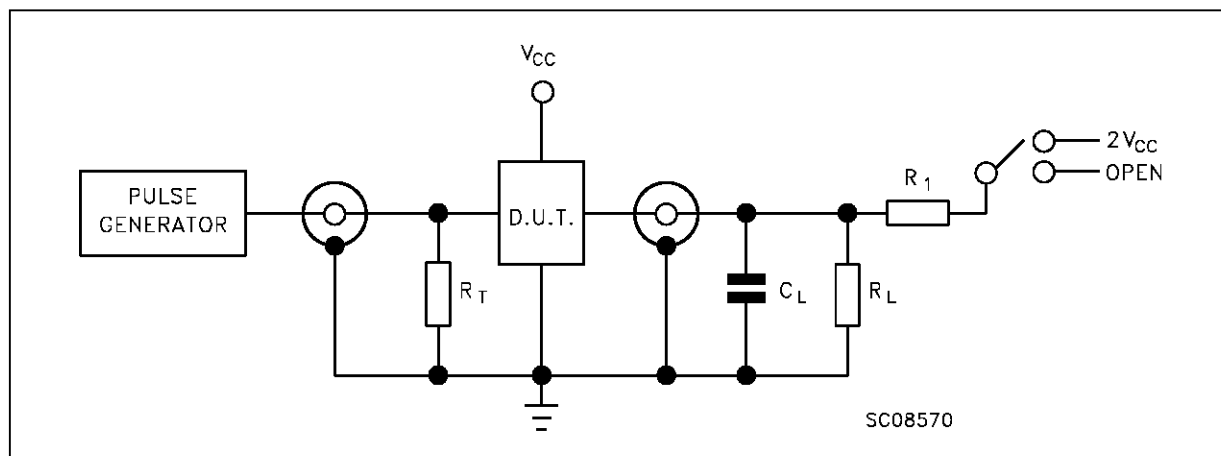
TEST CIRCUIT

TEST	SWITCH
t_{PLH} , t_{PHL}	Open
t_{PZL} , t_{PLZ}	$2V_{CC}$
t_{PZH} , t_{PHZ}	Open

 $C_L = 50 \text{ pF}$ or equivalent (includes jig and probe capacitance) $R_L = R_1 = 500 \Omega$ or equivalent $R_T = Z_{out}$ of pulse generator (typically 50Ω)

WAVEFORM 1: PROPAGATION DELAYS FOR INVERTING CONDITIONS (f=1MHz; 50% duty cycle)

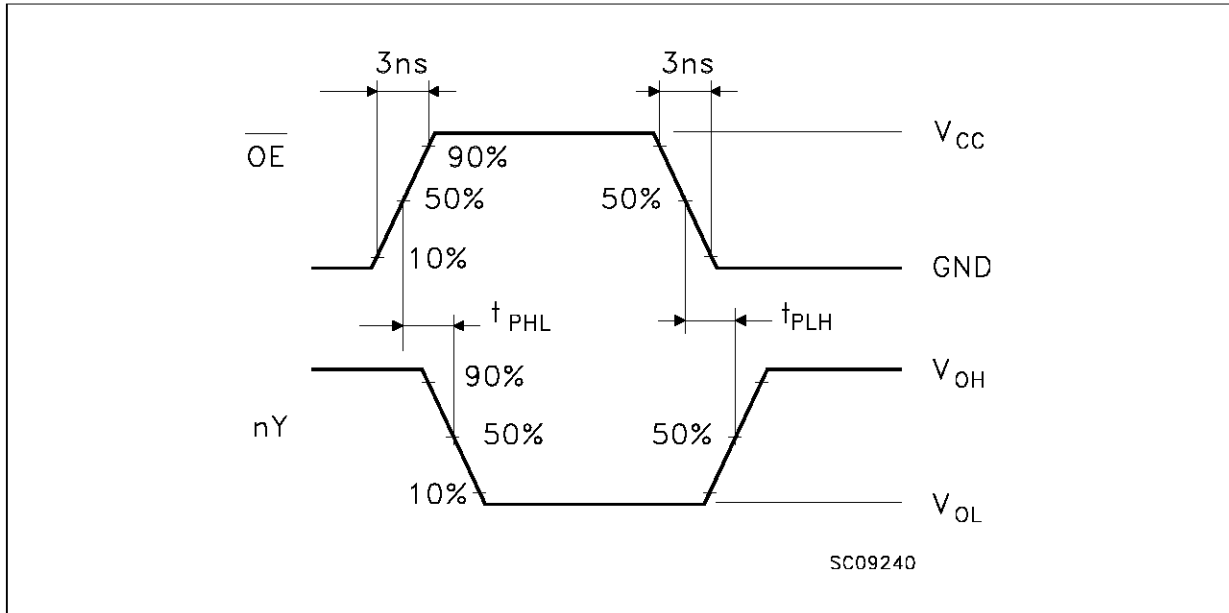

WAVEFORM 2: PROPAGATION DELAYS FOR NON-INVERTING CONDITIONS (f=1MHz; 50% duty cycle)

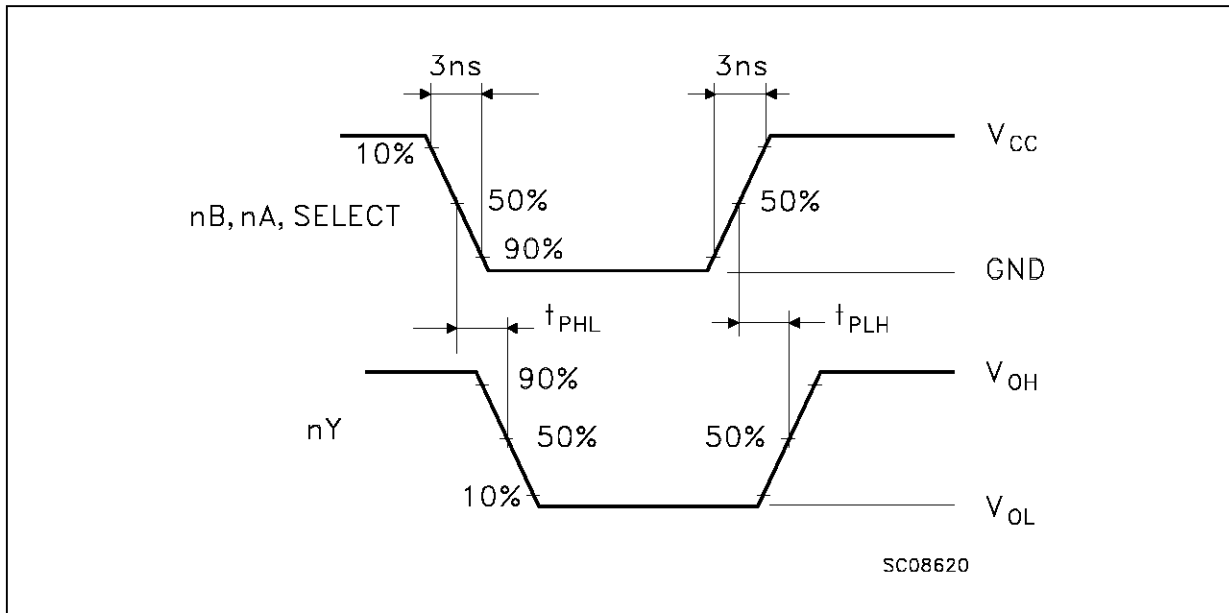

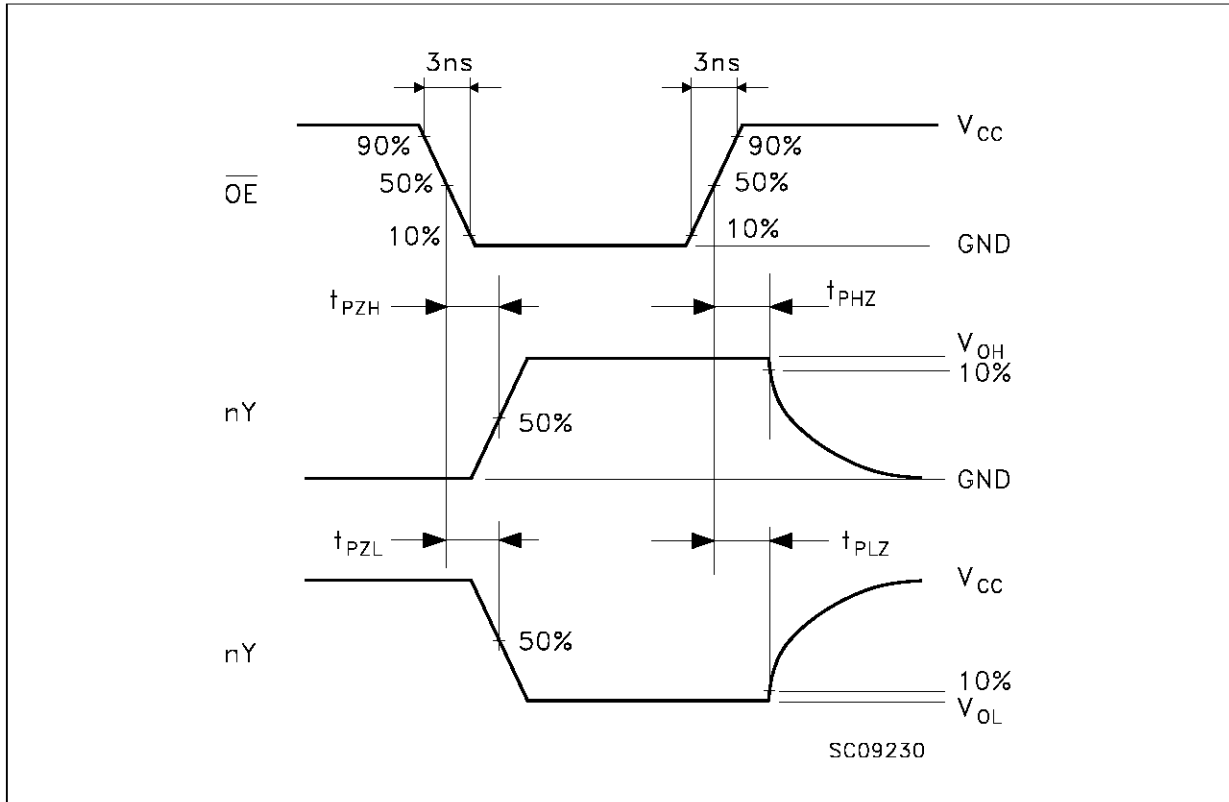
WAVEFORM 3: OUTPUT ENABLE AND DISABLE TIME ($f=1\text{MHz}$; 50% duty cycle)

Plastic DIP16 (0.25) MECHANICAL DATA

DIM.	mm			inch		
	MIN.	TYP.	MAX.	MIN.	TYP.	MAX.
a1	0.51			0.020		
B	0.77		1.65	0.030		0.065
b		0.5			0.020	
b1		0.25			0.010	
D			20			0.787
E		8.5			0.335	
e		2.54			0.100	
e3		17.78			0.700	
F			7.1			0.280
I			5.1			0.201
L		3.3			0.130	
Z			1.27			0.050

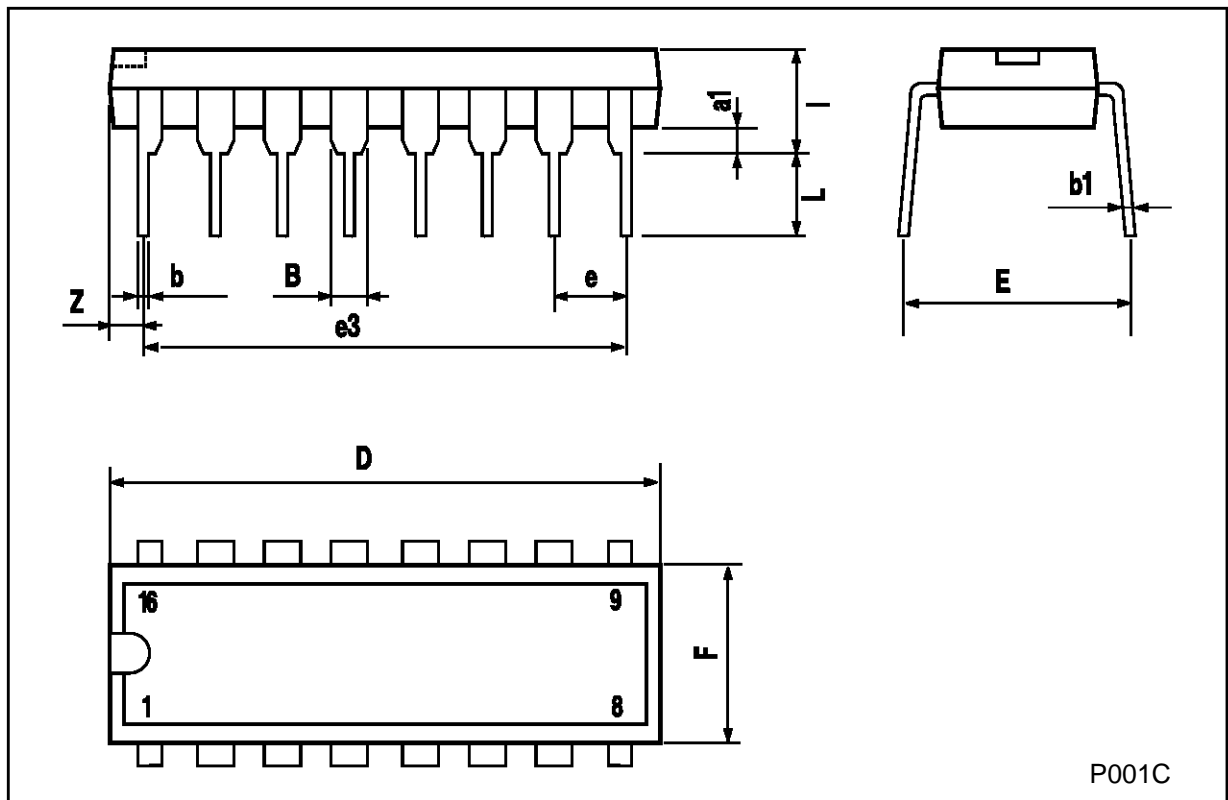

SO16 MECHANICAL DATA

DIM.	mm			inch		
	MIN.	TYP.	MAX.	MIN.	TYP.	MAX.
A			1.75			0.068
a1	0.1		0.2	0.004		0.007
a2			1.65			0.064
b	0.35		0.46	0.013		0.018
b1	0.19		0.25	0.007		0.010
C		0.5			0.019	
c1	45 (typ.)					
D	9.8		10	0.385		0.393
E	5.8		6.2	0.228		0.244
e		1.27			0.050	
e3		8.89			0.350	
F	3.8		4.0	0.149		0.157
G	4.6		5.3	0.181		0.208
L	0.5		1.27	0.019		0.050
M			0.62			0.024
S	8 (max.)					

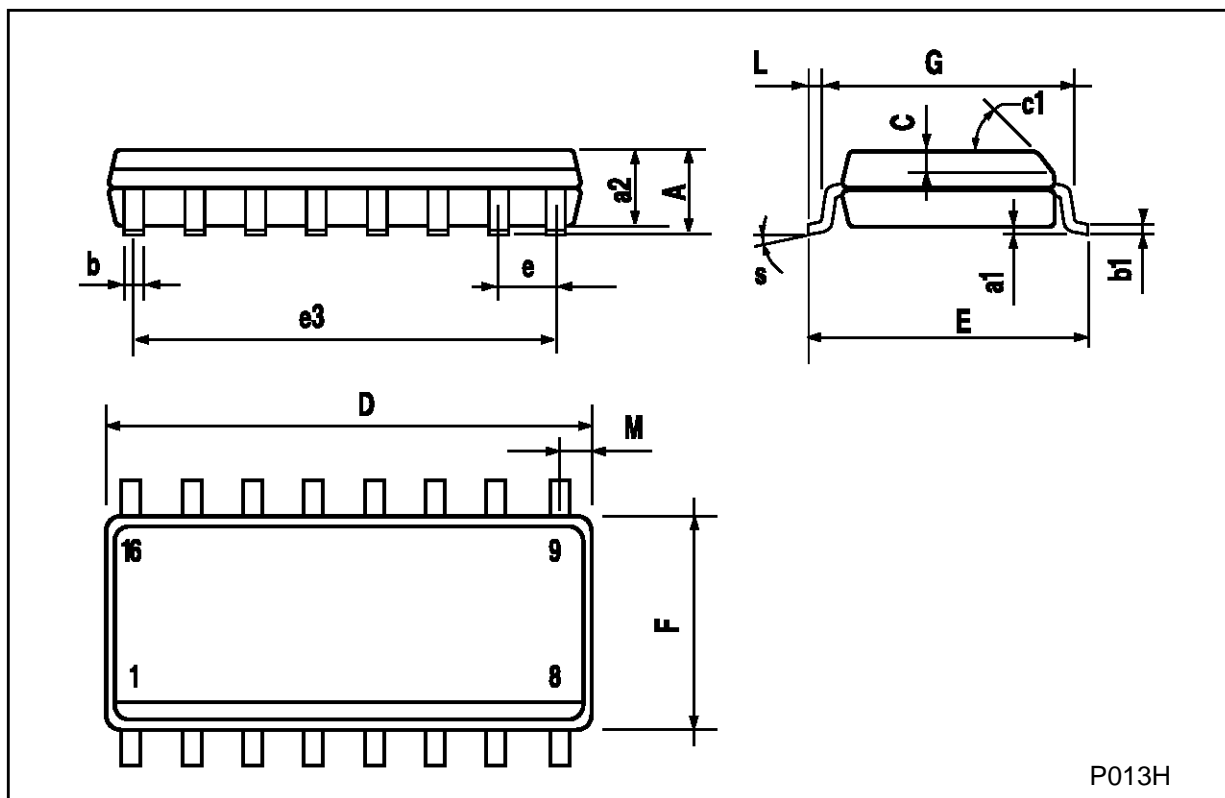

Information furnished is believed to be accurate and reliable. However, SGS-THOMSON Microelectronics assumes no responsibility for the consequences of use of such information nor for any infringement of patents or other rights of third parties which may result from its use. No license is granted by implication or otherwise under any patent or patent rights of SGS-THOMSON Microelectronics. Specifications mentioned in this publication are subject to change without notice. This publication supersedes and replaces all information previously supplied. SGS-THOMSON Microelectronics products are not authorized for use as critical components in life support devices or systems without express written approval of SGS-THOMSON Microelectronics.

© 1997 SGS-THOMSON Microelectronics - Printed in Italy - All Rights Reserved

SGS-THOMSON Microelectronics GROUP OF COMPANIES
Australia - Brazil - Canada - China - France - Germany - Hong Kong - Italy - Japan - Korea - Malaysia - Malta - Morocco - The Netherlands -
Singapore - Spain - Sweden - Switzerland - Taiwan - Thailand - United Kingdom - U.S.A