

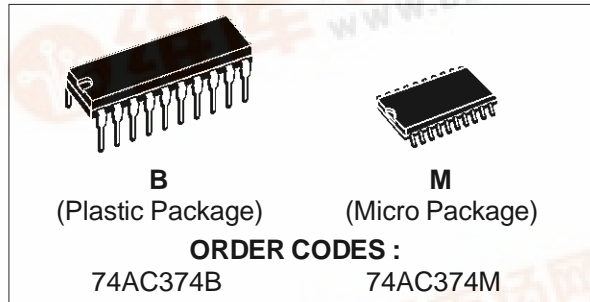

74AC374

OCTAL D-TYPE FLIP FLOP WITH 3 STATE OUTPUT NON INVERTING

- HIGH SPEED:
 - $f_{MAX} = 270$ MHz (TYP.) at $V_{CC} = 5V$
- LOW POWER DISSIPATION:
 - $I_{CC} = 8 \mu A$ (MAX.) at $T_A = 25 \text{ }^\circ C$
- HIGH NOISE IMMUNITY:
 - $V_{NIH} = V_{NIL} = 28\% V_{CC}$ (MIN.)
- 50Ω TRANSMISSION LINE DRIVING CAPABILITY
- SYMMETRICAL OUTPUT IMPEDANCE:
 - $|I_{OH}| = I_{OL} = 24$ mA (MIN)
- BALANCED PROPAGATION DELAYS:
 - $t_{PLH} \cong t_{PHL}$
- OPERATING VOLTAGE RANGE:
 - V_{CC} (OPR) = 2V to 6V
- PIN AND FUNCTION COMPATIBLE WITH 74 SERIES 374
- IMPROVED LATCH-UP IMMUNITY



DESCRIPTION

The AC374 is an advanced high-speed CMOS OCTAL D-TYPE FLIP FLOP with 3 STATE OUTPUT NON INVERTING fabricated with sub-micron silicon gate and double-layer metal wiring C²MOS technology. It is ideal for low power applications maintaining high speed operation similar to equivalent Bipolar Schottky TTL.

These 8 bit D-Type flip-flops are controlled by a

clock input (CK) and an output enable input (\overline{OE}). On the positive transition of the clock, the Q outputs will be set to the logic state that were setup at the D inputs.

While the (\overline{OE}) input is low, the 8 outputs will be in a normal logic state (high or low logic level) and while high level the outputs will be in a high impedance state.

The output control does not affect the internal operation of flip flops; that is, the old data can be retained or the new data can be entered even while the outputs are off.

All inputs and outputs are equipped with protection circuits against static discharge, giving them 2KV ESD immunity and transient excess voltage.

PIN CONNECTION AND IEC LOGIC SYMBOLS

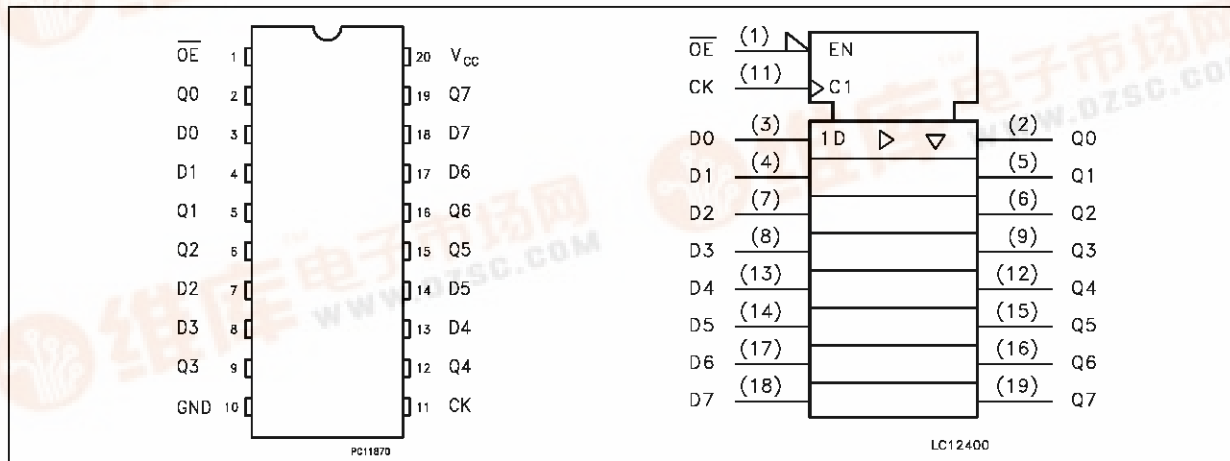

74AC374

INPUT AND OUTPUT EQUIVALENT CIRCUIT

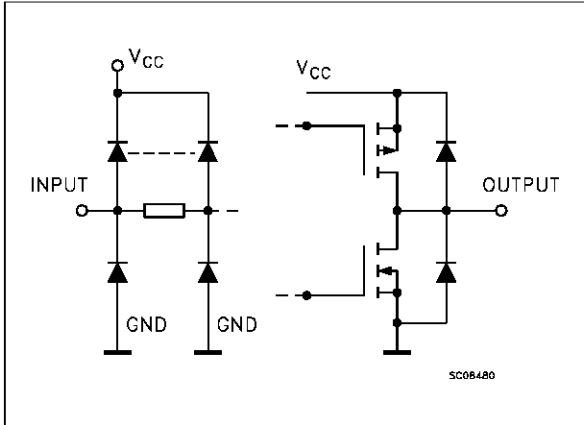

PIN DESCRIPTION

PIN No	SYMBOL	NAME AND FUNCTION
1	\overline{OE}	3 State Output Enable Input (Active LOW)
2, 5, 6, 9, 12, 15, 16, 19	Q0 to Q7	3 State Outputs
3, 4, 7, 8, 13, 14, 17, 18	D0 to D7	Data Inputs
11	CLOCK	Clock Input (LOW to HIGH, edge triggered)
10	GND	Ground (0V)
20	V _{CC}	Positive Supply Voltage

TRUTH TABLE

INPUTS			OUTPUTS
\overline{OE}	CK	D	Q
H	X	X	Z
L		X	NO CHANGE
L		L	L
L		H	H

LOGIC DIAGRAM

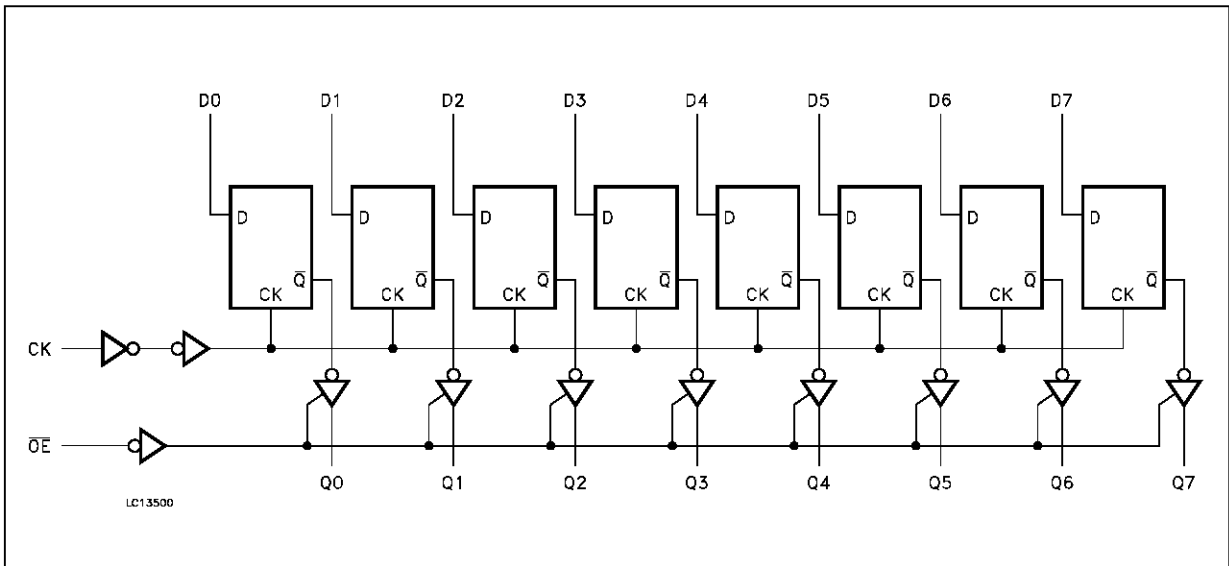

ABSOLUTE MAXIMUM RATINGS

Symbol	Parameter	Value	Unit
V_{CC}	Supply Voltage	-0.5 to +7	V
V_I	DC Input Voltage	-0.5 to $V_{CC} + 0.5$	V
V_O	DC Output Voltage	-0.5 to $V_{CC} + 0.5$	V
I_{IK}	DC Input Diode Current	± 20	mA
I_{OK}	DC Output Diode Current	± 20	mA
I_O	DC Output Current	± 50	mA
I_{CC} or I_{GND}	DC V_{CC} or Ground Current	± 400	mA
T_{stg}	Storage Temperature	-65 to +150	$^{\circ}C$
T_L	Lead Temperature (10 sec)	300	$^{\circ}C$

Absolute Maximum Ratings are those values beyond which damage to the device may occur. Functional operation under these condition is not implied.

RECOMMENDED OPERATING CONDITIONS

Symbol	Parameter	Value	Unit
V_{CC}	Supply Voltage	2 to 6	V
V_I	Input Voltage	0 to V_{CC}	V
V_O	Output Voltage	0 to V_{CC}	V
T_{op}	Operating Temperature:	-40 to +85	$^{\circ}C$
dt/dv	Input Rise and Fall Time $V_{CC} = 3.0, 4.5$ or 5.5 V(note 1)	8	ns/V

1) V_{IN} from 30% to 70% of V_{CC}

DC SPECIFICATIONS

Symbol	Parameter	Test Conditions		Value					Unit	
				T _A = 25 °C			-40 to 85 °C			
				V _{CC} (V)	Min.	Typ.	Max.	Min.		Max.
V _{IH}	High Level Input Voltage	3.0	V _O = 0.1 V or V _{CC} - 0.1 V	2.1	1.5		2.1		V	
		4.5		3.15	2.25		3.15			
		5.5		3.85	2.75		3.85			
V _{IL}	Low Level Input Voltage	3.0	V _O = 0.1 V or V _{CC} - 0.1 V		1.5	0.9		0.9	V	
		4.5			2.25	1.35		1.35		
		5.5			2.75	1.65		1.65		
V _{OH}	High Level Output Voltage	3.0	V _I ^(*) = V _{IH} or V _{IL}	I _O = -50 μA	2.9	2.99		2.9	V	
		4.5		I _O = -50 μA	4.4	4.49		4.4		
		5.5		I _O = -50 μA	5.4	5.49		5.4		
		3.0		I _O = -12 mA	2.56			2.46		
		4.5		I _O = -24 mA	3.86			3.76		
		5.5		I _O = -24 mA	4.86			4.76		
V _{OL}	Low Level Output Voltage	3.0	V _I ^(*) = V _{IH} or V _{IL}	I _O = 50 μA		0.002	0.1		0.1	V
		4.5		I _O = 50 μA		0.001	0.1		0.1	
		5.5		I _O = 50 μA		0.001	0.1		0.1	
		3.0		I _O = 12 mA			0.36		0.44	
		4.5		I _O = 24 mA			0.36		0.44	
		5.5		I _O = 24 mA			0.36		0.44	
I _I	Input Leakage Current	5.5	V _I = V _{CC} or GND			±0.1		±1	μA	
I _{OZ}	3-State Output Off-state Current	5.5	V _I = V _{CC} or GND V _O = V _{CC} or GND V _{I(OE)} = V _{IH}			±0.5		±5	μA	
I _{CC}	Quiescent Supply Current	5.5	V _I = V _{CC} or GND			8		80	μA	
I _{OLD}	Dynamic Output Current (note 1, 2)	5.5	V _{OLD} = 1.65 V max					75	mA	
I _{OHD}			V _{OHD} = 3.85 V min					-75	mA	

1) Maximum test duration 2ms, one output loaded at time

2) Incident wave switching is guaranteed on transmission lines with impedances as low as 50 Ω.

(*) All outputs loaded.

AC ELECTRICAL CHARACTERISTICS ($C_L = 50$ pF, $R_L = 500$ Ω , Input $t_r = t_f = 3$ ns)

Symbol	Parameter	Test Condition		Value					Unit
				T _A = 25 °C			-40 to 85 °C		
				V _{CC} (V)	Min.	Typ.	Max.	Min.	
t _{PLH} t _{PHL}	Propagation Delay Time CK to Q	3.3 ^(*) 5.0 ^(**)		6.5 5	12 9		13 10	ns	
t _{PZL} t _{PZH}	Output Enable Time	3.3 ^(*) 5.0 ^(**)		7.5 5.5	12 9		13 10	ns	
t _{PLZ} t _{PHZ}	Output Disable Time	3.3 ^(*) 5.0 ^(**)		7.5 6	12 9		13 10	ns	
t _w	Clock Pulse Width HIGH or LOW	3.3 ^(*) 5.0 ^(**)		1.5 1.5	5 4		6 5	ns	
t _s	Setup Time Q to CK HIGH or LOW	3.3 ^(*) 5.0 ^(**)		-0.5 -0.5	5 4		5 4	ns	
t _h	Hold Time Q to CK HIGH or LOW	3.3 ^(*) 5.0 ^(**)		0.5 0.5	2 2		3 3	ns	
f _{MAX}	Maximum Clock Frequency	3.3 ^(*) 5.0 ^(**)		60 100	250 270		60 100	MHz	

(*) Voltage range is 3.3V ± 0.3V

(**) Voltage range is 5V ± 0.5V

CAPACITIVE CHARACTERISTICS

Symbol	Parameter	Test Conditions		Value					Unit
				T _A = 25 °C			-40 to 85 °C		
				V _{CC} (V)	Min.	Typ.	Max.	Min.	
C _{OUT}	Output Capacitance	5.0		8				pF	
C _{IN}	Input Capacitance	5.0		4				pF	
C _{PD}	Power Dissipation Capacitance (note 1)	5.0		46				pF	

1) C_{PD} is defined as the value of the IC's internal equivalent capacitance which is calculated from the operating current consumption without load. (Refer to Test Circuit). Average operating current can be obtained by the following equation. $I_{CC(opr)} = C_{PD} \cdot V_{CC} \cdot f_{IN} + I_{CC}/n$ (per circuit)

74AC374

TEST CIRCUIT

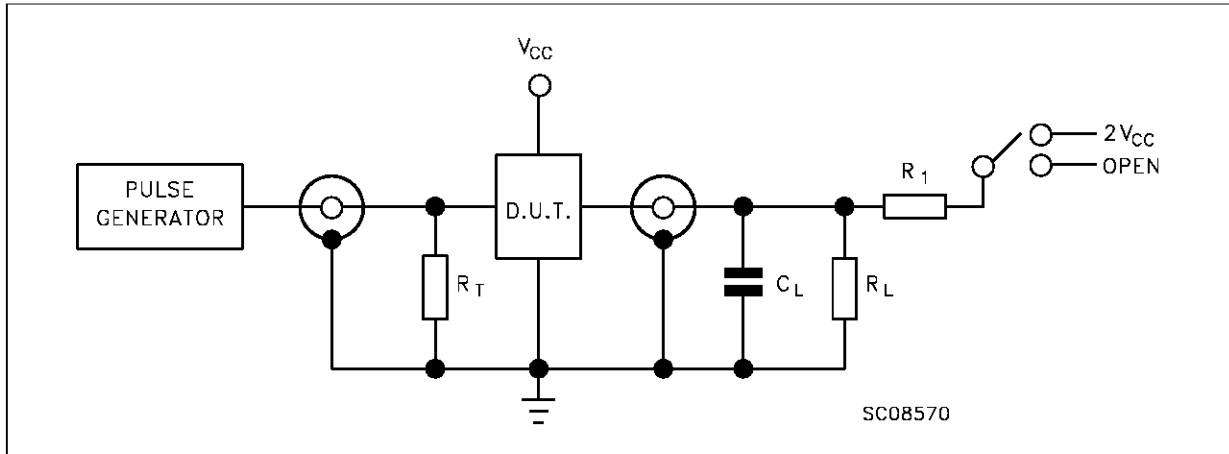

TEST	SWITCH
t_{PLH} , t_{PHL}	Open
t_{PZL} , t_{PLZ}	$2V_{CC}$
t_{PZH} , t_{PHZ}	Open

$C_L = 50$ pF or equivalent (includes jig and probe capacitance)
 $R_L = R_1 = 500\Omega$ or equivalent
 $R_T = Z_{OUT}$ of pulse generator (typically 50Ω)

WAVEFORM 1: PROPAGATION DELAYS, SETUP AND HOLD TIMES ($f=1$ MHz; 50% duty cycle)

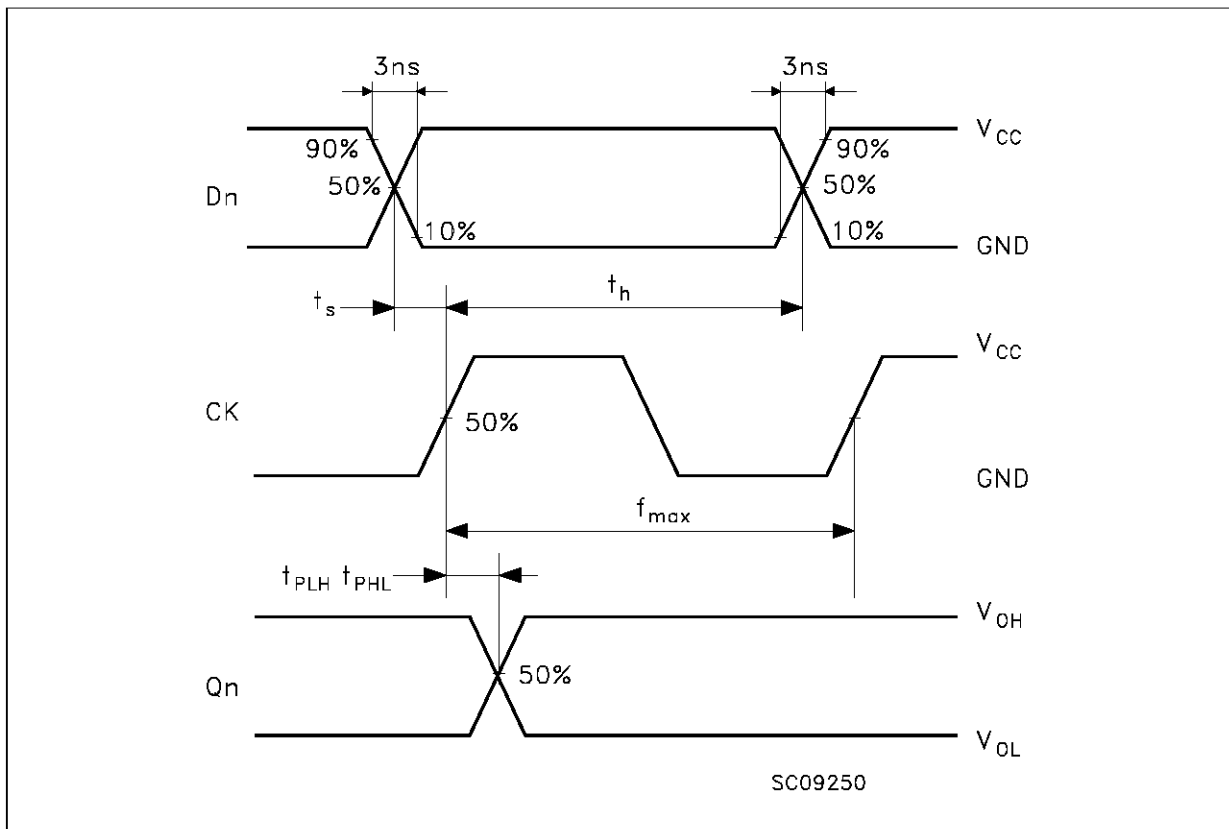

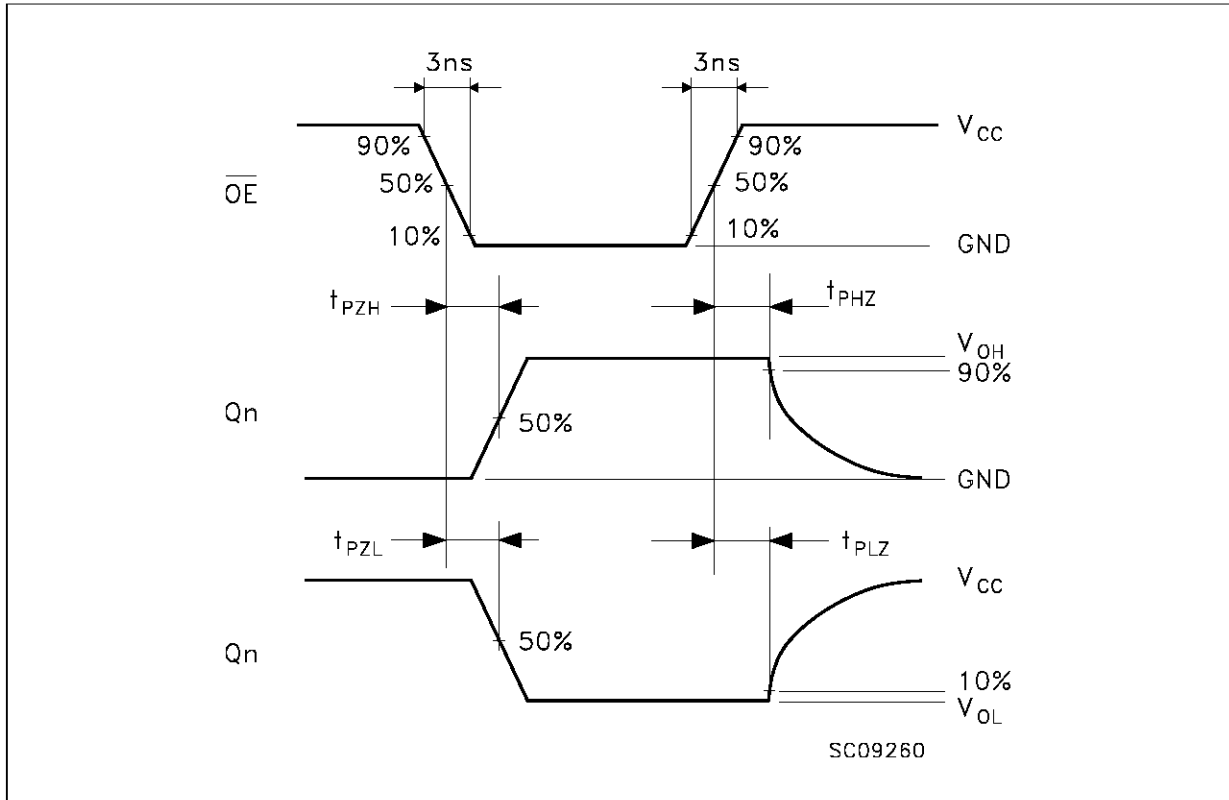
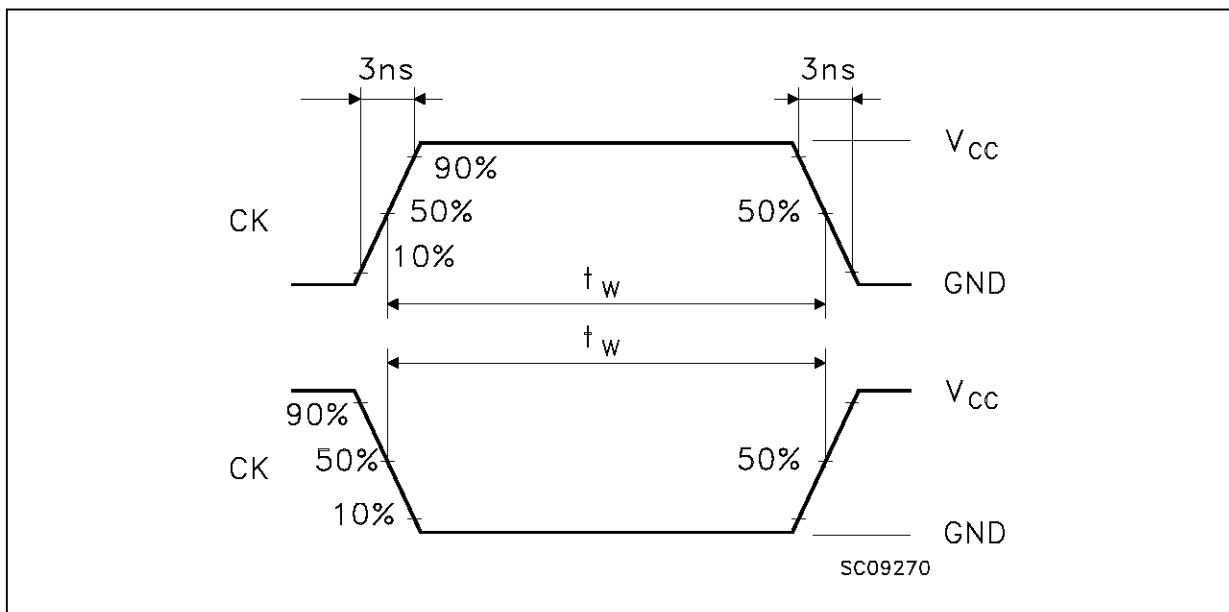
WAVEFORM 2: OUTPUT ENABLE AND DISABLE TIMES ($f=1\text{MHz}$; 50% duty cycle)**WAVEFORM 3: PULSE WIDTH**

Plastic DIP20 (0.25) MECHANICAL DATA

DIM.	mm			inch		
	MIN.	TYP.	MAX.	MIN.	TYP.	MAX.
a1	0.254			0.010		
B	1.39		1.65	0.055		0.065
b		0.45			0.018	
b1		0.25			0.010	
D			25.4			1.000
E		8.5			0.335	
e		2.54			0.100	
e3		22.86			0.900	
F			7.1			0.280
I			3.93			0.155
L		3.3			0.130	
Z			1.34			0.053

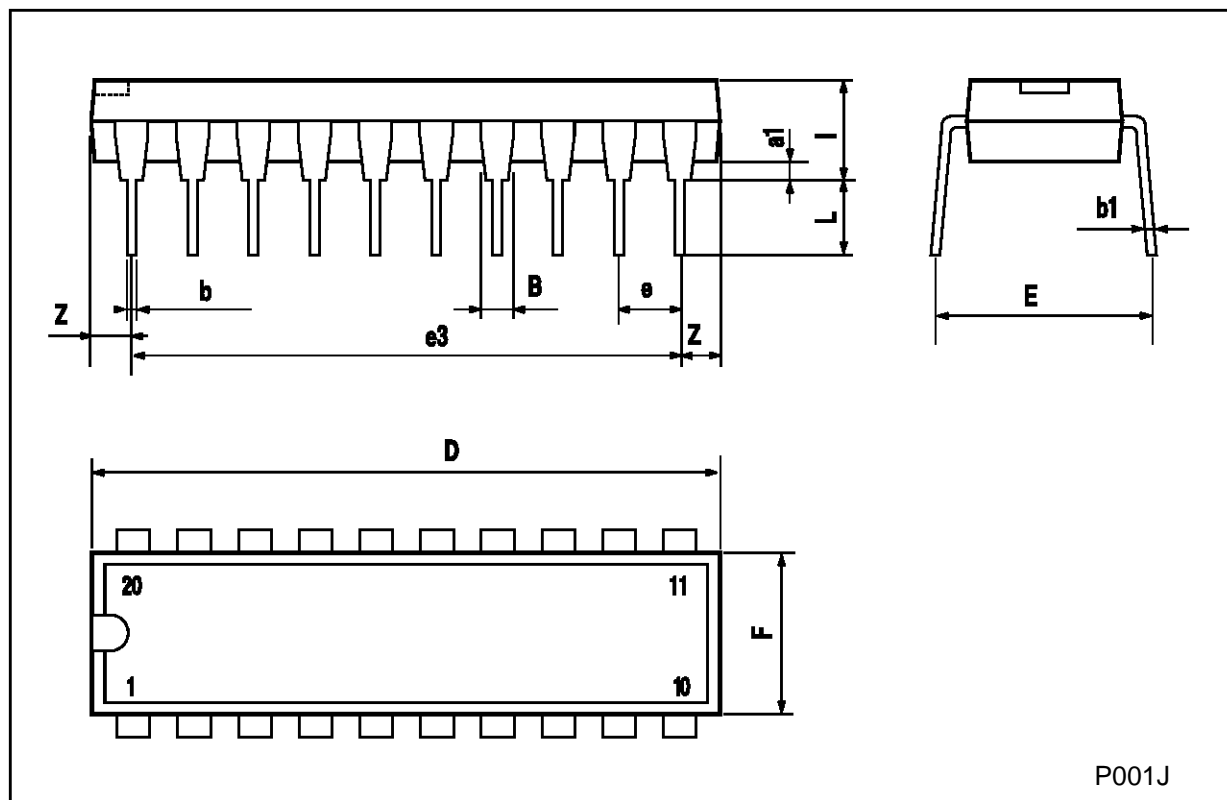

SO20 MECHANICAL DATA

DIM.	mm			inch		
	MIN.	TYP.	MAX.	MIN.	TYP.	MAX.
A			2.65			0.104
a1	0.10		0.20	0.004		0.007
a2			2.45			0.096
b	0.35		0.49	0.013		0.019
b1	0.23		0.32	0.009		0.012
C		0.50			0.020	
c1	45° (typ.)					
D	12.60		13.00	0.496		0.512
E	10.00		10.65	0.393		0.419
e		1.27			0.050	
e3		11.43			0.450	
F	7.40		7.60	0.291		0.299
L	0.50		1.27	0.19		0.050
M			0.75			0.029
S	8° (max.)					

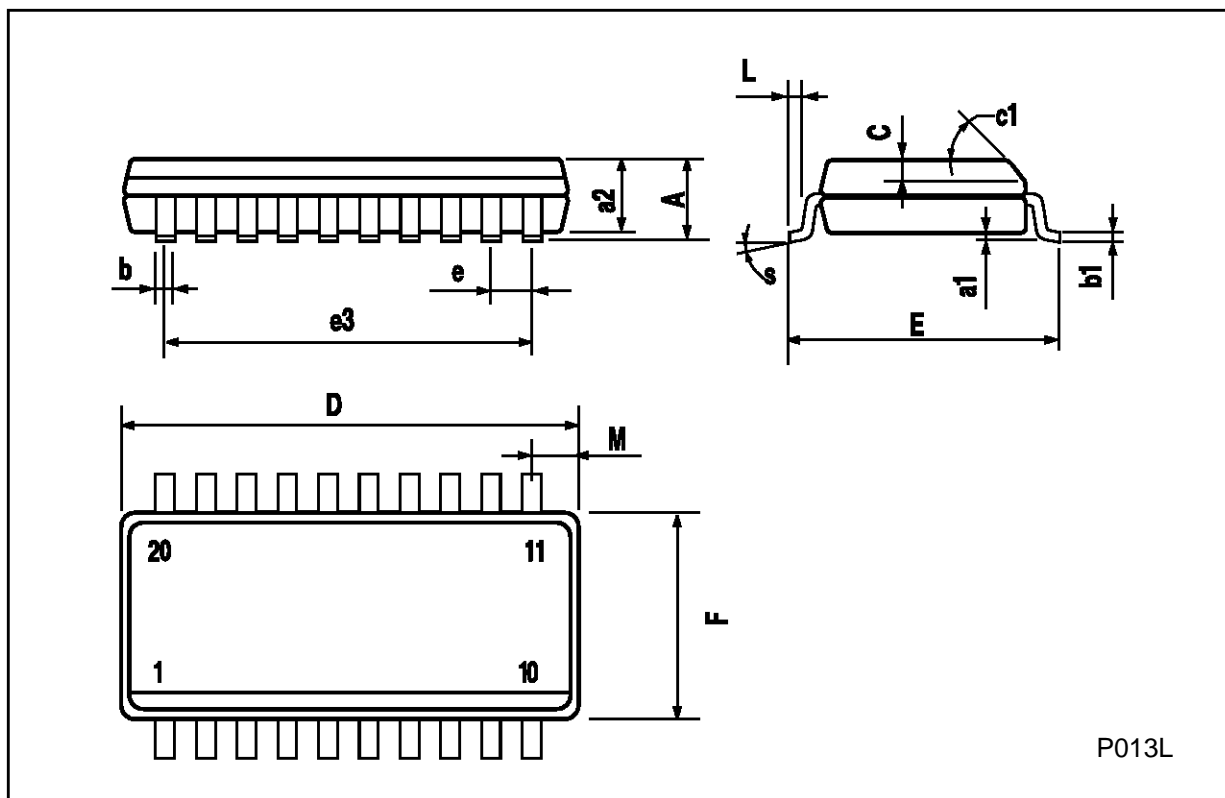

Information furnished is believed to be accurate and reliable. However, SGS-THOMSON Microelectronics assumes no responsibility for the consequences of use of such information nor for any infringement of patents or other rights of third parties which may result from its use. No license is granted by implication or otherwise under any patent or patent rights of SGS-THOMSON Microelectronics. Specifications mentioned in this publication are subject to change without notice. This publication supersedes and replaces all information previously supplied. SGS-THOMSON Microelectronics products are not authorized for use as critical components in life support devices or systems without express written approval of SGS-THOMSON Microelectronics.

© 1997 SGS-THOMSON Microelectronics - Printed in Italy - All Rights Reserved

SGS-THOMSON Microelectronics GROUP OF COMPANIES
Australia - Brazil - Canada - China - France - Germany - Hong Kong - Italy - Japan - Korea - Malaysia - Malta - Morocco - The Netherlands -
Singapore - Spain - Sweden - Switzerland - Taiwan - Thailand - United Kingdom - U.S.A