



# 74VHCT574A

## OCTAL D-TYPE FLIP FLOP WITH 3 STATE OUTPUT NON INVERTING

- HIGH SPEED:  
f<sub>MAX</sub> = 180 MHz (TYP.) at V<sub>CC</sub> = 5V
- LOW POWER DISSIPATION:  
I<sub>CC</sub> = 4 μA (MAX.) at T<sub>A</sub> = 25 °C
- COMPATIBLE WITH TTL OUTPUTS:  
V<sub>IH</sub> = 2V (MIN), V<sub>IL</sub> = 0.8V (MAX)
- POWER DOWN PROTECTION ON INPUTS & OUTPUTS
- SYMMETRICAL OUTPUT IMPEDANCE:  
|I<sub>OH</sub>| = I<sub>OL</sub> = 8 mA (MIN)
- BALANCED PROPAGATION DELAYS:  
t<sub>PLH</sub> ≅ t<sub>PHL</sub>
- OPERATING VOLTAGE RANGE:  
V<sub>CC</sub> (OPR) = 4.5V to 5.5V
- PIN AND FUNCTION COMPATIBLE WITH 74 SERIES 574
- IMPROVED LATCH-UP IMMUNITY
- LOW NOISE V<sub>OLP</sub> = 0.9V (Max.)

### DESCRIPTION

The 74VHCT574A is an advanced high-speed CMOS OCTAL D-TYPE FLIP FLOP with 3 STATE OUTPUT NON INVERTING fabricated with sub-micron silicon gate and double-layer metal wiring C<sup>2</sup>MOS technology.

This 8 bit D-Type flip-flop is controlled by a clock input (CK) and an output enable input (OE).

On the positive transition of the clock, the Q

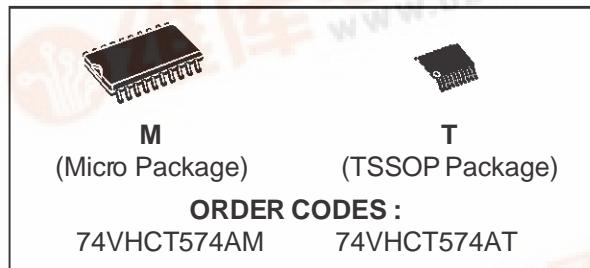

outputs will be set to logic states that were setup at the D inputs.

While the OE input is low, the 8 outputs will be in a normal logic state (high or low logic level) and, while high level, the outputs will be in a high impedance state.

The output control does not affect the internal operation of flip flop; that is, the old data can be retained or the new data can be entered even while the outputs are off.

Power down protection is provided on all inputs and outputs and 0 to 7V can be accepted on inputs with no regard to the supply voltage. This device can be used to interface 5V to 3V.

All inputs and outputs are equipped with protection circuits against static discharge, giving them 2KV ESD immunity and transient excess voltage.

### PIN CONNECTION AND IEC LOGIC SYMBOLS

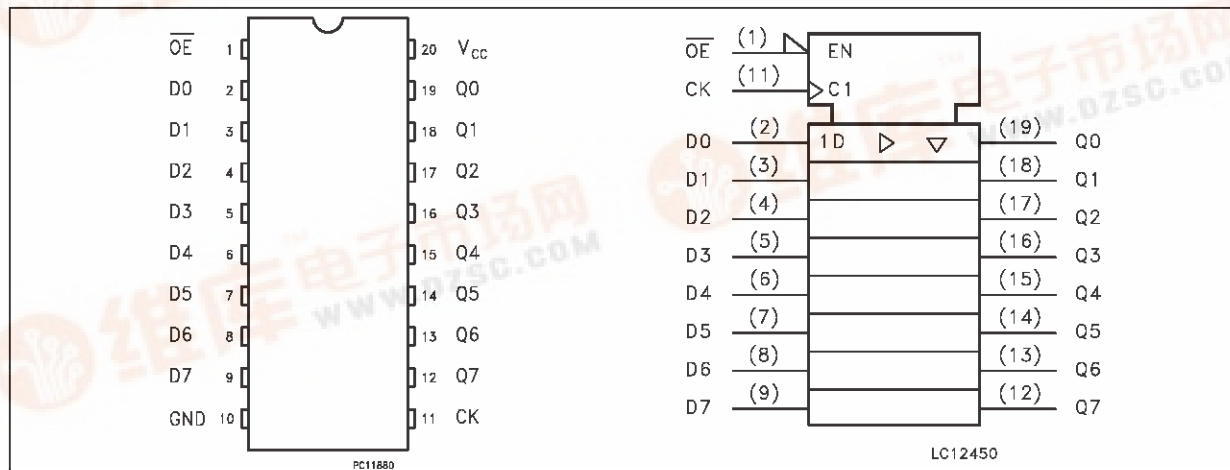

# 74VHCT574A

## INPUT EQUIVALENT CIRCUIT

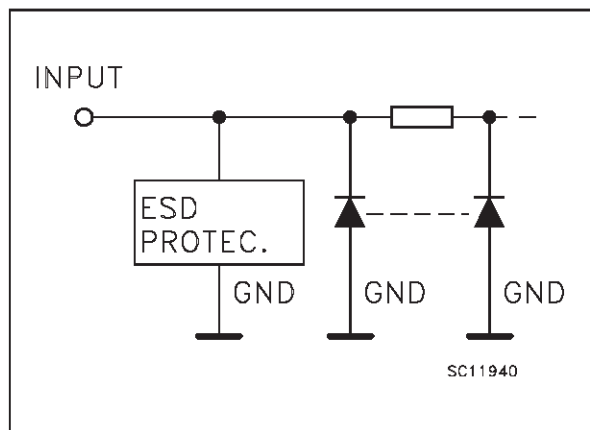

## PIN DESCRIPTION

PIN No	SYMBOL	NAME AND FUNCTION
1	$\overline{OE}$	3 State Output Enable Input (Active LOW)
2, 3, 4, 5, 6, 7, 8, 9	D0 to D7	Data Inputs
12, 13, 14, 15, 16, 17, 18, 19	Q0 to Q7	3 State Outputs
11	CLOCK	Clock Input (LOW to HIGH, edge triggered)
10	GND	Ground (0V)
20	V <sub>CC</sub>	Positive Supply Voltage

## TRUTH TABLE

INPUTS			OUTPUTS
$\overline{OE}$	CK	D	Q
H	X	X	Z
L		X	NO CHANGE
L		L	L
L		H	H

X: Don't Care  
Z: High Impedance

## LOGIC DIAGRAM

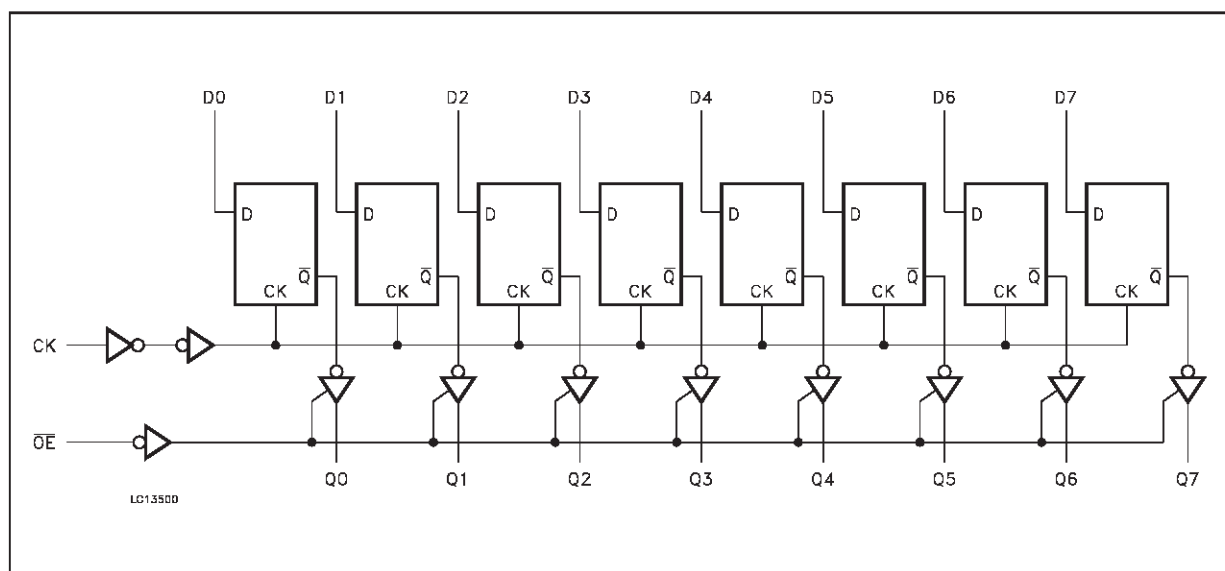

**ABSOLUTE MAXIMUM RATINGS**

Symbol	Parameter	Value	Unit
V <sub>CC</sub>	Supply Voltage	-0.5 to +7.0	V
V <sub>I</sub>	DC Input Voltage	-0.5 to +7.0	V
V <sub>O</sub>	DC Output Voltage (see note 1)	-0.5 to +7.0	V
V <sub>O</sub>	DC Output Voltage (see note 2)	-0.5 to V <sub>CC</sub> + 0.5	V
I <sub>IK</sub>	DC Input Diode Current	- 20	mA
I <sub>OK</sub>	DC Output Diode Current	± 20	mA
I <sub>O</sub>	DC Output Current	± 25	mA
I <sub>CC</sub> or I <sub>GND</sub>	DC V <sub>CC</sub> or Ground Current	± 50	mA
T <sub>stg</sub>	Storage Temperature	-65 to +150	°C
T <sub>L</sub>	Lead Temperature (10 sec)	300	°C

Absolute Maximum Ratings are those values beyond which damage to the device may occur. Functional operation under these condition is not implied.

1) Output in OFF State

2) High or Low State

**RECOMMENDED OPERATING CONDITIONS**

Symbol	Parameter	Value	Unit
V <sub>CC</sub>	Supply Voltage	4.5 to 5.5	V
V <sub>I</sub>	Input Voltage	0 to 5.5	V
V <sub>O</sub>	Output Voltage (see note 1)	0 to 5.5	V
V <sub>O</sub>	Output Voltage (see note 2)	0 to V <sub>CC</sub>	V
T <sub>op</sub>	Operating Temperature	-40 to +85	°C
dt/dv	Input Rise and Fall Time (see note 3) (V <sub>CC</sub> = 5.0 ± 0.5V)	0 to 20	ns/V

1) Output in OFF State

2) High or Low State

3) V<sub>IN</sub> from 0.8V to 2 V

## 74VHCT574A

### DC SPECIFICATIONS

Symbol	Parameter	Test Conditions		Value					Unit
				T <sub>A</sub> = 25 °C			-40 to 85 °C		
		V <sub>CC</sub> (V)		Min.	Typ.	Max.	Min.	Max.	
V <sub>IH</sub>	High Level Input Voltage	4.5 to 5.5		2			2		V
V <sub>IL</sub>	Low Level Input Voltage	4.5 to 5.5				0.8		0.8	V
V <sub>OH</sub>	High Level Output Voltage	4.5	I <sub>O</sub> = -50 μA	4.4	4.5		4.4		V
		4.5	I <sub>O</sub> = -8 mA	3.94			3.8		
V <sub>OL</sub>	Low Level Output Voltage	4.5	I <sub>O</sub> = 50 μA		0.0	0.1		0.1	V
		4.5	I <sub>O</sub> = 8 mA			0.36		0.44	
I <sub>OZ</sub>	High Impedance Output Leakage Current	4.5 to 5.5	V <sub>I</sub> = V <sub>IH</sub> or V <sub>IL</sub> V <sub>O</sub> = 0V to 5.5V			±0.25		±2.5	μA
I <sub>I</sub>	Input Leakage Current	0 to 5.5	V <sub>I</sub> = 5.5V or GND			±0.1		±1.0	μA
I <sub>CC</sub>	Quiescent Supply Current	5.5	V <sub>I</sub> = V <sub>CC</sub> or GND			4		40	μA
ΔI <sub>CC</sub>	Additional Worst Case Supply Current	5.5	One Input at 3.4V, other input at V <sub>CC</sub> or GND			1.35		1.5	mA
I <sub>OPD</sub>	Output Leakage Current	0	V <sub>OUT</sub> = 5.5V			0.5		5.0	μA

### AC ELECTRICAL CHARACTERISTICS (Input t<sub>r</sub> = t<sub>f</sub> = 3 ns)

Symbol	Parameter	Test Condition		Value					Unit	
				T <sub>A</sub> = 25 °C			-40 to 85 °C			
		V <sub>CC</sub> (V)	C <sub>L</sub> (pF)	Min.	Typ.	Max.	Min.	Max.		
t <sub>PLH</sub> t <sub>PHL</sub>	Propagation Delay Time CK to Q	5.0 <sup>(*)</sup>	15		4.1	9.4	1.0	10.5	ns	
		5.0 <sup>(*)</sup>	50		5.6	10.4	1.0	11.5		
t <sub>PZL</sub> t <sub>PZH</sub>	Output Enable Time	5.0 <sup>(*)</sup>	15	R <sub>L</sub> = 1KΩ		6.5	10.2	1.0	11.5	ns
		5.0 <sup>(*)</sup>	50			7.3	11.2	1.0	12.5	
t <sub>PLZ</sub> t <sub>PHZ</sub>	Output Disable Time	5.0 <sup>(*)</sup>	50	R <sub>L</sub> = 1KΩ		7.0	11.2	1.0	12.0	ns
f <sub>MAX</sub>	Maximum Clock Frequency	5.0 <sup>(*)</sup>	15		90	140		80	MHz	
		5.0 <sup>(*)</sup>	50		85	130				
t <sub>OSLH</sub> t <sub>OSHL</sub>	Output to Output Skew Time (note 1)	5.0 <sup>(*)</sup>	50			1.5		1.5	ns	

(\*) Voltage range is 5V ± 0.5V

Note 1: Parameter guaranteed by design. t<sub>soLH</sub> = |t<sub>PLHm</sub> - t<sub>PLHl</sub>|, t<sub>soHL</sub> = |t<sub>PHLm</sub> - t<sub>PHLl</sub>|

## CAPACITIVE CHARACTERISTICS

Symbol	Parameter	Test Conditions	Value					Unit
			T <sub>A</sub> = 25 °C			-40 to 85 °C		
			Min.	Typ.	Max.	Min.	Max.	
C <sub>IN</sub>	Input Capacitance			4	10		10	pF
C <sub>OUT</sub>	Output Capacitance			9				pF
C <sub>PD</sub>	Power Dissipation Capacitance (note 1)			25				pF

1) C<sub>PD</sub> is defined as the value of the IC's internal equivalent capacitance which is calculated from the operating current consumption without load. (Refer to Test Circuit). Average operating current can be obtained by the following equation. I<sub>CC(opr)</sub> = C<sub>PD</sub> • V<sub>CC</sub> • f<sub>IN</sub> + I<sub>CC</sub>/8 (per Flip-Flop)

## DYNAMIC SWITCHING CHARACTERISTICS

Symbol	Parameter	Test Conditions		Value					Unit
		V <sub>CC</sub> (V)		T <sub>A</sub> = 25 °C			-40 to 85 °C		
				Min.	Typ.	Max.	Min.	Max.	
V <sub>OLP</sub>	Dynamic Low Voltage Quiet Output (note 1, 2)	5.0	C <sub>L</sub> = 50 pF		1.2	1.6			V
V <sub>OLV</sub>				-1.6	-1.2				
V <sub>IHD</sub>	Dynamic High Voltage Input (note 1, 3)	5.0		3.5					
V <sub>ILD</sub>	Dynamic Low Voltage Input (note 1, 3)	5.0				1.5			

1) Worst case package.

2) Max number of outputs defined as (n). Data inputs are driven 0V to 5.0V, (n-1) outputs switching and one output at GND.

3) Max number of data inputs (n) switching, (n-1) switching 0V to 5.0V. Inputs under test switching: 5.0V to threshold (V<sub>ILD</sub>), 0V to threshold (V<sub>IHD</sub>), f=1MHz.

# 74VHCT574A

## TEST CIRCUIT

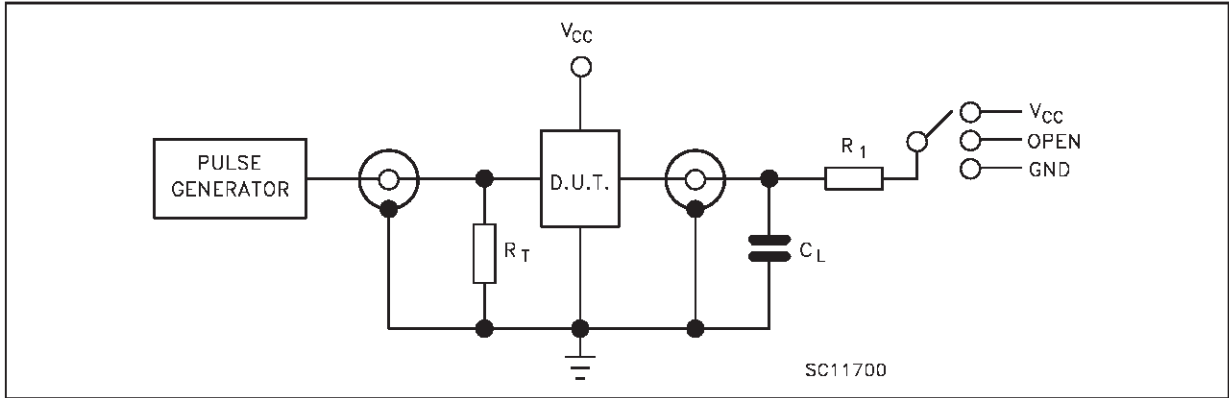

TEST	SWITCH
$t_{PLH}$ , $t_{PHL}$	Open
$t_{PZL}$ , $t_{PLZ}$	$V_{CC}$
$t_{PZH}$ , $t_{PHZ}$	GND

$C_L = 15/50$  pF or equivalent (includes jig and probe capacitance)  
 $R_L = R_1 = 1K\Omega$  or equivalent  
 $R_T = Z_{OUT}$  of pulse generator (typically  $50\Omega$ )

## WAVEFORM 1: PROPAGATION DELAYS, SETUP AND HOLD TIMES (f=1MHz; 50% duty cycle)

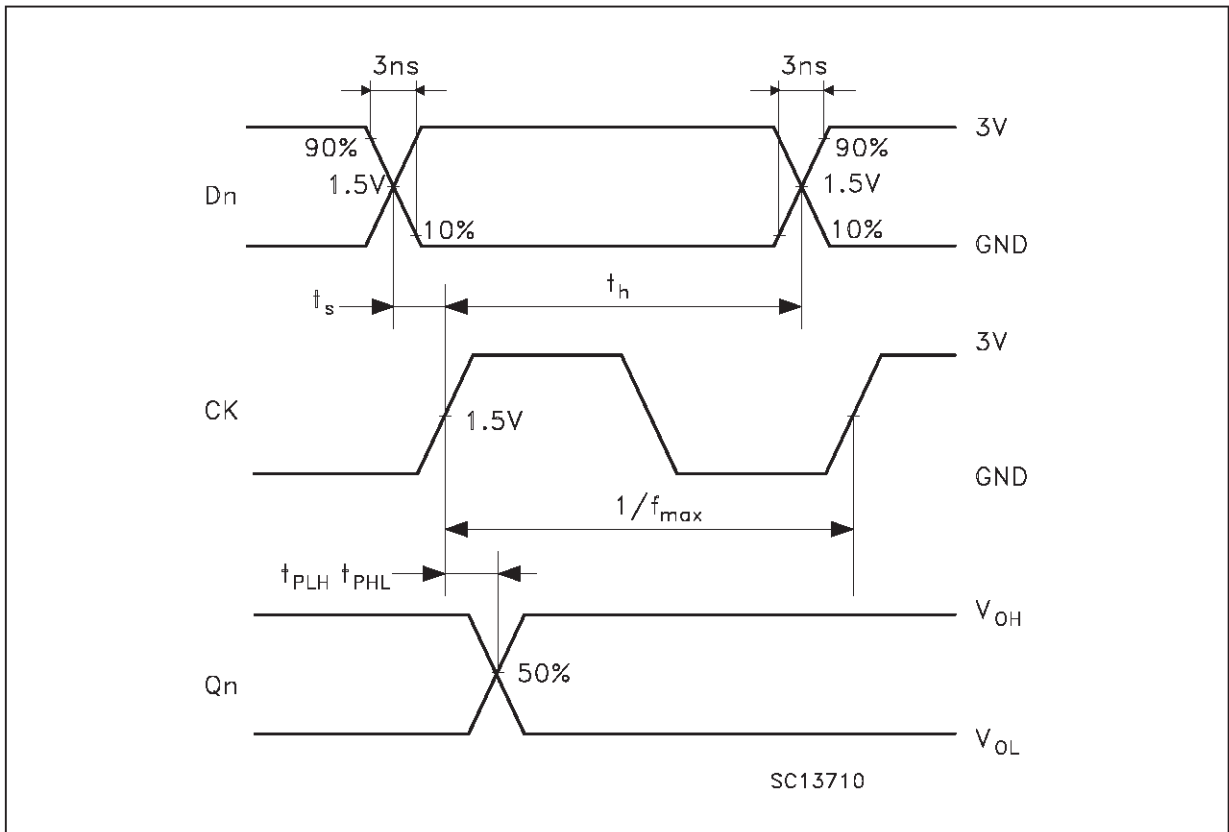

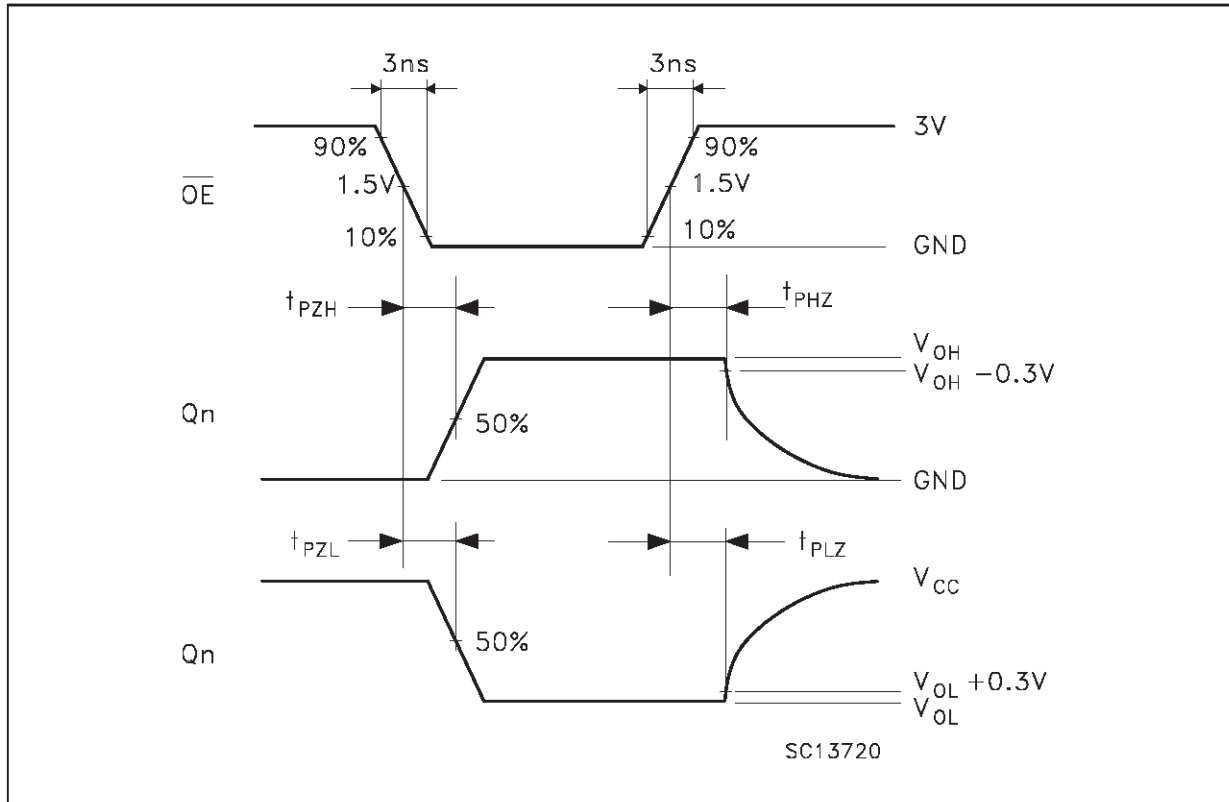
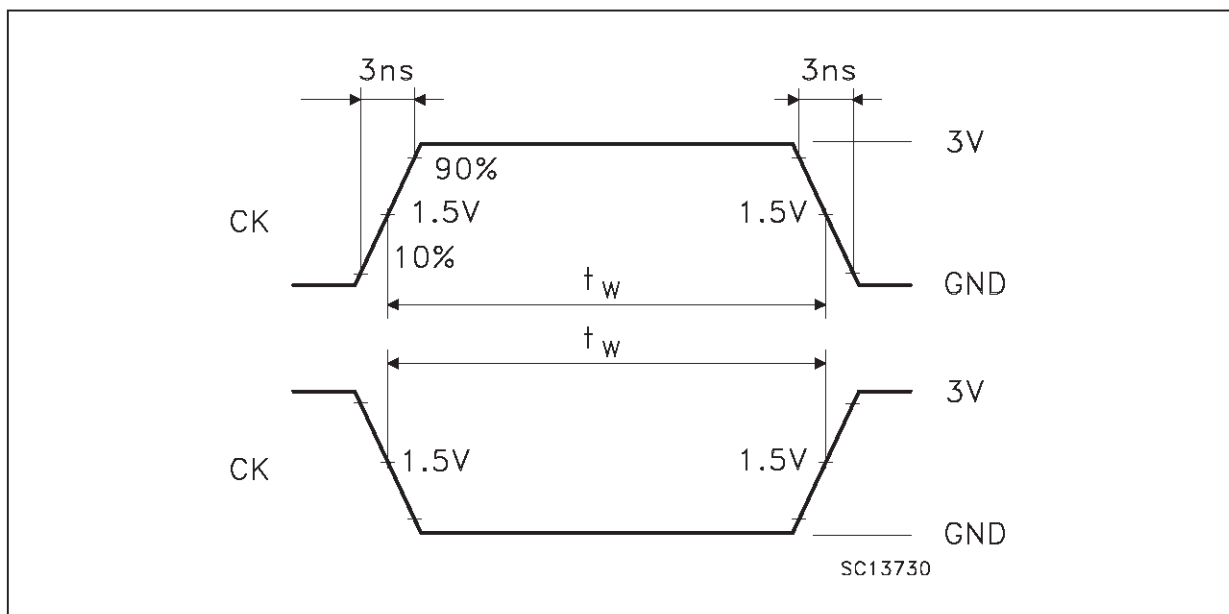
**WAVEFORM 2: OUTPUT ENABLE AND DISABLE TIMES** ( $f=1\text{MHz}$ ; 50% duty cycle)**WAVEFORM 3: PULSE WIDTH**

**SO-20 MECHANICAL DATA**

DIM.	mm			inch		
	MIN.	TYP.	MAX.	MIN.	TYP.	MAX.
A			2.65			0.104
a1	0.10		0.20	0.004		0.007
a2			2.45			0.096
b	0.35		0.49	0.013		0.019
b1	0.23		0.32	0.009		0.012
C		0.50			0.020	
c1	45 (typ.)					
D	12.60		13.00	0.496		0.512
E	10.00		10.65	0.393		0.419
e		1.27			0.050	
e3		11.43			0.450	
F	7.40		7.60	0.291		0.299
L	0.50		1.27	0.19		0.050
M			0.75			0.029
S	8 (max.)					

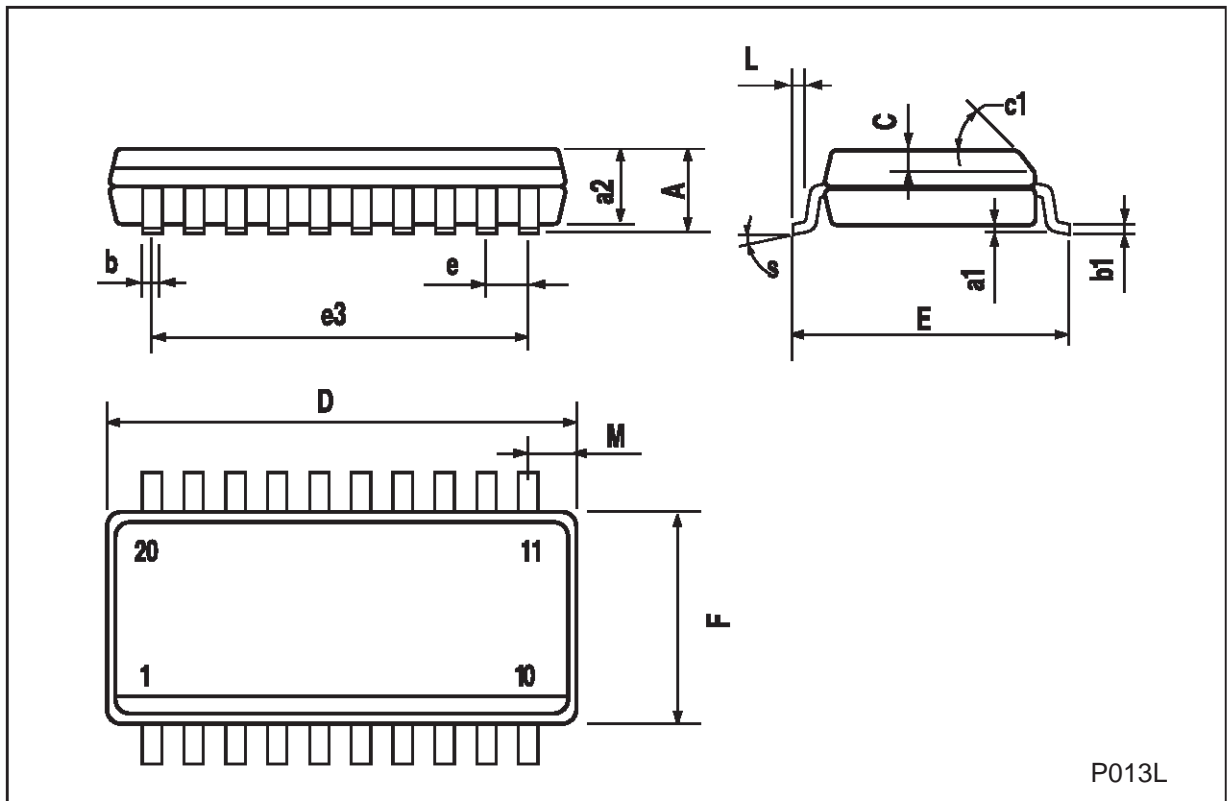



## TSSOP20 MECHANICAL DATA

DIM.	mm			inch		
	MIN.	TYP.	MAX.	MIN.	TYP.	MAX.
A			1.1			0.433
A1	0.05	0.10	0.15	0.002	0.004	0.006
A2	0.85	0.9	0.95	0.335	0.354	0.374
b	0.19		0.30	0.0075		0.0118
c	0.09		0.2	0.0035		0.0079
D	6.4	6.5	6.6	0.252	0.256	0.260
E	6.25	6.4	6.5	0.246	0.252	0.256
E1	4.3	4.4	4.48	0.169	0.173	0.176
e		0.65 BSC			0.0256 BSC	
K	0°	4°	8°	0°	4°	8°
L	0.50	0.60	0.70	0.020	0.024	0.028

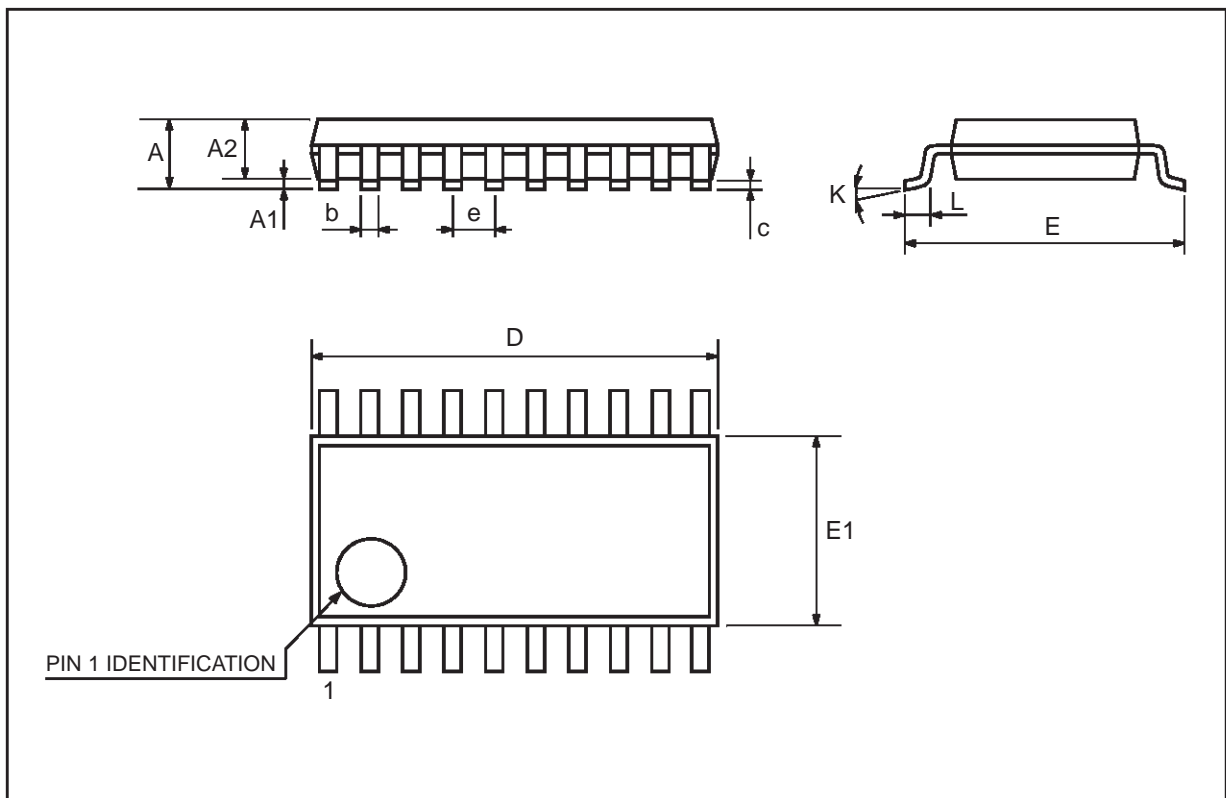

Information furnished is believed to be accurate and reliable. However, STMicroelectronics assumes no responsibility for the consequences of use of such information nor for any infringement of patents or other rights of third parties which may result from its use. No license is granted by implication or otherwise under any patent or patent rights of STMicroelectronics. Specification mentioned in this publication are subject to change without notice. This publication supersedes and replaces all information previously supplied. STMicroelectronics products are not authorized for use as critical components in life support devices or systems without express written approval of STMicroelectronics.

The ST logo is a trademark of STMicroelectronics

© 1999 STMicroelectronics – Printed in Italy – All Rights Reserved  
STMicroelectronics GROUP OF COMPANIES

Australia - Brazil - Canada - China - France - Germany - Italy - Japan - Korea - Malaysia - Malta - Mexico - Morocco - The Netherlands -  
Singapore - Spain - Sweden - Switzerland - Taiwan - Thailand - United Kingdom - U.S.A.  
<http://www.st.com>