



May 1998

## LM134/LM234/LM334 3-Terminal Adjustable Current Sources

### General Description

The LM134/LM234/LM334 are 3-terminal adjustable current sources featuring 10,000:1 range in operating current, excellent current regulation and a wide dynamic voltage range of 1V to 40V. Current is established with one external resistor and no other parts are required. Initial current accuracy is  $\pm 3\%$ . The LM134/LM234/LM334 are true floating current sources with no separate power supply connections. In addition, reverse applied voltages of up to 20V will draw only a few dozen microamperes of current, allowing the devices to act as both a rectifier and current source in AC applications.

The sense voltage used to establish operating current in the LM134 is 64 mV at 25°C and is directly proportional to absolute temperature ( $^{\circ}\text{K}$ ). The simplest one external resistor connection, then, generates a current with  $\approx +0.33\%/^{\circ}\text{C}$  temperature dependence. Zero drift operation can be obtained by adding one extra resistor and a diode.

Applications for the current sources include bias networks, surge protection, low power reference, ramp generation, LED driver, and temperature sensing. The LM134-3/

LM234-3 and LM134-6/LM234-6 are specified as true temperature sensors with guaranteed initial accuracy of  $\pm 3^{\circ}\text{C}$  and  $\pm 6^{\circ}\text{C}$ , respectively. These devices are ideal in remote sense applications because series resistance in long wire runs does not affect accuracy. In addition, only 2 wires are required.

The LM134 is guaranteed over a temperature range of  $-55^{\circ}\text{C}$  to  $+125^{\circ}\text{C}$ , the LM234 from  $-25^{\circ}\text{C}$  to  $+100^{\circ}\text{C}$  and the LM334 from  $0^{\circ}\text{C}$  to  $+70^{\circ}\text{C}$ . These devices are available in TO-46 hermetic, TO-92 and SO-8 plastic packages.

### Features

- Operates from 1V to 40V
- 0.02%/V current regulation
- Programmable from 1  $\mu\text{A}$  to 10 mA
- True 2-terminal operation
- Available as fully specified temperature sensor
- $\pm 3\%$  initial accuracy

### Connection Diagrams

SO-8  
Surface Mount Package

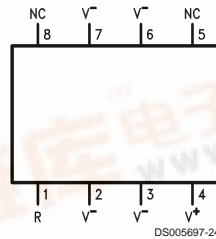

Order Number LM334M  
See NS Package Number M08A

SO-8 Alternative Pinout  
Surface Mount Package

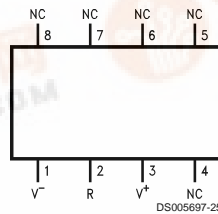

Order Number LM334SM  
See NS Package Number M08A

TO-46  
Metal Can Package

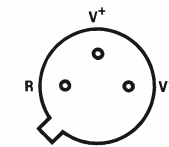

V<sup>-</sup> Pin is electrically connected to case.

Bottom View  
Order Number LM134H,  
LM134H-3, LM134H-6,  
LM234H or LM334H  
See NS Package  
Number H03H

TO-92 Plastic Package

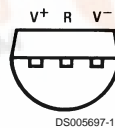

Bottom View  
Order Number LM334Z, LM234Z-3 or LM234Z-6  
See NS Package Number Z03A

LM134/LM234/LM334 3-Terminal Adjustable Current Sources



## Absolute Maximum Ratings (Note 1)

If Military/Aerospace specified devices are required, please contact the National Semiconductor Sales Office/ Distributors for availability and specifications.

V <sup>+</sup> to V <sup>-</sup> Forward Voltage	
LM134/LM234/LM334	40V
LM134-3/LM134-6/LM234-3/LM234-6	30V
V <sup>+</sup> to V <sup>-</sup> Reverse Voltage	20V
R Pin to V <sup>-</sup> Voltage	5V
Set Current	10 mA
Power Dissipation	400 mW
ESD Susceptibility (Note 6)	2000V
Operating Temperature Range (Note 5)	
LM134/LM134-3/LM134-6	-55°C to +125°C

LM234/LM234-3/LM234-6	-25°C to +100°C
LM334	0°C to +70°C

### Soldering Information

TO-92 Package (10 sec.)	260°C
TO-46 Package (10 sec.)	300°C
SO Package	
Vapor Phase (60 sec.)	215°C
Infrared (15 sec.)	220°C

See AN-450 "Surface Mounting Methods and Their Effect on Product Reliability" (Appendix D) for other methods of soldering surface mount devices.

## Electrical Characteristics (Note 2)

Parameter	Conditions	LM134/LM234			LM334			Units
		Min	Typ	Max	Min	Typ	Max	
Set Current Error, V <sup>+</sup> =2.5V, (Note 3)	10 μA ≤ I <sub>SET</sub> ≤ 1 mA			3			6	%
	1 mA < I <sub>SET</sub> ≤ 5 mA			5			8	%
	2 μA ≤ I <sub>SET</sub> < 10 μA			8			12	%
Ratio of Set Current to Bias Current	100 μA ≤ I <sub>SET</sub> ≤ 1 mA	14	18	23	14	18	26	
	1 mA ≤ I <sub>SET</sub> ≤ 5 mA		14			14		
	2 μA ≤ I <sub>SET</sub> ≤ 100 μA		18	23		18	26	
Minimum Operating Voltage	2 μA ≤ I <sub>SET</sub> ≤ 100 μA		0.8			0.8		V
	100 μA < I <sub>SET</sub> ≤ 1 mA		0.9			0.9		V
	1 mA < I <sub>SET</sub> ≤ 5 mA		1.0			1.0		V
Average Change in Set Current with Input Voltage	2 μA ≤ I <sub>SET</sub> ≤ 1 mA							
	1.5 ≤ V <sup>+</sup> ≤ 5V		0.02	0.05		0.02	0.1	%/V
	5V ≤ V <sup>+</sup> ≤ 40V		0.01	0.03		0.01	0.05	%/V
	1 mA < I <sub>SET</sub> ≤ 5 mA							
	1.5V ≤ V <sub>SET</sub> ≤ 5V		0.03			0.03		%/V
5V ≤ V <sub>SET</sub> ≤ 40V		0.02			0.02		%/V	
Temperature Dependence of Set Current (Note 4)	25 μA ≤ I <sub>SET</sub> ≤ 1 mA	0.96T	T	1.04T	0.96T	T	1.04T	
Effective Shunt Capacitance			15			15		pF

**Note 1:** "Absolute Maximum Ratings" indicate limits beyond which damage to the device may occur. Operating Ratings indicate conditions for which the device is functional, but do not guarantee specific performance limits.

**Note 2:** Unless otherwise specified, tests are performed at T<sub>J</sub>=25°C with pulse testing so that junction temperature does not change during test

**Note 3:** Set current is the current flowing into the V<sup>+</sup> pin. For the Basic 2-Terminal Current Source circuit shown on the first page of this data sheet. I<sub>SET</sub> is determined by the following formula: I<sub>SET</sub>=67.7 mV/R<sub>SET</sub> (@ 25°C). Set current error is expressed as a percent deviation from this amount. I<sub>SET</sub> increases at 0.336%/°C @ T<sub>J</sub>=25°C (227 μV/°C).

**Note 4:** I<sub>SET</sub> is directly proportional to absolute temperature (°K). I<sub>SET</sub> at any temperature can be calculated from: I<sub>SET</sub>=I<sub>0</sub> (T/T<sub>0</sub>) where I<sub>0</sub> is I<sub>SET</sub> measured at T<sub>0</sub> (°K).

**Note 5:** For elevated temperature operation, T<sub>J</sub> max is:

LM134	150°C
LM234	125°C
LM334	100°C

Thermal Resistance	TO-92	TO-46	SO-8
θ <sub>ja</sub> (Junction to Ambient)	180°C/W (0.4" leads) 160°C/W (0.125" leads)	440°C/W	165°C/W
θ <sub>jc</sub> (Junction to Case)	N/A	32°C/W	80°C/W

**Note 6:** Human body model, 100 pF discharged through a 1.5 kΩ resistor.

## Electrical Characteristics (Note 2)

Parameter	Conditions	LM134-3, LM234-3			LM134-6, LM234-6			Units
		Min	Typ	Max	Min	Typ	Max	
Set Current Error, $V^+ = 2.5V$ , (Note 3)	$100 \mu A \leq I_{SET} \leq 1 \text{ mA}$ $T_j = 25^\circ$			$\pm 1$			$\pm 2$	%
Equivalent Temperature Error				$\pm 3$			$\pm 6$	$^\circ C$
Ratio of Set Current to Bias Current	$100 \mu A \leq I_{SET} \leq 1 \text{ mA}$	14	18	26	14	18	26	
Minimum Operating Voltage	$100 \mu A \leq I_{SET} \leq 1 \text{ mA}$		0.9			0.9		V
Average Change in Set Current with Input Voltage	$100 \mu A \leq I_{SET} \leq 1 \text{ mA}$ $1.5 \leq V^+ \leq 5V$ $5V \leq V^+ \leq 30V$		0.02 0.01	0.05 0.03		0.02 0.01	0.01 0.05	%/V %/V
Temperature Dependence of Set Current (Note 4) and Equivalent Slope Error	$100 \mu A \leq I_{SET} \leq 1 \text{ mA}$	0.98T	T	1.02T	0.97T	T	1.03T	
Effective Shunt Capacitance			15			15		pF

## Typical Performance Characteristics

### Output Impedance

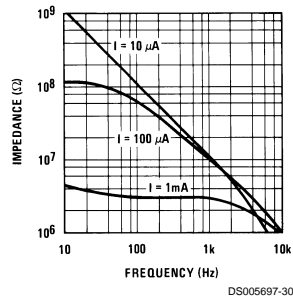

### Maximum Slew Rate Linear Operation

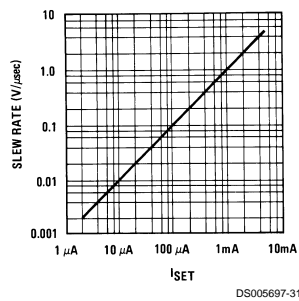

### Start-Up

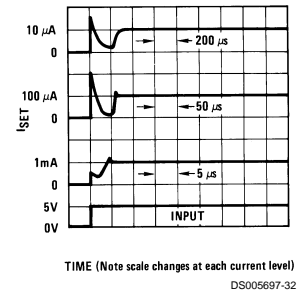

### Transient Response

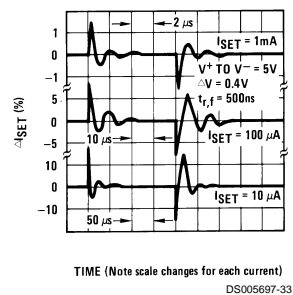

### Voltage Across $R_{SET}$ ( $V_R$ )

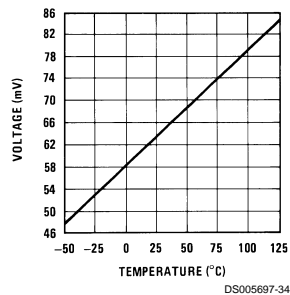

### Current Noise

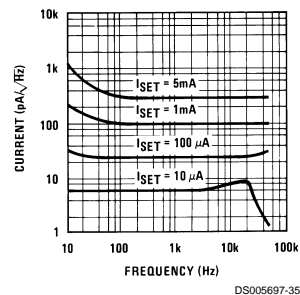

## Typical Performance Characteristics (Continued)

### Turn-On Voltage

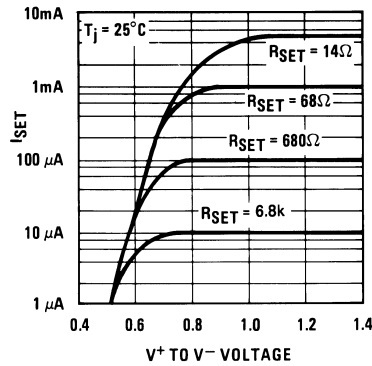

DS005697-29

### Ratio of $I_{SET}$ to $I_{BIAS}$

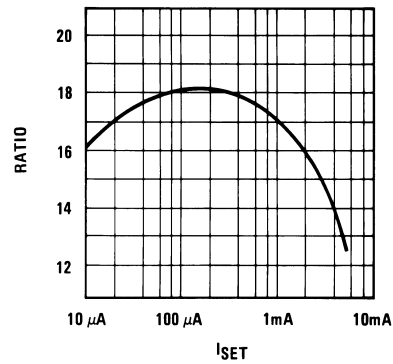

DS005697-3

## Application Hints

The LM134 has been designed for ease of application, but a general discussion of design features is presented here to familiarize the designer with device characteristics which may not be immediately obvious. These include the effects of slewing, power dissipation, capacitance, noise, and contact resistance.

### CALCULATING $R_{SET}$

The total current through the LM134 ( $I_{SET}$ ) is the sum of the current going through the SET resistor ( $I_R$ ) and the LM134's bias current ( $I_{BIAS}$ ), as shown in Figure 1.

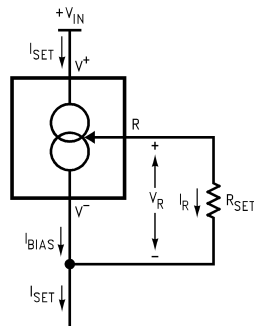

DS005697-27

FIGURE 1. Basic Current Source

A graph showing the ratio of these two currents is supplied under **Ratio of  $I_{SET}$  to  $I_{BIAS}$**  in the Typical Performance Characteristics section. The current flowing through  $R_{SET}$  is determined by  $V_R$ , which is approximately  $214 \mu\text{V}/^\circ\text{K}$  ( $64 \text{mV}/298^\circ\text{K} \sim 214 \mu\text{V}/^\circ\text{K}$ ).

$$I_{SET} = I_R + I_{BIAS} = \frac{V_R}{R_{SET}} + I_{BIAS}$$

Since (for a given set current)  $I_{BIAS}$  is simply a percentage of  $I_{SET}$ , the equation can be rewritten

$$I_{SET} = \left( \frac{V_R}{R_{SET}} \right) \left( \frac{n}{n-1} \right)$$

where  $n$  is the ratio of  $I_{SET}$  to  $I_{BIAS}$  as specified in the Electrical Characteristics Section and shown in the graph. Since  $n$  is typically 18 for  $2 \mu\text{A} \leq I_{SET} \leq 1 \text{mA}$ , the equation can be further simplified to

$$I_{SET} = \left( \frac{V_R}{R_{SET}} \right) (1.059) = \frac{227 \mu\text{V}/^\circ\text{K}}{R_{SET}}$$

for most set currents.

### SLEW RATE

At slew rates above a given threshold (see curve), the LM134 may exhibit non-linear current shifts. The slewing rate at which this occurs is directly proportional to  $I_{SET}$ . At  $I_{SET} = 10 \mu\text{A}$ , maximum  $dV/dt$  is  $0.01 \text{V}/\mu\text{s}$ ; at  $I_{SET} = 1 \text{mA}$ , the limit is  $1 \text{V}/\mu\text{s}$ . Slew rates above the limit do not harm the LM134, or cause large currents to flow.

### THERMAL EFFECTS

Internal heating can have a significant effect on current regulation for  $I_{SET}$  greater than  $100 \mu\text{A}$ . For example, each  $1 \text{V}$  increase across the LM134 at  $I_{SET} = 1 \text{mA}$  will increase junction temperature by  $\approx 0.4^\circ\text{C}$  in still air. Output current ( $I_{SET}$ ) has a temperature coefficient of  $\approx 0.33\%/^\circ\text{C}$ , so the change in current due to temperature rise will be  $(0.4)(0.33) = 0.132\%$ . This is a 10:1 degradation in regulation compared to true electrical effects. Thermal effects, therefore, must be taken into account when DC regulation is critical and  $I_{SET}$  exceeds  $100 \mu\text{A}$ . Heat sinking of the TO-46 package or the TO-92 leads can reduce this effect by more than 3:1.

### SHUNT CAPACITANCE

In certain applications, the  $15 \text{pF}$  shunt capacitance of the LM134 may have to be reduced, either because of loading problems or because it limits the AC output impedance of the current source. This can be easily accomplished by buffering the LM134 with an FET as shown in the applications. This can reduce capacitance to less than  $3 \text{pF}$  and improve regulation by at least an order of magnitude. DC characteristics (with the exception of minimum input voltage), are not affected.

## Application Hints (Continued)

### NOISE

Current noise generated by the LM134 is approximately 4 times the shot noise of a transistor. If the LM134 is used as an active load for a transistor amplifier, input referred noise will be increased by about 12 dB. In many cases, this is acceptable and a single stage amplifier can be built with a voltage gain exceeding 2000.

### LEAD RESISTANCE

The sense voltage which determines operating current of the LM134 is less than 100 mV. At this level, thermocouple or lead resistance effects should be minimized by locating the current setting resistor physically close to the device. Sockets should be avoided if possible. It takes only  $0.7\Omega$  contact resistance to reduce output current by 1% at the 1 mA level.

### SENSING TEMPERATURE

The LM134 makes an ideal remote temperature sensor because its current mode operation does not lose accuracy over long wire runs. Output current is directly proportional to absolute temperature in degrees Kelvin, according to the following formula:

$$I_{SET} = \frac{(227 \mu V/^{\circ}K)(T)}{R_{SET}}$$

Calibration of the LM134 is greatly simplified because of the fact that most of the initial inaccuracy is due to a gain term (slope error) and not an offset. This means that a calibration consisting of a gain adjustment only will trim both slope and zero at the same time. In addition, gain adjustment is a one point trim because the output of the LM134 extrapolates to zero at  $0^{\circ}K$ , independent of  $R_{SET}$  or any initial inaccuracy.

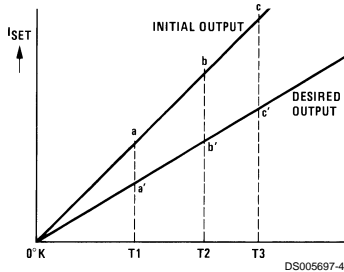

FIGURE 2. Gain Adjustment

This property of the LM134 is illustrated in the accompanying graph. Line abc is the sensor current before trimming. Line a'b'c' is the desired output. A gain trim done at  $T_2$  will move the output from b to b' and will simultaneously correct the slope so that the output at  $T_1$  and  $T_3$  will be correct. This gain trim can be done on  $R_{SET}$  or on the load resistor used to terminate the LM134. Slope error after trim will normally be less than  $\pm 1\%$ . To maintain this accuracy, however, a low temperature coefficient resistor must be used for  $R_{SET}$ .

A 33 ppm/ $^{\circ}C$  drift of  $R_{SET}$  will give a 1% slope error because the resistor will normally see about the same temperature variations as the LM134. Separating  $R_{SET}$  from the LM134 requires 3 wires and has lead resistance problems, so is not normally recommended. Metal film resistors with less than 20 ppm/ $^{\circ}C$  drift are readily available. Wire wound resistors may also be used where best stability is required.

## APPLICATION AS A ZERO TEMPERATURE COEFFICIENT CURRENT SOURCE

Adding a diode and a resistor to the standard LM134 configuration can cancel the temperature-dependent characteristic of the LM134. The circuit shown in Figure 3 balances the positive tempco of the LM134 (about  $+0.23 \text{ mV}/^{\circ}C$ ) with the negative tempco of a forward-biased silicon diode (about  $-2.5 \text{ mV}/^{\circ}C$ ).

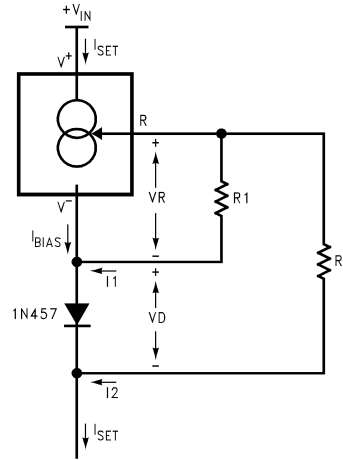

DS005697-28

FIGURE 3. Zero Tempco Current Source

The set current ( $I_{SET}$ ) is the sum of  $I_1$  and  $I_2$ , each contributing approximately 50% of the set current, and  $I_{BIAS}$ .  $I_{BIAS}$  is usually included in the  $I_1$  term by increasing the  $V_R$  value used for calculations by 5.9%. (See **CALCULATING  $R_{SET}$** .)

$$I_{SET} = I_1 + I_2 + I_{BIAS}, \text{ where}$$

$$I_1 = \frac{V_R}{R_1} \text{ and } I_2 = \frac{V_D}{R_2}$$

The first step is to minimize the tempco of the circuit, using the following equations. An example is given using a value of  $+227 \mu V/^{\circ}C$  as the tempco of the LM134 (which includes the  $I_{BIAS}$  component), and  $-2.5 \text{ mV}/^{\circ}C$  as the tempco of the diode (for best results, this value should be directly measured or obtained from the manufacturer of the diode).

$$I_{SET} = I_1 + I_2$$

$$\frac{dI_{SET}}{dT} = \frac{dI_1}{dT} + \frac{dI_2}{dT}$$

$$\approx \frac{227 \mu V/^{\circ}C}{R_1} + \frac{227 \mu V/^{\circ}C - 2.5 \text{ mV}/^{\circ}C}{R_2}$$

$$= 0 \text{ (solve for tempco} = 0)$$

$$\frac{R_2}{R_1} \approx \frac{2.5 \text{ mV}/^{\circ}C - 227 \mu V/^{\circ}C}{227 \mu V/^{\circ}C} \approx 10.0$$

With the  $R_1$  to  $R_2$  ratio determined, values for  $R_1$  and  $R_2$  should be determined to give the desired set current. The formula for calculating the set current at  $T = 25^{\circ}C$  is shown below, followed by an example that assumes the forward voltage drop across the diode ( $V_D$ ) is 0.6V, the voltage across  $R_1$  is 67.7 mV (64 mV + 5.9% to account for  $I_{BIAS}$ ), and  $R_2/R_1 = 10$  (from the previous calculations).

## Application Hints (Continued)

$$\begin{aligned}
 I_{SET} &= I_1 + I_2 + I_{BIAS} \\
 &= \frac{V_R}{R_1} + \frac{V_R + V_D}{R_2} \\
 &\approx \frac{67.7 \text{ mV}}{R_1} + \frac{67.7 \text{ mV} + 0.6 \text{ V}}{10.0 R_1} \\
 I_{SET} &\approx \frac{0.134 \text{ V}}{R_1}
 \end{aligned}$$

This circuit will eliminate most of the LM134's temperature coefficient, and it does a good job even if the estimates of the diode's characteristics are not accurate (as the following example will show). For lowest tempco with a specific diode at the desired  $I_{SET}$ , however, the circuit should be built and tested over temperature. If the measured tempco of  $I_{SET}$  is positive,  $R_2$  should be reduced. If the resulting tempco is negative,  $R_2$  should be increased. The recommended diode for use in this circuit is the 1N457 because its tempco is centered at 11 times the tempco of the LM134, allowing  $R_2 = 10 R_1$ . You can also use this circuit to create a current source with non-zero tempcos by setting the tempco component of the tempco equation to the desired value instead of 0.

EXAMPLE: A 1 mA, Zero-Tempco Current Source

First, solve for  $R_1$  and  $R_2$ :

$$\begin{aligned}
 I_{SET} \approx 1 \text{ mA} &= \frac{0.134 \text{ V}}{R_1} \\
 R_1 &= 134 \Omega = 10 R_2 \\
 R_2 &= 13.4 \Omega
 \end{aligned}$$

The values of  $R_1$  and  $R_2$  can be changed to standard 1% resistor values ( $R_1 = 133 \Omega$  and  $R_2 = 1.33 \text{ k}\Omega$ ) with less than a 0.75% error.

If the forward voltage drop of the diode was 0.65V instead of the estimate of 0.6V (an error of 8%), the actual set current will be

$$\begin{aligned}
 I_{SET} &= \frac{67.7 \text{ mV}}{R_1} + \frac{67.7 \text{ mV} + 0.65 \text{ V}}{R_2} \\
 &= \frac{67.7 \text{ mV}}{133} + \frac{67.7 \text{ mV} + 0.65 \text{ V}}{1330} \\
 &= 1.049 \text{ mA}
 \end{aligned}$$

an error of less than 5%.

If the estimate for the tempco of the diode's forward voltage drop was off, the tempco cancellation is still reasonably effective. Assume the tempco of the diode is 2.6 mV/°C instead of 2.5 mV/°C (an error of 4%). The tempco of the circuit is now:

$$\begin{aligned}
 \frac{dI_{SET}}{dT} &= \frac{dI_1}{dT} + \frac{dI_2}{dT} \\
 &= \frac{227 \mu\text{V}/^\circ\text{C}}{133 \Omega} + \frac{227 \mu\text{V}/^\circ\text{C} - 2.6 \text{ mV}/^\circ\text{C}}{1330 \Omega} \\
 &= -77 \text{ nA}/^\circ\text{C}
 \end{aligned}$$

A 1 mA LM134 current source with no temperature compensation would have a set resistor of 68Ω and a resulting tempco of

$$\frac{227 \mu\text{V}/^\circ\text{C}}{68 \Omega} = 3.3 \mu\text{A}/^\circ\text{C}$$

So even if the diode's tempco varies as much as ±4% from its estimated value, the circuit still eliminates 98% of the LM134's inherent tempco.

## Typical Applications

### Ground Referred Fahrenheit Thermometer

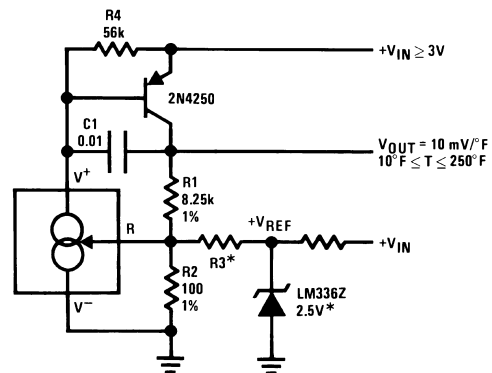

\*Select  $R_3 = V_{REF}/583 \mu\text{A}$ .  $V_{REF}$  may be any stable positive voltage  $\geq 2\text{V}$ . Trim  $R_3$  to calibrate.

## Typical Applications (Continued)

### Terminating Remote Sensor for Voltage Output

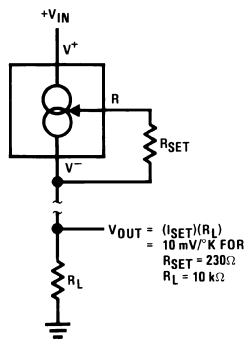

DS005697-14

### Low Output Impedance Thermometer

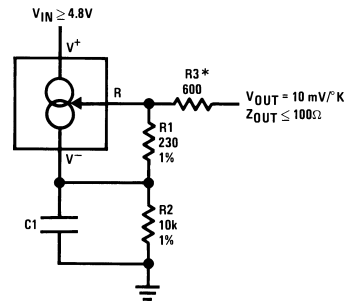

DS005697-6

\*Output impedance of the LM134 at the "R" pin is approximately

$$\frac{-R_2}{16}$$

where  $R_2$  is the equivalent external resistance connected from the  $V^-$  pin to ground. This negative resistance can be reduced by a factor of 5 or more by inserting an equivalent resistor  $R_3 = (R_2/16)$  in series with the output.

### Low Output Impedance Thermometer

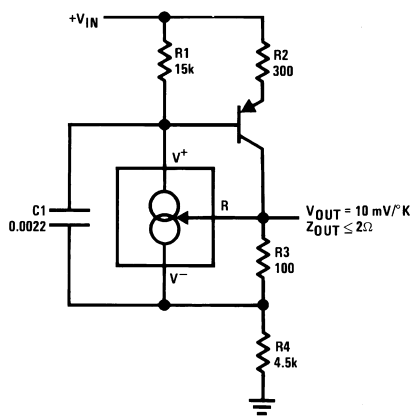

DS005697-16

### Higher Output Current

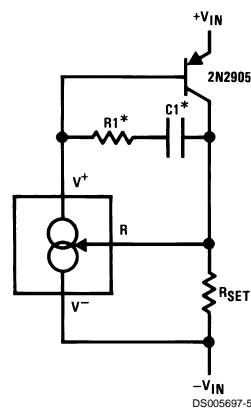

DS005697-5

\*Select R1 and C1 for optimum stability

### Basic 2-Terminal Current Source

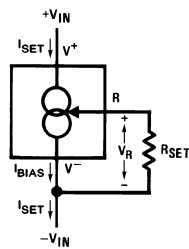

DS005697-1

## Typical Applications (Continued)

Micropower Bias

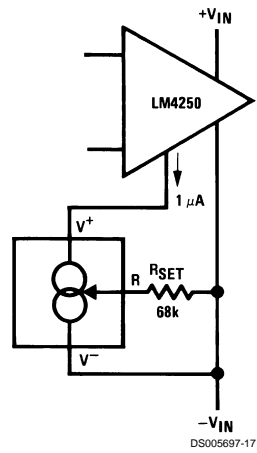

Low Input Voltage Reference Driver

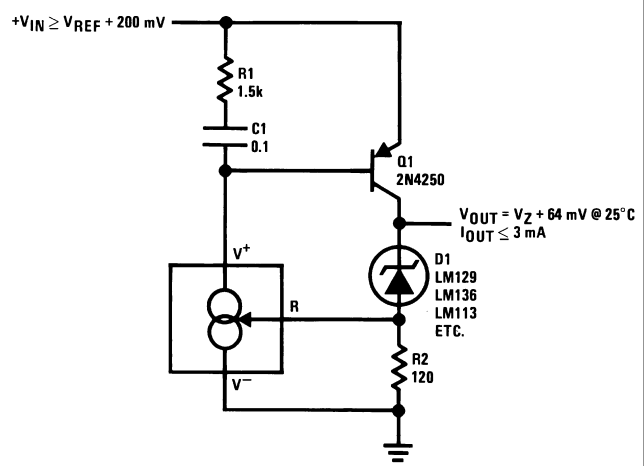

Ramp Generator

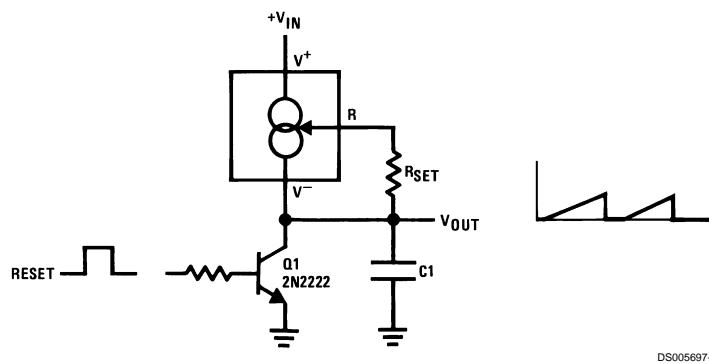



## Typical Applications (Continued)

1.2V Reference Operates on 10  $\mu$ A and 2V

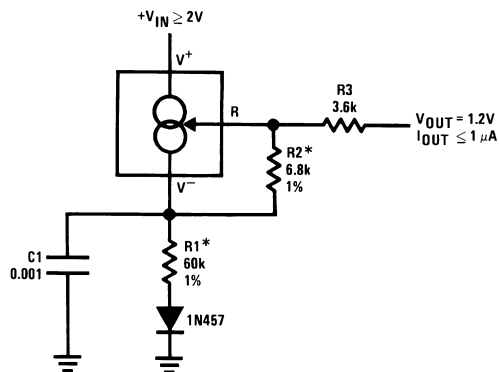

DS005697-20

\*Select ratio of R1 to R2 to obtain zero temperature drift

1.2V Regulator with 1.8V Minimum Input

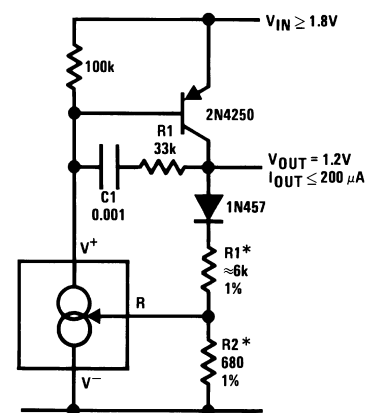

DS005697-7

\*Select ratio of R1 to R2 for zero temperature drift

Zener Biasing

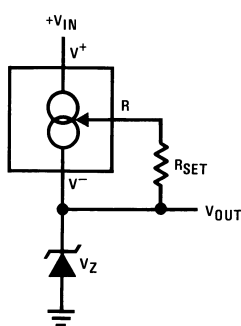

DS005697-49

Alternate Trimming Technique

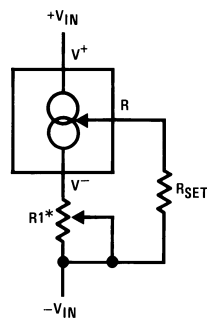

DS005697-50

\*For  $\pm 10\%$  adjustment, select RSET 10% high, and make R1 = 3 RSET

Buffer for Photoconductive Cell

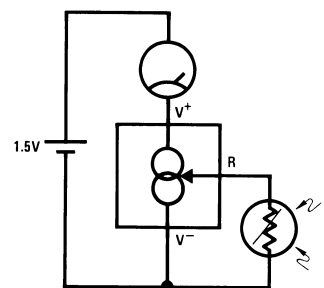

DS005697-51

FET Cascoding for Low Capacitance and/or Ultra High Output Impedance

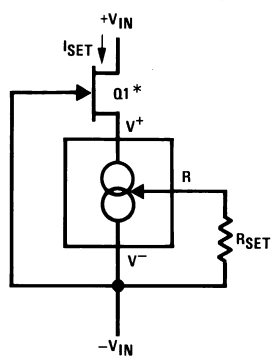

DS005697-21

\*Select Q1 or Q2 to ensure at least 1V across the LM134.  $V_p (1 - I_{SET}/I_{DSS}) \geq 1.2V$ .

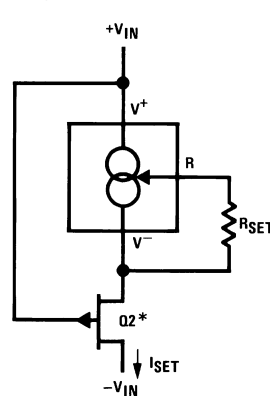

DS005697-22

## Typical Applications (Continued)

Generating Negative Output Impedance

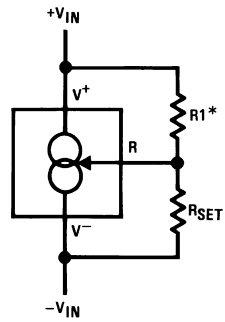

DS005697-23

\* $Z_{OUT} \approx -16 \cdot R1$  ( $R1/V_{IN}$  must not exceed  $I_{SET}$ )

In-Line Current Limiter

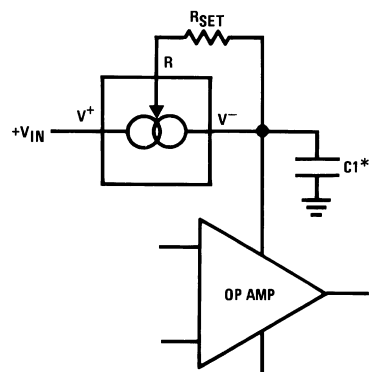

DS005697-9

\*Use minimum value required to ensure stability of protected device. This minimizes inrush current to a direct short.

## Schematic Diagram

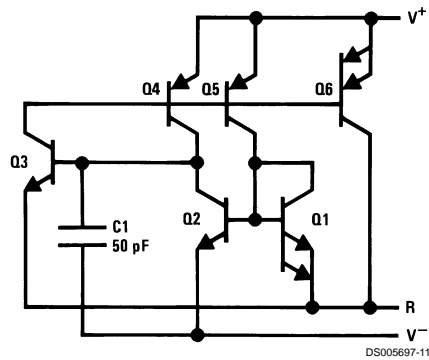

DS005697-11

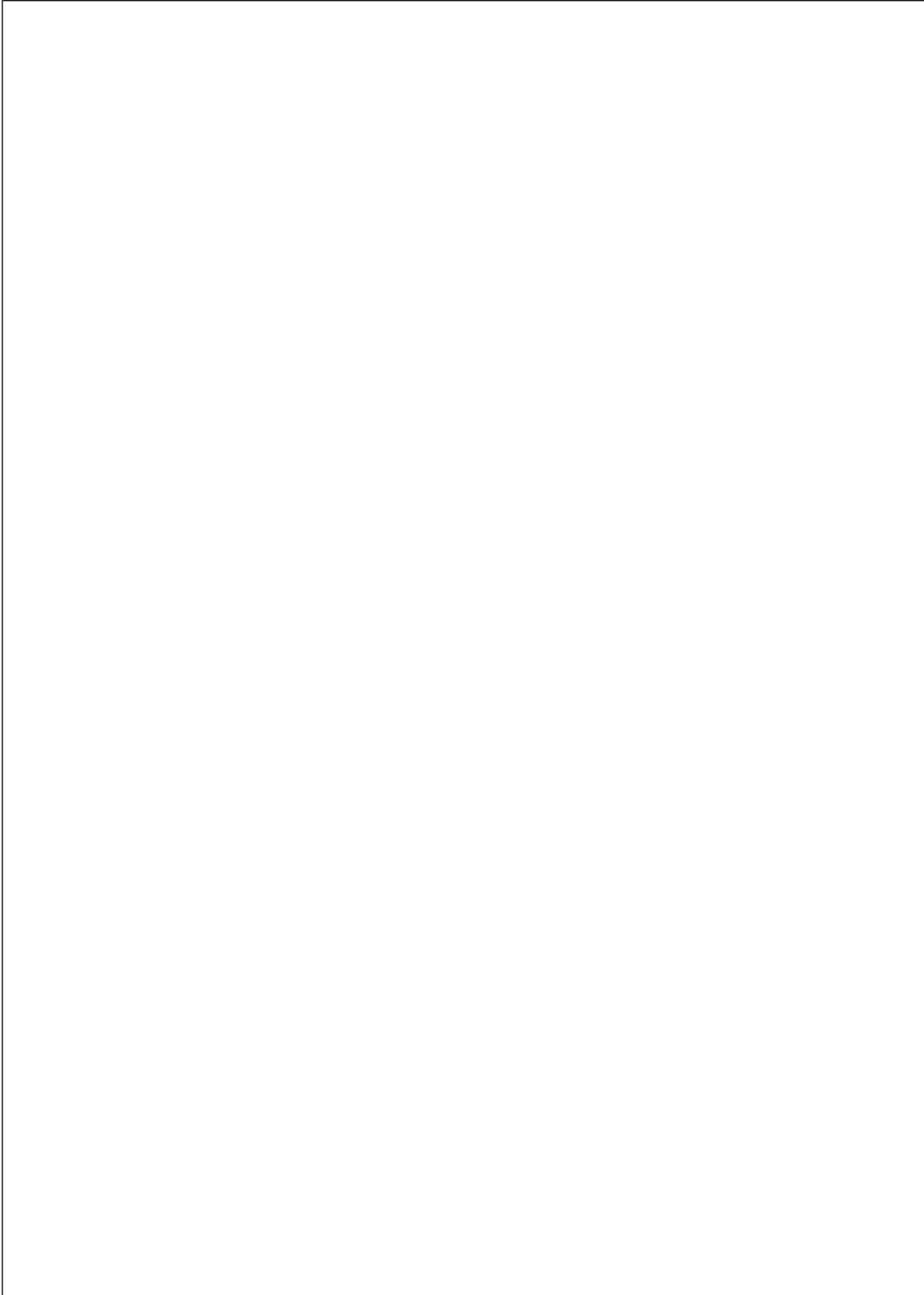

**Physical Dimensions** inches (millimeters) unless otherwise noted

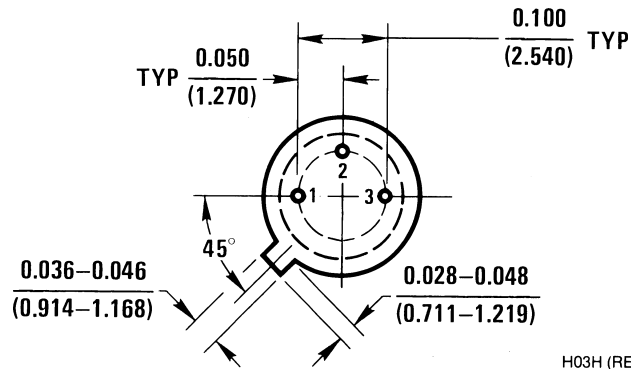
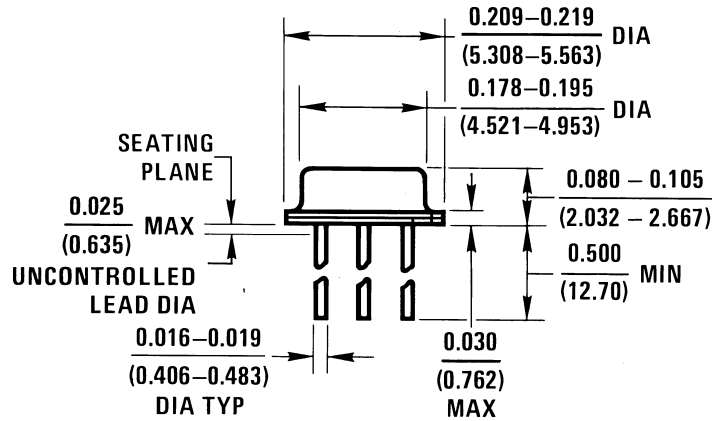

H03H (REV C)

Order Number LM134H, LM134H-3,  
LM134H-6, LM234H or LM334H  
NS Package Number H03H

**Physical Dimensions** inches (millimeters) unless otherwise noted (Continued)

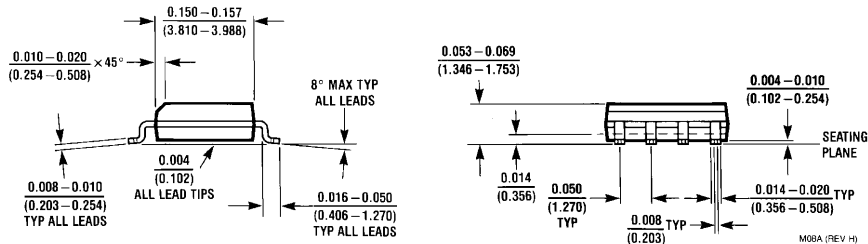
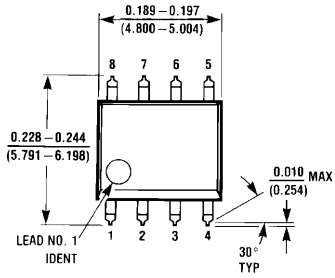

**SO Package (M)**  
**Order Number LM334M or LM334SM**  
**NS Package Number M08A**

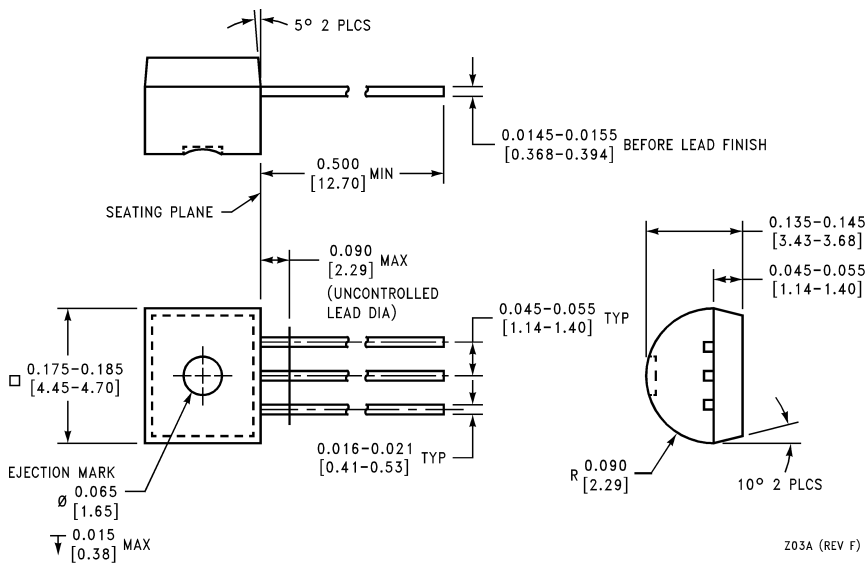

**Order Number LM334Z, LM234Z-3 or LM234Z-6**  
**NS Package Number Z03A**

**LIFE SUPPORT POLICY**

NATIONAL'S PRODUCTS ARE NOT AUTHORIZED FOR USE AS CRITICAL COMPONENTS IN LIFE SUPPORT DEVICES OR SYSTEMS WITHOUT THE EXPRESS WRITTEN APPROVAL OF THE PRESIDENT OF NATIONAL SEMICONDUCTOR CORPORATION. As used herein:

1. Life support devices or systems are devices or systems which, (a) are intended for surgical implant into the body, or (b) support or sustain life, and whose failure to perform when properly used in accordance with instructions for use provided in the labeling, can be reasonably expected to result in a significant injury to the user.
2. A critical component is any component of a life support device or system whose failure to perform can be reasonably expected to cause the failure of the life support device or system, or to affect its safety or effectiveness.



**National Semiconductor Corporation**  
Americas  
Tel: 1-800-272-9959  
Fax: 1-800-737-7018  
Email: support@nsc.com

[www.national.com](http://www.national.com)

**National Semiconductor Europe**  
Fax: +49 (0) 1 80-530 85 86  
Email: europe.support@nsc.com  
Deutsch Tel: +49 (0) 1 80-530 85 85  
English Tel: +49 (0) 1 80-532 78 32  
Français Tel: +49 (0) 1 80-532 93 58  
Italiano Tel: +49 (0) 1 80-534 16 80

**National Semiconductor Asia Pacific Customer Response Group**  
Tel: 65-2544466  
Fax: 65-2504466  
Email: sea.support@nsc.com

**National Semiconductor Japan Ltd.**  
Tel: 81-3-5639-7560  
Fax: 81-3-5639-7507