

June 1992

LM1851 Ground Fault Interrupter

General Description

The LM1851 is designed to provide ground fault protection for AC power outlets in consumer and industrial environments. Ground fault currents greater than a presettable threshold value will trigger an external SCR-driven circuit breaker to interrupt the AC line and remove the fault condition. In addition to detection of conventional hot wire to ground faults, the neutral fault condition is also detected.

Full advantage of the U.S. UL943 timing specification is taken to insure maximum immunity to false triggering due to line noise. Special features include circuitry that rapidly resets the timing capacitor in the event that noise pulses introduce unwanted charging currents and a memory circuit that allows firing of even a sluggish breaker on either half-cycle of the line voltage when external full-wave rectification is used.

Features

- Internal power supply shunt regulator
- Externally programmable fault current threshold
- Externally programmable fault current integration time
- Direct interface to SCR
- Operates under line reversal; both load vs line and hot vs neutral
- Detects neutral line faults

Block and Connection Diagram

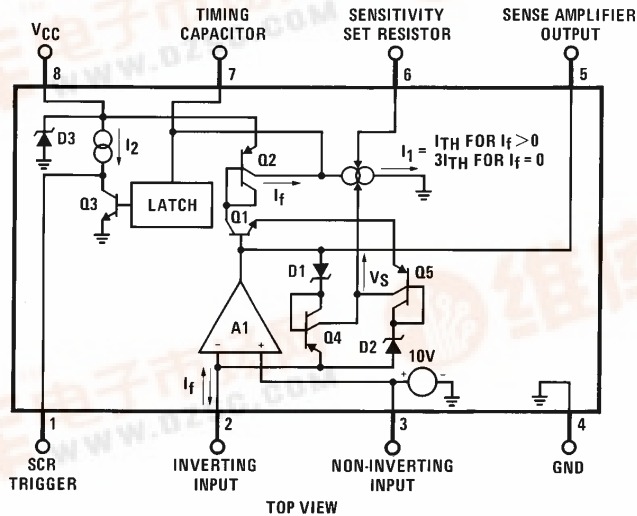

Order Number LM1851M or LM1851N
See NS Package Number M08A or N08E

LM1851 Ground Fault Interrupter



Absolute Maximum Ratings

If Military/Aerospace specified devices are required, please contact the National Semiconductor Sales Office/Distributors for availability and specifications.

| | |
|-----------------------------|-----------------|
| Supply Current | 19 mA |
| Power Dissipation (Note 1) | 1250 mW |
| Operating Temperature Range | -40°C to +70°C |
| Storage Temperature Range | -55°C to +150°C |

Soldering Information

| | |
|--------------------------------|-------|
| Dual-In-Line Package (10 sec.) | 260°C |
| Small Outline Package | |
| Vapor Phase (60 sec.) | 215°C |
| Infrared (15 sec.) | 220°C |

See AN-450 "Surface Mounting and Their Effects on Product Reliability" for other methods of soldering surface mount devices.

DC Electrical Characteristics $T_A = 25^\circ\text{C}$, $I_{SS} = 5\text{ mA}$

| Parameter | Conditions | Min | Typ | Max | Units |
|--|--|-----|------|-----|---------------------------|
| Power Supply Shunt Regulator Voltage | Pin 8, Average Value | 22 | 26 | 30 | V |
| Latch Trigger Voltage | Pin 7 | 15 | 17.5 | 20 | V |
| Sensitivity Set Voltage | Pin 8 to Pin 6 | 6 | 7 | 8.2 | V |
| Output Drive Current | Pin 1, With Fault | 0.5 | 1 | 2.4 | mA |
| Output Saturation Voltage | Pin 1, Without Fault | | 100 | 240 | mV |
| Output Saturation Resistance | Pin 1, Without Fault | | 100 | | Ω |
| Output External Current Sinking Capability | Pin 1, Without Fault, $V_{pin\ 1}$ Held to 0.3V (Note 4) | 2.0 | 5 | | mA |
| Noise Integration Sink Current Ratio | Pin 7, Ratio of Discharge Currents Between No Fault and Fault Conditions | 2.0 | 2.8 | 3.6 | $\mu\text{A}/\mu\text{A}$ |

AC Electrical Characteristics $T_A = 25^\circ\text{C}$, $I_{SS} = 5\text{ mA}$

| Parameter | Conditions | Min | Typ | Max | Units |
|--|--|-----|-----|-----|-------|
| Normal Fault Current Sensitivity | Figure 1 (Note 3) | 3 | 5 | 7 | mA |
| Normal Fault Trip Time | 500 Ω Fault, Figure 2 (Note 2) | | 18 | | ms |
| Normal Fault with Grounded Neutral Fault Trip Time | 500 Ω Normal Fault, 2 Ω Neutral, Figure 2 (Note 2) | | 18 | | ms |

Note 1: For operation in ambient temperatures above 25°C, the device must be derated based on a 125°C maximum junction temperature and a thermal resistance of 80°C/W junction to ambient for the DIP and 162°C/W for the SO Package.

Note 2: Average of 10 trials.

Note 3: Required UL sensitivity tolerance is such that external trimming of LM1851 sensitivity will be necessary.

Note 4: This externally applied current is in addition to the internal "output drive current" source.

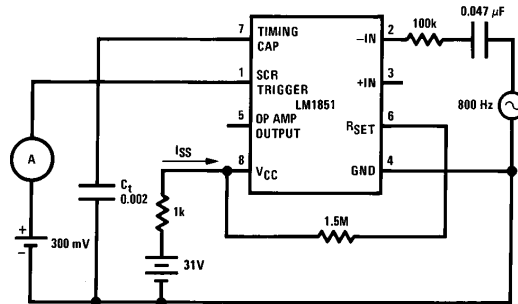
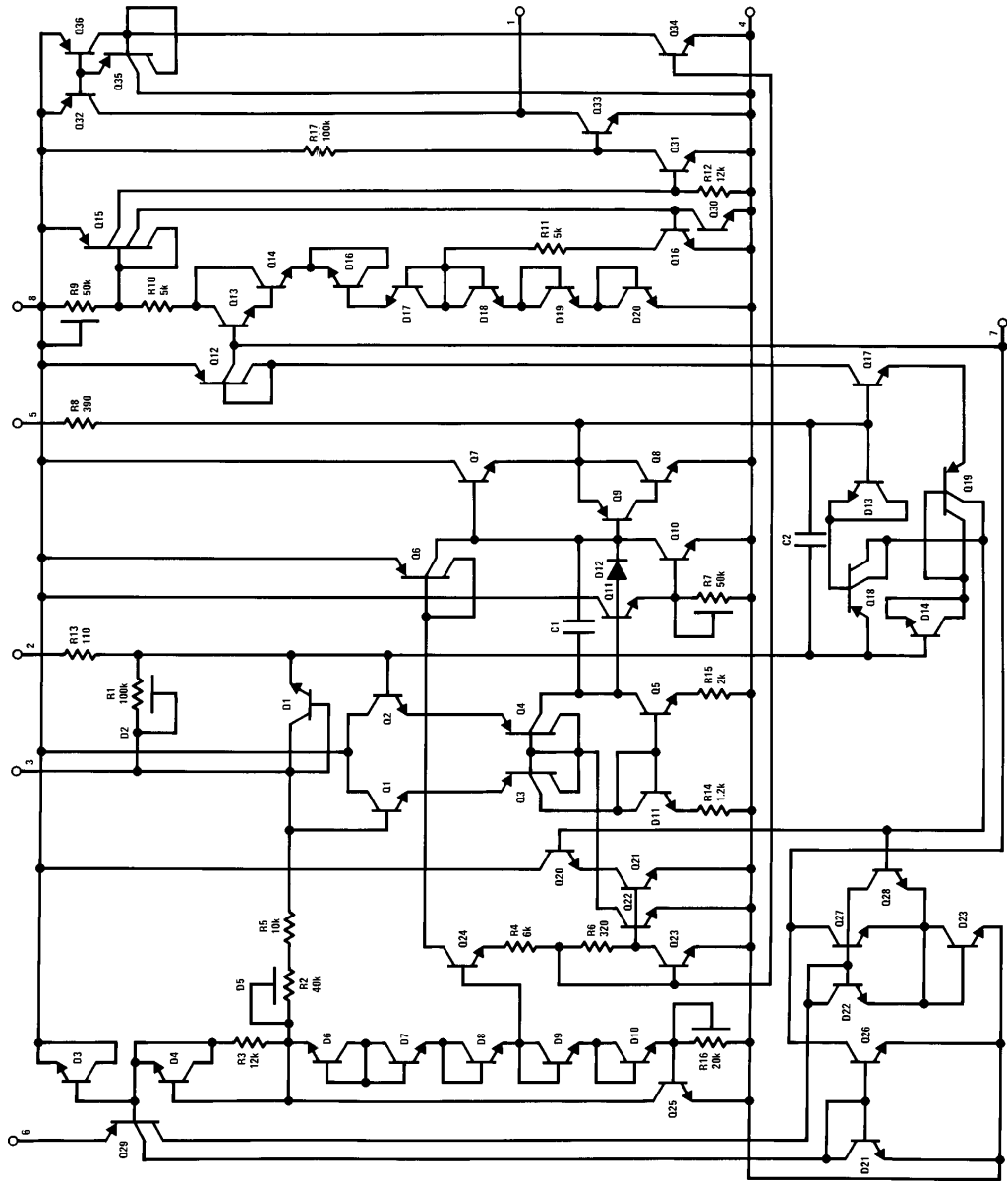

FIGURE 1. Normal Fault Sensitivity Test Circuit

TL/H/5177-2

Internal Schematic Diagram



TL/H/5177-3

Typical Performance Characteristics

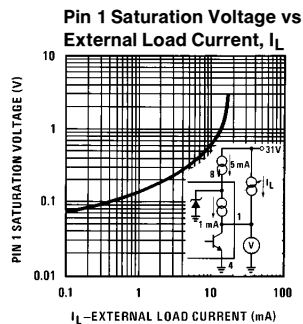
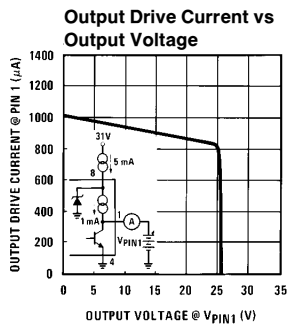
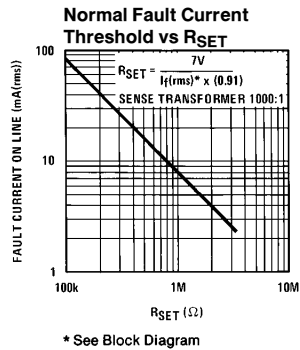
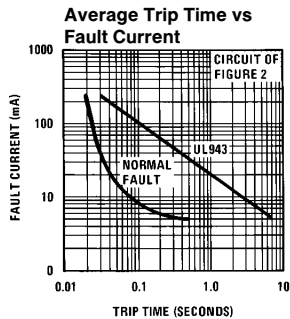

TL/H/5177-4

Circuit Description

(Refer to Block and Connection Diagram)

The LM1851 operates from 26V as set by an internal shunt regulator, D3. In the absence of a fault ($I_f=0$) the feedback path status signal (V_S) is correspondingly zero. Under these conditions the capacitor discharges current, I_1 , sits quiescently at three times its threshold value, I_{TH} , so that noise induced charge on the timing capacitor will be rapidly removed. When a fault current, I_f , is induced in the secondary of the external sense transformer, the operational amplifier, A1, uses feedback to force a virtual ground at the input as it

extracts I_f . The presence of I_f during either half-cycle will cause V_S to go high, which in turn changes I_1 from $3I_{TH}$ to I_{TH} . Although I_{TH} discharges the timing capacitor during both half-cycles of the line, I_f only charges the capacitor during the half-cycle in which I_f exits pin 2. Thus during one half-cycle $I_f - I_{TH}$ charges the timing capacitor, while during the other half-cycle I_{TH} discharges it. When the capacitor voltage reaches 17.5V, the latch engages and turns off Q3 permitting I_2 to drive the gate of an SCR.

Application Circuits

A typical ground fault interrupter circuit is shown in *Figure 2*. It is designed to operate on 120 V_{AC} line voltage with 5 mA normal fault sensitivity.

A full-wave rectifier bridge and a 15k/2W resistor are used to supply the DC power required by the IC. A 1 μF capacitor at pin 8 used to filter the ripple of the supply voltage and is also connected across the SCR to allow firing of the SCR on either half-cycle. When a fault causes the SCR to trigger, the circuit breaker is energized and line voltage is removed from the load. At this time no fault current flows and the IC discharge current increases from I_{TH} to 3I_{TH} (see Circuit Description and Block Diagram). This quickly resets both the timing capacitor and the output latch. At this time the circuit breaker can be reset and the line voltage again supplied to the load, assuming the fault has been removed. A 1000:1 sense transformer is used to detect the normal fault. The fault current, which is basically the difference current between the hot and neutral lines, is stepped down by 1000 and fed into the input pins of the operational amplifier through a 10 μF capacitor. The 0.0033 μF capacitor between pin 2 and pin 3 and the 200 pF between pins 3 and 4 are added to obtain better noise immunity. The normal fault sensitivity is determined by the timing capacitor discharging current, I_{TH}. I_{TH} can be calculated by:

$$I_{TH} = \frac{7V}{R_{SET}} \div 2 \quad (1)$$

At the decision point, the average fault current just equals the threshold current, I_{TH}.

$$I_{TH} = \frac{I_f(rms)}{2} \times 0.91 \quad (2)$$

where I_{f(rms)} is the rms input fault current to the operational amp and the factor of 2 is due to the fact that I_f charges the timing capacitor only during one half-cycle, while I_{TH} discharges the capacitor continuously. The factor 0.91 converts the rms value to an average value. Combining equations (1) and (2) we have

$$R_{SET} = \frac{7V}{I_f(rms) \times 0.91} \quad (3)$$

For example, to obtain 5 mA(rms) sensitivity for the circuit in *Figure 2* we have:

$$R_{SET} = \frac{7V}{5 \text{ mA} \times 0.91} = 1.5M \Omega \quad (4)$$

The correct value for R_{SET} can also be determined from the characteristic curve that plots equation (3). Note that this is an approximate calculation; the exact value of R_{SET} depends on the specific sense transformer used and LM1851 tolerances. Inasmuch as UL943 specifies a sensitivity "window" of 4 mA–6 mA, provision should be made to adjust R_{SET} on a per-product basis.

Independent of setting sensitivity, the desired integration time can be obtained through proper selection of the timing capacitor, C_t. Due to the large number of variables involved, proper selection of C_t is best done empirically. The following design example, then should only be used as a guideline.

Assume the goal is to meet UL943 timing requirements. Also assume that worst case timing occurs during GF1

start-up (S1 closure) with both a heavy normal fault and a 2Ω grounded neutral fault present. This situation is shown diagrammatically below.

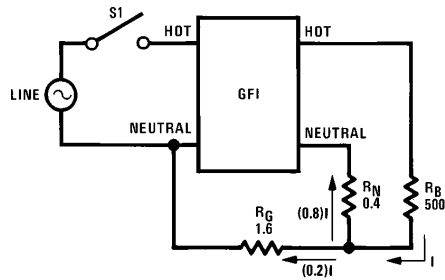

TL/H/5177-5

UL943 specifies ≤25 ms average trip time under these conditions. Calculation of C_t based upon charging currents due to normal fault only is as follows:

≤25 ms Specification

–3 ms GFI turn-on time (15k and 1 μF)

–8 ms Potential loss of one half-cycle due to fault current sense of half-cycles only

–4 ms Time required to open a sluggish circuit breaker

≤10 ms Maximum integration time that could be allowed

8 ms Value of integration time that accommodates component tolerances and other variables

$$C_t = \frac{I \times T}{V} \quad (5)$$

where T = integration time

V = threshold voltage

I = average fault current into C_t

$$I = \underbrace{\left(\frac{120 V_{AC}(rms)}{R_B} \right)}_{\text{heavy fault current generated (swamps } I_{TH})} \times \underbrace{\left(\frac{R_N}{R_G + R_N} \right)}_{\text{portion of fault current shunted around GFI}}$$

$$\times \underbrace{\left(\frac{1 \text{ turn}}{1000 \text{ turns}} \right)}_{\text{current division of input sense transformer}} \times \underbrace{\left(\frac{1}{2} \right)}_{\text{C}_t \text{ charging on half-cycles only}} \times \underbrace{(0.91)}_{\text{rms to average conversion}} \quad (6)$$

therefore:

$$C_t = \frac{\left[\left(\frac{120}{500} \right) \times \left(\frac{0.4}{1.6 + 0.4} \right) \times \left(\frac{1}{1000} \right) \times \left(\frac{1}{2} \right) \times (0.91) \right] \times 0.0008}{17.5} \quad (7)$$

$$C_t = 0.01 \mu F$$

Definition of Terms

Normal Fault: An unintentional electrical path, R_B , between the load terminal of the hot line and the ground, as shown by the dashed lines.

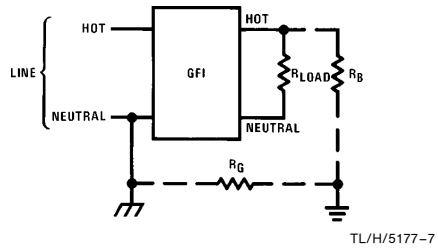

Normal Fault plus Grounded Neutral Fault: The combination of the normal fault and the grounded neutral fault, as shown by the dashed lines.

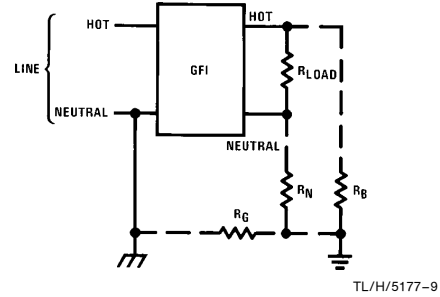

Grounded Neutral Fault: An unintentional electrical path between the load terminal of the neutral line and the ground, as shown by the dashed lines.

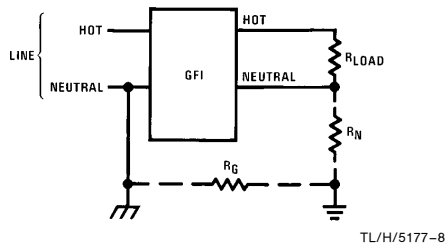

Physical Dimensions inches (millimeters)

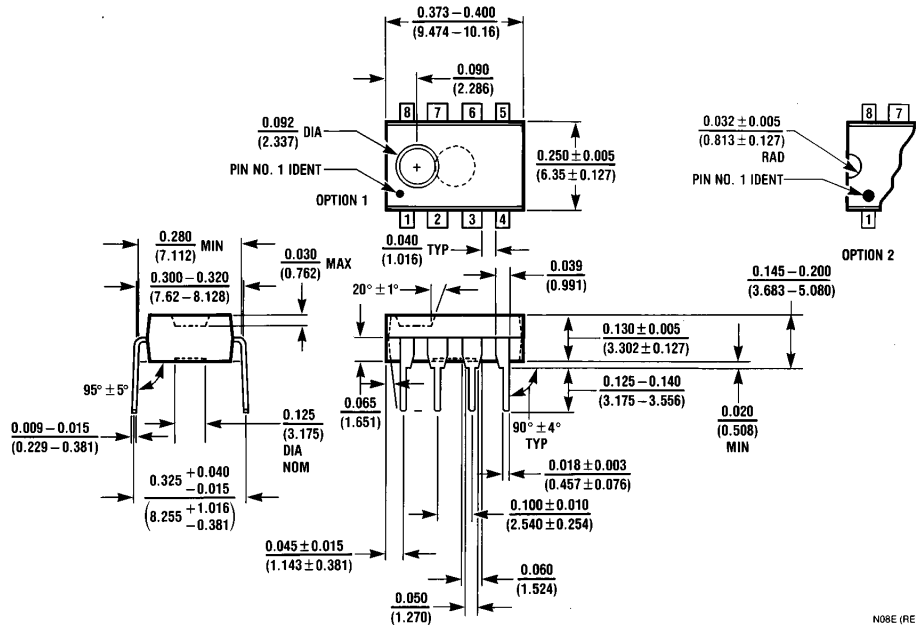

Molded Dual-In-Line Package (N)
Order Number LM1851N
NS Package Number N08E

N08E (REV F)

LIFE SUPPORT POLICY

NATIONAL'S PRODUCTS ARE NOT AUTHORIZED FOR USE AS CRITICAL COMPONENTS IN LIFE SUPPORT DEVICES OR SYSTEMS WITHOUT THE EXPRESS WRITTEN APPROVAL OF THE PRESIDENT OF NATIONAL SEMICONDUCTOR CORPORATION. As used herein:

1. Life support devices or systems are devices or systems which, (a) are intended for surgical implant into the body, or (b) support or sustain life, and whose failure to perform, when properly used in accordance with instructions for use provided in the labeling, can be reasonably expected to result in a significant injury to the user.
2. A critical component is any component of a life support device or system whose failure to perform can be reasonably expected to cause the failure of the life support device or system, or to affect its safety or effectiveness.



National Semiconductor Corporation
 1111 West Bardin Road
 Arlington, TX 76017
 Tel: 1(800) 272-9959
 Fax: 1(800) 737-7018

National Semiconductor Europe
 Fax: (+49) 0-180-530 85 86
 Email: cnjwge@tevm2.nsc.com
 Deutsch Tel: (+49) 0-180-530 85 85
 English Tel: (+49) 0-180-532 78 32
 Français Tel: (+49) 0-180-532 93 58
 Italiano Tel: (+49) 0-180-534 16 80

National Semiconductor Hong Kong Ltd.
 13th Floor, Straight Block,
 Ocean Centre, 5 Canton Rd.
 Tsimshatsui, Kowloon
 Hong Kong
 Tel: (852) 2737-1600
 Fax: (852) 2736-9960

National Semiconductor Japan Ltd.
 Tel: 81-043-299-2309
 Fax: 81-043-299-2408