

## Tuner IC for DAB

### Description

The U2750B-B is a monolithically integrated tuner circuit fabricated with TEMIC Semiconductors' advanced UHF5S technology. Designed for applications in DAB receivers, it includes two selectable mixers, one VCO, a SAW-filter driver, an LO output buffer, a tristate band switch and an AGC-voltage generation block.



Electrostatic sensitive device.  
Observe precautions for handling.



### Features

- 8.5 V supply voltage
- RF frequency range 70 MHz to 260 MHz
- Two identical mixers, selectable by band-switch input
- Balanced mixer input, balanced mixer output (open collector)
- High-impedance mixer inputs
- Four-pin voltage-controlled oscillator
- Balanced LO output for PLL
- SAW-filter driver with low impedance output
- Power measurement and generation of AGC voltage by charge-pump output
- Three charge-pump currents selectable (zero, low, high)
- Voltage regulator for stable operating characteristics

### Block Diagram

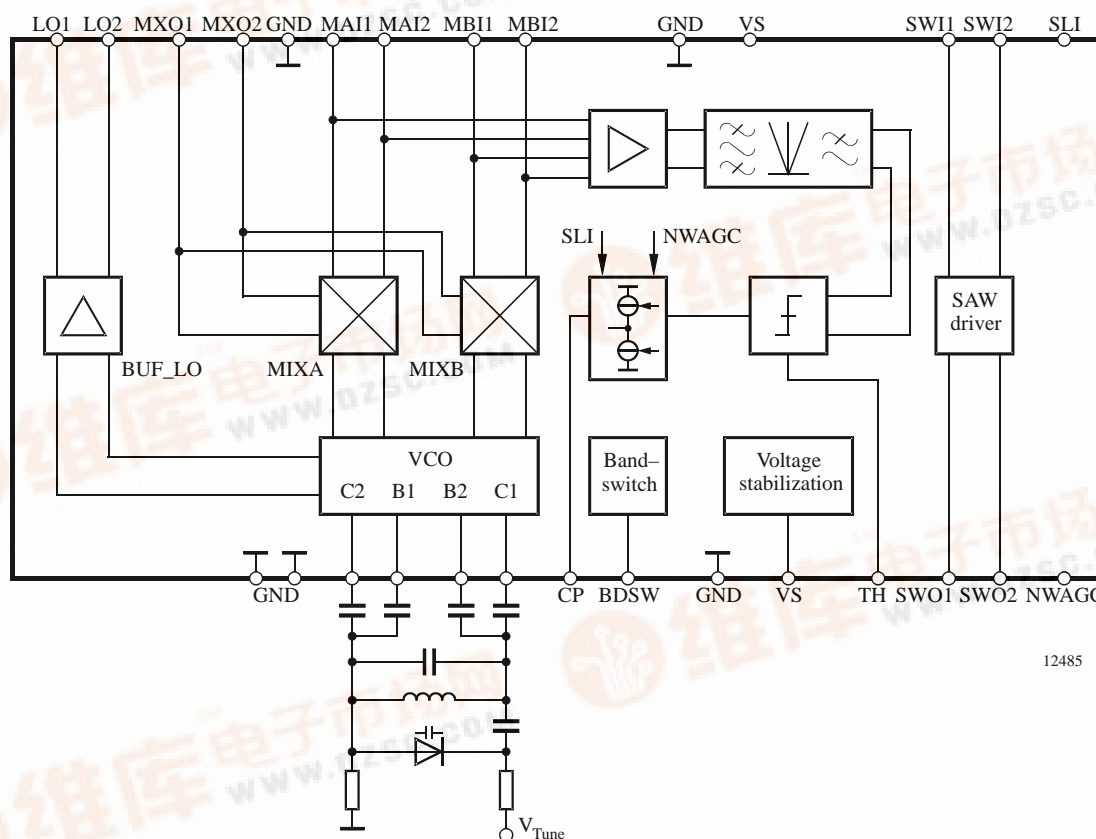

Figure 1. Block diagram



## Ordering Information

Extended Type Number	Package	Remarks
U2750B-BFS	SSO28	

## Pin Description

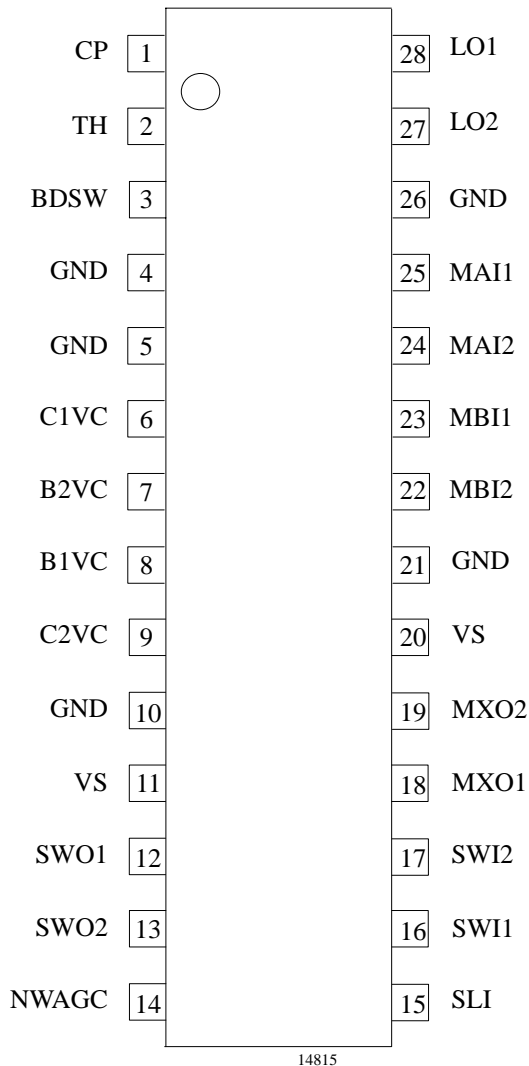

Figure 2. Pinning

Pin	Symbol	Function
1	CP	Charge-pump output of the comparator
2	TH	Threshold input of the comparator
3	BDSW	Band-switch input
4, 5	GND	Ground
6	C1VC	Collector Pin 1 of VCO
7	B2VC	Base Pin 2 of VCO
8	B1VC	Base Pin 1 of VCO
9	C2VC	Collector Pin 2 of VCO
11	VS	Supply voltage
10	GND	Ground
12	SWO1	Differential output of the SAW driver
13	SWO2	Differential output of the SAW driver
14	NWAGC	AGC mode selection
15	SLI	AGC mode selection
16	SWI1	Differential input of the SAW driver
17	SWI2	Differential input of the SAW driver
18	MXO1	Differential mixer output
19	MXO2	Differential mixer output
20	VS	Supply voltage
21	GND	Ground
22	MBI2	Differential input of mixer B
23	MBI1	Differential input of mixer B
24	MAI2	Differential input of mixer A
25	MAI1	Differential input of mixer A
26	GND	Ground
27	LO2	Differential output of LO for PLL
28	LO1	Differential output of LO for PLL

## Functional Description

The U2750B-B represents a tuner IC for applications in DAB receivers. It is intended to be used for reception of band II or band III DAB signals and consists of two mixers, one VCO, a SAW-filter driver, an LO output buffer, a tristate band switch and an AGC-voltage generation circuit as shown in figure 1.

### Mixers and VCO

In order to support two different channels, two identical mixers are integrated. The RF signal is fed to these mixers via the differential input Ports MAI1, MAI2 and MBI1, MBI2. The band-switch input BDSW allows the selection of one of these mixers or to switch off both.

An internal four-pin oscillator (Pins: B1VC, C1VC, B2VC, C2VC) – an equivalent circuit is shown in figure 9 – provides the LO signal to both mixers. Via an LO buffer, the oscillators signal can be accessed at the balanced output Pins LO1, LO2 in order to be fed to a frequency synthesizer circuit (U2753B or U2733B). The result of the mixing process of both mixers appears at the differential open-collector output MXO1, MXO2. In the application shown in figure 7, these mixer output pins are loaded by a resonant load.

### SAW-Filter Driver

The filters' mixer output signal is applied to the differential input Pins SWI1, SWI2 of a SAW-filter driver which amplifies the result of the mixing process and feeds it via its differential output Pins SWO1, SWO2 to an external SAW filter.

### AGC-Voltage Generation Block

The incoming RF signal which appears at the input Pins MAI1, MAI2 or MBI1, MBI2 – depending on the selection made by the Pin BDSW – is amplified, weakly bandpass filtered (transition range: ~ 50 MHz to 300 MHz), rectified and finally lowpass filtered.

The voltage derived in this 'power measurement process' is compared with a voltage threshold which is defined by an external resistor connected to Pin TH, see figure 7. Depending on the result of this comparison, a charge pump feeds a positive or negative current to Pin CP in order to charge or discharge an external capacitor. The voltage of this external capacitor can be used to control the gain of an external (pre-) amplifier stage. By means of the Pins NWAGC and SLI, the current of the charge pump can be selected according to the following table:

NWAGC	SLI	Charge-Pump Current (µA)
LOW	X	off
HIGH	LOW	45 µA (slow mode)
HIGH	HIGH	250 µA (fast mode)

An overview of the functionality of this block can be seen in figure 8.

## Absolute Maximum Ratings

Parameters	Symbol	Min.	Typ.	Max.	Unit
Supply voltage Pins 11 and 20	$V_S$	-0.3		+9.5	V
Junction temperature	$T_j$			125	°C
Storage temperature	$T_{stg}$	-40		+125	°C
External applied voltage at charge-pump output Pin 1	$V_{CP}$	0.4		6.9	V
Band-switch input voltage Pin 3	$V_{BDSW}$	-0.3		+6	V
NWAGC input voltage Pin 14	$V_{NWAGC}$	-0.3		+6	V
SLI input voltage Pin 15	$V_{SLI}$	-0.3		+6	V
Differential input voltage of SAW driver Pins 16 and 17	$V_{SWI}$			300	mV <sub>rms</sub>
Mixer output supply voltage Pins 18 and 19	$V_{MXO}$	6.5		9.5	V
Differential input voltage mixer A,B Pins 22, 23, 24 and 25	$V_{MXI}$			50	mV <sub>rms</sub>

## Thermal Resistance

Parameters	Symbol	Value	Unit
Junction ambient	$R_{thJA}$	130	K/W

## Operating Range

Parameters	Symbol	Min.	Typ.	Max.	Unit
Supply voltage Pins 11 and 20	$V_S$	8.0	8.5	9.35	V
Ambient temperature	$T_{amb}$	-40		+85	°C

## Electrical Characteristics

Test conditions (unless otherwise specified):  $V_S = 8.5$  V,  $T_{amb} = +25$ °C (application circuit see figure 7)

Parameters	Test Conditions / Pins	Symbol	Min.	Typ.	Max.	Unit
<b>Overall characteristics</b>						
Supply voltage	Pins 11 and 20	$V_S$	8.0	8.5	9.35	V
Supply current	Pins 11 and 20	$I_S$	21.6	27	32.4	mA
Voltage gain	MXA, MXB IF/Port <sup>1)</sup>	$G_{V\ tot}$	30	32	34	dB
Noise figure (double side band)	MXA, MXB IF/Port <sup>1)</sup>	$NF_{DSB}$		8		dB
Maximum input level	MXA, MXB Third-order intermodulation distance $\geq 30$ dBc	$P_{in,max}$	-25	-22		dBm
<b>Mixer A, B</b>						
Mixer output current	Pins 18 and 19 Connected to $V_S$	$I_{O,MX}$	2.6	3.3	4.0	mA
Input frequency range	Pins 24, 25, 22 and 23	$f_{in,MX}$	70		260	MHz
Input impedance	Pins 24, 25, 22 and 23 Single ended	$Z_{in,MX}$		2.3    0.9		k $\Omega$ pF

**Electrical Characteristics (continued)**

Test conditions (unless otherwise specified):  $V_S = 8.5\text{ V}$ ,  $T_{\text{amb}} = +25^\circ\text{C}$ , test circuit see figure 7

Parameters	Test Conditions / Pins	Symbol	Min.	Typ.	Max.	Unit
<b>VCO</b>						
Phase noise	$\Delta f = 10\text{ kHz}$ Pins 27 and 28	L(f)		-92		dBc/Hz
		$f_{\text{LO}}$	110		300	MHz
<b>LO buffer</b>						
LO output power	200- $\Omega$ load, differential	$P_{\text{LO}}$	26	34		mV <sub>rms</sub>
LO output impedance	Differential, Pins 27 and 28	$Z_{\text{out,LO}}$		200		$\Omega$
<b>SAW Driver</b>						
Input impedance	Differential, Pins 16 and 17	$Z_{\text{I,SAW}}$		580		$\Omega$
Output impedance	Single ended, Pins 12 and 13	$Z_{\text{OSAW}}$		24		$\Omega$
Voltage gain	Pins 16, 17 $\rightarrow$ Pins 12, 13	$G_{\text{V,SAW}}$		18		dB
<b>AGC Unit</b>						
Internal voltage for threshold adjustment	Without external resistor Pin 2	$V_{\text{TH}}$		1.94		V
Maximum positive charge-pump current, fast mode	$V_{\text{NWAGC}} = \text{HIGH}$ , $V_{\text{SLI}} = \text{HIGH}$ , $P_{\text{RF}} = -30\text{ dBm}$ , $R_{\text{th}} = 12\text{ k}\Omega$ Pin 1	$\text{ICP}_{\text{pos,fm}}$	200	250	300	$\mu\text{A}$
Maximum negative charge-pump current, fast mode	$V_{\text{NWAGC}} = \text{HIGH}$ , $V_{\text{SLI}} = \text{HIGH}$ , $P_{\text{RF}} = -25\text{ dBm}$ , $R_{\text{th}} = 12\text{ k}\Omega$ Pin 1	$\text{ICP}_{\text{neg,fm}}$	-300	-250	-200	$\mu\text{A}$
Maximum positive charge-pump current, slow mode	$V_{\text{NWAGC}} = \text{HIGH}$ , $V_{\text{SLI}} = \text{LOW}$ , $P_{\text{RF}} = -30\text{ dBm}$ , $R_{\text{th}} = 12\text{ k}\Omega$ Pin 1	$\text{ICP}_{\text{pos,sm}}$	35	45	55	$\mu\text{A}$
Maximum negative charge-pump current, slow mode	$V_{\text{NWAGC}} = \text{HIGH}$ , $V_{\text{SLI}} = \text{LOW}$ , $P_{\text{RF}} = -25\text{ dBm}$ , $R_{\text{th}} = 12\text{ k}\Omega$ Pin 1	$\text{ICP}_{\text{neg,sm}}$	-55	-45	-35	$\mu\text{A}$
High-impedance mode charge-pump current	$V_{\text{NWAGC}} = \text{LOW}$ Pin 1	$\text{ICP}_{\text{hi}}$	-50	0	+50	nA
Minimum gain-control voltage	Pin 1	$\text{VAGC}_{\text{min}}$		0.5		V
Maximum gain-control voltage	Pin 1	$\text{VAGC}_{\text{max}}$		6.9		V
Control voltage at NWAGC	NWAGC = HIGH Pin 14	$\text{VNWAGCH}$	3.0			V
Control voltage at NWAGC	NWAGC = LOW Pin 14	$\text{VNWAGCL}$			1.5	V
Control voltage at SLI	SLI = HIGH Pin 15	$\text{VSLI}_{\text{H}}$	3.0			V
Control voltage at SLI	SLI = LOW Pin 15	$\text{VSLI}_{\text{L}}$			1.5	V
<b>Band switch Pin 3</b>						
Band switch	MXA active	$\text{VBDSW}_{\text{A}}$		0	1.0	V
	MXB active	$\text{VBDSW}_{\text{B}}$	4.0	5.0		V
	MXA, MXB inactive	$\text{VBDSW}_{\text{off}}$	2.0		3.0	V

- 1) Ratio of the output voltage at the primary coil of L4 (Pins 12 and 13) to the input voltage (MXA, MXB). Measurement corrected by loss of transformer.

## Typical Operation Characteristics

Operating conditions:  $V_S = 8.5\text{ V}$ ,  $T_{\text{amb}} = 27^\circ\text{C}$ , test conditions see figure 7

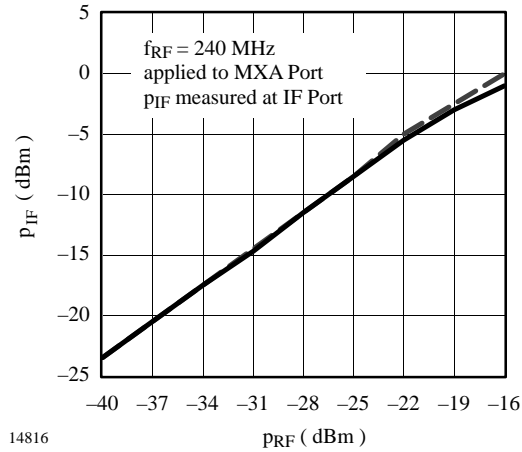

Figure 3. Overall gain

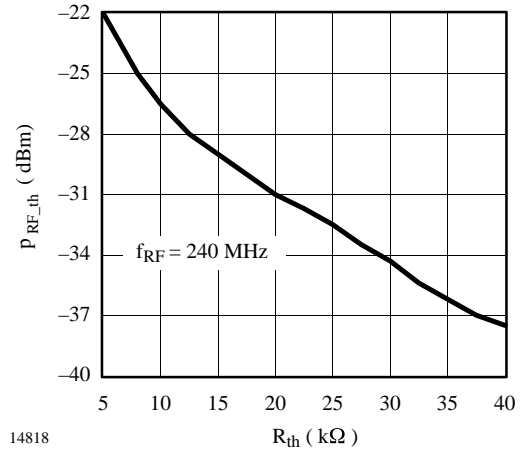

Figure 5. RF power adjustment by  $R_{th}$

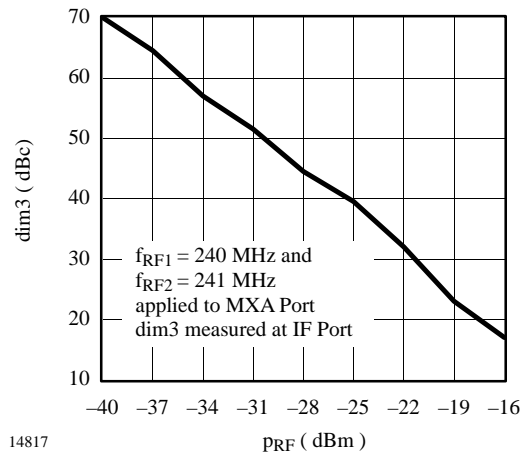

Figure 4. Third-order 2-tone intermodulation ratio

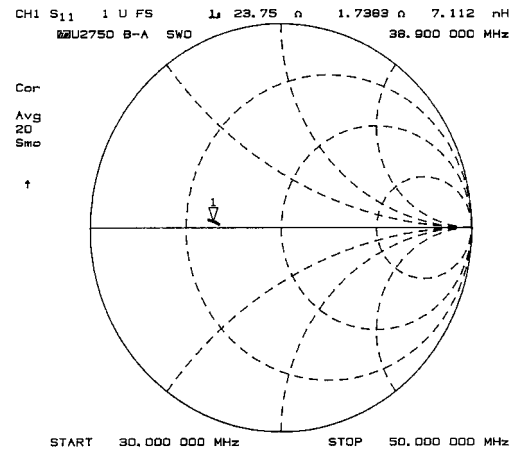

Figure 6. Output impedance SAW-filter driver (Pins 12 and 13 differential)

**Application Circuit ( $f_{IF} = 38.912 \text{ MHz}$ )**

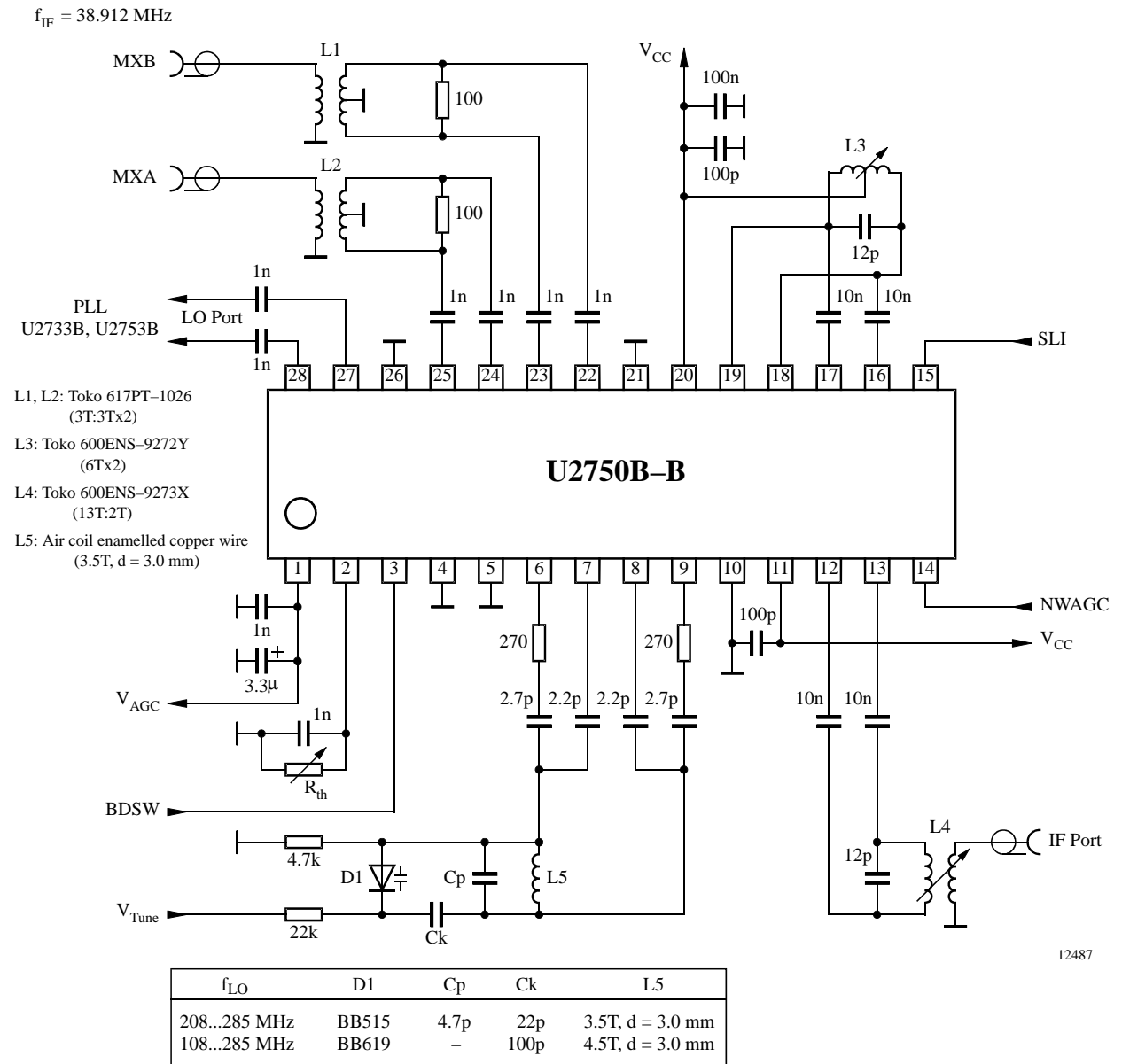

Figure 7. Application circuit

## AGC-Voltage Generation Block Circuit

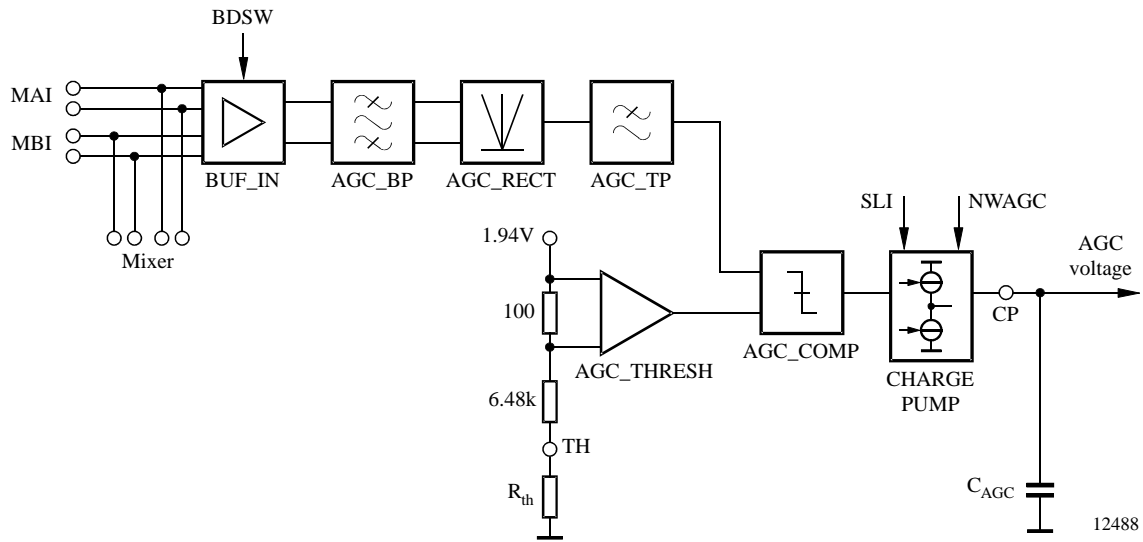

Figure 8. AGC-voltage generation block circuit

## VCO Circuit

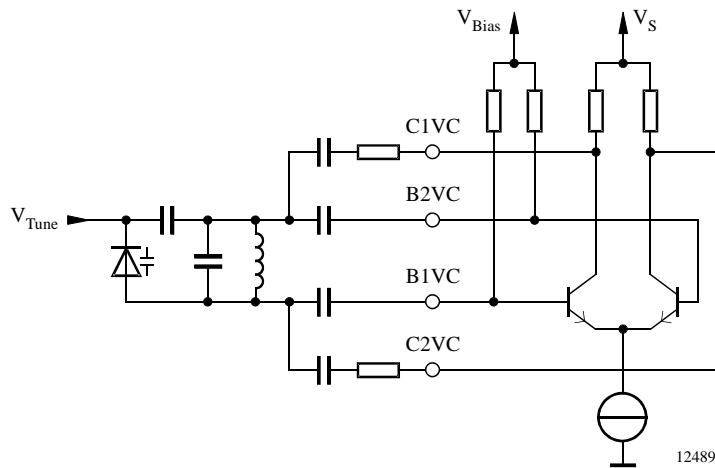

Figure 9. VCO circuit



**Package Information**

Package SSO28

Dimensions in mm

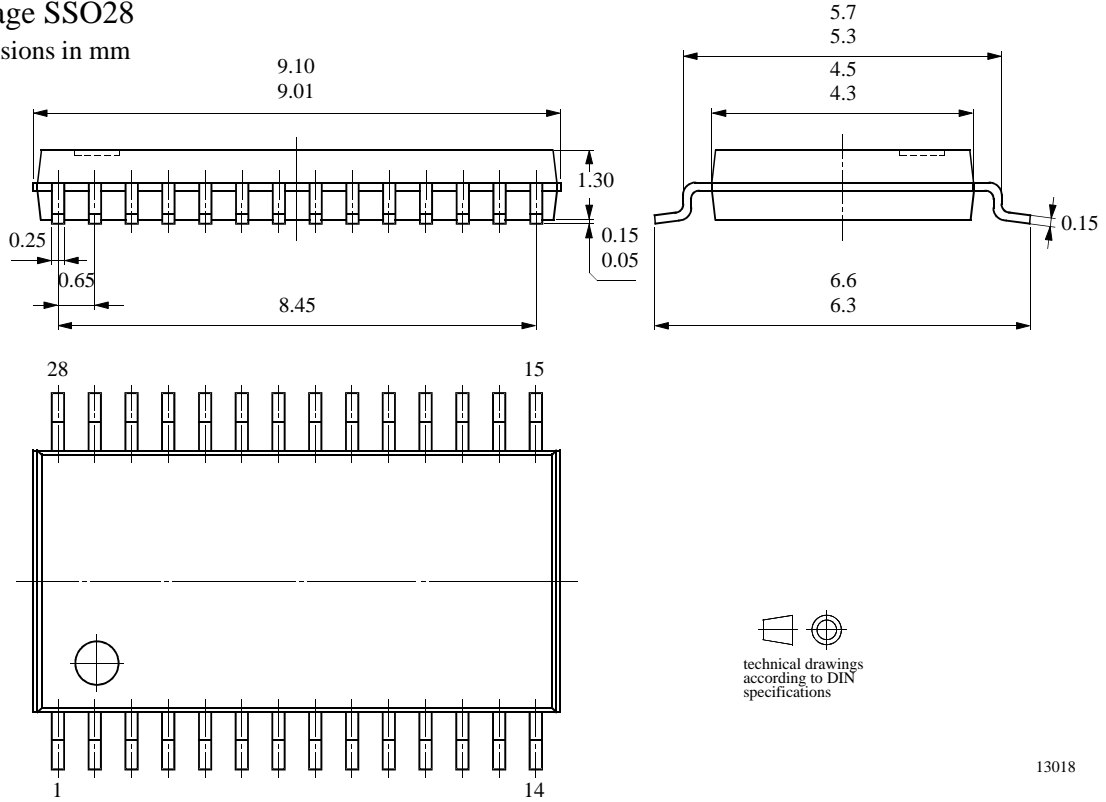

## Ozone Depleting Substances Policy Statement

It is the policy of **TEMIC Semiconductor GmbH** to

1. Meet all present and future national and international statutory requirements.
2. Regularly and continuously improve the performance of our products, processes, distribution and operating systems with respect to their impact on the health and safety of our employees and the public, as well as their impact on the environment.

It is particular concern to control or eliminate releases of those substances into the atmosphere which are known as ozone depleting substances (ODSs).

The Montreal Protocol (1987) and its London Amendments (1990) intend to severely restrict the use of ODSs and forbid their use within the next ten years. Various national and international initiatives are pressing for an earlier ban on these substances.

**TEMIC Semiconductor GmbH** has been able to use its policy of continuous improvements to eliminate the use of ODSs listed in the following documents.

1. Annex A, B and list of transitional substances of the Montreal Protocol and the London Amendments respectively
2. Class I and II ozone depleting substances in the Clean Air Act Amendments of 1990 by the Environmental Protection Agency (EPA) in the USA
3. Council Decision 88/540/EEC and 91/690/EEC Annex A, B and C (transitional substances) respectively.

**TEMIC Semiconductor GmbH** can certify that our semiconductors are not manufactured with ozone depleting substances and do not contain such substances.

**We reserve the right to make changes to improve technical design and may do so without further notice.**

Parameters can vary in different applications. All operating parameters must be validated for each customer application by the customer. Should the buyer use TEMIC Semiconductors products for any unintended or unauthorized application, the buyer shall indemnify TEMIC Semiconductors against all claims, costs, damages, and expenses, arising out of, directly or indirectly, any claim of personal damage, injury or death associated with such unintended or unauthorized use.

TEMIC Semiconductor GmbH, P.O.B. 3535, D-74025 Heilbronn, Germany  
Telephone: 49 (0)7131 67 2594, Fax number: 49 (0)7131 67 2423