

Telephone Speech Circuit

Description

The U4030B is an electronic speech circuit for standard and feature telephones. It replaces the hybrid transformer, earphone and microphone interface and the supply voltage generation for external components, e.g. dialer or microcomputers. Using the U4030B in telephone circuit

designs can improve transmission quality and results in cost savings through shorter and more flexible design procedures. It reduces the amount of external components needed. The U4030B uses TEMIC's reliable bipolar technology and is offered in a SO20 package.

Features

- Microphone amplifier with
 - Symmetrical input
 - Privacy function
 - Anticlippping
- Built in ear protection
- Power down input
- Mute input
- DTMF interface
- Low line impedance during pulse dialing

Benefits

- Independent adjustment of
 - Transmission gain
 - Receiving gain
 - Sidetone suppression
 - Frequency response
- Low-impedance supply voltage for all external blocks
- Supply voltage for an electret microphone

Applications

- Standard telephone
- Fax machine
- Answering machine
- Cordless telephone

Block Diagram

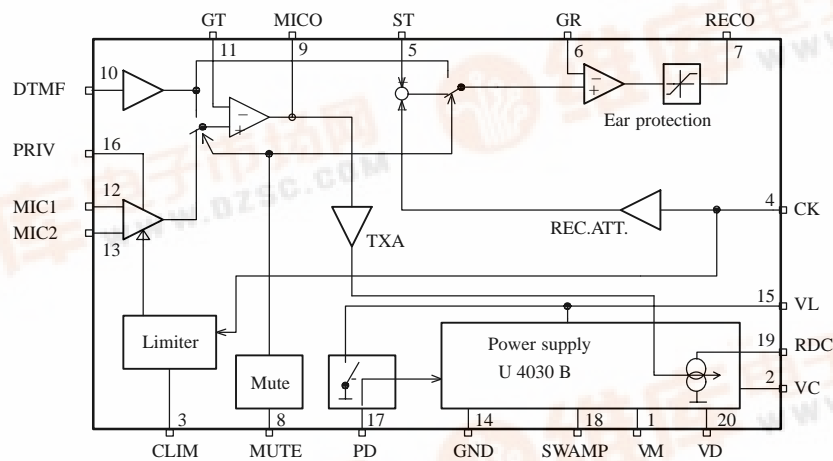
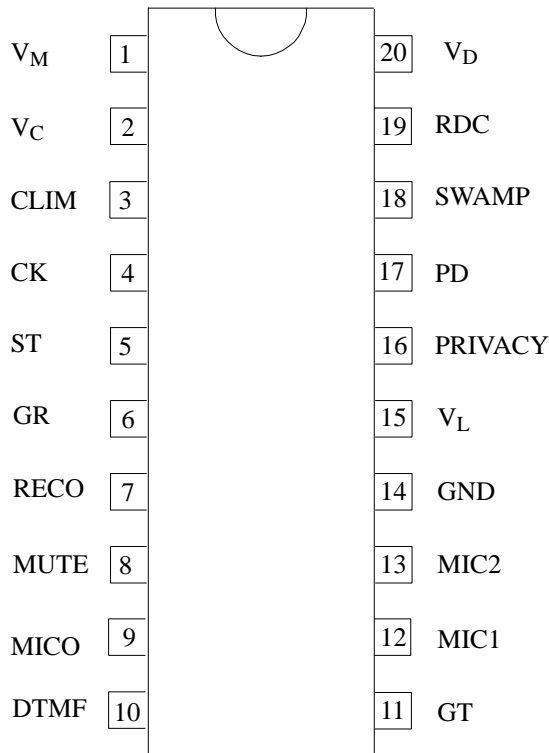

Figure 1.

Ordering Information

Extended Type Number	Package	Remarks
U4030B-A	DIP20	Tube
U4030B-AFL	SO20	Tube
U4030B-AFLG3	SO20	Taped and reeled

Pin Description



10	DTMF	Input for DTMF signals (AC-coupled). In mute condition a small portion of the signal at this pin is monitored to the receive output
11	GT	Input for transmit gain control
12	MIC1	Inverting input of microphone amplifier
13	MIC2	Non-inverting input of microphone amplifier
14	GND	Ground (reference point for DC and AC signals)
15	V_L	Line voltage
16	PRIVACY	Active high input to disable microphone amplifier
17	PD	Power down input. Active high input for reducing the current consumption of the circuit. Simultaneously V_L is shorted by an internal switch
18	SWAMP	A resistor connected from this point to ground converts the excess line current into heat in order to prevent the IC from thermal destruction at high line currents
19	RDC	Input of power supply
20	V_D	Unregulated supply voltage for peripheral circuits. Output current capability and output voltage increase with line current

Pin	Symbol	Function
1	V_M	Supply voltage for an electret microphone, virtual ground
2	V_C	The internal inductance of the circuit is proportional to the value of the capacitor at this pin. A resistor connected to ground may be used to reduce the line voltage
3	CLIM	Time constant of anticlipping in trans. path
4	CK	Input of receive amplifier
5	ST	Input of sidetone amplifier, must be DC-coupled to V_M
6	G_R	Input for receive gain control
7	RECO	Output of receiving amplifier
8	MUTE	Active high input to switch circuit in DTMF-condition
9	MICO	Output of microphone amplifier
Pin	Symbol	Function

Circuit Description

Reference for all descriptions is figure 9, unless otherwise specified.

Power Supply

DC characteristic

The power supply stage determines the voltage/ current characteristic of the circuit. The DC-slope is adjusted to 100 Ω. A resistor connected from Pin 2 to Pin 14 may be used to reduce the line voltage (figure 2).

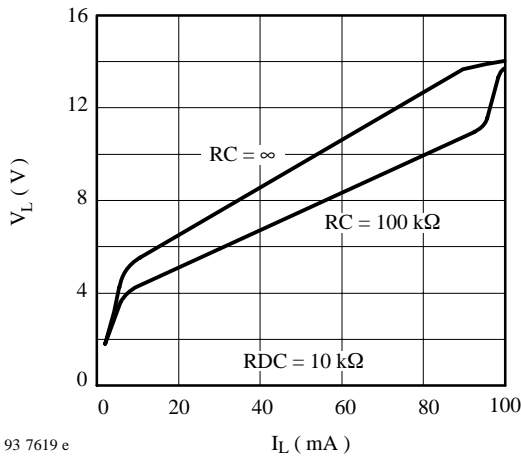

Figure 2. DC characteristics

$$V_L = (0.0033 \times I_{DC} + I_{OFFSET}) \times (R30 || RC) + VRS + IRDC \times RDC$$

with:

- $I_{OFFSET} = 150 \mu A$
- $VRS = 150 mV$
- $R30 = 30 k\Omega$
- $IDC = I_L - (750 \mu A + 0.023 \times I_L)$

V_D

An unregulated voltage, V_D, is generated to supply the internal and external circuits. The maximum voltage at this pin is limited by an internal Z-diode to a value of 6.2 V. The available output current is shown in figure 3.

V_M

The supply voltage for an electret microphone is derived from V_D (see figure 4). The output resistance is set to

300 Ω and the maximum output current is 300 μA. The V_M-pin is virtual ground for the receiving amplifier.

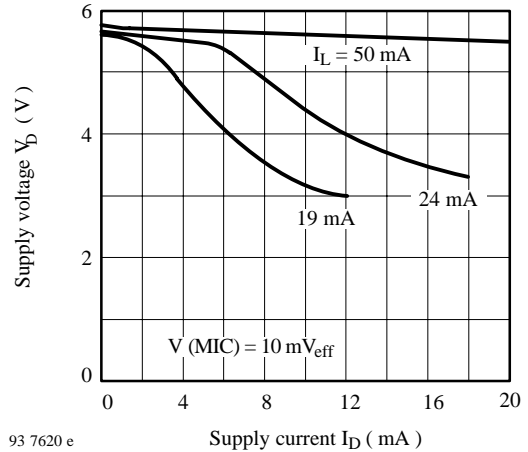

Figure 3. Supply voltage, V_D

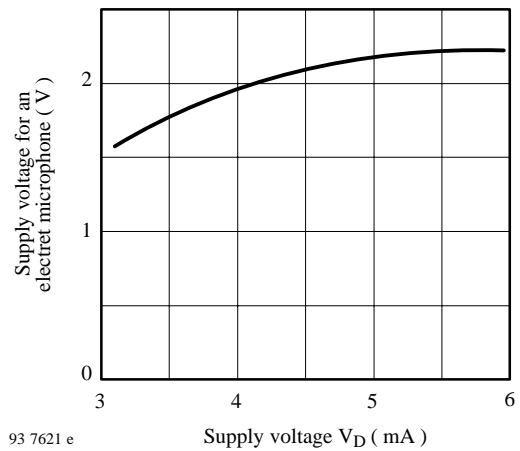

Figure 4. Electret microphone supply, V_M

Swamp

Line current which is not used for internal and external circuits is converted into heat via resistance R_{swamp} in order to prevent the IC from thermal destruction at high line currents.

The speech circuit will be high ohmic when the voltage at SWAMP reaches 6 V. Typical characteristics for various resistors are shown in figure 5.

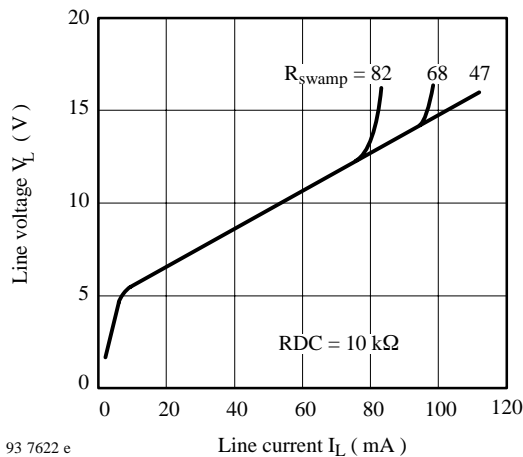

Figure 5. Typical DC characteristics for various SWAMP resistors

Charge Up Circuit

By OFF HOOK the handset, an integrated charge up circuit provides V_D with the whole line current. When V_D reaches 2.2 V, the charge up circuit is automatically switched off.

The specifications for the German "Deutsche Telekom" (speech readiness, start time) will be fulfilled even with 1000 μF at Pin 20.

Figure 6 illustrates the transient behavior of the circuit at $I_L = 20 \text{ mA}$.

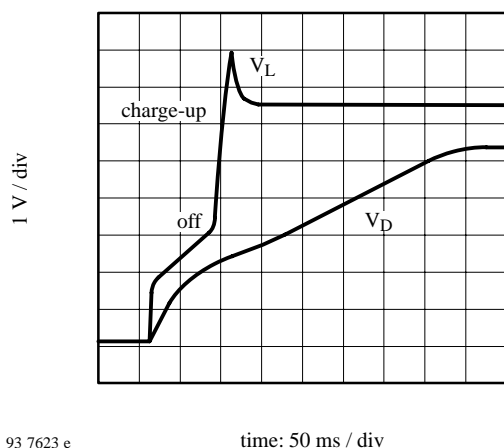

Figure 6. Charge up characteristics at $I_L = 20 \text{ mA}$

Electronic Inductance

The AC resistance ($R_{\text{imp}} 1 \text{ k}\Omega$) of the telephone should be much higher than the DC resistance (325Ω), the latter being decoupled via an electronic inductance.

The value of L is given by:

$$L = \text{CVC} \times \text{RDC} \times 30 \text{ k}\Omega \parallel R$$

where

$$\begin{aligned} \text{RDC} &= 10 \Omega \\ \text{CVC} &= 10 \mu\text{F} \\ \text{R30} &= 30 \text{ k}\Omega \\ \text{RC} &= \text{infinite} \\ L &= 3 \text{ H} \end{aligned}$$

Transmit

Microphone amplifier

The microphone amplifier of U4030B has symmetrical inputs (MIC1 and MIC2) with an input resistance of 60 $\text{k}\Omega$ (typical). It has a gain of 29 dB which is adjustable with resistances RS1 and RS2 as follows:

$$\begin{aligned} G_T &= V_{\text{MICO}} / V_{(\text{MIC1}, \text{MIC2})} \\ &= 20 \log[(RS1 / RS2) + 1] \text{ dB} \end{aligned}$$

A low pass function can be realised with CSLP. The corner frequency is given by:

$$f_C = 1 / (2\pi RS1 \text{ CSLP})$$

When the AC level on V_L is very high, the amplification of the microphone is reduced by the limiter function. The threshold of the limiter is fixed at 5.5 dBm (typical).

DTMF

The amplification of the DTMF signal is determined by the ratio of RS1 and RS2 as follows:

$$\begin{aligned} G_D &= V_{\text{MICO}} / V_{\text{DTMF}} \\ &= 20 \log\{0.19 \times [(RS1 / RS2) + 1]\} \end{aligned}$$

An external voltage divider is used to adjust the proper DTMF level at line.

For monitoring the dialing procedure, an attenuated DTMF signal is sent to the earpiece. The Deutsche Telekom specification is fulfilled with the nominal value of the transmit and receive gain.

Transmit Output Amplifier

The output signal of the microphone and DTMF preamplifier is internally coupled to a second amplifier (TXA) which is used to modulate a controlled current source. Assuming a termination of 600 Ω at a line, the gain from MICO to V_L is typically 15.6 dB.

Receive Amplifier

The receive signal is taken from line via capacitor C_{CK}. A resistive attenuator (-32 dB) sets the appropriate input level for the following output amplifier. The input impedance at Pin 4 is typically 80 kΩ.

Voltage gain is:

$$\begin{aligned} G_R &= 20 \log (V_{\text{ear}} / V_L) \text{ dB} \\ &= -32 \text{ dB} + 20 \log[(RR1 / RR2) + 1] \text{ dB} \\ &= +1.8 \text{ dB} \end{aligned}$$

The adjustment range for receive gain G_R is typically -4 dB to +8 dB.

The built-in ear protection limits the output swing at Pin 7 to 2.4 V_{pp} (V_D > 4 V). For high receive gain, the maximum undistorted output level might not be sufficient due to clipping by ear protection.

Sidetone

The amplified microphone signal is available at the input of the sidetone loop, MICO. The loop consists of a transmit amplifier (transconductance STX), the impedance at line, receive attenuator (gain) and the sidetone network (figure 7).

The sidetone cancellation is achieved by comparing a part of the line signal with the output of the sidetone network (V_{ST}→V_R). Assuming a real impedance of the telephone (R_{TEL}) the optimum sidetone network can be calculated:

$$\begin{aligned} a &= (S_{TX} \times R_{APP} \times G) / (1 - S_{TX} \times R_{APP} \times G) \\ Z_{NW} &= S_{TX} \times R \times G \times Z_{Line} \end{aligned}$$

Adjustment to the sensitivities of the handset can be done independently from the sidetone network because receive and transmit gain are set outside of the sidetone loop.

Power Down (PD)

The speech circuit is switched low ohmic by selecting a high level at PD during the pulse dialling. The voltage drop across the IC will be typically 1.5 V. During this time the capacitor C_{VD} will not be discharged, because an internal power down switches off all internal amplifiers. In order to avoid cracks, it is recommended to activate power down while sending the dial pulses (figure 8).

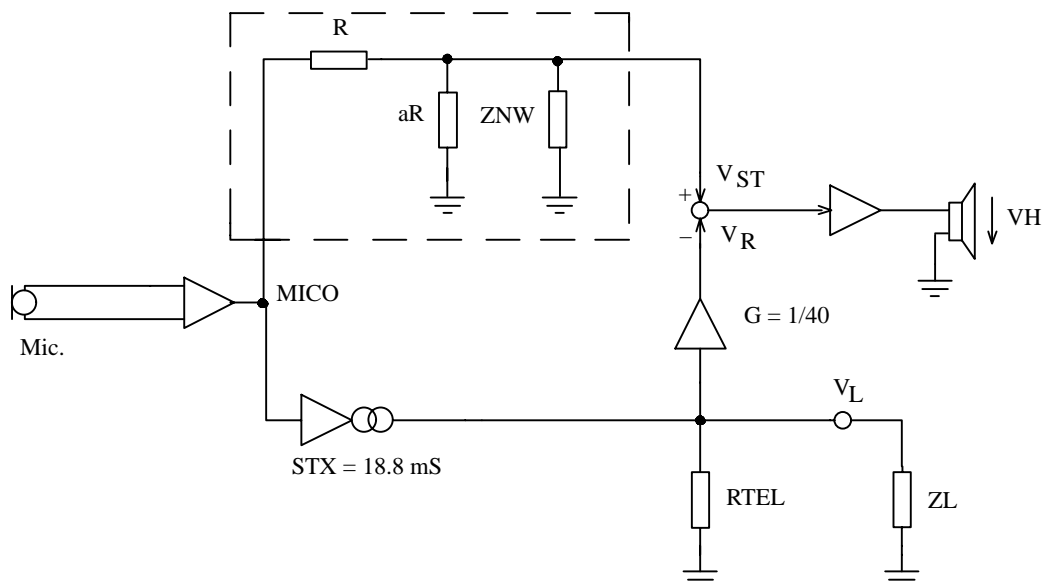

93 7624 e

Figure 7. Schematic of the sidetone

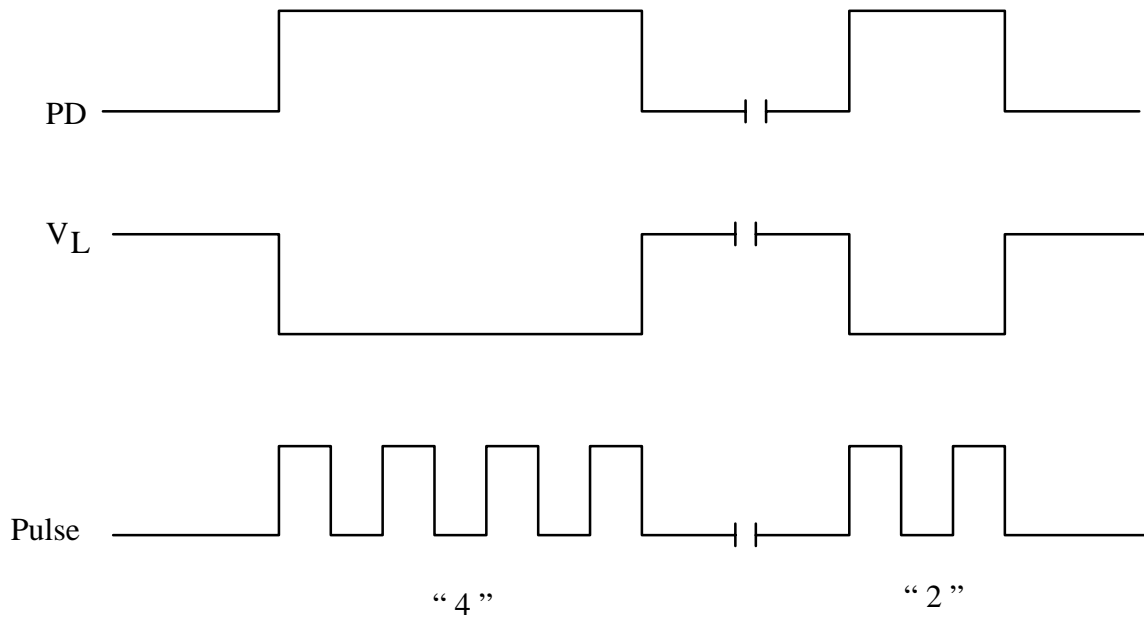

93 7625 e

Figure 8. Recommended timing diagram for power down diagram

Absolute Maximum Ratings

Parameters	Symbol	Value	Unit
Line current (according to figure11)	I_L	200	mA
DC line voltage	V_L	16	V
Storage temperature range	T_{stg}	-55 to +150	°C
Junction temperature	T_j	150	°C
Ambient temperature range	T_{amb}	-25 to +65	°C
Power dissipation, $T_{amb} = 60^\circ\text{C}$	DIP20	P_{tot}	820 mW
	SO20	P_{tot}	640 mW

Thermal Resistance

Parameters	Symbol	Value	Unit
Junction ambient	DIP20	R_{thJA}	110 K/W
	SO20	R_{thJA}	140 K/W

Electrical Characteristics

f = 1000 Hz, T_{amb} = 25°C, reference point Pin 14, unless otherwise specified

Parameters	Test Conditions / Pins	Symbol	Min.	Typ.	Max.	Unit
DC characteristics (figure 11)						
DC voltage in speech mode	I _L = 19 mA	V _L	6.2	6.5	6.8	V
	I _L = 26 mA			7.2		V
	I _L = 60 mA		10.0	10.5	11.0	V
Transmit amplifier and sidetone reduction (figure 12)						
Input resistance		R _I	45.0	60.0	80.0	kΩ
Transmit gain	I _L = 24 mA	G _T	44.2	44.7	45.2	dB
Gain variation	19 mA ≤ I _L ≤ 60 mA	ΔG _T	-0.5		+0.5	dB
Noise at line, psophometrically weighted	R _L = 600 Ω Z _{RECO} = 68 nF Z _{MIC} = 68 nF I _L = 19 to 60 mA	n _O			-75.0	dBmp
Sidetone gain (figure 12)		G _{ST}		33.5		dB
Max. output voltage	R _L → ∞ d ≤ 5% V _{MIC} = 5.4 mV	V _{Omax}		5.5	6.3	dBm
Common mode rejection ratio		CMRR		80.0		dB
Mute: reduction of voltage amplification	Z _{RECO} = 68 nF		60.0			dB
Privacy: reduction of voltage amplification			60.0			dB
Receiving amplifier (figure 13)						
Gain	Z _{RECO} = 68 nF I _L = 24 mA	G _R	-3.9	-3.4	-2.9	dB
Gain variation	19 mA ≤ I _L ≤ 60 mA	ΔG _R	-0.5		0.5	dB
Noise at earphone psophometrically weighted	I _L = 19 to 60 mA Load T, R = 600 Ω Z _{RECO} = 68 nF Z _{MIC} = 68 nF	n _I			-78	dBmp
Max. output voltage	I _L = 19 to 60 mA Z _{RECO} = 68 nF d ≤ 2%	V _{Omax}	600	650		mVrms
Switching threshold of ear protection	I _L = 19 to 60 mA Z _{RECO} = 68 nF V _{GEN} = 3 Vrms		0.7		1.3	Vrms
Voltage amp. from DTMF to RECO	Z _{ear} = 68 nF		-7	-4	-1	dB
Output impedance					10	Ω
Power down (figure 14)						
PD-off input voltage		V _I			0.3	V
PD-on input voltage		V _I	2			V
Input current	V _I = 6 V	I _I			130	μA
Line voltage	PD on, I _L = 24 mA	V _L		1.5		V
Input current consumption at V _D	PD on	I _D			100	μA

Parameters	Test Conditions / Pins	Symbol	Min.	Typ.	Max.	Unit
Mute input, (figure 14)						
MUTE input current	$V_{MUTE} = 6\text{ V}$ $V_{MUTE} = 0.3\text{ V}$	I_{MUTE}			120 -25	μA μA
MUTE-off input voltage		V_{MUTE}			0.3	V
MUTE-on input voltage		V_{MUTE}	1.5			V
Supply voltages (figure 12)						
Output voltage	$I_L = 19\text{ mA}$ $I_D = 4.5\text{ mA}$ $V_{MIC} = 10\text{ mV}$ $I_L = 50\text{ mA}$ $I_D = 15\text{ mA}$ $V_{MIC} = 10\text{ mV}$	V_D	4.0	4.5		V
			5.5		6.2	V
Output voltage	$I_L = 19\text{ mA}$ $I_D = 3\text{ mA}$ $I_M = 300\text{ }\mu\text{A}$	V_M		2.2		V
Output current		I_M			300	μA
Output resistance		R_O		300		Ω
DTMF-amplifier (figure 14)						
Input resistance		R_D	22	31	37	k Ω
DTMF-gain	Load = Z_R $0 < R_v < 1530\text{ }\Omega$	G_D	24.7	26	27	dB
Max. output voltage	$I_L = 19\text{ to }60\text{ mA}$ Load = Z_R $d \leq 2\%$		1.8			V_{rms}
Privacy (figure 14)						
PRIV-on input voltage		V_{PRIV}	2			V
PRIV-off input voltage		V_{PRIV}			0.8	V
Input current	$V_{PRIV} = 6\text{ V}$	I_{PRIV}			60	μA

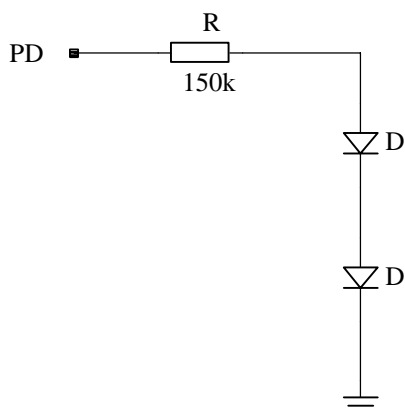

Figure 9. PD input

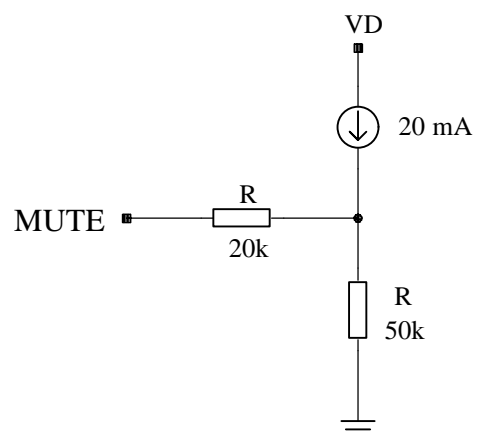
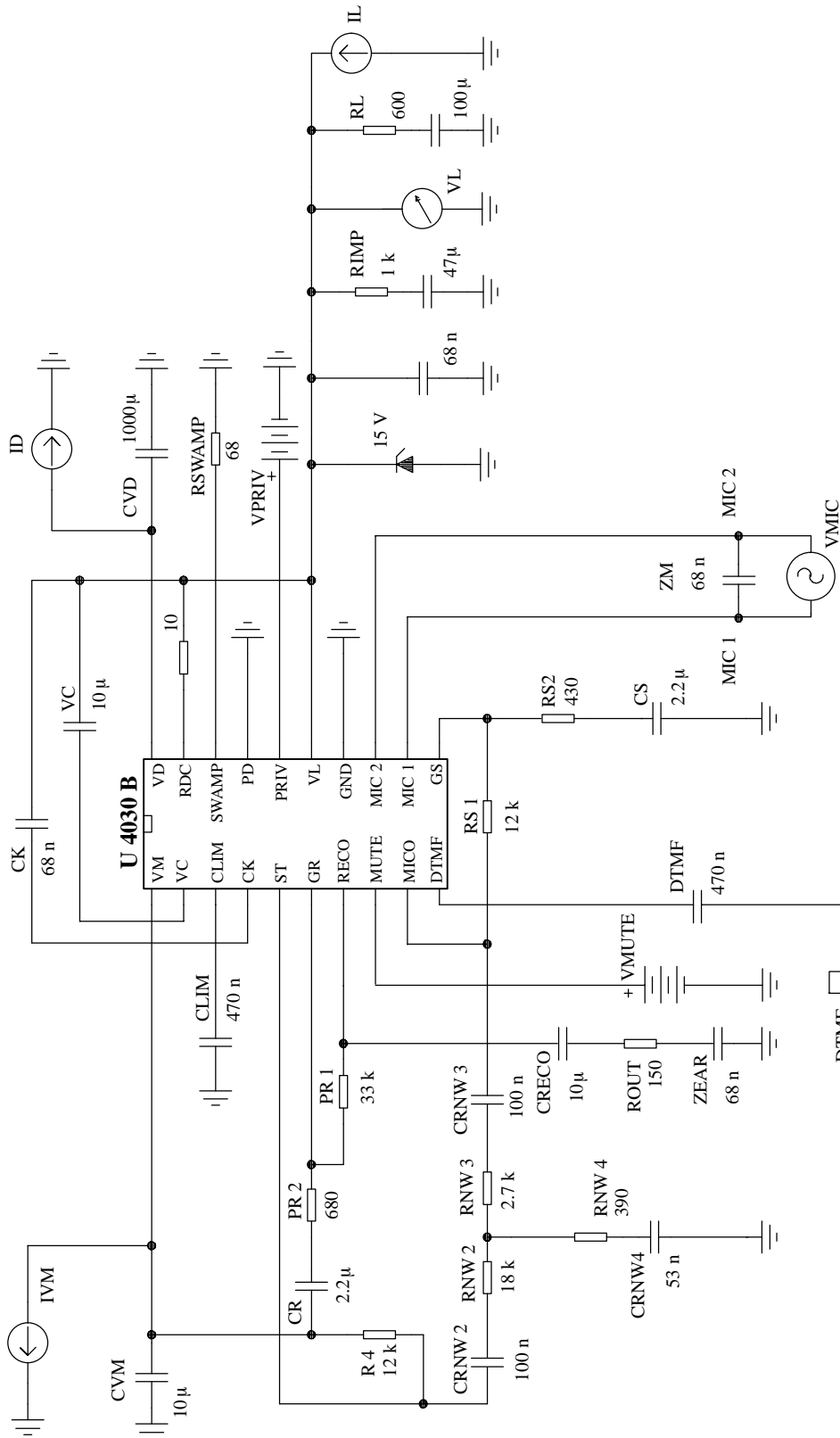

Figure 10. Mute input

93 7630 e



93 7627 e

Figure 12. Transmit gain

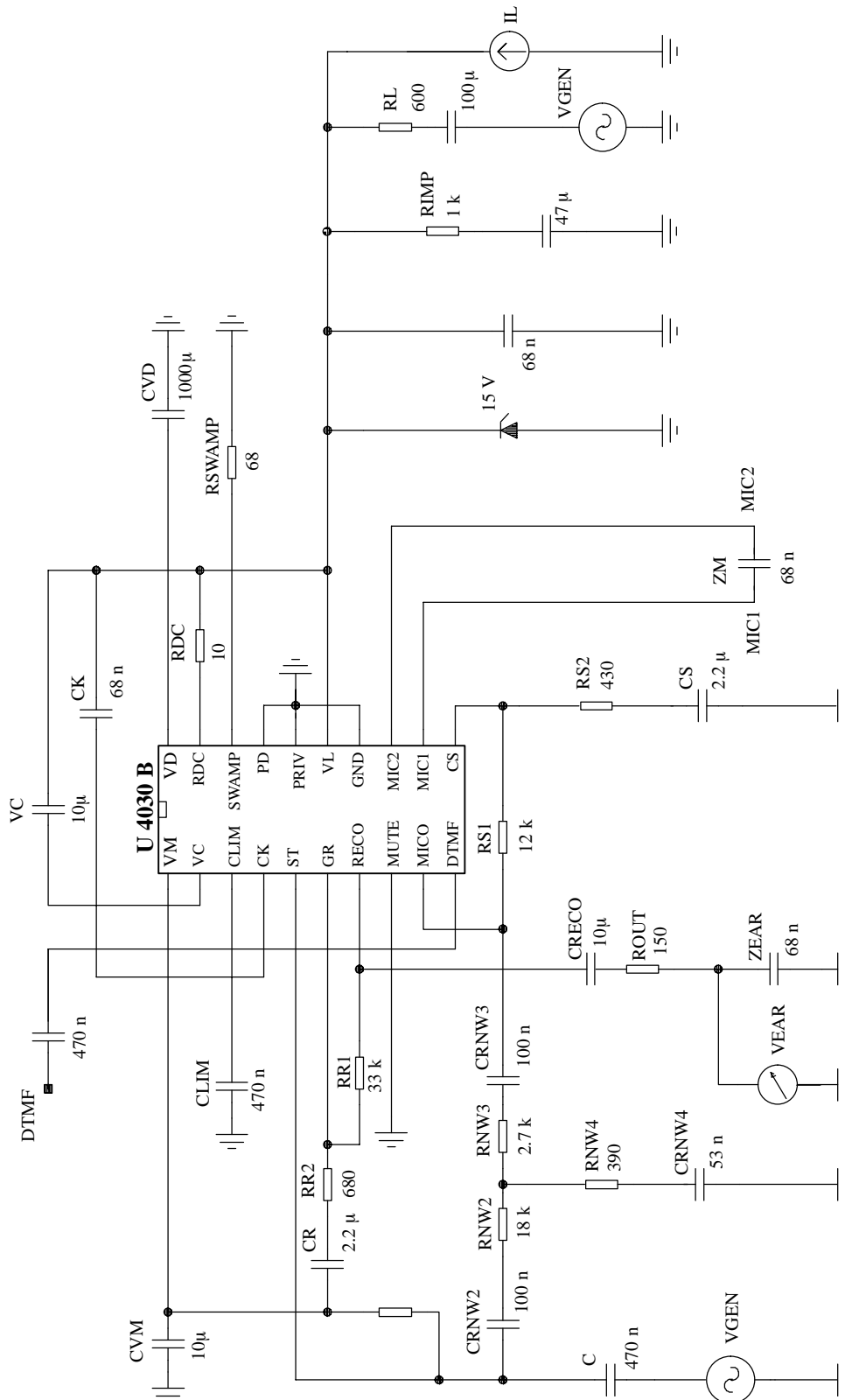

93 7628 e

Figure 13. Receiving gain and sidetone amplification

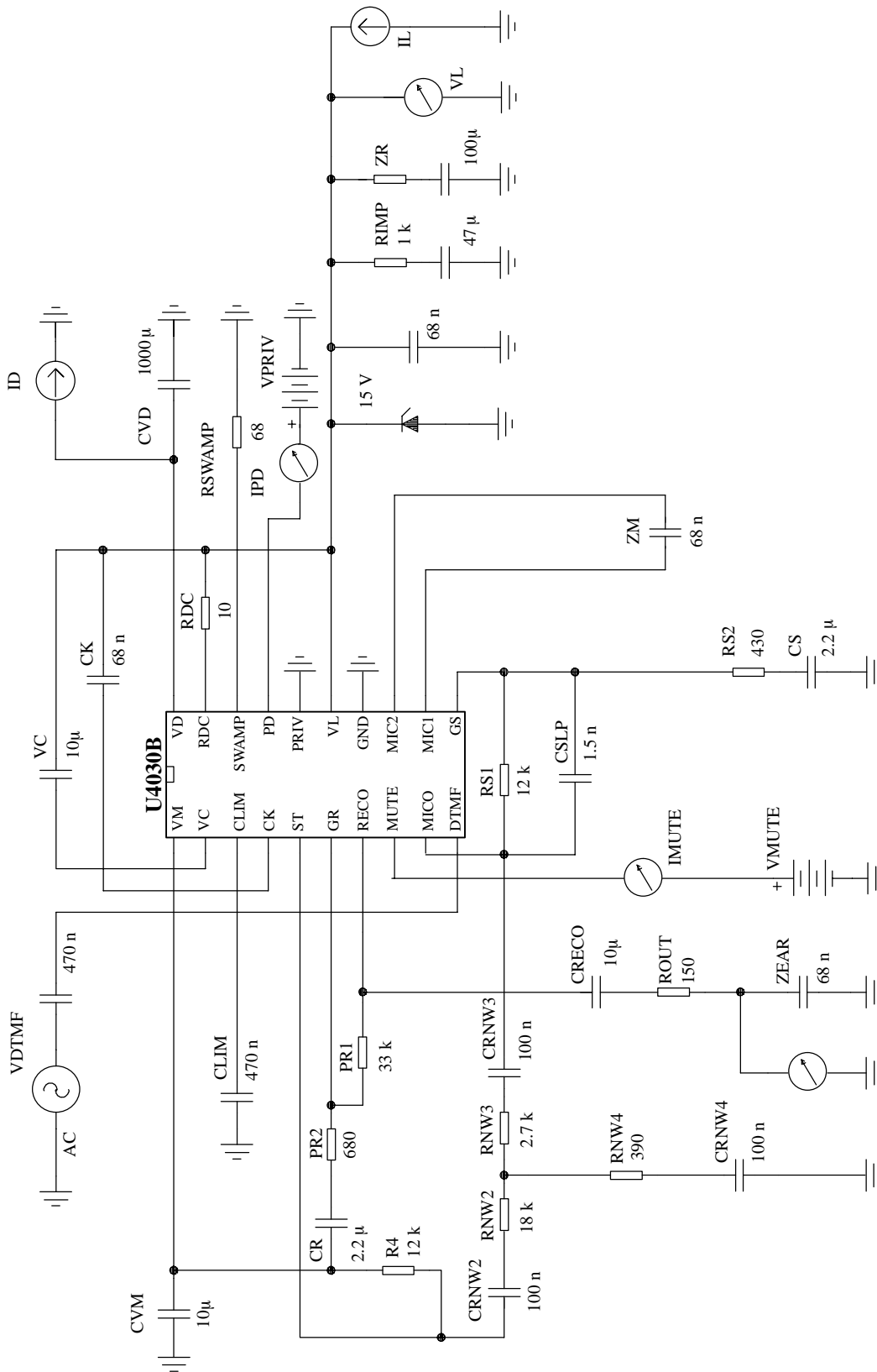

93 7629 e

Figure 14. DTMF gain

Package Information

Package DIP20 (CEI)

Dimensions in mm

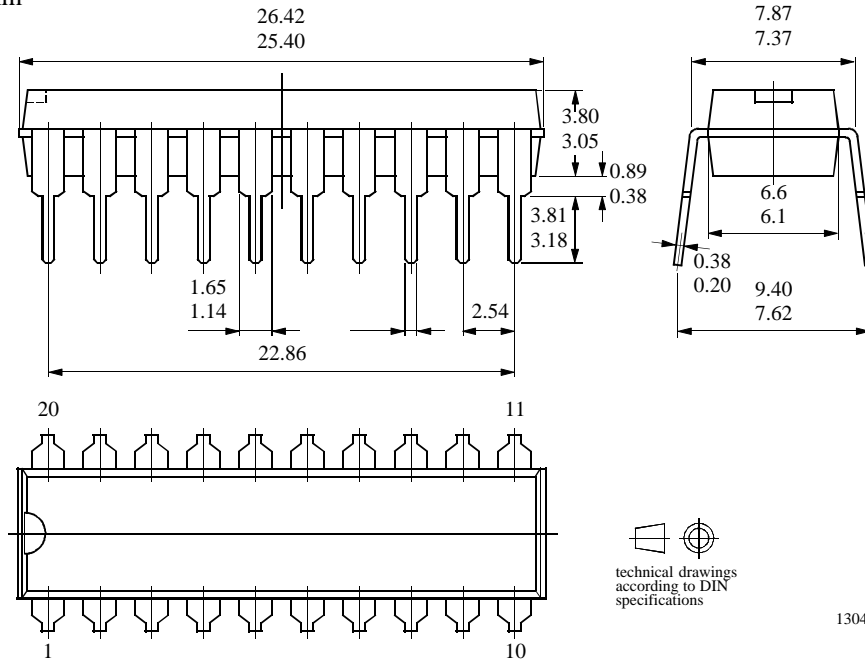

Package SO20

Dimensions in mm

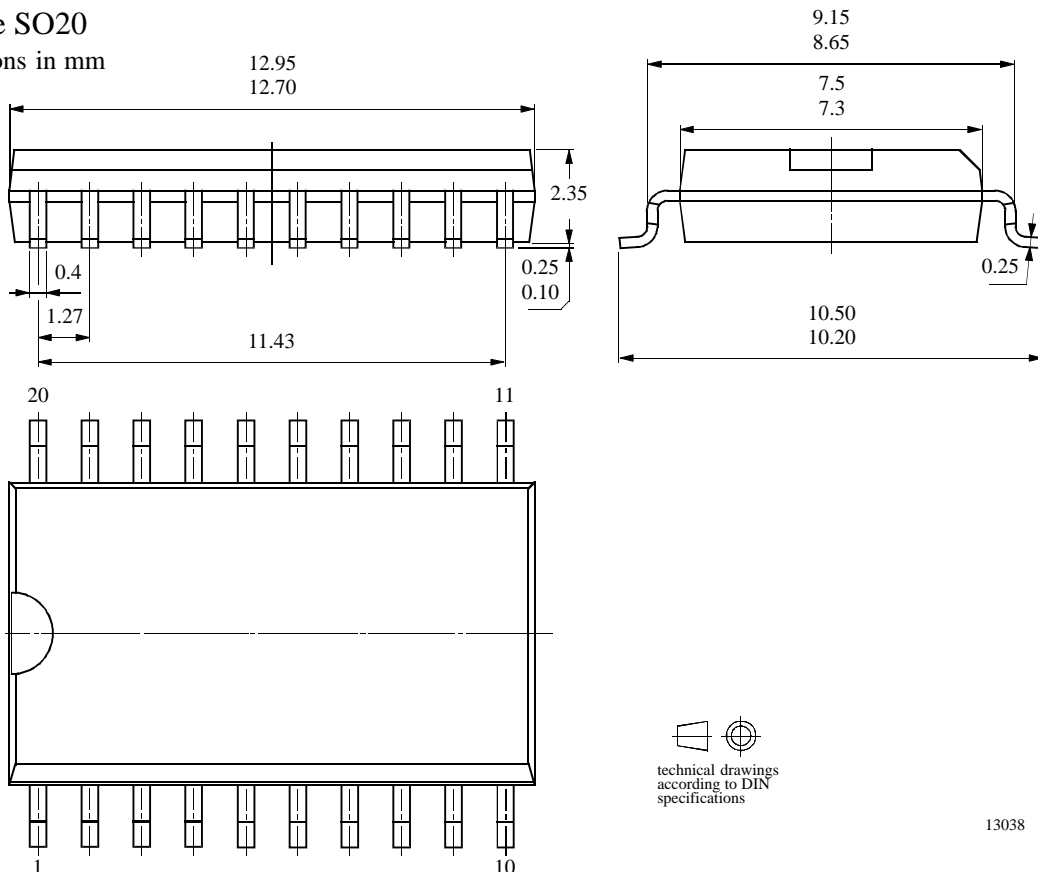

Ozone Depleting Substances Policy Statement

It is the policy of **TEMIC Semiconductor GmbH** to

1. Meet all present and future national and international statutory requirements.
2. Regularly and continuously improve the performance of our products, processes, distribution and operating systems with respect to their impact on the health and safety of our employees and the public, as well as their impact on the environment.

It is particular concern to control or eliminate releases of those substances into the atmosphere which are known as ozone depleting substances (ODSs).

The Montreal Protocol (1987) and its London Amendments (1990) intend to severely restrict the use of ODSs and forbid their use within the next ten years. Various national and international initiatives are pressing for an earlier ban on these substances.

TEMIC Semiconductor GmbH has been able to use its policy of continuous improvements to eliminate the use of ODSs listed in the following documents.

1. Annex A, B and list of transitional substances of the Montreal Protocol and the London Amendments respectively
2. Class I and II ozone depleting substances in the Clean Air Act Amendments of 1990 by the Environmental Protection Agency (EPA) in the USA
3. Council Decision 88/540/EEC and 91/690/EEC Annex A, B and C (transitional substances) respectively.

TEMIC Semiconductor GmbH can certify that our semiconductors are not manufactured with ozone depleting substances and do not contain such substances.

We reserve the right to make changes to improve technical design and may do so without further notice.

Parameters can vary in different applications. All operating parameters must be validated for each customer application by the customer. Should the buyer use TEMIC products for any unintended or unauthorized application, the buyer shall indemnify TEMIC against all claims, costs, damages, and expenses, arising out of, directly or indirectly, any claim of personal damage, injury or death associated with such unintended or unauthorized use.

TEMIC Semiconductor GmbH, P.O.B. 3535, D-74025 Heilbronn, Germany
Telephone: 49 (0)7131 67 2831, Fax number: 49 (0)7131 67 2423