



# LT1137A

## Advanced Low Power 5V RS232 Transceiver with Small Capacitors

### FEATURES

- ESD Protection over  $\pm 10\text{kV}$
- Uses Small Capacitors:  $0.1\mu\text{F}$ ,  $0.2\mu\text{F}$
- $1\mu\text{A}$  Supply Current in SHUTDOWN
- Pin Compatible with LT1137
- Operates to 120k Baud
- CMOS Comparable Low Power: 60mW
- Operates from a Single 5V Supply
- Easy PC Layout: Flowthrough Architecture
- Rugged Bipolar Design
- Outputs Assume a High Impedance State When Off or Powered Down
- Improved Protection: RS232 I/O Lines Can Be Forced to  $\pm 30\text{V}$  without Damage
- Output Overvoltage Does Not Force Current Back into Supplies
- Absolutely No Latch-up
- Available in SO Package

### APPLICATIONS

- Notebook Computers
- Palmtop Computers

### DESCRIPTION

The LT1137A is a three-driver, five-receiver RS232 transceiver, pin compatible with the LT1137, offering performance improvements and two SHUTDOWN modes. The LT1137A's charge pump is designed for extended compliance, and can deliver over 40mA of load current. Supply current is typically 12mA, competitive with similar CMOS devices. An advanced driver output stage operates up to 120k baud while driving heavy capacitive loads.

The LT1137A is fully compliant with all EIA-RS232 specifications. Special bipolar construction techniques protect the drivers and receivers beyond the fault conditions stipulated for RS232. Driver outputs and receiver inputs can be shorted to  $\pm 30\text{V}$  without damaging the device or the power supply generator. In addition, the RS232 I/O pins are resilient to multiple  $\pm 10\text{kV}$  ESD strikes.

The transceiver has two SHUTDOWN modes. One mode disables the drivers and the charge pump, the other shuts down all circuitry. While shut down, the drivers and receivers assume high impedance output states.

### TYPICAL APPLICATION

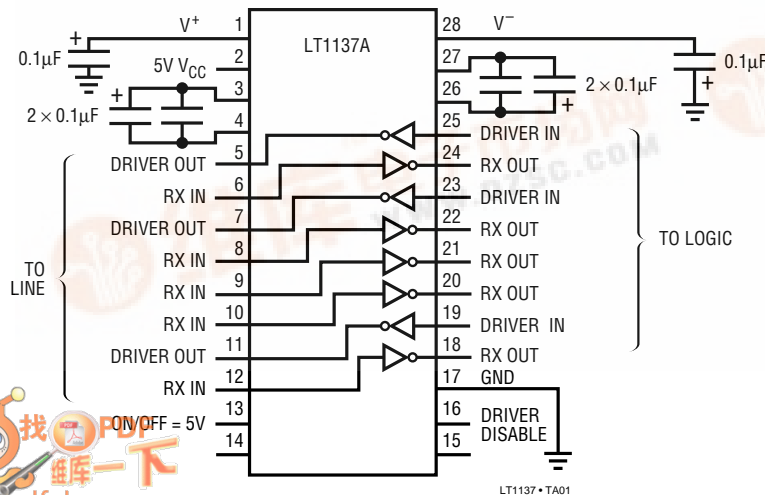

### Output Waveforms

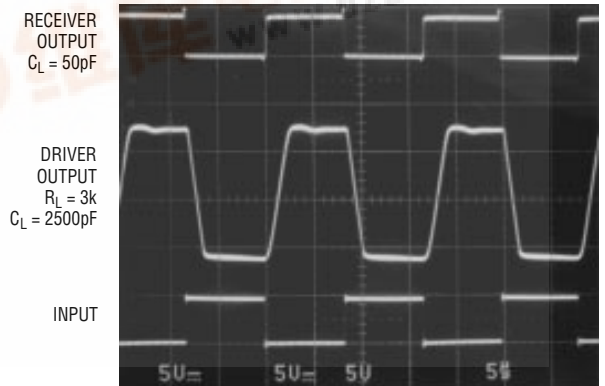

# LT1137A

## ABSOLUTE MAXIMUM RATINGS

(Note 1)

Supply Voltage ( $V_{CC}$ ) .....	6V
$V^+$ .....	13.2V
$V^-$ (Note 7) .....	-6.5V
Input Voltage	
Driver .....	$V^-$ to $V^+$
Receiver .....	-30V to 30V
Output Voltage	
Driver .....	-30V to 30V
Receiver .....	-0.3V to $V_{CC} + 0.3V$
Short Circuit Duration	
$V^+$ .....	30 sec
$V^-$ .....	30 sec
Driver Output .....	Indefinite
Receiver Output .....	Indefinite
Operating Temperature Range	
LT1137AC .....	0°C to 70°C
LT1137AI .....	-40°C to 85°C
Storage Temperature Range .....	-65°C to 150°C
Lead Temperature (Soldering, 10 sec) .....	300°C

## PACKAGE/ORDER INFORMATION

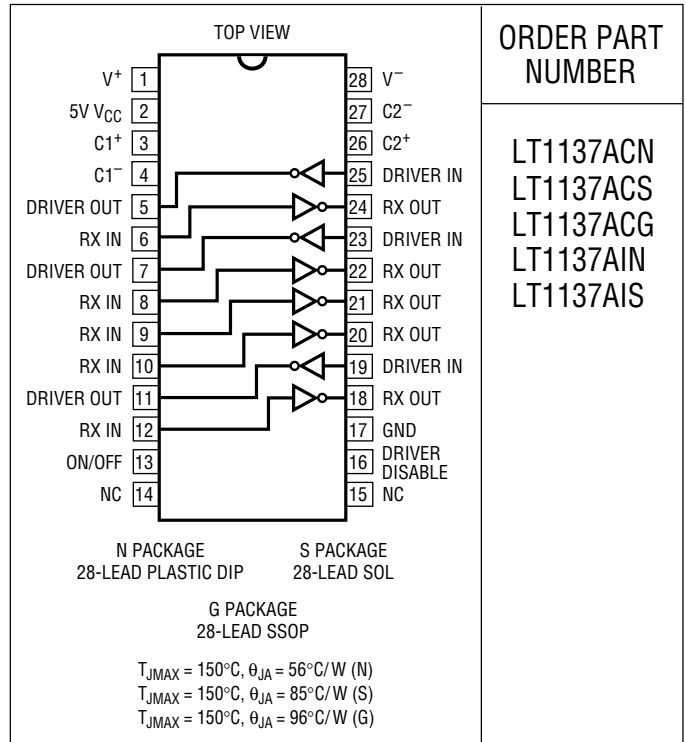

ORDER PART NUMBER

LT1137ACN  
 LT1137ACS  
 LT1137ACG  
 LT1137AIN  
 LT1137AIS

Consult factory for Military grade parts.

## ELECTRICAL CHARACTERISTICS (Note 2)

PARAMETER	CONDITIONS	MIN	TYP	MAX	UNITS
<b>Power Supply Generator</b>					
$V^+$ Output			8.6		V
$V^-$ Output			-7.2		V
Supply Current ( $V_{CC}$ )	(Note 3)	●	12	17	mA
Supply Current When OFF ( $V_{CC}$ )	SHUTDOWN (Note 4) DRIVER DISABLE	●	1 4	10	$\mu$ A mA
Supply Rise Time SHUTDOWN to Turn-On	$C1, C2, C^+, C^- = 1\mu F$ , $C^+, C^- = 0.1\mu F, C1, C2 = 0.2\mu F$		2.0 0.2		ms ms
ON/OFF Pin Thresholds	Input Low Level (Device SHUTDOWN) Input High Level (Device Enabled)	● ●	1.4 2.4	0.8	V V
ON/OFF Pin Current	$0V \leq V_{ON/OFF} \leq 5V$	●	-15	80	$\mu$ A
Driver Disable Pin Thresholds	Input Low Level (Drivers Enabled) Input High Level (Drivers Disabled)	● ●	1.4 2.4	0.8	V V
Driver Disable Pin Current	$0V \leq V_{DRIVER\ DISABLE} \leq 5V$	●	-10	500	$\mu$ A
Oscillator Frequency			130		kHz

## ELECTRICAL CHARACTERISTICS (Note 2)

PARAMETER	CONDITIONS		MIN	TYP	MAX	UNITS	
<b>Any Driver</b>							
Output Voltage Swing	Load = 3k to GND	Positive	●	5.0	7.5	V	
		Negative	●		-6.3	-5.0	V
Logic Input Voltage Level	Input Low Level ( $V_{OUT} = \text{High}$ )		●		1.4	0.8	V
	Input High Level ( $V_{OUT} = \text{Low}$ )		●	2.0	1.4		V
Logic Input Current	$0.8V \leq V_{IN} \leq 2V$		●		5	20	$\mu\text{A}$
Output Short-Circuit Current	$V_{OUT} = 0V$				$\pm 17$		mA
Output Leakage Current	SHUTDOWN $V_{OUT} = \pm 25V$ (Note 4)		●		10	100	$\mu\text{A}$
Slew Rate	$R_L = 3k, C_L = 51\text{pF}$				15	30	V/ $\mu\text{s}$
	$R_L = 3k, C_L = 2500\text{pF}$		4	15			V/ $\mu\text{s}$
Propagation Delay	Output Transition $t_{HL}$ High to Low (Note 5)				0.6	1.3	$\mu\text{s}$
	Output Transition $t_{LH}$ Low to High				0.5	1.3	$\mu\text{s}$
<b>Any Receiver</b>							
Input Voltage Thresholds	Input Low Threshold ( $V_{OUT} = \text{High}$ )		●	0.8	1.3		V
	Input High Threshold ( $V_{OUT} = \text{Low}$ )		●		1.7	2.4	V
Hysteresis			●	0.1	0.4	1.0	V
Input Resistance	$V_{IN} = \pm 10V$			3	5	7	k $\Omega$
Output Voltage	Output Low, $I_{OUT} = -1.6\text{mA}$		●		0.2	0.4	V
	Output High, $I_{OUT} = 160\mu\text{A}$ ( $V_{CC} = 5V$ )		●	3.5	4.2		V
Output Leakage Current	SHUTDOWN (Note 4) $0 \leq V_{OUT} \leq V_{CC}$		●		1	10	$\mu\text{A}$
Output Short-Circuit Current	Sinking Current, $V_{OUT} = V_{CC}$				-20	-10	mA
	Sourcing Current, $V_{OUT} = 0V$			10	20		mA
Propagation Delay	Output Transition $t_{HL}$ High to Low (Note 6)				250	600	ns
	Output Transition $t_{LH}$ Low to High				350	600	ns

The ● denotes specifications which apply over the operating temperature range ( $0^\circ\text{C} \leq T_A \leq 70^\circ\text{C}$  for commercial grade, and  $-40^\circ\text{C} \leq T_A \leq 85^\circ\text{C}$  for industrial grade).

**Note 1:** Absolute Maximum Ratings are those values beyond which the life of the device may be impaired.

**Note 2:** Testing done at  $V_{CC} = 5V$  and  $V_{ON/OFF} = 3V$ .

**Note 3:** Supply current is measured with driver and receiver outputs unloaded and the driver inputs tied high.

**Note 4:** Supply current and leakage current measurements in SHUTDOWN are performed with  $V_{ON/OFF} = 0.1V$ . Supply current measurements using DRIVER DISABLE are performed with  $V_{DRIVER\ DISABLE} = 3V$ .

**Note 5:** For driver delay measurements,  $R_L = 3k$  and  $C_L = 51\text{pF}$ . Trigger points are set between the driver's input logic threshold and the output transition to the zero crossing ( $t_{HL} = 1.4V$  to  $0V$  and  $t_{LH} = 1.4V$  to  $0V$ ).

**Note 6:** For receiver delay measurements,  $C_L = 51\text{pF}$ . Trigger points are set between the receiver's input logic threshold and the output transition to standard TTL/CMOS logic threshold ( $t_{HL} = 1.3V$  to  $2.4V$  and  $t_{LH} = 1.7V$  to  $0.8V$ ).

**Note 7:** Absolute maximum externally applied voltage. Internal charge pump may force a larger value on this pin.

# LT1137A

## TYPICAL PERFORMANCE CHARACTERISTICS

**Driver Output Voltage**

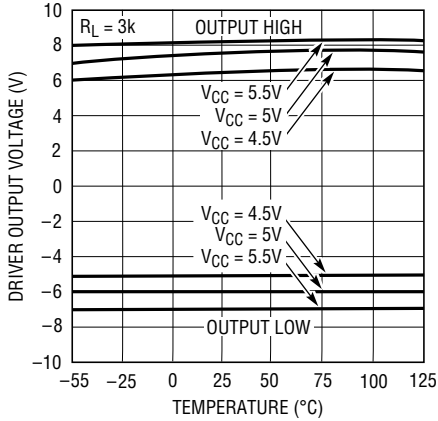

LT1137A • TPC01

**Receiver Input Thresholds**

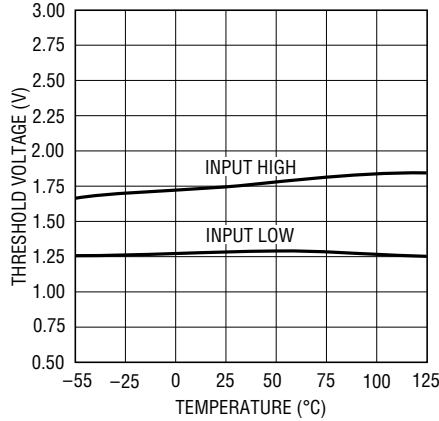

LT1137A • TPC02

**Supply Current vs Data Rate**

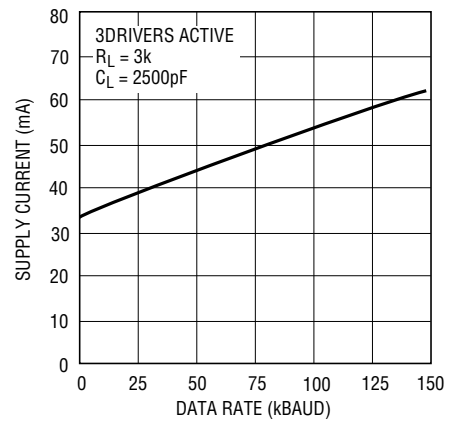

LT1137A • TPC03

**Supply Current in SHUTDOWN**

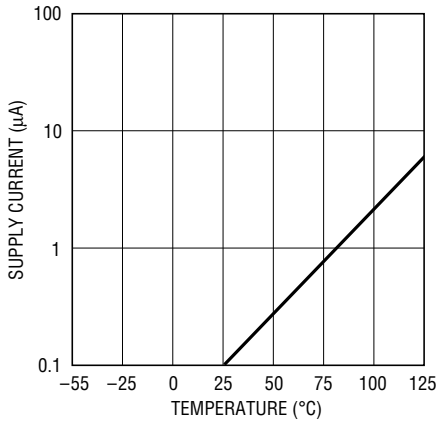

LT1137A • TPC04

**Supply Current in DRIVER DISABLE**

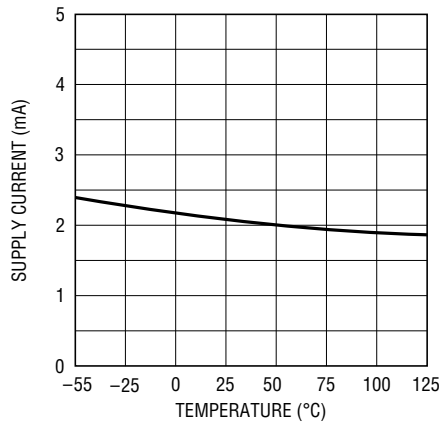

LT1137A • TPC05

**Driver Disable Threshold**

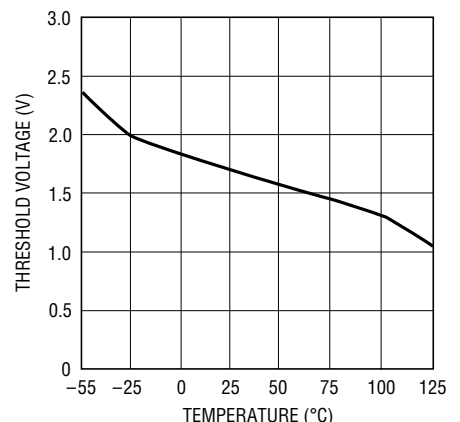

LT1137A • TPC06

**On/Off Thresholds**

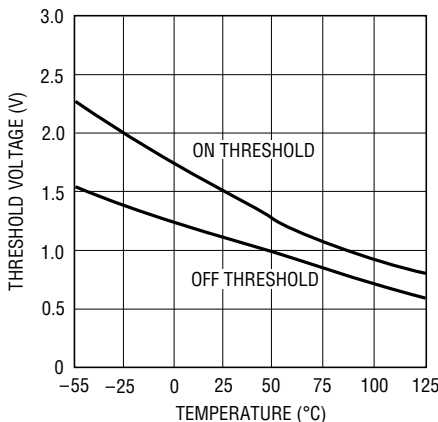

LT1137A • TPC07

**Supply Current**

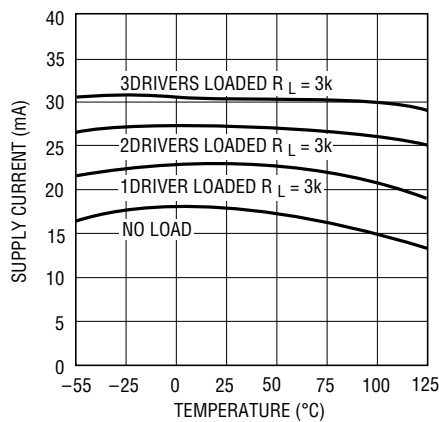

LT1137A • TPC08

**Driver Leakage in SHUTDOWN**

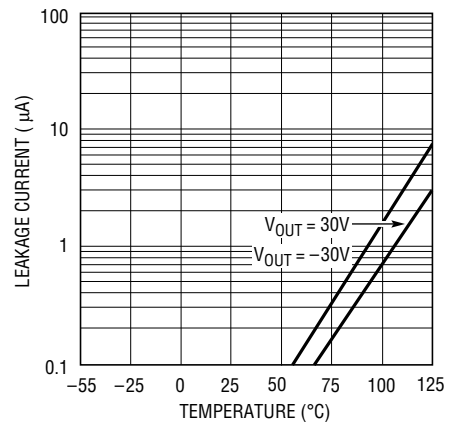

LT1137A • TPC09

## TYPICAL PERFORMANCE CHARACTERISTICS

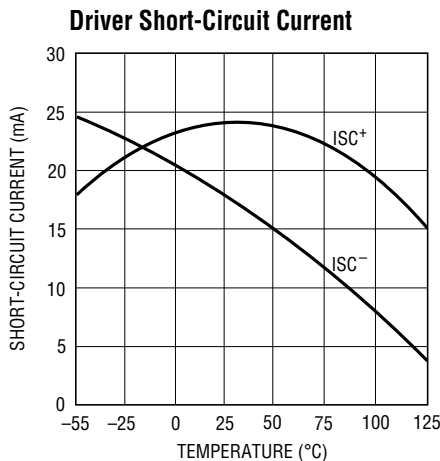

LT1137A • TPC10

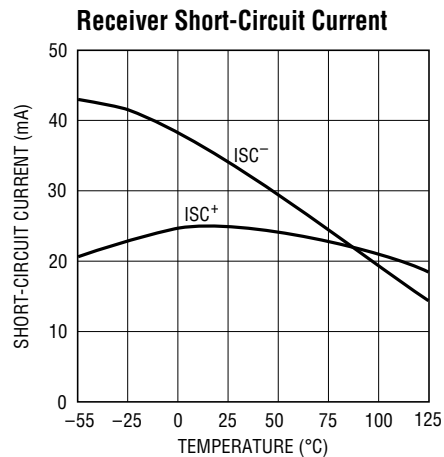

LT1137A • TPC11

### SHUTDOWN to Driver Output

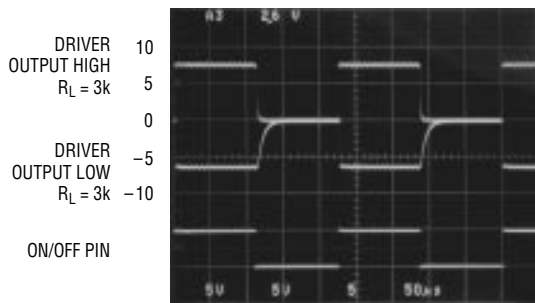

LT1137A • TPC12

### Driver Output Waveforms

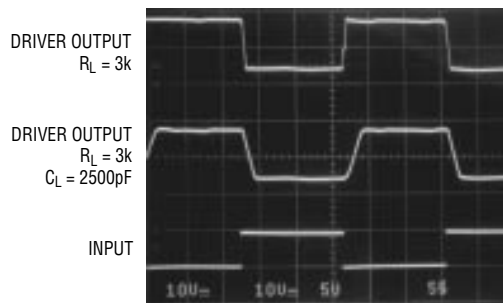

LT1137A • TPC13

## PIN FUNCTIONS

**V<sub>CC</sub>**: 5V Input Supply Pin. Supply current drops to zero in the SHUTDOWN mode. This pin should be decoupled with a 0.1μF ceramic capacitor close to the package pin. Insufficient supply bypassing can result in low output drive levels and erratic charge pump operation.

**GND**: Ground Pin.

**ON/OFF**: TTL/CMOS Compatible Operating Mode Control. A logic low puts the device in the SHUTDOWN mode which reduces input supply current to zero and places all of the drivers and receivers in high impedance state. A logic high fully enables the transceiver.

**DRIVER DISABLE**: This pin provides an alternate control for the charge pump and RS232 drivers. A logic high on this pin shuts down the charge pump and places all drivers

in a high impedance state. Receivers remain active under these conditions. Floating the driver disable pin or driving it to a logic low level fully enables the transceiver. A logic low on the On/Off pin supersedes the state of the Driver Disable pin. Supply current drops to 4mA when in DRIVER DISABLE mode.

**V<sup>+</sup>**: Positive Supply Output (RS232 Drivers).  $V^+ \approx 2V_{CC} - 1.5V$ . This pin requires an external charge storage capacitor  $C \geq 0.1\mu F$ , tied to ground or  $V_{CC}$ . Larger value capacitors may be used to reduce supply ripple. With multiple transceivers, the  $V^+$  and  $V^-$  pins may be paralleled into common capacitors. For large numbers of transceivers, increasing the size of the shared common storage capacitors is recommended to reduce ripple.

# LT1137A

## PIN FUNCTIONS

**V<sup>-</sup>:** Negative Supply Output (RS232 Drivers).  $V^- \approx -(2V_{CC} - 2.5V)$ . This pin requires an external charge storage capacitor  $C \geq 0.1\mu F$ .  $V^-$  is short-circuit proof for 30 seconds.

**C1<sup>+</sup>, C1<sup>-</sup>, C2<sup>+</sup>, C2<sup>-</sup>:** Commutating Capacitor Inputs. These pins require two external capacitors  $C \geq 0.2\mu F$ : one from C1<sup>+</sup> to C1<sup>-</sup>, and another from C2<sup>+</sup> to C2<sup>-</sup>. To maintain charge pump efficiency, the capacitor's effective series resistance should be less than  $2\Omega$ . For  $C \geq 1\mu F$ , low ESR tantalum capacitors work well in this application, although small value ceramic capacitors may be used with a minimal reduction in charge pump compliance. In applications where larger positive voltages are available, such as 12V, C1 may be omitted and the positive voltage may be connected directly to the C1<sup>+</sup> pin. In this mode of operation, the V<sup>+</sup> pin should be decoupled with a  $0.1\mu F$  ceramic capacitor.

**DRIVER IN:** RS232 Driver Input Pins. These inputs are TTL/CMOS compatible. Inputs should not be allowed to float. Tie unused inputs to  $V_{CC}$ .

**DRIVER OUT:** Driver Outputs at RS232 Voltage Levels. Driver output swing meets RS232 levels for loads up to 3k.

Slew rates are controlled for lightly loaded lines. Output current capability is sufficient for load conditions up to 2500pF. Outputs are in a high impedance state when in SHUTDOWN mode,  $V_{CC} = 0V$ , or when the driver disable pin is active. Outputs are fully short-circuit protected from  $V^- + 30V$  to  $V^+ - 30V$ . Applying higher voltages will not damage the device if the overdrive is moderately current limited. Short circuits on one output can load the power supply generator and may disrupt the signal levels of the other outputs. The driver outputs are protected against ESD to  $\pm 10kV$  for human body model discharges.

**RX IN:** Receiver Inputs. These pins accept RS232 level signals ( $\pm 30V$ ) into a protected 5k terminating resistor. The receiver inputs are protected against ESD to  $\pm 10kV$  for human body model discharges. Each receiver provides 0.4V of hysteresis for noise immunity. Open receiver inputs assume a logic low state.

**RX OUT:** Receiver Outputs with TTL/CMOS Voltage Levels. Outputs are in a high impedance state when in SHUTDOWN mode to allow data line sharing. Outputs are fully short-circuit protected to ground or  $V_{CC}$  with the power on, off, or in SHUTDOWN mode.

## ESD PROTECTION

The RS232 line inputs of the LT1137A have on-chip protection from ESD transients up to  $\pm 10kV$ . The protection structures act to divert the static discharge safely to system ground. In order for the ESD protection to function effectively, the power supply and ground pins of the LT1137A must be connected to ground through low impedances. The power supply decoupling capacitors and charge pump storage capacitors provide this low impedance in normal application of the circuit. The only constraint is that low ESR capacitors must be used for bypassing and charge storage. ESD testing must be done with pins  $V_{CC}$ ,  $V^+$ ,  $V^-$  and GND shorted to ground or connected with low ESR capacitors.

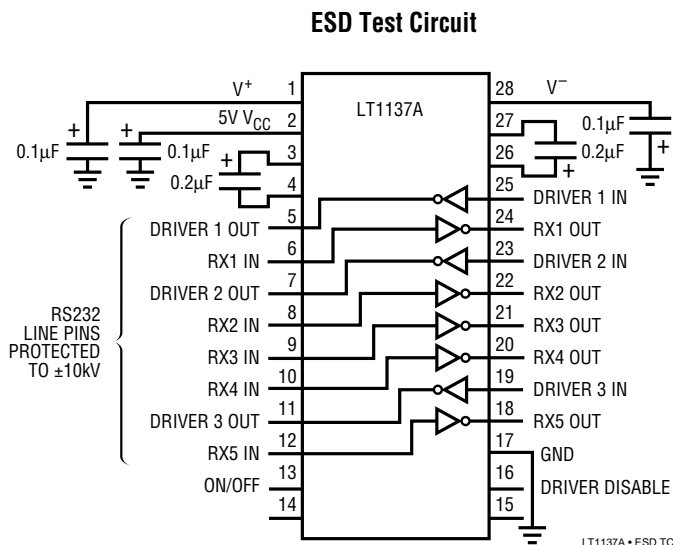

# TYPICAL APPLICATIONS

## Operation Using 5V and 12V Power Supplies

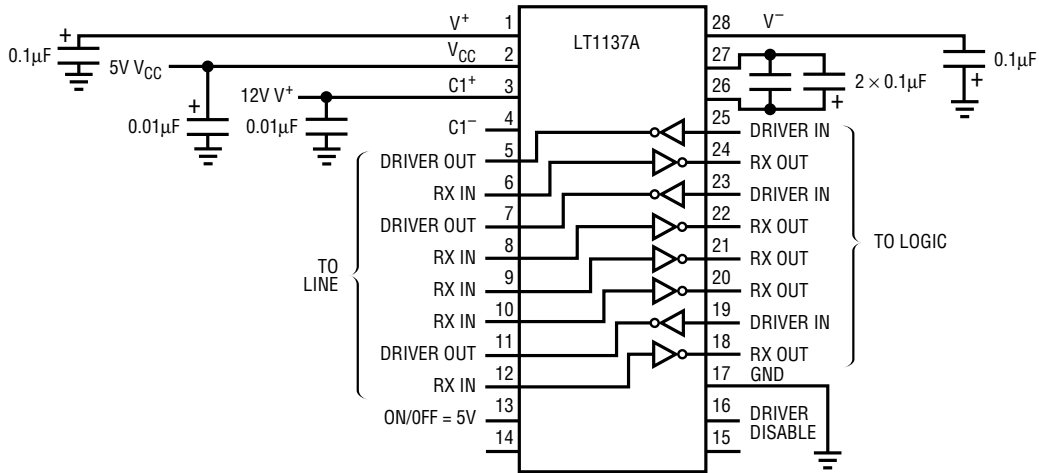

LT1137A • TA03

## Typical Mouse Driving Application

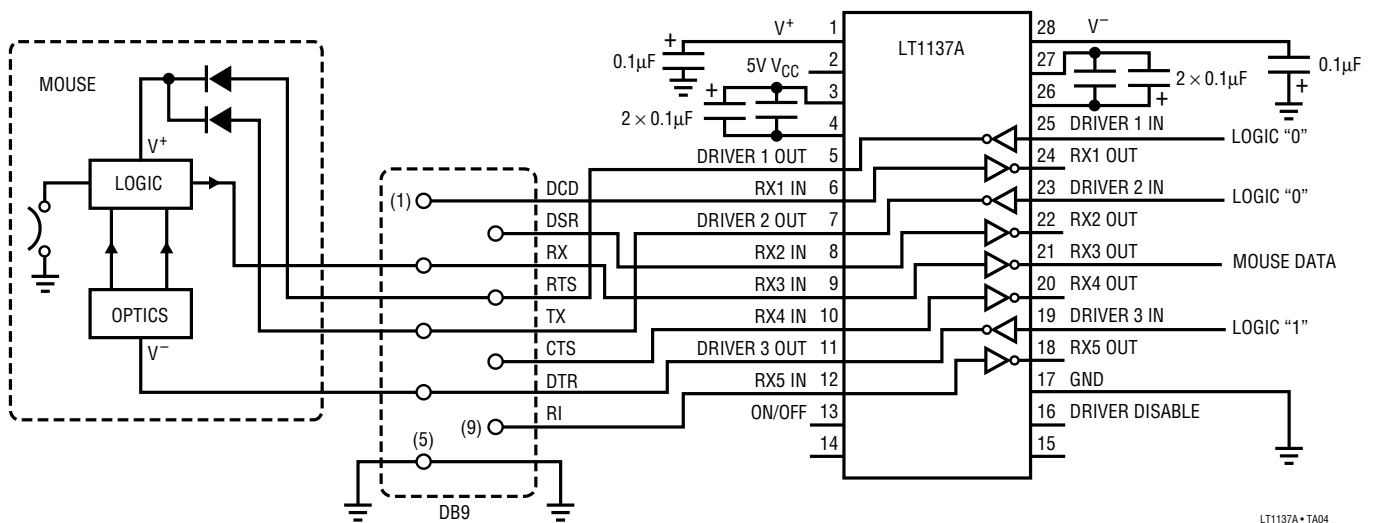

LT1137A • TA04

