



# LT1180A/LT1181A

## Low Power 5V RS232 Dual Driver/Receiver with 0.1µF Capacitors

### FEATURES

- ESD Protection over  $\pm 10\text{kV}$
- Uses Small Capacitors:  $0.1\mu\text{F}$
- 120kBaud Operation for  $R_L = 3\text{k}$ ,  $C_L = 2500\text{pF}$
- 250kBaud Operation for  $R_L = 3\text{k}$ ,  $C_L = 1000\text{pF}$
- Outputs Withstand  $\pm 30\text{V}$  Without Damage
- CMOS Comparable Low Power: 40mW
- Operates from a Single 5V Supply
- Rugged Bipolar Design
- Outputs Assume a High Impedance State When Off or Powered Down
- Meets All RS232 Specifications
- Available With or Without Shutdown
- Absolutely No Latch-up
- Available in SO Package

### APPLICATIONS

- Portable Computers
- Battery-Powered Systems
- Power Supply Generator
- Terminals
- Modems

### DESCRIPTION

The LT1180A/LT1181A are dual RS232 driver/receiver pairs with integral charge pump to generate RS232 voltage levels from a single 5V supply. These circuits feature rugged bipolar design to provide operating fault tolerance and ESD protection unmatched by competing CMOS designs. Using only  $0.1\mu\text{F}$  external capacitors, these circuits consume only 40mW of power, and can operate to 120k baud even while driving heavy capacitive loads. New ESD structures on the chip allow the LT1180A/LT1181A to survive multiple  $\pm 10\text{kV}$  strikes, eliminating the need for costly TransZorbs<sup>®</sup> on the RS232 line pins. The LT1180A/LT1181A are fully compliant with EIA RS232 standards. Driver outputs are protected from overload, and can be shorted to ground or up to  $\pm 30\text{V}$  without damage. During SHUTDOWN or power-off conditions, driver and receiver outputs are in a high impedance state, allowing line sharing.

The LT1181A is available in 16-pin DIP and SO packages. The LT1180A is supplied in 18-pin DIP and SO packages for applications which require SHUTDOWN.

TransZorb is a registered trademark of General Instruments, GSI

### TYPICAL APPLICATION

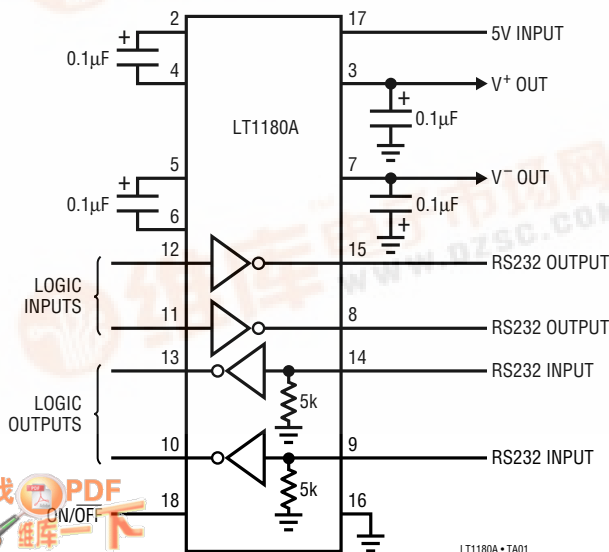

Output Waveforms

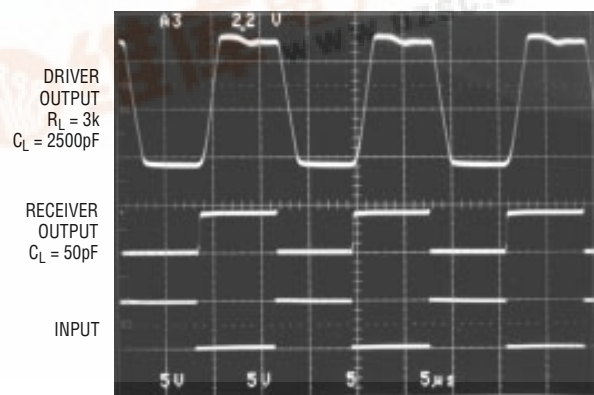

LT1180A • TA02



# LT1180A/LT1181A

## ABSOLUTE MAXIMUM RATINGS

Supply Voltage ( $V_{CC}$ ) .....	6V	Short-Circuit Duration	
$V^+$ .....	13.2V	$V^+$ .....	30 sec
$V^-$ .....	-13.2V	$V^-$ .....	30 sec
Input Voltage		Driver Output .....	Indefinite
Driver .....	$V^-$ to $V^+$	Receiver Output .....	Indefinite
Receiver .....	-30V to 30V	Operating Temperature Range	
ON/OFF .....	-0.3V to 12V	LT1180AI/LT1181AI .....	-40°C to 85°C
Output Voltage		LT1180AC/LT1181AC .....	0°C to 70°C
Driver .....	$V^+ - 30V$ to $V^- + 30V$	Storage Temperature Range .....	-65°C to 150°C
Receiver .....	-0.3V to $V_{CC} + 0.3V$	Lead Temperature (Soldering, 10 sec) .....	300°C

## PACKAGE/ORDER INFORMATION

<p>TOP VIEW</p> <p>N PACKAGE 18-LEAD PLASTIC DIP</p> <p>S PACKAGE 18-LEAD PLASTIC SOL</p> <p><math>T_{JMAX} = 125^\circ\text{C}</math>, <math>\theta_{JA} = 80^\circ\text{C/W}</math>, <math>\theta_{JC} = 36^\circ\text{C/W}</math> (N)  <math>T_{JMAX} = 125^\circ\text{C}</math>, <math>\theta_{JA} = 90^\circ\text{C/W}</math>, <math>\theta_{JC} = 26^\circ\text{C/W}</math> (S)</p>	<p>ORDER PART NUMBER</p> <p>LT1180AIN LT1180ACN LT1180ACS</p>	<p>TOP VIEW</p> <p>N PACKAGE 16-LEAD PLASTIC DIP</p> <p>S PACKAGE 16-LEAD PLASTIC SOL</p> <p><math>T_{JMAX} = 125^\circ\text{C}</math>, <math>\theta_{JA} = 90^\circ\text{C/W}</math>, <math>\theta_{JC} = 46^\circ\text{C/W}</math> (N)  <math>T_{JMAX} = 125^\circ\text{C}</math>, <math>\theta_{JA} = 95^\circ\text{C/W}</math>, <math>\theta_{JC} = 27^\circ\text{C/W}</math> (S)</p>	<p>ORDER PART NUMBER</p> <p>LT1181AIN LT1181ACN LT1181ACS</p>
---	---	---	---

Consult factory for Military grade parts.

## ELECTRICAL CHARACTERISTICS (Note 2)

PARAMETER	CONDITIONS	MIN	TYP	MAX	UNITS
<b>Power Supply Generator</b>					
$V^+$ Output			7.9		V
$V^-$ Output			-7.0		V
Supply Current ( $V_{CC}$ )	(Note 3), $T_A = 25^\circ\text{C}$	●	9	13	mA
Supply Current When OFF ( $V_{CC}$ )	SHUTDOWN (Note 4) LT1180A Only	●	1	10	$\mu\text{A}$
Supply Rise Time	$C1 = C2 = C3 = C4 = 0.1\mu\text{F}$		0.2		ms
SHUTDOWN to Turn-On	LT1180A Only		0.2		ms
ON/OFF Pin Thresholds	Input Low Level (Device SHUTDOWN) Input High Level (Device Enabled)	●	0.8	1.2	V
ON/OFF Pin Current	$0V \leq V_{ON/OFF} \leq 5V$	●	-15	80	$\mu\text{A}$
Oscillator Frequency			130		kHz
<b>Driver</b>					
Output Voltage Swing	Load = 3k to GND	●	5.0	7.5	V
	Positive	●	-6.3	-5.0	V
	Negative				
Logic Input Voltage Level	Input Low Level ( $V_{OUT} = \text{High}$ ) Input High Level ( $V_{OUT} = \text{Low}$ )	●	1.4	0.8	V
		●	2.0	1.4	V

## ELECTRICAL CHARACTERISTICS (Note 2)

PARAMETER	CONDITIONS	MIN	TYP	MAX	UNITS
Logic Input Current	$0.8V \leq V_{IN} \leq 2.0V$	●	5	20	$\mu A$
Output Short-Circuit Current	$V_{OUT} = 0V$	$\pm 9$	17		mA
Output Leakage Current	SHUTDOWN $V_{OUT} = \pm 30V$ (Note 4)	●	10	100	$\mu A$
Date Rate	$R_L = 3k, C_L = 2500pF$ $R_L = 3k, C_L = 1000pF$		120 250		kBaud kBaud
Slew Rate	$R_L = 3k, C_L = 51pF$ $R_L = 3k, C_L = 2500pF$		4 15 7	30	$V/\mu s$ $V/\mu s$
Propagation Delay	Output Transition $t_{HL}$ High-to-Low (Note 5) Output Transition $t_{LH}$ Low-to-High			0.6 1.3 0.5 1.3	$\mu s$ $\mu s$
<b>Receiver</b>					
Input Voltage Thresholds	Input Low Threshold ( $V_{OUT} = \text{High}$ ) Input High Threshold ( $V_{OUT} = \text{Low}$ )		0.8 1.3 1.7	2.4	V V
Hysteresis		●	0.1	0.4 1.0	V
Input Resistance	$V_{IN} = \pm 10V$		3	5 7	k $\Omega$
Output Leakage Current	SHUTDOWN (Note 4) $0 \leq V_{OUT} \leq V_{CC}$	●		1 10	$\mu A$
Output Voltage	Output Low, $I_{OUT} = -1.6mA$ Output High, $I_{OUT} = 160\mu A$ ( $V_{CC} = 5V$ )	● ●		0.2 0.4	V V
Output Short-Circuit Current	Sinking Current, $V_{OUT} = V_{CC}$ Sourcing Current, $V_{OUT} = 0V$		10	-20 20	mA mA
Propagation Delay	Output Transition $t_{HL}$ High-to-Low (Note 6) Output Transition $t_{LH}$ Low-to-High			250 350 600 600	ns ns

The ● denotes specifications which apply over the operating temperature range ( $0^\circ C \leq T_A \leq 70^\circ C$  for commercial grade, and  $-40^\circ C \leq T_A \leq 85^\circ C$  for industrial grade).

**Note 1:** Absolute Maximum Ratings are those values beyond which the life of the device may be impaired.

**Note 2:** Testing done at  $V_{CC} = 5V$  and  $V_{ON/OFF} = 3V$ , unless otherwise specified.

**Note 3:** Supply current is measured as the average over several charge pump cycles.  $C^+ = C^- = C1 = C2 = 0.1\mu F$ . All outputs are open, with all driver inputs tied high.

**Note 4:** Supply current measurements in SHUTDOWN are performed with  $V_{ON/OFF} \leq 0.1V$ .

**Note 5:** For driver delay measurements,  $R_L = 3k$  and  $C_L = 51pF$ . Trigger points are set between the driver's input logic threshold and the output transition to the zero crossing ( $t_{HL} = 1.4V$  to  $0V$  and  $t_{LH} = 1.4V$  to  $0V$ ).

**Note 6:** For receiver delay measurements,  $C_L = 51pF$ . Trigger points are set between the receiver's input logic threshold and the output transition to standard TTL/CMOS logic threshold ( $t_{HL} = 1.3V$  to  $2.4V$  and  $t_{LH} = 1.7V$  to  $0.8V$ ).

## TYPICAL PERFORMANCE CHARACTERISTICS

Driver Maximum Output Voltage vs Load Capacitance

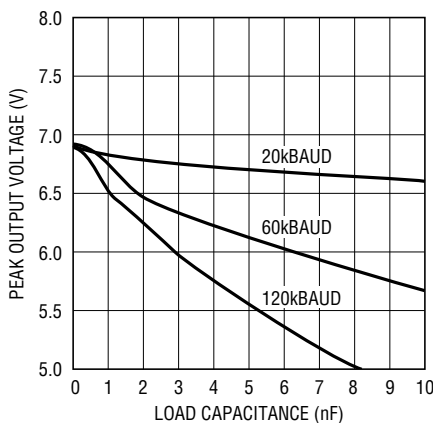

LT1180A • TPC01

Driver Minimum Output Voltage vs Load Capacitance

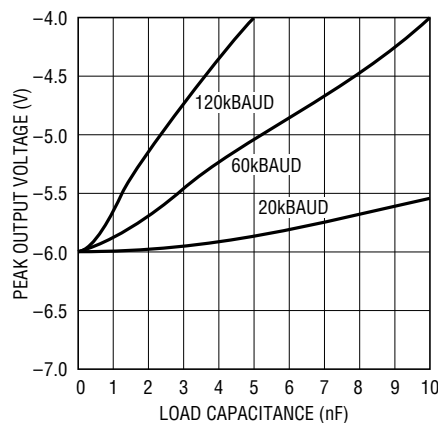

LT1180A • TPC02

Driver Output Voltage

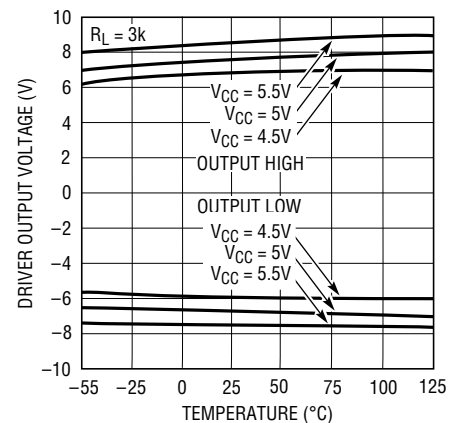

LT1180A • TPC03

# LT1180A/LT1181A

## TYPICAL PERFORMANCE CHARACTERISTICS

**Receiver Input Thresholds**

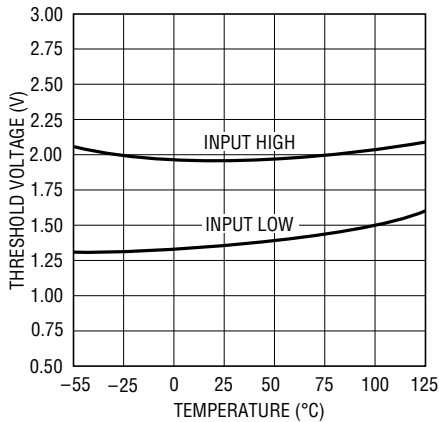

LT1180A • TPC04

**Supply Current vs Data Rate**

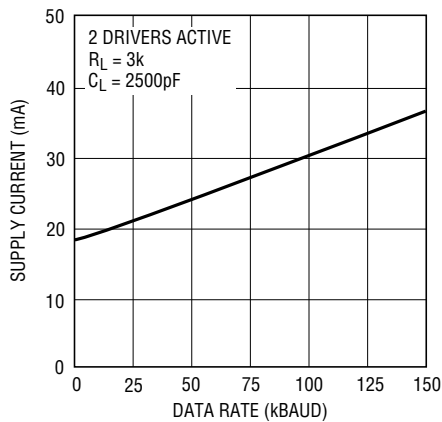

LT1180A • TPC05

**ON/OFF Thresholds**

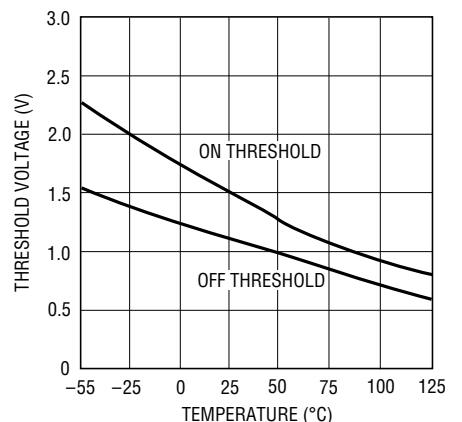

LT1180A • TPC06

**Supply Current**

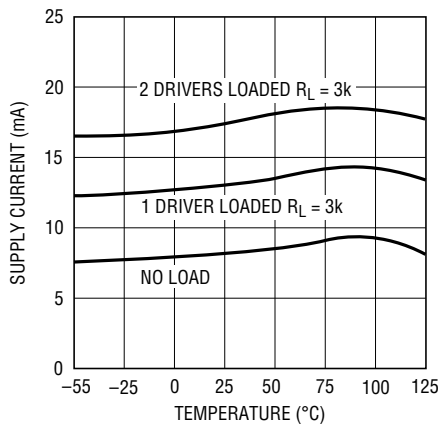

LT1180A • TPC07

**Driver Leakage in Shutdown**

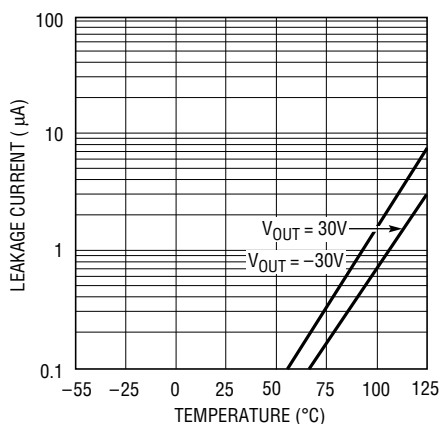

LT1180A • TPC08

**Driver Short-Circuit Current**

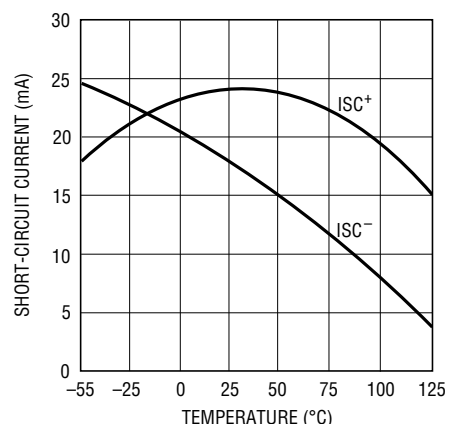

LT1180A • TPC09

**Receiver Short-Circuit Current**

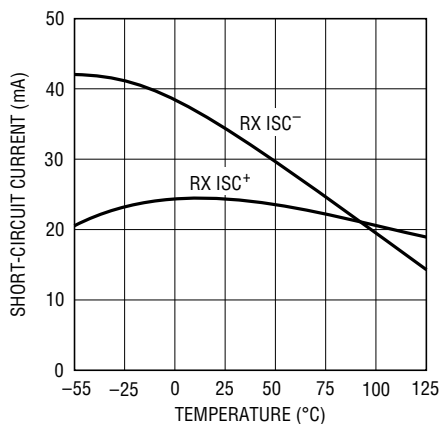

LT1180A • TPC10

**Slew Rate vs Load Capacitance**

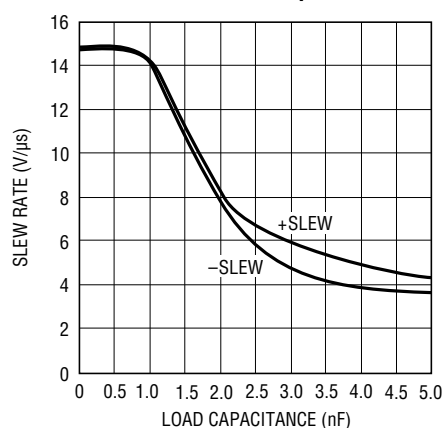

LT1180A • TPC11

## TYPICAL PERFORMANCE CHARACTERISTICS

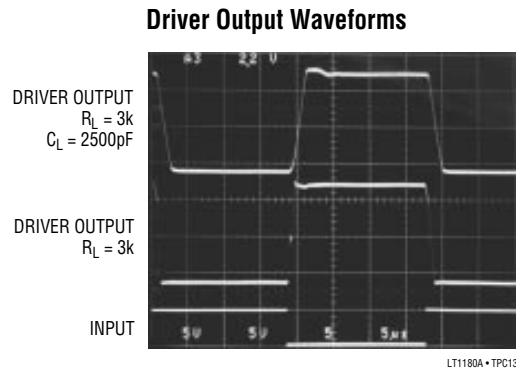
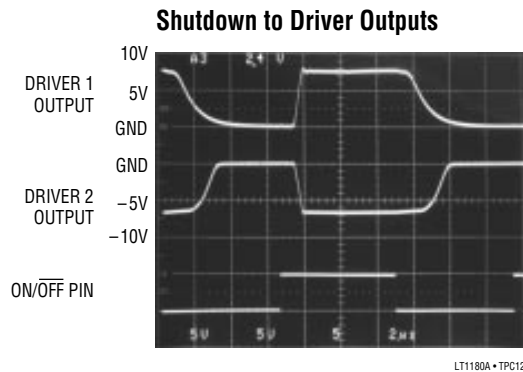

## PIN FUNCTIONS

**V<sub>CC</sub>**: 5V Input Supply Pin. This pin should be decoupled with a 0.1µF ceramic capacitor close to the package pin. Insufficient supply bypassing can result in low output drive levels and erratic charge pump operation.

**GND**: Ground Pin.

**ON/OFF**: A TTL/CMOS Compatible Operating Mode Control. A logic low puts the LT1180A in SHUTDOWN mode. Supply current drops to zero and both driver and receiver outputs assume a high impedance state. A logic high fully enables the device.

**V<sup>+</sup>**: Positive Supply Output (RS232 Drivers).  $V^+ \approx 2V_{CC} - 1.5V$ . This pin requires an external charge storage capacitor  $C \geq 0.1\mu F$ , tied to ground or  $V_{CC}$ . Larger value capacitors may be used to reduce supply ripple. With multiple transceivers, the  $V^+$  and  $V^-$  pins may be paralleled into common capacitors.

**V<sup>-</sup>**: Negative Supply Output (RS232 Drivers).  $V^- \approx -(2V_{CC} - 2.5V)$ . This pin requires an external charge storage capacitor  $C \geq 0.1\mu F$ . Larger value capacitors may be used to reduce supply ripple. With multiple transceivers, the  $V^+$  and  $V^-$  pins may be paralleled into common capacitors.

**TR1 IN, TR2 IN**: RS232 Driver Input Pins. These inputs are TTL/CMOS compatible. Inputs should not be allowed to float. Tie unused inputs to  $V_{CC}$ .

**TR1 OUT, TR2 OUT**: Driver Outputs at RS232 Voltage Levels. Driver output swing meets RS232 levels for loads up to 3k. Slew rates are controlled for lightly loaded lines.

Output current capability is sufficient for load conditions up to 2500pF. Outputs are in a high impedance state when in SHUTDOWN mode,  $V_{CC} = 0V$ , or when the driver disable pin is active. Outputs are fully short-circuit protected from  $V^- + 30V$  to  $V^+ - 30V$ . Applying higher voltages will not damage the device if the overdrive is moderately current limited. Short circuits on one output can load the power supply generator and may disrupt the signal levels of the other outputs. The driver outputs are protected against ESD to  $\pm 10kV$  for human body model discharges.

**REC1 IN, REC2 IN**: Receiver Inputs. These pins accept RS232 level signals ( $\pm 30V$ ) into a protected 5k terminating resistor. The receiver inputs are protected against ESD to  $\pm 10kV$  for human body model discharges. Each receiver provides 0.4V of hysteresis for noise immunity. Open receiver inputs assume a logic low state.

**REC1 OUT, REC2 OUT**: Receiver outputs with TTL/CMOS Voltage Levels. Outputs are in a high impedance state when in SHUTDOWN mode to allow data line sharing. Outputs are fully short-circuit protected to ground or  $V_{CC}$  with the power ON, OFF or in the SHUTDOWN mode.

**C1<sup>+</sup>, C1<sup>-</sup>, C2<sup>+</sup>, C2<sup>-</sup>**: Commutating Capacitor Inputs. These pins require two external capacitors  $C \geq 0.1\mu F$ : one from  $C1^+$  to  $C1^-$  and another from  $C2^+$  to  $C2^-$ .  $C1$  should be deleted if a separate 12V supply is available and connected to pin  $C1^+$ . Similarly,  $C2$  should be deleted if a separate  $-12V$  supply is connected to pin  $V^-$ .

# LT1180A/LT1181A

## ESD PROTECTION

The RS232 line inputs of the LT1180A/LT1181A have on-chip protection from ESD transients up to  $\pm 10\text{kV}$ . The protection structures act to divert the static discharge safely to system ground. In order for the ESD protection to function effectively, the power supply and ground pins of the circuit must be connected to ground through low impedances. The power supply decoupling capacitors and charge pump storage capacitors provide this low impedance in normal application of the circuit. The only constraint is that low ESR capacitors must be used for bypassing and charge storage. ESD testing must be done with pins  $V_{CC}$ ,  $V_L$ ,  $V^+$ ,  $V^-$ , and GND shorted to ground or connected with low ESR capacitors.

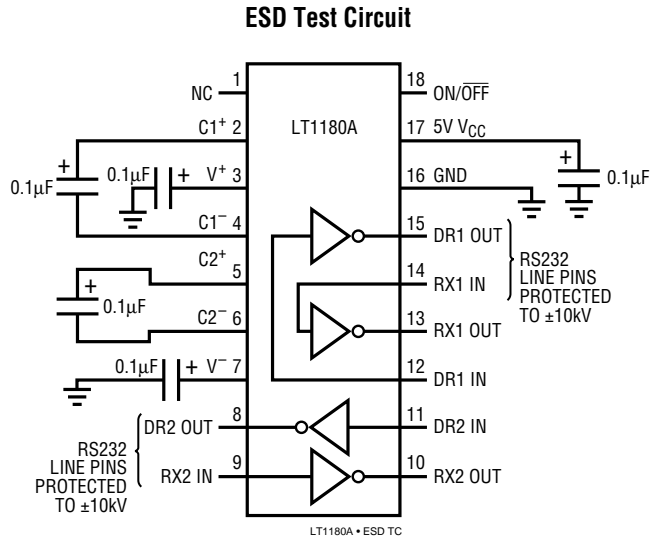

## TYPICAL APPLICATIONS

### Operation Using 5V and 12V Power Supplies

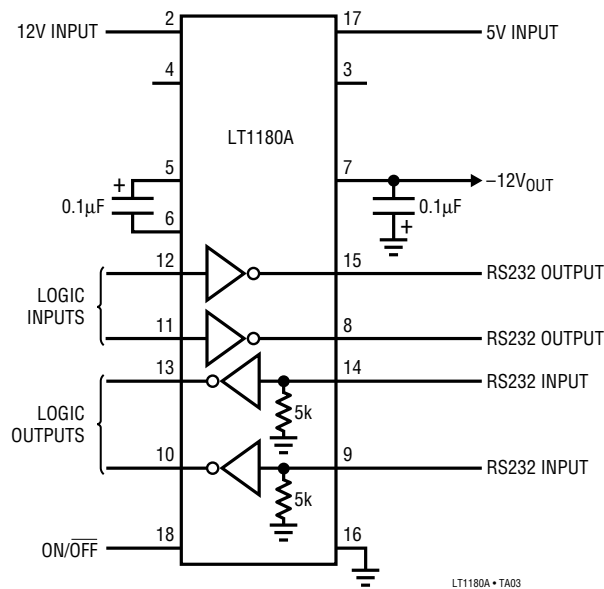

# TYPICAL APPLICATIONS

Supporting an LT1039 (Triple Driver/Receiver)

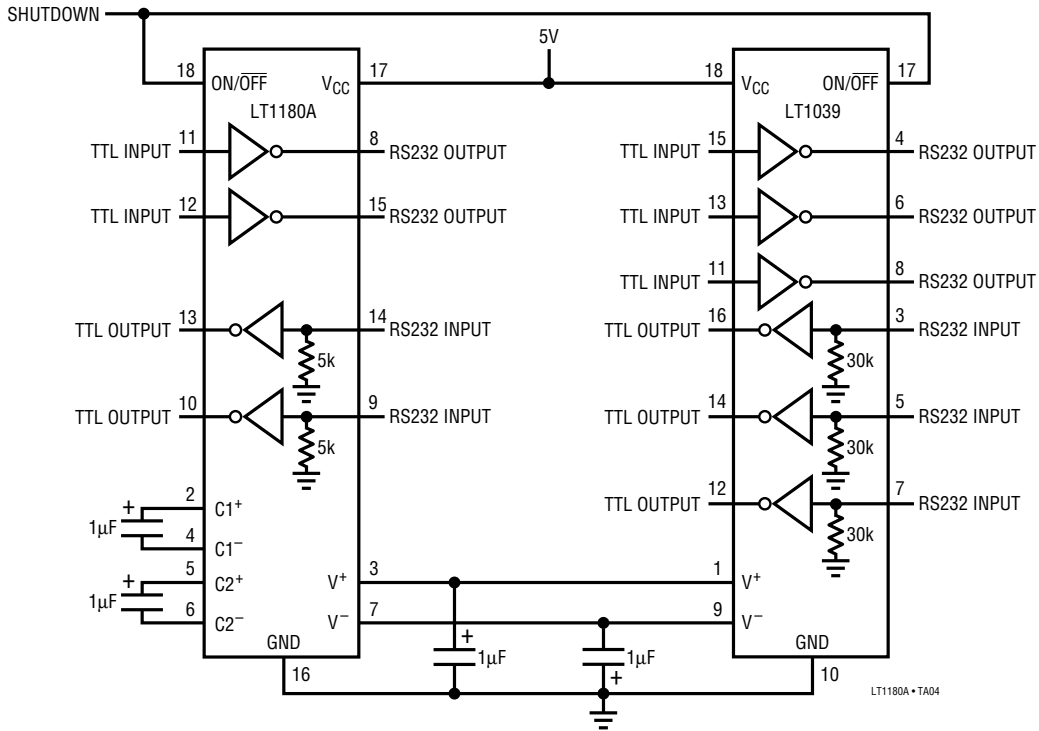

LT1180A • TA04

# PACKAGE DESCRIPTION

Dimensions in inches (millimeters) unless otherwise noted.

**N Package  
16-Lead Plastic DIP**

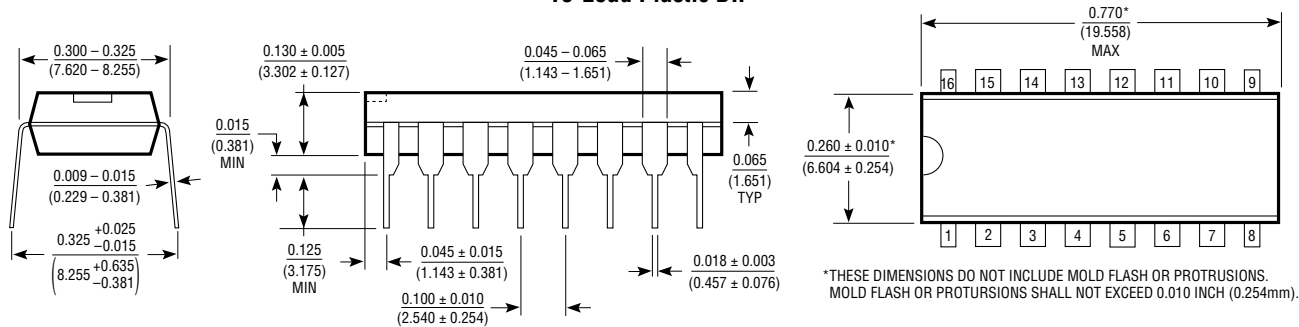

**N Package  
18-Lead Plastic DIP**

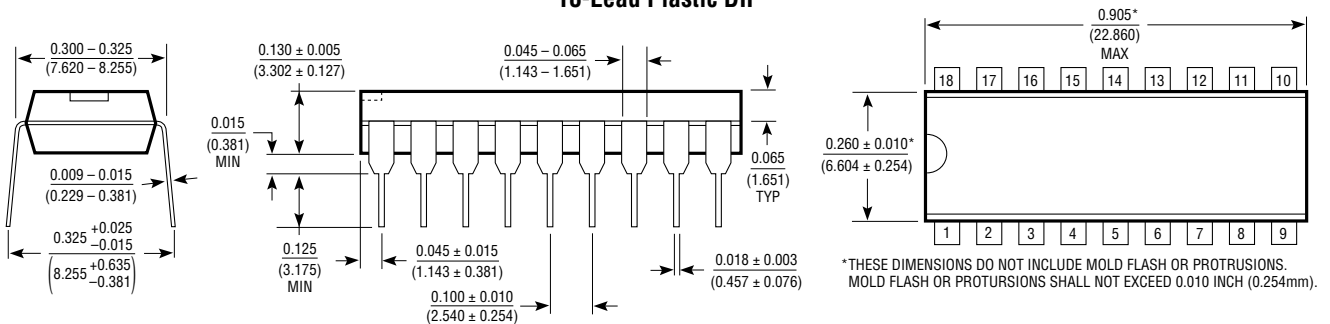

# LT1180A/LT1181A

## PACKAGE DESCRIPTION Dimensions in inches (millimeters) unless otherwise noted.

### S Package 16-Lead SOL

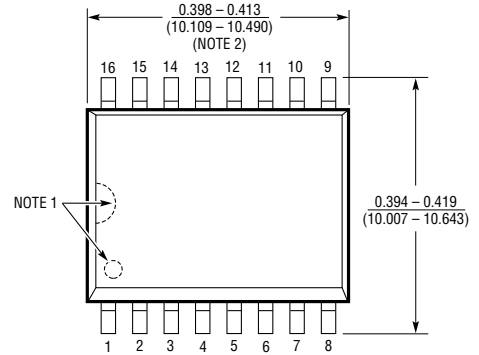
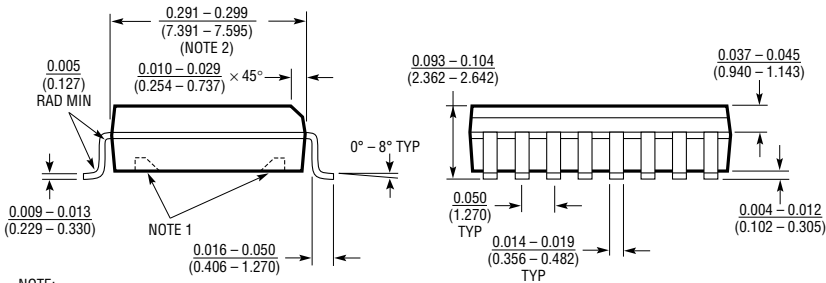

- NOTE:  
 1. PIN 1 IDENT, NOTCH ON TOP AND CAVITIES ON THE BOTTOM OF PACKAGES ARE THE MANUFACTURING OPTIONS. THE PART MAY BE SUPPLIED WITH OR WITHOUT ANY OF THE OPTIONS.  
 2. THESE DIMENSIONS DO NOT INCLUDE MOLD FLASH OR PROTRUSIONS. MOLD FLASH OR PROTRUSIONS SHALL NOT EXCEED 0.006 INCH (0.15mm).

### S Package 18-Lead SOL

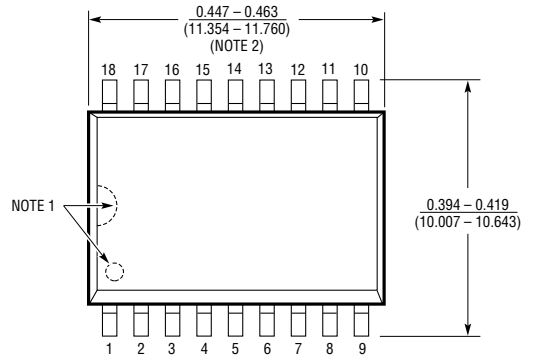
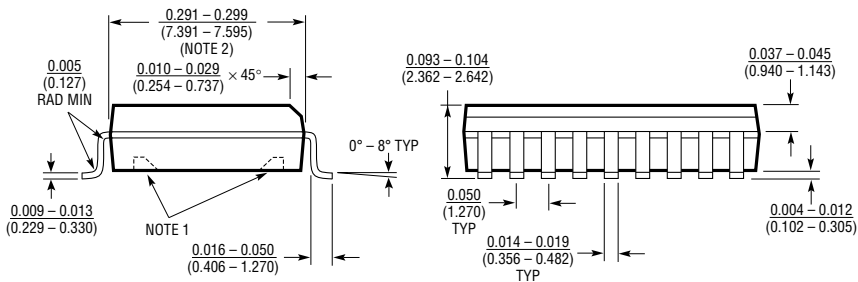

- NOTE:  
 1. PIN 1 IDENT, NOTCH ON TOP AND CAVITIES ON THE BOTTOM OF PACKAGES ARE THE MANUFACTURING OPTIONS. THE PART MAY BE SUPPLIED WITH OR WITHOUT ANY OF THE OPTIONS.  
 2. THESE DIMENSIONS DO NOT INCLUDE MOLD FLASH OR PROTRUSIONS. MOLD FLASH OR PROTRUSIONS SHALL NOT EXCEED 0.006 INCH (0.15mm).