



ADSP-2106x SHARC® DSP Microcomputer Family

ADSP-21060/ADSP-21060L

SUMMARY

High Performance Signal Processor for Communications, Graphics, and Imaging Applications
 Super Harvard Architecture
 Four Independent Buses for Dual Data Fetch, Instruction Fetch, and Nonintrusive I/O
 32-Bit IEEE Floating-Point Computation Units—Multiplier, ALU, and Shifter
 Dual-Ported On-Chip SRAM and Integrated I/O Peripherals—A Complete System-On-A-Chip
 Integrated Multiprocessing Features

KEY FEATURES

40 MIPS, 25 ns Instruction Rate, Single-Cycle Instruction Execution
 120 MFLOPS Peak, 80 MFLOPS Sustained Performance
 Dual Data Address Generators with Modulo and Bit-Reverse Addressing
 Efficient Program Sequencing with Zero-Overhead Looping: Single-Cycle Loop Setup

IEEE JTAG Standard 1149.1 Test Access Port and On-Chip Emulation

240-Lead Thermally Enhanced MQFP Package

225 PBGA Package

32-Bit Single-Precision and 40-Bit Extended-Precision IEEE Floating-Point Data Formats or 32-Bit Fixed-Point Data Format

Parallel Computations

Single-Cycle Multiply and ALU Operations in Parallel with Dual Memory Read/Writes and Instruction Fetch
 Multiply with Add and Subtract for Accelerated FFT Butterfly Computation

4 Mbit On-Chip SRAM

Dual-Ported for Independent Access by Core Processor and DMA

Off-Chip Memory Interfacing

4 Gigawords Addressable

Programmable Wait State Generation, Page-Mode DRAM Support

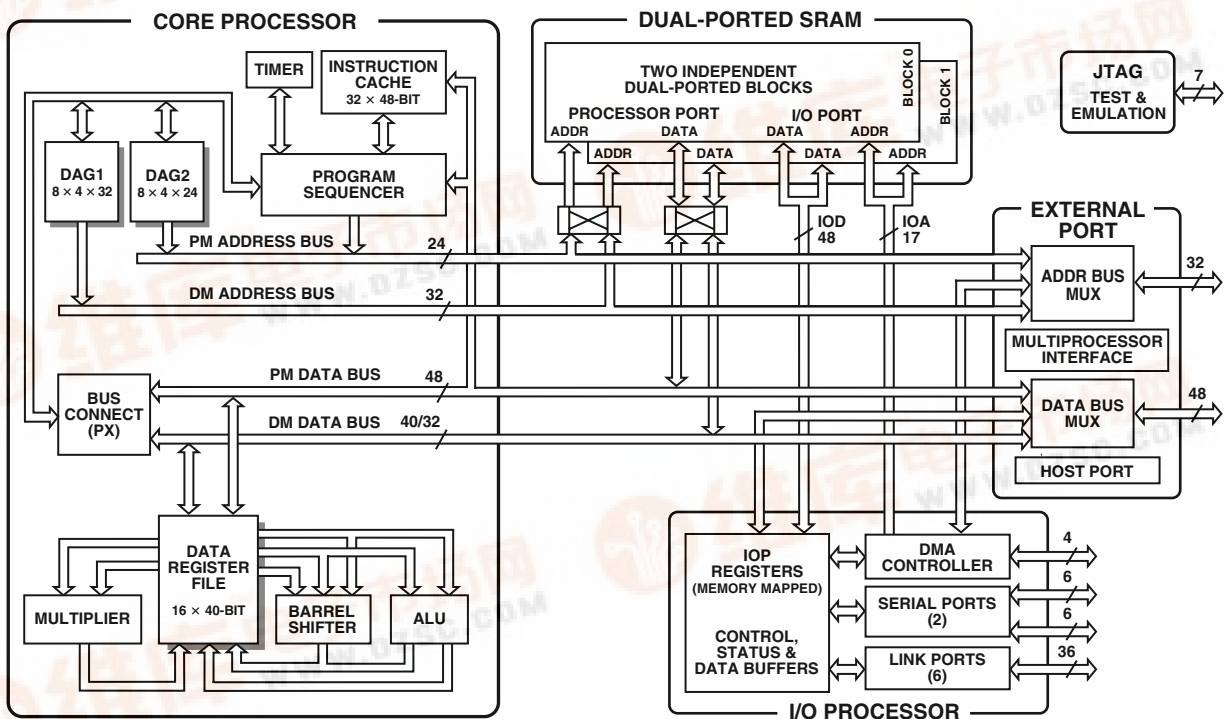

Figure 1. Block Diagram

SHARC is a registered trademark of Analog Devices, Inc.

REV. D

Information furnished by Analog Devices is believed to be accurate and reliable. However, no responsibility is assumed by Analog Devices for its use, nor for any infringements of patents or other rights of third parties which may result from its use. No license is granted by implication or otherwise under any patent or patent rights of Analog Devices.

One Technology Way, P.O. Box 9106, Norwood, MA 02062-9106, U.S.A.
 Tel: 781/329-4700
 World Wide Web Site: <http://www.analog.com>
 Fax: 781/326-8702 © Analog Devices, Inc. 2000

ADSP-21060/ADSP-21060L

DMA Controller

10 DMA Channels for Transfers Between ADSP-2106x Internal Memory and External Memory, External Peripherals, Host Processor, Serial Ports, or Link Ports

Background DMA Transfers at 40 MHz, in Parallel with Full-Speed Processor Execution

Host Processor Interface to 16- and 32-Bit Microprocessors
Host Can Directly Read/Write ADSP-2106x Internal Memory

Multiprocessing

Glueless Connection for Scalable DSP Multiprocessing Architecture

Distributed On-Chip Bus Arbitration for Parallel Bus

Connect of Up to Six ADSP-2106xs Plus Host

Six Link Ports for Point-to-Point Connectivity and Array Multiprocessing

240 Mbytes/s Transfer Rate Over Parallel Bus

240 Mbytes/s Transfer Rate Over Link Ports

Serial Ports

Two 40 Mbit/s Synchronous Serial Ports with Companding Hardware

Independent Transmit and Receive Functions

TABLE OF CONTENTS

| | |
|--------------------------------------------------------|--------|
| GENERAL DESCRIPTION | 3 |
| ADSP-21000 FAMILY CORE ARCHITECTURE | 3 |
| ADSP-21060/ADSP-21060L FEATURES | 4 |
| DEVELOPMENT TOOLS | 7 |
| PIN FUNCTION DESCRIPTIONS | 8 |
| TARGET BOARD CONNECTOR FOR EZ-ICE® | |
| PROBE | 11 |
| RECOMMENDED OPERATING CONDITIONS (5 V) | 13 |
| ELECTRICAL CHARACTERISTICS (5 V) | 13 |
| POWER DISSIPATION ADSP-21060 (5 V) | 14 |
| RECOMMENDED OPERATING CONDITIONS (3.3 V) | 15 |
| ELECTRICAL CHARACTERISTICS (3.3 V) | 15 |
| POWER DISSIPATION ADSP-21060L (3.3 V) | 16 |
| ABSOLUTE MAXIMUM RATINGS | 17 |
| TIMING SPECIFICATIONS | 17 |
| Memory Read—Bus Master | 20 |
| Memory Write—Bus Master | 21 |
| Synchronous Read/Write—Bus Master | 22 |
| Synchronous Read/Write—Bus Slave | 24 |
| Multiprocessor Bus Request and Host Bus Request | 25 |
| Asynchronous Read/Write—Host to ADSP-2106x | 27 |
| Three-State Timing—Bus Master, Bus Slave, HBR, SBTS | 29 |
| DMA Handshake | 30 |
| Link Ports: 1 × CLK Speed Operation | 32 |
| Link Ports: 2 × CLK Speed Operation | 33 |
| Serial Ports | 35 |
| JTAG Test Access Port and Emulation | 38 |
| OUTPUT DRIVE CURRENTS | 39 |
| POWER DISSIPATION | 39 |
| TEST CONDITIONS | 39 |
| ENVIRONMENTAL CONDITIONS | 42 |
| 240-LEAD MQFP PIN CONFIGURATIONS | 43 |
| PACKAGE DIMENSIONS (240-Lead MQFP) | 44 |
| 225-Ball Plastic Ball Grid Array (PBGA) | |
| Package Pinout | 45, 46 |
| PACKAGE DIMENSIONS (225-Ball Grid Array PBGA) | 47 |
| ORDERING GUIDE | 47 |

FIGURES

| | |
|---------------------------------------------------------------------------------------|----|
| Figure 1. ADSP-21060/ADSP-21060L Block Diagram | 1 |
| Figure 2. ADSP-2106x System | 4 |
| Figure 3. Shared Memory Multiprocessing System | 6 |
| Figure 4. ADSP-21060/ADSP-21060L Memory Map | 7 |
| Figure 5. Target Board Connector For ADSP-2106x EZ-ICE Emulator (Jumpers in Place) | 11 |

| | |
|-------------------------------------------------------------------------------------------------------------------------|----|
| Figure 6. JTAG Scan Path Connections for Multiple ADSP-2106x Systems | 11 |
| Figure 7. JTAG Clocktree for Multiple ADSP-2106x Systems | 12 |
| Figure 8. Clock Input | 18 |
| Figure 9. Reset | 18 |
| Figure 10. Interrupts | 18 |
| Figure 11. Timer | 19 |
| Figure 12. Flags | 19 |
| Figure 13. Memory Read—Bus Master | 20 |
| Figure 14. Memory Write—Bus Master | 21 |
| Figure 15. Synchronous Read/Write—Bus Master | 23 |
| Figure 16. Synchronous Read/Write—Bus Slave | 24 |
| Figure 17. Multiprocessor Bus Request and Host Bus Request | 26 |
| Figure 18a. Synchronous REDY Timing | 27 |
| Figure 18b. Asynchronous Read/Write—Host to ADSP-2106x | 28 |
| Figure 19a. Three-State Timing (Bus Transition Cycle, SBTS Assertion) | 29 |
| Figure 19b. Three-State Timing (Host Transition Cycle) | 29 |
| Figure 20. DMA Handshake Timing | 31 |
| Figure 21. Link Ports | 34 |
| Figure 22. Serial Ports | 36 |
| Figure 23. External Late Frame Sync | 37 |
| Figure 24. IEEE 11499.1 JTAG Test Access Port | 38 |
| Figure 25. Output Enable/Disable | 40 |
| Figure 26. Equivalent Device Loading for AC Measurements (Includes All Fixtures) | 40 |
| Figure 27. Voltage Reference Levels for AC Measurements (Except Output Enable/Disable) | 40 |
| Figure 28. ADSP-2106x Typical Drive Currents (V _{DD} = 5 V) | 41 |
| Figure 29. Typical Output Rise Time (10%–90% V _{DD}) vs. Load Capacitance (V _{DD} = 5 V) | 41 |
| Figure 30. Typical Output Rise Time (0.8 V–2.0 V) vs. Load Capacitance (V _{DD} = 5 V) | 41 |
| Figure 31. Typical Output Delay or Hold vs. Load Capacitance (at Maximum Case Temperature) (V _{DD} = 5 V) | 41 |
| Figure 32. ADSP-2106x Typical Drive Currents (V _{DD} = 3.3 V) | 41 |
| Figure 33. Typical Output Rise Time (10%–90% V _{DD}) vs. Load Capacitance (V _{DD} = 3.3 V) | 41 |
| Figure 34. Typical Output Rise Time (0.8 V–2.0 V) vs. Load Capacitance (V _{DD} = 3.3 V) | 42 |
| Figure 35. Typical Output Delay or Hold vs. Load Capacitance (at Maximum Case Temperature) (V _{DD} = 3.3 V) | 42 |

ADSP-21060/ADSP-21060L



GENERAL DESCRIPTION

The ADSP-21060 SHARC—Super Harvard Architecture Computer—is a signal processing microcomputer that offers new capabilities and levels of performance. The ADSP-2106x SHARCs are 32-bit processors optimized for high performance DSP applications. The ADSP-2106x builds on the ADSP-21000 DSP core to form a complete system-on-a-chip, adding a dual-ported on-chip SRAM and integrated I/O peripherals supported by a dedicated I/O bus.

Fabricated in a high speed, low power CMOS process, the ADSP-2106x has a 25 ns instruction cycle time and operates at 40 MIPS. With its on-chip instruction cache, the processor can execute every instruction in a single cycle. Table I shows performance benchmarks for the ADSP-2106x.

The ADSP-2106x SHARC represents a new standard of integration for signal computers, combining a high performance floating-point DSP core with integrated, on-chip system features including a 4 Mbit SRAM memory host processor interface, DMA controller, serial ports, and link port and parallel bus connectivity for glueless DSP multiprocessing.

Figure 1 shows a block diagram of the ADSP-2106x, illustrating the following architectural features:

- Computation Units (ALU, Multiplier and Shifter) with a Shared Data Register File
- Data Address Generators (DAG1, DAG2)
- Program Sequencer with Instruction Cache
- Interval Timer
- On-Chip SRAM
- External Port for Interfacing to Off-Chip Memory and Peripherals
- Host Port and Multiprocessor Interface
- DMA Controller
- Serial Ports and Link Ports
- JTAG Test Access Port

Figure 2 shows a typical single-processor system. A multi-processor system is shown in Figure 3.

Table I. ADSP-21060/ADSP-21060L Benchmarks (@ 40 MHz)

| | | |
|-------------------------------------------------------|--------------|---------------|
| 1024-Pt. Complex FFT (Radix 4, with Digit Reverse) | 0.46 ms | 18,221 cycles |
| FIR Filter (per Tap) | 25 ns | 1 cycle |
| IIR Filter (per Biquad) | 100 ns | 4 cycles |
| Divide (y/x) | 150 ns | 6 cycles |
| Inverse Square Root ($1/\sqrt{x}$) | 225 ns | 9 cycles |
| DMA Transfer Rate | 240 Mbytes/s | |

ADSP-21000 FAMILY CORE ARCHITECTURE

The ADSP-2106x includes the following architectural features of the ADSP-21000 family core. The ADSP-21060 is code- and function-compatible with the ADSP-21061 and ADSP-21062.

Independent, Parallel Computation Units

The arithmetic/logic unit (ALU), multiplier and shifter all perform single-cycle instructions. The three units are arranged in parallel, maximizing computational throughput. Single multi-function instructions execute parallel ALU and multiplier operations. These computation units support IEEE 32-bit single-precision floating-point, extended precision 40-bit floating-point, and 32-bit fixed-point data formats.

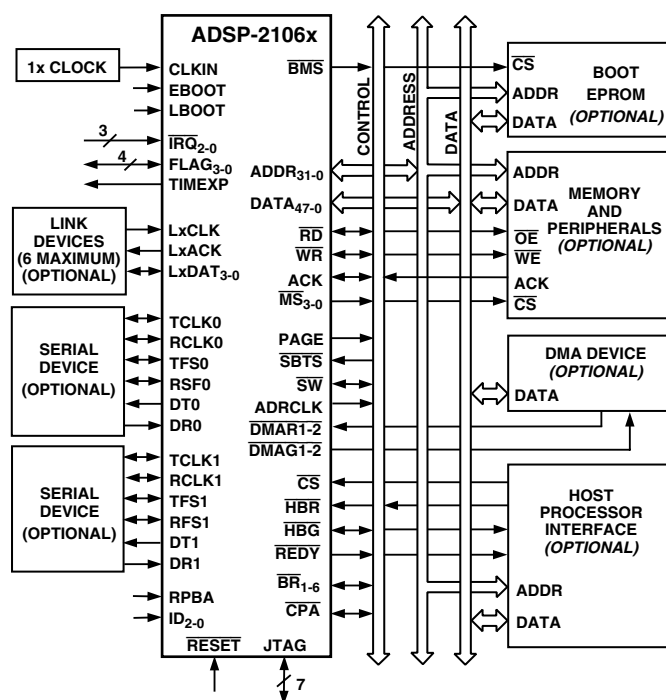

Figure 2. ADSP-2106x System

Data Register File

A general purpose data register file is used for transferring data between the computation units and the data buses, and for storing intermediate results. This 10-port, 32-register (16 primary, 16 secondary) register file, combined with the ADSP-21000 Harvard architecture, allows unconstrained data flow between computation units and internal memory.

Single-Cycle Fetch of Instruction and Two Operands

The ADSP-2106x features an enhanced Harvard architecture in which the data memory (DM) bus transfers data and the program memory (PM) bus transfers both instructions and data (see Figure 1). With its separate program and data memory buses and on-chip instruction cache, the processor can simultaneously fetch two operands and an instruction (from the cache), all in a single cycle.

ADSP-21060/ADSP-21060L

Instruction Cache

The ADSP-2106x includes an on-chip instruction cache that enables three-bus operation for fetching an instruction and two data values. The cache is selective—only the instructions whose fetches conflict with PM bus data accesses are cached. This allows full-speed execution of core, looped operations such as digital filter multiply-accumulates and FFT butterfly processing.

Data Address Generators with Hardware Circular Buffers

The ADSP-2106x's two data address generators (DAGs) implement circular data buffers in hardware. Circular buffers allow efficient programming of delay lines and other data structures required in digital signal processing, and are commonly used in digital filters and Fourier transforms. The two DAGs of the ADSP-2106x contain sufficient registers to allow the creation of up to 32 circular buffers (16 primary register sets, 16 secondary). The DAGs automatically handle address pointer wrap-around, reducing overhead, increasing performance, and simplifying implementation. Circular buffers can start and end at any memory location.

Flexible Instruction Set

The 48-bit instruction word accommodates a variety of parallel operations, for concise programming. For example, the ADSP-2106x can conditionally execute a multiply, an add, a subtract and a branch, all in a single instruction.

ADSP-21060/ADSP-21060L FEATURES

Augmenting the ADSP-21000 family core, the ADSP-21060 adds the following architectural features:

Dual-Ported On-Chip Memory

The ADSP-21060 contains four megabits of on-chip SRAM, organized as two blocks of 2 Mbits each, which can be configured for different combinations of code and data storage. Each memory block is dual-ported for single-cycle, independent accesses by the core processor and I/O processor or DMA controller. The dual-ported memory and separate on-chip buses allow two data transfers from the core and one from I/O, all in a single cycle.

On the ADSP-21060, the memory can be configured as a maximum of 128K words of 32-bit data, 256K words of 16-bit data, 80K words of 48-bit instructions (or 40-bit data), or combinations of different word sizes up to four megabits. All of the memory can be accessed as 16-bit, 32-bit, or 48-bit words.

A 16-bit floating-point storage format is supported that effectively doubles the amount of data that may be stored on-chip. Conversion between the 32-bit floating-point and 16-bit floating-point formats is done in a single instruction.

While each memory block can store combinations of code and data, accesses are most efficient when one block stores data, using the DM bus for transfers, and the other block stores instructions and data, using the PM bus for transfers. Using the DM bus and PM bus in this way, with one dedicated to each memory block, assures single-cycle execution with two data transfers. In this case, the instruction must be available in the cache. Single-cycle execution is also maintained when one of the data operands is transferred to or from off-chip, via the ADSP-2106x's external port.

Off-Chip Memory and Peripherals Interface

The ADSP-2106x's external port provides the processor's interface to off-chip memory and peripherals. The 4-gigaword off-chip address space is included in the ADSP-2106x's unified address space. The separate on-chip buses—for PM addresses, PM data, DM addresses, DM data, I/O addresses, and I/O data—are multiplexed at the external port to create an external system bus with a single 32-bit address bus and a single 48-bit (or 32-bit) data bus.

Addressing of external memory devices is facilitated by on-chip decoding of high-order address lines to generate memory bank select signals. Separate control lines are also generated for simplified addressing of page-mode DRAM. The ADSP-2106x provides programmable memory wait states and external memory acknowledge controls to allow interfacing to DRAM and peripherals with variable access, hold, and disable time requirements.

Host Processor Interface

The ADSP-2106x's host interface allows easy connection to standard microprocessor buses, both 16-bit and 32-bit, with little additional hardware required. Asynchronous transfers at speeds up to the full clock rate of the processor are supported. The host interface is accessed through the ADSP-2106x's external port and is memory-mapped into the unified address space. Four channels of DMA are available for the host interface; code and data transfers are accomplished with low software overhead.

The host processor requests the ADSP-2106x's external bus with the host bus request ($\overline{\text{HBR}}$), host bus grant ($\overline{\text{HBG}}$), and ready (REDY) signals. The host can directly read and write the internal memory of the ADSP-2106x, and can access the DMA channel setup and mailbox registers. Vector interrupt support is provided for efficient execution of host commands.

DMA Controller

The ADSP-2106x's on-chip DMA controller allows zero-overhead data transfers without processor intervention. The DMA controller operates independently and invisibly to the processor core, allowing DMA operations to occur while the core is simultaneously executing its program instructions.

DMA transfers can occur between the ADSP-2106x's internal memory and either external memory, external peripherals or a host processor. DMA transfers can also occur between the ADSP-2106x's internal memory and its serial ports or link ports. DMA transfers between external memory and external peripheral devices are another option. External bus packing to 16-, 32-, or 48-bit words is performed during DMA transfers.

Ten channels of DMA are available on the ADSP-2106x—two via the link ports, four via the serial ports, and four via the processor's external port (for either host processor, other ADSP-2106xs, memory or I/O transfers). Four additional link port DMA channels are shared with serial port 1 and the external port. Programs can be downloaded to the ADSP-2106x using DMA transfers. Asynchronous off-chip peripherals can control two DMA channels using DMA Request/Grant lines ($\overline{\text{DMARI-2}}$, $\overline{\text{DMAGI-2}}$). Other DMA features include interrupt generation upon completion of DMA transfers and DMA chaining for automatic linked DMA transfers.

Serial Ports

The ADSP-2106x features two synchronous serial ports that provide an inexpensive interface to a wide variety of digital and mixed-signal peripheral devices. The serial ports can operate at the full clock rate of the processor, providing each with a maximum data rate of 40 Mbit/s. Independent transmit and receive functions provide greater flexibility for serial communications. Serial port data can be automatically transferred to and from on-chip memory via DMA. Each of the serial ports offers TDM multichannel mode.

The serial ports can operate with little-endian or big-endian transmission formats, with word lengths selectable from 3 bits to 32 bits. They offer selectable synchronization and transmit modes as well as optional μ -law or A-law companding. Serial port clocks and frame syncs can be internally or externally generated.

Multiprocessing

The ADSP-2106x offers powerful features tailored to multiprocessing DSP systems. The unified address space (see Figure 4) allows direct interprocessor accesses of each ADSP-2106x's internal memory. Distributed bus arbitration logic is included on-chip for simple, glueless connection of systems containing up to six ADSP-2106xs and a host processor. Master processor changeover incurs only one cycle of overhead. Bus arbitration is selectable as either fixed or rotating priority. Bus lock allows indivisible *read-modify-write* sequences for semaphores. A vector interrupt is provided for interprocessor commands. Maximum throughput for interprocessor data transfer is 240 Mbytes/s over the link ports or external port. *Broadcast writes* allow simultaneous transmission of data to all ADSP-2106xs and can be used to implement reflective semaphores.

Link Ports

The ADSP-2106x features six 4-bit link ports that provide additional I/O capabilities. The link ports can be clocked twice per cycle, allowing each to transfer eight bits per cycle. Link port I/O is especially useful for point-to-point interprocessor communication in multiprocessing systems.

The link ports can operate independently and simultaneously, with a maximum data throughput of 240 Mbytes/s. Link port data is packed into 32- or 48-bit words, and can be directly read by the core processor or DMA-transferred to on-chip memory.

Each link port has its own double-buffered input and output registers. Clock/acknowledge handshaking controls link port transfers. Transfers are programmable as either transmit or receive.

Program Booting

The internal memory of the ADSP-2106x can be booted at system power-up from either an 8-bit EPROM, a host processor, or through one of the link ports. Selection of the boot source is controlled by the BMS (Boot Memory Select), EBOOT (EPROM Boot), and LBOOT (Link/Host Boot) pins. 32-bit and 16-bit host processors can be used for booting.

ADSP-21060/ADSP-21060L

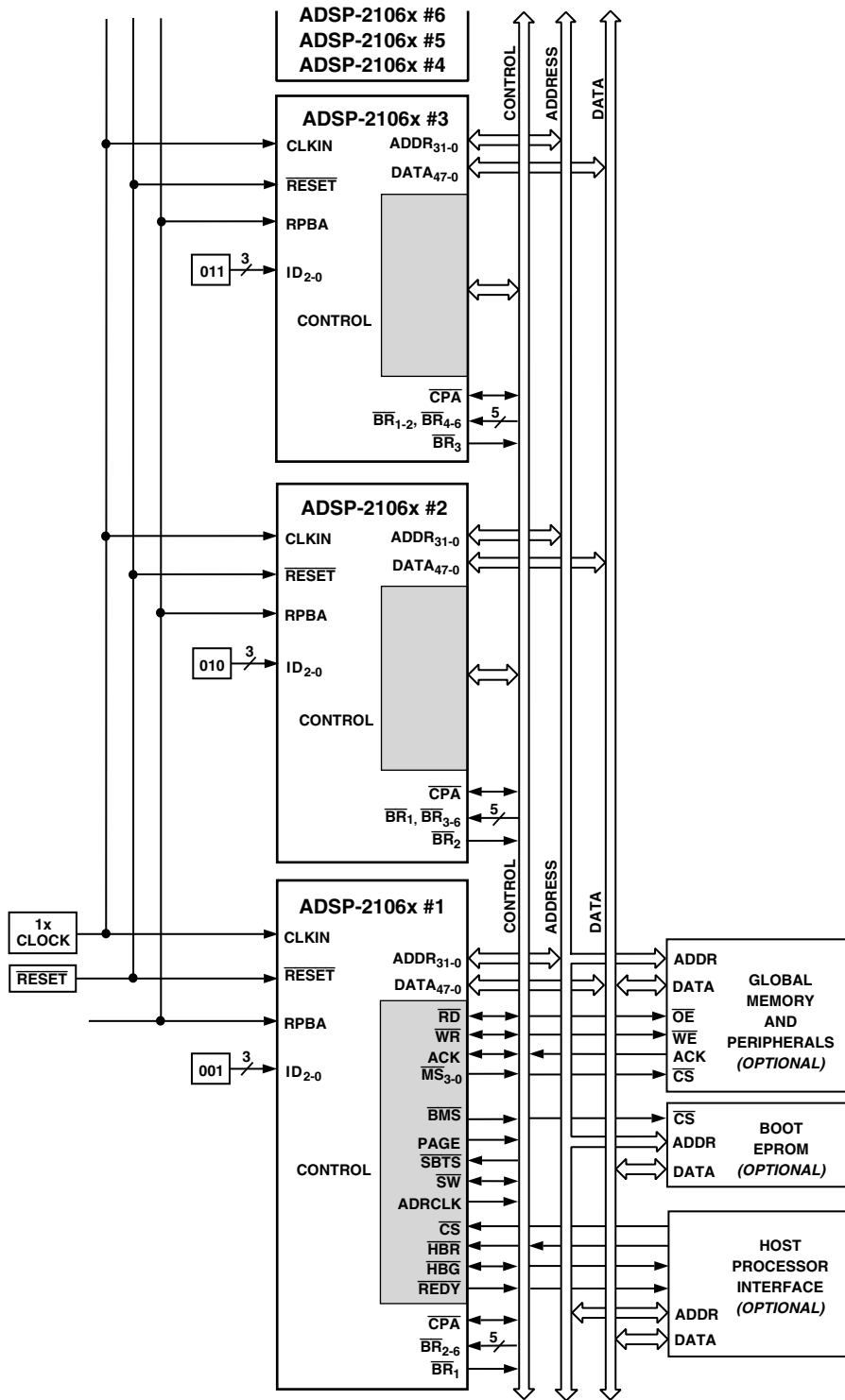

Figure 3. Shared Memory Multiprocessing System

ADSP-21060/ADSP-21060L

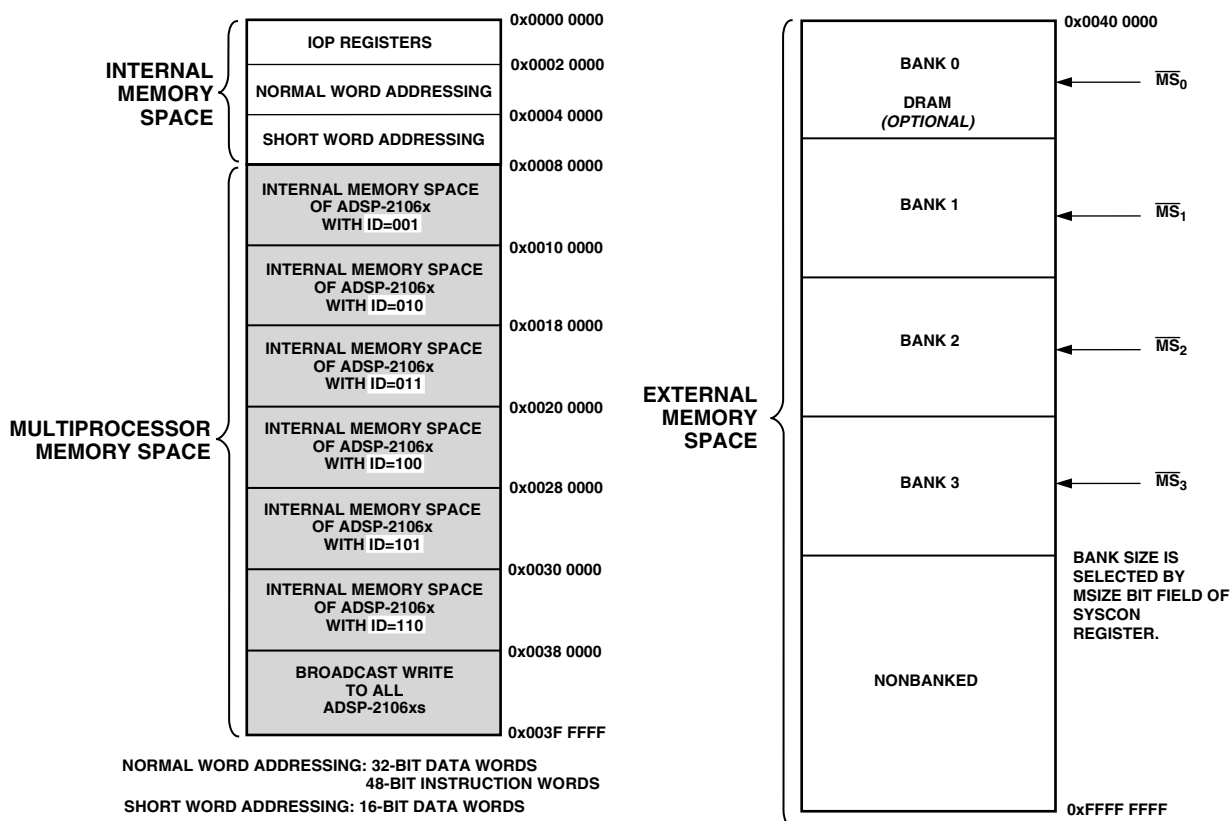

Figure 4. ADSP-21060/ADSP-21060L Memory Map

DEVELOPMENT TOOLS

The ADSP-21060 is supported with a complete set of software and hardware development tools, including an EZ-ICE In-Circuit Emulator, EZ-Kit, and development software. The SHARC EZ-Kit is a complete low cost package for DSP evaluation and prototyping. The EZ-Kit contains a PC plug-in card (EZ-LAB[®]) with an ADSP-21062 (5 V) processor. The EZ-Kit also includes an optimizing compiler, assembler, instruction level simulator, run-time libraries, diagnostic utilities and a complete set of example programs.

The same EZ-ICE hardware can be used for the ADSP-21061/ADSP-21062, to fully emulate the ADSP-21060, with the exception of displaying and modifying the two new SPORTS registers unique to ADSP-21061.

Analog Devices ADSP-21000 Family Development Software includes an easy to use Assembler based on an algebraic syntax, Assembly Library/Librarian, Linker, instruction-level Simulator, an ANSI C optimizing Compiler, the CBUG[™] C Source—Level Debugger and a C Runtime Library including DSP and mathematical functions. The Optimizing Compiler includes Numerical C extensions based on the work of the ANSI Numerical C Extensions Group. Numerical C provides extensions to the C language for array selections, vector math operations, complex data types, circular pointers and variably dimensioned

arrays. The ADSP-21000 Family Development Software is available for both the PC and Sun platforms.

The ADSP-21060 EZ-ICE Emulator uses the IEEE 1149.1 JTAG test access port of the ADSP-21060 processor to monitor and control the target board processor during emulation. The EZ-ICE provides full-speed emulation, allowing inspection and modification of memory, registers, and processor stacks. Nonintrusive in-circuit emulation is assured by the use of the processor's JTAG interface—the emulator does not affect target system loading or timing.

Further details and ordering information are available in the *ADSP-21000 Family Hardware and Software Development Tools* data sheet (ADDS-210xx-TOOLS). This data sheet can be requested from any Analog Devices sales office or distributor.

In addition to the software and hardware development tools available from Analog Devices, third parties provide a wide range of tools supporting the SHARC processor family. Hardware tools include SHARC PC plug-in cards multiprocessor SHARC VME boards, and daughter and modules with multiple SHARCs and additional memory. These modules are based on the SHARCPAC[™] module specification. Third Party software tools include an Ada compiler, DSP libraries, operating systems and block diagram design tools.

ADDITIONAL INFORMATION

This data sheet provides a general overview of the ADSP-21060 architecture and functionality. For detailed information on the ADSP-21000 Family core architecture and instruction set, refer to the *ADSP-2106x SHARC User's Manual*, Second Edition.

ADSP-21060/ADSP-21060L

PIN FUNCTION DESCRIPTIONS

ADSP-21060 pin definitions are listed below. All pins are identical on the ADSP-21060 and ADSP-21060L. Inputs identified as synchronous (S) must meet timing requirements with respect to CLKIN (or with respect to TCK for TMS, TDI). Inputs identified as asynchronous (A) can be asserted asynchronously to CLKIN (or to TCK for $\overline{\text{TRST}}$).

Unused inputs should be tied or pulled to VDD or GND, except for ADDR₃₁₋₀, DATA₄₇₋₀, FLAG₃₋₀, $\overline{\text{SW}}$, and inputs that have internal pull-up or pull-down resistors ($\overline{\text{CPA}}$, ACK, DTx,

DRx, TCLKx, RCLKx, LxDAT₃₋₀, LxCLK, LxACK, TMS and TDI)—these pins can be left floating. These pins have a logic-level hold circuit that prevents the input from floating internally.

A = Asynchronous G = Ground I = Input
 O = Output P = Power Supply S = Synchronous
 (A/D) = Active Drive (O/D) = Open Drain
 T = Three-State (when $\overline{\text{SBTS}}$ is asserted, or when the ADSP-2106x is a bus slave)

| Pin | Type | Function |
|------------------------------|-------|-------------------------------------------------------------------------------------------------------------------------------------------------------------------------------------------------------------------------------------------------------------------------------------------------------------------------------------------------------------------------------------------------------------------------------------------------------------------------------------------------------------------------------------------------------------------------------------------------------------------------------------------------------------------------------------------------------------------------------------------------------------------------------------|
| ADDR ₃₁₋₀ | I/O/T | External Bus Address. The ADSP-2106x outputs addresses for external memory and peripherals on these pins. In a multiprocessor system the bus master outputs addresses for read/writes of the internal memory or IOP registers of other ADSP-2106xs. The ADSP-2106x inputs addresses when a host processor or multiprocessing bus master is reading or writing its internal memory or IOP registers. |
| DATA ₄₇₋₀ | I/O/T | External Bus Data. The ADSP-2106x inputs and outputs data and instructions on these pins. 32-bit single-precision floating-point data and 32-bit fixed-point data is transferred over bits 47–16 of the bus. 40-bit extended-precision floating-point data is transferred over bits 47–8 of the bus. 16-bit short word data is transferred over bits 31–16 of the bus. In PROM boot mode, 8-bit data is transferred over bits 23–16. Pull-up resistors on unused DATA pins are not necessary. |
| $\overline{\text{MS}}_{3-0}$ | O/T | Memory Select Lines. These lines are asserted (low) as chip selects for the corresponding banks of external memory. Memory bank size must be defined in the ADSP-2106x's system control register (SYSCON). The $\overline{\text{MS}}_{3-0}$ lines are decoded memory address lines that change at the same time as the other address lines. When no external memory access is occurring the $\overline{\text{MS}}_{3-0}$ lines are inactive; they are active however when a conditional memory access instruction is executed, whether or not the condition is true. $\overline{\text{MS}}_0$ can be used with the PAGE signal to implement a bank of DRAM memory (Bank 0). In a multiprocessing system the $\overline{\text{MS}}_{3-0}$ lines are output by the bus master. |
| $\overline{\text{RD}}$ | I/O/T | Memory Read Strobe. This pin is asserted (low) when the ADSP-2106x reads from external memory devices or from the internal memory of other ADSP-2106xs. External devices (including other ADSP-2106xs) must assert $\overline{\text{RD}}$ to read from the ADSP-2106x's internal memory. In a multiprocessing system $\overline{\text{RD}}$ is output by the bus master and is input by all other ADSP-2106xs. |
| $\overline{\text{WR}}$ | I/O/T | Memory Write Strobe. This pin is asserted (low) when the ADSP-2106x writes to external memory devices or to the internal memory of other ADSP-2106xs. External devices must assert $\overline{\text{WR}}$ to write to the ADSP-2106x's internal memory. In a multiprocessing system $\overline{\text{WR}}$ is output by the bus master and is input by all other ADSP-2106xs. |
| PAGE | O/T | DRAM Page Boundary. The ADSP-2106x asserts this pin to signal that an external DRAM page boundary has been crossed. DRAM page size must be defined in the ADSP-2106x's memory control register (WAIT). DRAM can only be implemented in external memory Bank 0; the PAGE signal can only be activated for Bank 0 accesses. In a multiprocessing system PAGE is output by the bus master. |
| ADRCLK | O/T | Clock Output Reference. In a multiprocessing system ADRCLK is output by the bus master. |
| $\overline{\text{SW}}$ | I/O/T | Synchronous Write Select. This signal is used to interface the ADSP-2106x to synchronous memory devices (including other ADSP-2106xs). The ADSP-2106x asserts $\overline{\text{SW}}$ (low) to provide an early indication of an impending write cycle, which can be aborted if $\overline{\text{WR}}$ is not later asserted (e.g., in a conditional write instruction). In a multiprocessing system, $\overline{\text{SW}}$ is output by the bus master and is input by all other ADSP-2106xs to determine if the multiprocessor memory access is a read or write. $\overline{\text{SW}}$ is asserted at the same time as the address output. A host processor using synchronous writes must assert this pin when writing to the ADSP-2106x(s). |
| ACK | I/O/S | Memory Acknowledge. External devices can deassert ACK (low) to add wait states to an external memory access. ACK is used by I/O devices, memory controllers, or other peripherals to hold off completion of an external memory access. The ADSP-2106x deasserts ACK as an output to add wait states to a synchronous access of its internal memory. In a multiprocessing system, a slave ADSP-2106x deasserts the bus master's ACK input to add wait state(s) to an access of its internal memory. The bus master has a keeper latch on its ACK pin that maintains the input at the level it was last driven to. |

ADSP-21060/ADSP-21060L

| Pin | Type | Function |
|-------------------------------|-------|----------------------------------------------------------------------------------------------------------------------------------------------------------------------------------------------------------------------------------------------------------------------------------------------------------------------------------------------------------------------------------------------------------------------------------------------------------------------------------------------------------------------------------------------------------------|
| $\overline{\text{SBTS}}$ | I/S | Suspend Bus Three-State. External devices can assert $\overline{\text{SBTS}}$ (low) to place the external bus address, data, selects and strobes in a high impedance state for the following cycle. If the ADSP-2106x attempts to access external memory while $\overline{\text{SBTS}}$ is asserted, the processor will halt and the memory access will not be completed until $\overline{\text{SBTS}}$ is deasserted. $\overline{\text{SBTS}}$ should only be used to recover from host processor/ADSP-2106x deadlock, or used with a DRAM controller. |
| $\overline{\text{IRQ}}_{2-0}$ | I/A | Interrupt Request Lines. May be either edge-triggered or level-sensitive. |
| FLAG_{3-0} | I/O/A | Flag Pins. Each is configured via control bits as either an input or output. As an input, it can be tested as a condition. As an output, it can be used to signal external peripherals. |
| TIMEXP | O | Timer Expired. Asserted for four cycles when the timer is enabled and TCOUNT decrements to zero. |
| $\overline{\text{HBR}}$ | I/A | Host Bus Request. Must be asserted by a host processor to request control of the ADSP-2106x's external bus. When $\overline{\text{HBR}}$ is asserted in a multiprocessing system, the ADSP-2106x that is bus master will relinquish the bus and assert $\overline{\text{HBG}}$. To relinquish the bus, the ADSP-2106x places the address, data, select and strobe lines in a high impedance state. $\overline{\text{HBR}}$ has priority over all ADSP-2106x bus requests ($\overline{\text{BR}}_{6-1}$) in a multiprocessing system. |
| $\overline{\text{HBG}}$ | I/O | Host Bus Grant. Acknowledges an $\overline{\text{HBR}}$ bus request, indicating that the host processor may take control of the external bus. $\overline{\text{HBG}}$ is asserted (held low) by the ADSP-2106x until $\overline{\text{HBR}}$ is released. In a multiprocessing system, $\overline{\text{HBG}}$ is output by the ADSP-2106x bus master and is monitored by all others. |
| $\overline{\text{CS}}$ | I/A | Chip Select. Asserted by host processor to select the ADSP-2106x. |
| REDY (O/D) | O | Host Bus Acknowledge. The ADSP-2106x deasserts REDY (low) to add wait states to an asynchronous access of its internal memory or IOP registers by a host. Open drain output (O/D) by default; can be programmed in ADREDY bit of SYSCON register to be active drive (A/D). REDY will only be output if the $\overline{\text{CS}}$ and $\overline{\text{HBR}}$ inputs are asserted. |
| $\overline{\text{DMAR}}_1$ | I/A | DMA Request 1 (DMA Channel 7). |
| $\overline{\text{DMAR}}_2$ | I/A | DMA Request 2 (DMA Channel 8). |
| $\overline{\text{DMAG}}_1$ | O/T | DMA Grant 1 (DMA Channel 7). |
| $\overline{\text{DMAG}}_2$ | O/T | DMA Grant 2 (DMA Channel 8). |
| $\overline{\text{BR}}_{6-1}$ | I/O/S | Multiprocessing Bus Requests. Used by multiprocessing ADSP-2106xs to arbitrate for bus master-ship. An ADSP-2106x only drives its own $\overline{\text{BR}}_x$ line (corresponding to the value of its ID_{2-0} inputs) and monitors all others. In a multiprocessor system with less than six ADSP-2106xs, the unused $\overline{\text{BR}}_x$ pins should be pulled high; the processor's own $\overline{\text{BR}}_x$ line must not be pulled high or low because it is an output. |
| ID_{2-0} | I | Multiprocessing ID. Determines which multiprocessing bus request ($\overline{\text{BR}}_1 - \overline{\text{BR}}_6$) is used by ADSP-2106x. ID = 001 corresponds to $\overline{\text{BR}}_1$, ID = 010 corresponds to $\overline{\text{BR}}_2$, etc. ID = 000 in single-processor systems. These lines are a system configuration selection which should be hardwired or only changed at reset. |
| RPBA | I/S | Rotating Priority Bus Arbitration Select. When RPBA is high, rotating priority for multiprocessor bus arbitration is selected. When RPBA is low, fixed priority is selected. This signal is a system configuration selection which must be set to the same value on every ADSP-2106x. If the value of RPBA is changed during system operation, it must be changed in the same CLKIN cycle on every ADSP-2106x. |
| $\overline{\text{CPA}}$ (O/D) | I/O | Core Priority Access. Asserting its $\overline{\text{CPA}}$ pin allows the core processor of an ADSP-2106x bus slave to interrupt background DMA transfers and gain access to the external bus. $\overline{\text{CPA}}$ is an open drain output that is connected to all ADSP-2106xs in the system. The $\overline{\text{CPA}}$ pin has an internal 5 k Ω pull-up resistor. If core access priority is not required in a system, the $\overline{\text{CPA}}$ pin should be left unconnected. |
| DTx | O | Data Transmit (Serial Ports 0, 1). Each DT pin has a 50 k Ω internal pull-up resistor. |
| DRx | I | Data Receive (Serial Ports 0, 1). Each DR pin has a 50 k Ω internal pull-up resistor. |
| TCLKx | I/O | Transmit Clock (Serial Ports 0, 1). Each TCLK pin has a 50 k Ω internal pull-up resistor. |
| RCLKx | I/O | Receive Clock (Serial Ports 0, 1). Each RCLK pin has a 50 k Ω internal pull-up resistor. |

ADSP-21060/ADSP-21060L

| Pin | Type | Function | | | | | | | | | | | | | | | | | | | | | | | | | | | | |
|-------------------------------|--------------|------------------------------------------------------------------------------------------------------------------------------------------------------------------------------------------------------------------------------------------------------------------------------------------------------------------------------------------------------------------------------------------------------------------------------------------------------------------------------------------------------------------------------------------------------------------------------------------------------------------------------------------------------------------------------------------------------------------------------------------------------------------------------------------------------------------------------------------------------------------------------------------------------------------------------------------------------------------------------------------------------------------------------------------------------------------------------------------------------------------------------------------------------------------------------------------------------------------------------------------------------------------------------------------------------------------|---------------------------------------------------------------|--------------|-------------------------|---------------------|---|---|--------|---------------------------------------------------------------|---|---|-----------|----------------|---|---|-----------|-----------|---|---|-----------|------------------------------------------------------|---|---|-----------|----------|---|---|-----------|----------|
| TFSx | I/O | Transmit Frame Sync (Serial Ports 0, 1). | | | | | | | | | | | | | | | | | | | | | | | | | | | | |
| RFSx | I/O | Receive Frame Sync (Serial Ports 0, 1). | | | | | | | | | | | | | | | | | | | | | | | | | | | | |
| LxDAT ₃₋₀ | I/O | Link Port Data (Link Ports 0–5). Each LxCLK pin has a 50 kΩ internal pull-down resistor that is enabled or disabled by the LPDRD bit of the LCOM register. | | | | | | | | | | | | | | | | | | | | | | | | | | | | |
| LxCLK | I/O | Link Port Clock (Link Ports 0–5). Each LxCLK pin has a 50 kΩ internal pull-down resistor that is enabled or disabled by the LPDRD bit of the LCOM register. | | | | | | | | | | | | | | | | | | | | | | | | | | | | |
| LxACK | I/O | Link Port Acknowledge (Link Ports 0–5). Each LxACK pin has a 50 kΩ internal pull-down resistor that is enabled or disabled by the LPDRD bit of the LCOM register. | | | | | | | | | | | | | | | | | | | | | | | | | | | | |
| EBOOT | I | EPROM Boot Select. When EBOOT is high, the ADSP-2106x is configured for booting from an 8-bit EPROM. When EBOOT is low, the LBOOT and $\overline{\text{BMS}}$ inputs determine booting mode. See table below. This signal is a system configuration selection that should be hardwired. | | | | | | | | | | | | | | | | | | | | | | | | | | | | |
| LBOOT | I | Link Boot. When LBOOT is high, the ADSP-2106x is configured for link port booting. When LBOOT is low, the ADSP-2106x is configured for host processor booting or no booting. See table below. This signal is a system configuration selection that should be hardwired. | | | | | | | | | | | | | | | | | | | | | | | | | | | | |
| $\overline{\text{BMS}}$ | I/O/T* | <p>Boot Memory Select. <i>Output:</i> Used as chip select for boot EPROM devices (when EBOOT = 1, LBOOT = 0). In a multiprocessor system, $\overline{\text{BMS}}$ is output by the bus master. <i>Input:</i> When low, indicates that no booting will occur and that ADSP-2106x will begin executing instructions from external memory. See table below. This input is a system configuration selection that should be hardwired.</p> <p>*Three-statable only in EPROM boot mode (when $\overline{\text{BMS}}$ is an output).</p> <table border="1"> <thead> <tr> <th><i>EBOOT</i></th> <th><i>LBOOT</i></th> <th>$\overline{\text{BMS}}$</th> <th><i>Booting Mode</i></th> </tr> </thead> <tbody> <tr> <td>1</td> <td>0</td> <td>Output</td> <td>EPROM (Connect $\overline{\text{BMS}}$ to EPROM chip select.)</td> </tr> <tr> <td>0</td> <td>0</td> <td>1 (Input)</td> <td>Host Processor</td> </tr> <tr> <td>0</td> <td>1</td> <td>1 (Input)</td> <td>Link Port</td> </tr> <tr> <td>0</td> <td>0</td> <td>0 (Input)</td> <td>No Booting. Processor executes from external memory.</td> </tr> <tr> <td>0</td> <td>1</td> <td>0 (Input)</td> <td>Reserved</td> </tr> <tr> <td>1</td> <td>1</td> <td>x (Input)</td> <td>Reserved</td> </tr> </tbody> </table> | <i>EBOOT</i> | <i>LBOOT</i> | $\overline{\text{BMS}}$ | <i>Booting Mode</i> | 1 | 0 | Output | EPROM (Connect $\overline{\text{BMS}}$ to EPROM chip select.) | 0 | 0 | 1 (Input) | Host Processor | 0 | 1 | 1 (Input) | Link Port | 0 | 0 | 0 (Input) | No Booting. Processor executes from external memory. | 0 | 1 | 0 (Input) | Reserved | 1 | 1 | x (Input) | Reserved |
| <i>EBOOT</i> | <i>LBOOT</i> | $\overline{\text{BMS}}$ | <i>Booting Mode</i> | | | | | | | | | | | | | | | | | | | | | | | | | | | |
| 1 | 0 | Output | EPROM (Connect $\overline{\text{BMS}}$ to EPROM chip select.) | | | | | | | | | | | | | | | | | | | | | | | | | | | |
| 0 | 0 | 1 (Input) | Host Processor | | | | | | | | | | | | | | | | | | | | | | | | | | | |
| 0 | 1 | 1 (Input) | Link Port | | | | | | | | | | | | | | | | | | | | | | | | | | | |
| 0 | 0 | 0 (Input) | No Booting. Processor executes from external memory. | | | | | | | | | | | | | | | | | | | | | | | | | | | |
| 0 | 1 | 0 (Input) | Reserved | | | | | | | | | | | | | | | | | | | | | | | | | | | |
| 1 | 1 | x (Input) | Reserved | | | | | | | | | | | | | | | | | | | | | | | | | | | |
| CLKIN | I | Clock In. External clock input to the ADSP-2106x. The instruction cycle rate is equal to CLKIN. CLKIN may not be halted, changed, or operated below the minimum specified frequency. | | | | | | | | | | | | | | | | | | | | | | | | | | | | |
| $\overline{\text{RESET}}$ | I/A | Processor Reset. Resets the ADSP-2106x to a known state and begins execution at the program memory location specified by the hardware reset vector address. This input must be asserted (low) at power-up. | | | | | | | | | | | | | | | | | | | | | | | | | | | | |
| TCK | I | Test Clock (JTAG). Provides an asynchronous clock for JTAG boundary scan. | | | | | | | | | | | | | | | | | | | | | | | | | | | | |
| TMS | I/S | Test Mode Select (JTAG). Used to control the test state machine. TMS has a 20 kΩ internal pull-up resistor. | | | | | | | | | | | | | | | | | | | | | | | | | | | | |
| TDI | I/S | Test Data Input (JTAG). Provides serial data for the boundary scan logic. TDI has a 20 kΩ internal pull-up resistor. | | | | | | | | | | | | | | | | | | | | | | | | | | | | |
| TDO | O | Test Data Output (JTAG). Serial scan output of the boundary scan path. | | | | | | | | | | | | | | | | | | | | | | | | | | | | |
| $\overline{\text{TRST}}$ | I/A | Test Reset (JTAG). Resets the test state machine. $\overline{\text{TRST}}$ must be asserted (pulsed low) after power-up or held low for proper operation of the ADSP-2106x. $\overline{\text{TRST}}$ has a 20 kΩ internal pull-up resistor. | | | | | | | | | | | | | | | | | | | | | | | | | | | | |
| $\overline{\text{EMU}}$ (O/D) | O | Emulation Status. Must be connected to the ADSP-2106x EZ-ICE target board connector <i>only</i> . | | | | | | | | | | | | | | | | | | | | | | | | | | | | |
| ICSA | O | Reserved, leave unconnected. | | | | | | | | | | | | | | | | | | | | | | | | | | | | |
| VDD | P | Power Supply; nominally +5.0 V dc for 5 V devices or +3.3 V dc for 3.3 V devices. (30 pins). | | | | | | | | | | | | | | | | | | | | | | | | | | | | |
| GND | G | Power Supply Return. (30 pins). | | | | | | | | | | | | | | | | | | | | | | | | | | | | |
| NC | | Do Not Connect. Reserved pins which must be left open and unconnected. | | | | | | | | | | | | | | | | | | | | | | | | | | | | |

ADSP-21060/ADSP-21060L

TARGET BOARD CONNECTOR FOR EZ-ICE PROBE

The ADSP-2106x EZ-ICE Emulator uses the IEEE 1149.1 JTAG test access port of the ADSP-2106x to monitor and control the target board processor during emulation. The EZ-ICE probe requires the ADSP-2106x's CLKIN, TMS, TCK, TRST, TDI, TDO, EMU, and GND signals be made accessible on the target system via a 14-pin connector (a 2 row x 7 pin strip header) such as that shown in Figure 5. The EZ-ICE probe plugs directly onto this connector for chip-on-board emulation. You must add this connector to your target board design if you intend to use the ADSP-2106x EZ-ICE. The total trace length between the EZ-ICE connector and the furthest device sharing the EZ-ICE JTAG pins should be limited to 15 inches maximum for guaranteed operation. This length restriction must include EZ-ICE JTAG signals that are routed to one or more ADSP-2106x devices, or a combination of ADSP-2106x devices and other JTAG devices on the chain.

The 14-pin, 2-row pin strip header is keyed at the Pin 3 location — Pin 3 must be removed from the header. The pins must be 0.025 inch square and at least 0.20 inch in length. Pin spacing should be 0.1 x 0.1 inches. Pin strip headers are available from vendors such as 3M, McKenzie and Samtec.

The BTMS, BTCK, BTRST and BTDI signals are provided so the test access port can also be used for board-level testing. When the connector is not being used for emulation, place jumpers between the Bxxx pins and the xxx pins. If the test access port will not be used for board testing, tie BTRST to GND and tie or pull BTCK up to VDD. The TRST pin must be asserted after power-up (through BTRST on the connector) or held low for proper operation of the ADSP-2106x. None of the Bxxx pins (Pins 5, 7, 9, 11) are connected on the EZ-ICE probe.

The JTAG signals are terminated on the EZ-ICE probe as follows:

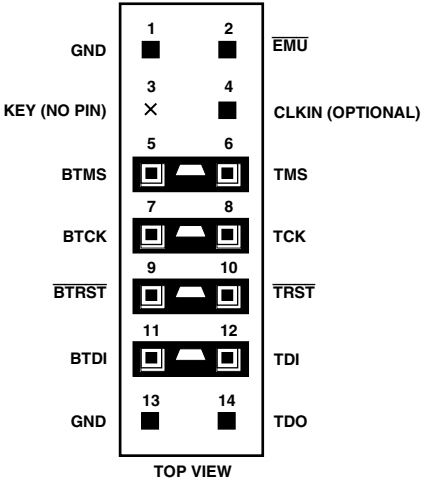

| Signal | Termination |
|--------|----------------------------------------------------------------------------------------------|
| TMS | Driven through 22 Ω Resistor (16 mA Driver) |
| TCK | Driven at 10 MHz through 22 Ω Resistor (16 mA Driver) |
| TRST* | Active Low Driven through 22 Ω Resistor (16 mA Driver) (Pulled Up by On-Chip 20 kΩ Resistor) |
| TDI | Driven by 22 Ω Resistor (16 mA Driver) |
| TDO | One TTL Load, Split Termination (160/220) |
| CLKIN | One TTL Load, Split Termination (160/220) |
| EMU | Active Low 4.7 kΩ Pull-Up Resistor, One TTL Load (Open-Drain Output from the DSP) |

*TRST is driven low until the EZ-ICE probe is turned on by the emulator at software start-up. After software start-up, TRST is driven high.

Figure 6 shows JTAG scan path connections for systems that contain multiple ADSP-2106x processors.

Figure 5. Target Board Connector For ADSP-2106x EZ-ICE Emulator (Jumpers in Place)

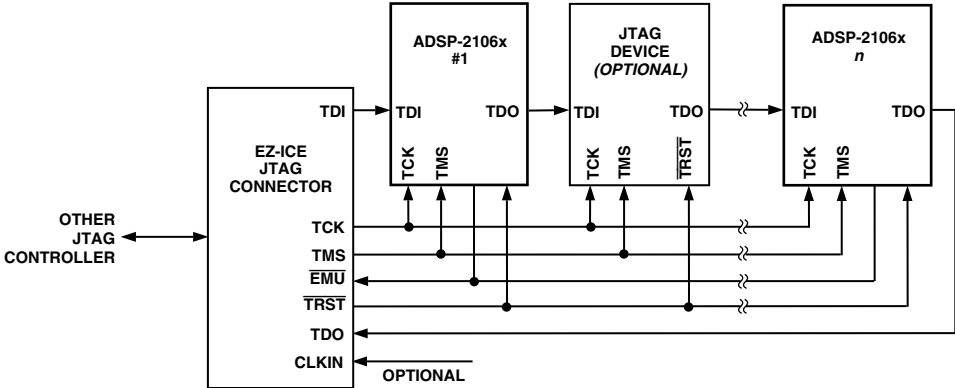

Figure 6. JTAG Scan Path Connections for Multiple ADSP-2106x Systems

ADSP-21060/ADSP-21060L

Connecting CLKIN to Pin 4 of the EZ-ICE header is optional. The emulator only uses CLKIN when directed to perform operations such as starting, stopping and single-stepping multiple ADSP-21061 in a *synchronous* manner. If you do not need these operations to occur synchronously on the multiple processors, simply tie Pin 4 of the EZ-ICE header to ground.

If synchronous multiprocessor operations are needed and CLKIN is connected, clock skew between the multiple ADSP-21061/ADSP-21061L processors and the CLKIN pin on the EZ-ICE header *must be minimal*. If the skew is too large, synchronous operations may be off by one or more cycles between processors. For synchronous multiprocessor operation TCK,

TMS, CLKIN and $\overline{\text{EMU}}$ should be treated as critical signals in terms of skew, and should be laid out as short as possible on your board. If TCK, TMS and CLKIN are driving a large number of ADSP-21061 (more than eight) in your system, then treat them as a clock tree using multiple drivers to minimize skew. (See Figure 7, JTAG Clock Tree, and Clock Distribution in the High Frequency Design Considerations section of the *ADSP-2106x User's Manual, Second Edition*.)

If synchronous multiprocessor operations are not needed (i.e., CLKIN is not connected), just use appropriate parallel termination on TCK and TMS. TDI, TDO, $\overline{\text{EMU}}$ and $\overline{\text{TRST}}$ are not critical signals in terms of skew.

For complete information on the SHARC EZ-ICE, see the *ADSP-2100 Family JTAG EZ-ICE User's Guide and Reference*.

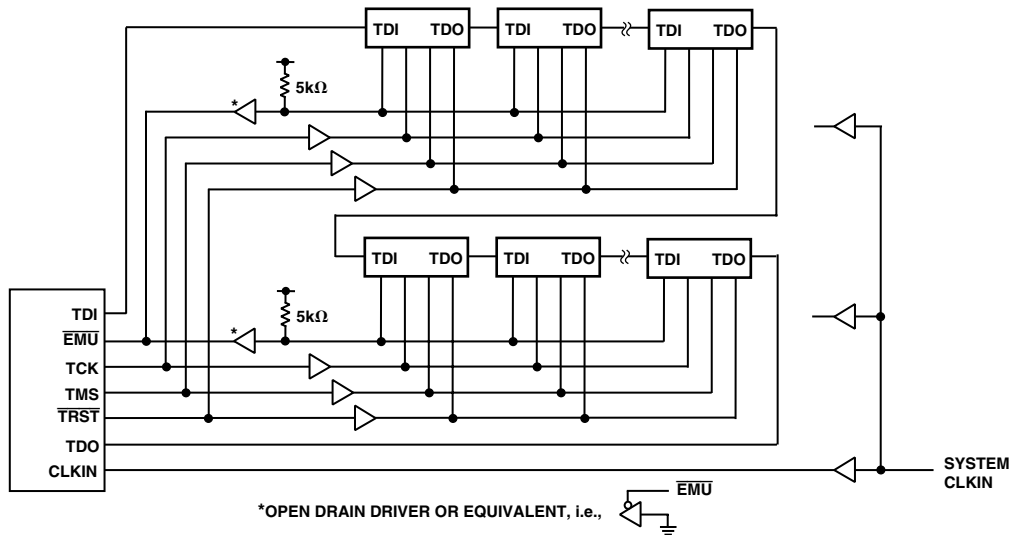

Figure 7. JTAG Clocktree for Multiple ADSP-2106x Systems

ADSP-21060—SPECIFICATIONS

RECOMMENDED OPERATING CONDITIONS (5 V)

| Parameter | Test Conditions | K Grade | | Units |
|-------------------|-----------------------------------------|-------------------------|-----------------------|-------|
| | | Min | Max | |
| V _{DD} | Supply Voltage | 4.75 | 5.25 | V |
| T _{CASE} | Case Operating Temperature | 0 | +85 | °C |
| V _{IH1} | High Level Input Voltage ¹ | @ V _{DD} = max | V _{DD} + 0.5 | V |
| V _{IH2} | High Level Input Voltage ² | @ V _{DD} = max | V _{DD} + 0.5 | V |
| V _{IL} | Low Level Input Voltage ^{1, 2} | @ V _{DD} = min | 0.8 | V |

NOTES

¹Applies to input and bidirectional pins: DATA₄₇₋₀, ADDR₃₁₋₀, \overline{RD} , \overline{WR} , \overline{SW} , \overline{ACK} , \overline{SBTS} , \overline{IRQ}_{2-0} , FLAG₃₋₀, \overline{HBG} , \overline{CS} , $\overline{DMAR1}$, $\overline{DMAR2}$, \overline{BR}_{6-1} , ID₂₋₀, RPBA, CPA, TFS0, TFS1, RFS0, RFS1, LxDAT₃₋₀, LxCLK, LxACK, EBOOT, LBOOT, \overline{BMS} , TMS, TDI, TCK, \overline{HBR} , DR0, DR1, TCLK0, TCLK1, RCLK0, RCLK1.

²Applies to input pins: CLKIN, \overline{RESET} , \overline{TRST} .

ELECTRICAL CHARACTERISTICS (5 V)

| Parameter | Test Conditions | Min | Max | Units |
|--------------------|---------------------------------------------------|----------------------------------------------------------------------------|-----|-------|
| V _{OH} | High Level Output Voltage ¹ | @ V _{DD} = min, I _{OH} = -2.0 mA ² | 4.1 | V |
| V _{OL} | Low Level Output Voltage ¹ | @ V _{DD} = min, I _{OL} = 4.0 mA ² | 0.4 | V |
| I _{IH} | High Level Input Current ^{3, 4} | @ V _{DD} = max, V _{IN} = V _{DD} max | 10 | μA |
| I _{IL} | Low Level Input Current ³ | @ V _{DD} = max, V _{IN} = 0 V | 10 | μA |
| I _{ILP} | Low Level Input Current ⁴ | @ V _{DD} = max, V _{IN} = 0 V | 150 | μA |
| I _{OZH} | Three-State Leakage Current ^{5, 6, 7, 8} | @ V _{DD} = max, V _{IN} = V _{DD} max | 10 | μA |
| I _{OZL} | Three-State Leakage Current ^{5, 9} | @ V _{DD} = max, V _{IN} = 0 V | 10 | μA |
| I _{OZHP} | Three-State Leakage Current ⁹ | @ V _{DD} = max, V _{IN} = V _{DD} max | 350 | μA |
| I _{OZLC} | Three-State Leakage Current ⁷ | @ V _{DD} = max, V _{IN} = 0 V | 1.5 | mA |
| I _{OZLA} | Three-State Leakage Current ¹⁰ | @ V _{DD} = max, V _{IN} = 1.5 V | 350 | μA |
| I _{OZLAR} | Three-State Leakage Current ⁸ | @ V _{DD} = max, V _{IN} = 0 V | 4.2 | mA |
| I _{OZLS} | Three-State Leakage Current ⁶ | @ V _{DD} = max, V _{IN} = 0 V | 150 | μA |
| C _{IN} | Input Capacitance ^{11, 12} | f _{IN} = 1 MHz, T _{CASE} = 25°C, V _{IN} = 2.5 V | 4.7 | pF |

NOTES

¹Applies to output and bidirectional pins: DATA₄₇₋₀, ADDR₃₁₋₀, \overline{MS}_{3-0} , \overline{RD} , \overline{WR} , PAGE, ADRCLK, \overline{SW} , ACK, FLAG₃₋₀, TIMEXP, \overline{HBG} , REDY, $\overline{DMAG1}$, $\overline{DMAG2}$, \overline{BR}_{6-1} , CPA, DT0, DT1, TCLK0, TCLK1, RCLK0, RCLK1, TFS0, TFS1, RFS0, RFS1, LxDAT₃₋₀, LxCLK, LxACK, \overline{BMS} , TDO, \overline{EMU} , ICSA.

²See "Output Drive Currents" for typical drive current capabilities.

³Applies to input pins: \overline{SBTS} , \overline{IRQ}_{2-0} , \overline{HBR} , \overline{CS} , $\overline{DMAR1}$, $\overline{DMAR2}$, ID₂₋₀, RPBA, EBOOT, LBOOT, CLKIN, \overline{RESET} , TCK.

⁴Applies to input pins with internal pull-ups: DR0, DR1, \overline{TRST} , TMS, TDI.

⁵Applies to three-statable pins: DATA₄₇₋₀, ADDR₃₁₋₀, \overline{MS}_{3-0} , \overline{RD} , \overline{WR} , PAGE, ADRCLK, \overline{SW} , ACK, FLAG₃₋₀, REDY, \overline{HBG} , $\overline{DMAG1}$, $\overline{DMAG2}$, \overline{BMS} , \overline{BR}_{6-1} , TFS_x, RFS_x, TDO, \overline{EMU} . (Note that ACK is pulled up internally with 2 kΩ during reset in a multiprocessor system, when ID₂₋₀ = 001 and another ADSP-21060 is not requesting bus mastership.)

⁶Applies to three-statable pins with internal pull-ups: DT0, DT1, TCLK0, TCLK1, RCLK0, RCLK1.

⁷Applies to CPA pin.

⁸Applies to ACK pin when pulled up. (Note that ACK is pulled up internally with 2 kΩ during reset in a multiprocessor system, when ID₂₋₀ = 001 and another ADSP-21060 is not requesting bus mastership.)

⁹Applies to three-statable pins with internal pull-downs: LxDAT₃₋₀, LxCLK, LxACK.

¹⁰Applies to ACK pin when keeper latch enabled.

¹¹Applies to all signal pins.

¹²Guaranteed but not tested.

Specifications subject to change without notice.

ADSP-21060/ADSP-21060L

POWER DISSIPATION ADSP-21060 (5 V)

These specifications apply to the internal power portion of V_{DD} only. See the Power Dissipation section of this data sheet for calculation of external supply current and total supply current. For a complete discussion of the code used to measure power dissipation, see the technical note “SHARC Power Dissipation Measurements.”

Specifications are based on the following operating scenarios:

| Operation | Peak Activity ($I_{DDINPEAK}$) | High Activity ($I_{DDINHIGH}$) | Low Activity ($I_{DDINLOW}$) |
|---------------------|----------------------------------|----------------------------------|--------------------------------|
| Instruction Type | Multifunction | Multifunction | Single Function |
| Instruction Fetch | Cache | Internal Memory | Internal Memory |
| Core Memory Access | 2 per Cycle (DM and PM) | 1 per Cycle (DM) | None |
| Internal Memory DMA | 1 per Cycle | 1 per 2 Cycles | 1 per 2 Cycles |

To estimate power consumption for a specific application, use the following equation where % is the amount of time your program spends in that state:

$$\%PEAK \times I_{DDINPEAK} + \%HIGH \times I_{DDINHIGH} + \%LOW \times I_{DDINLOW} + \%IDLE \times I_{DDIDLE} = \text{power consumption}$$

| Parameter | Test Conditions | Max | Units |
|-------------------------------------------------------|-----------------------------------------------|-----|-------|
| $I_{DDINPEAK}$ Supply Current (Internal) ¹ | $t_{CK} = 30 \text{ ns}, V_{DD} = \text{max}$ | 745 | mA |
| | $t_{CK} = 25 \text{ ns}, V_{DD} = \text{max}$ | 850 | mA |
| $I_{DDINHIGH}$ Supply Current (Internal) ² | $t_{CK} = 30 \text{ ns}, V_{DD} = \text{max}$ | 575 | mA |
| | $t_{CK} = 25 \text{ ns}, V_{DD} = \text{max}$ | 670 | mA |
| $I_{DDINLOW}$ Supply Current (Internal) ² | $t_{CK} = 30 \text{ ns}, V_{DD} = \text{max}$ | 340 | mA |
| | $t_{CK} = 25 \text{ ns}, V_{DD} = \text{max}$ | 390 | mA |
| I_{DDIDLE} Supply Current (Idle) ³ | $V_{DD} = \text{max}$ | 200 | mA |

NOTES

¹The test program used to measure $I_{DDINPEAK}$ represents worst case processor operation and is not sustainable under normal application conditions. Actual internal power measurements made using typical applications are less than specified.

² $I_{DDINHIGH}$ is a composite average based on a range of high activity code. $I_{DDINLOW}$ is a composite average based on a range of low activity code.

³Idle denotes ADSP-21060L state during execution of IDLE instruction.

ADSP-21060L—SPECIFICATIONS

RECOMMENDED OPERATING CONDITIONS (3.3 V)

| Parameter | Test Conditions | K Grade | | Units |
|-------------------|-----------------------------------------|-------------------------|-----------------------|-------|
| | | Min | Max | |
| V _{DD} | Supply Voltage | 3.15 | 3.45 | V |
| T _{CASE} | Case Operating Temperature | 0 | +85 | °C |
| V _{IH1} | High Level Input Voltage ¹ | @ V _{DD} = max | V _{DD} + 0.5 | V |
| V _{IH2} | High Level Input Voltage ² | @ V _{DD} = max | V _{DD} + 0.5 | V |
| V _{IL} | Low Level Input Voltage ^{1, 2} | @ V _{DD} = min | 0.8 | V |

NOTES

¹Applies to input and bidirectional pins: DATA₄₇₋₀, ADDR₃₁₋₀, \overline{RD} , \overline{WR} , \overline{SW} , \overline{ACK} , \overline{SBTS} , \overline{IRQ}_{2-0} , FLAG₃₋₀, \overline{HBG} , \overline{CS} , $\overline{DMAR1}$, $\overline{DMAR2}$, \overline{BR}_{6-1} , ID₂₋₀, RPBA, CPA, TFS0, TFS1, RFS0, RFS1, LxDAT₃₋₀, LxCLK, LxACK, EBOOT, LBOOT, BMS, TMS, TDI, TCK, HBR, DR0, DR1, TCLK0, TCLK1, RCLK0, RCLK1.

²Applies to input pins: CLKIN, \overline{RESET} , \overline{TRST} .

ELECTRICAL CHARACTERISTICS (3.3 V)

| Parameter | Test Conditions | Min | Max | Units |
|--------------------|---------------------------------------------------|----------------------------------------------------------------------------|-----|-------|
| V _{OH} | High Level Output Voltage ¹ | @ V _{DD} = min, I _{OH} = -2.0 mA ² | 2.4 | V |
| V _{OL} | Low Level Output Voltage ¹ | @ V _{DD} = min, I _{OL} = 4.0 mA ² | 0.4 | V |
| I _{IH} | High Level Input Current ^{3, 4} | @ V _{DD} = max, V _{IN} = V _{DD} max | 10 | μA |
| I _{IL} | Low Level Input Current ³ | @ V _{DD} = max, V _{IN} = 0 V | 10 | μA |
| I _{ILP} | Low Level Input Current ⁴ | @ V _{DD} = max, V _{IN} = 0 V | 150 | μA |
| I _{OZH} | Three-State Leakage Current ^{5, 6, 7, 8} | @ V _{DD} = max, V _{IN} = V _{DD} max | 10 | μA |
| I _{OZL} | Three-State Leakage Current ^{5, 9} | @ V _{DD} = max, V _{IN} = 0 V | 10 | μA |
| I _{OZHP} | Three-State Leakage Current ⁹ | @ V _{DD} = max, V _{IN} = V _{DD} max | 350 | μA |
| I _{OZLC} | Three-State Leakage Current ⁷ | @ V _{DD} = max, V _{IN} = 0 V | 1.5 | mA |
| I _{OZLA} | Three-State Leakage Current ¹⁰ | @ V _{DD} = max, V _{IN} = 1.5 V | 350 | μA |
| I _{OZLAR} | Three-State Leakage Current ⁸ | @ V _{DD} = max, V _{IN} = 0 V | 4.2 | mA |
| I _{OZLS} | Three-State Leakage Current ⁶ | @ V _{DD} = max, V _{IN} = 0 V | 150 | μA |
| C _{IN} | Input Capacitance ^{11, 12} | f _{IN} = 1 MHz, T _{CASE} = 25°C, V _{IN} = 2.5 V | 4.7 | pF |

NOTES

¹Applies to output and bidirectional pins: DATA₄₇₋₀, ADDR₃₁₋₀, \overline{MS}_{3-0} , \overline{RD} , \overline{WR} , PAGE, ADRCLK, \overline{SW} , \overline{ACK} , FLAG₃₋₀, TIMEEXP, \overline{HBG} , REDY, $\overline{DMAG1}$, $\overline{DMAG2}$, \overline{BR}_{6-1} , CPA, DT0, DT1, TCLK0, TCLK1, RCLK0, RCLK1, TFS0, TFS1, RFS0, RFS1, LxDAT₃₋₀, LxCLK, LxACK, BMS, TDO, \overline{EMU} , ICSA.

²See "Output Drive Currents" for typical drive current capabilities.

³Applies to input pins: \overline{SBTS} , \overline{IRQ}_{2-0} , HBR, \overline{CS} , $\overline{DMAR1}$, $\overline{DMAR2}$, ID₂₋₀, RPBA, EBOOT, LBOOT, CLKIN, \overline{RESET} , TCK.

⁴Applies to input pins with internal pull-ups: DR0, DR1, \overline{TRST} , TMS, TDI.

⁵Applies to three-statable pins: DATA₄₇₋₀, ADDR₃₁₋₀, \overline{MS}_{3-0} , \overline{RD} , \overline{WR} , PAGE, ADRCLK, \overline{SW} , \overline{ACK} , FLAG₃₋₀, REDY, \overline{HBG} , $\overline{DMAG1}$, $\overline{DMAG2}$, BMS, \overline{BR}_{6-1} , TFS_x, RFS_x, TDO, \overline{EMU} . (Note that ACK is pulled up internally with 2 kΩ during reset in a multiprocessor system, when ID₂₋₀ = 001 and another ADSP-21060 is not requesting bus mastership.)

⁶Applies to three-statable pins with internal pull-ups: DT0, DT1, TCLK0, TCLK1, RCLK0, RCLK1.

⁷Applies to CPA pin.

⁸Applies to ACK pin when pulled up. (Note that ACK is pulled up internally with 2 kΩ during reset in a multiprocessor system, when ID₂₋₀ = 001 and another ADSP-21060 is not requesting bus mastership).

⁹Applies to three-statable pins with internal pull-downs: LxDAT₃₋₀, LxCLK, LxACK.

¹⁰Applies to ACK pin when keeper latch enabled.

¹¹Applies to all signal pins.

¹²Guaranteed but not tested.

Specifications subject to change without notice.

ADSP-21060/ADSP-21060L

POWER DISSIPATION ADSP-21060L (3.3 V)

These specifications apply to the internal power portion of V_{DD} only. See the Power Dissipation section of this data sheet for calculation of external supply current and total supply current. For a complete discussion of the code used to measure power dissipation, see the technical note “SHARC Power Dissipation Measurements.”

Specifications are based on the following operating scenarios:

| Operation | Peak Activity ($I_{DDINPEAK}$) | High Activity ($I_{DDINHIGH}$) | Low Activity ($I_{DDINLOW}$) |
|---------------------|----------------------------------|----------------------------------|--------------------------------|
| Instruction Type | Multifunction | Multifunction | Single Function |
| Instruction Fetch | Cache | Internal Memory | Internal Memory |
| Core Memory Access | 2 per Cycle (DM and PM) | 1 per Cycle (DM) | None |
| Internal Memory DMA | 1 per Cycle | 1 per 2 Cycles | 1 per 2 Cycles |

To estimate power consumption for a specific application, use the following equation where % is the amount of time your program spends in that state:

$$\%PEAK \times I_{DDINPEAK} + \%HIGH \times I_{DDINHIGH} + \%LOW \times I_{DDINLOW} + \%IDLE \times I_{DDIDLE} = \text{power consumption}$$

| Parameter | Test Conditions | Max | Units |
|----------------|----------------------------------------|------------------------------------------------------------------------------------------------|------------------------|
| $I_{DDINPEAK}$ | Supply Current (Internal) ¹ | $t_{CK} = 30 \text{ ns}, V_{DD} = \text{max}$ $t_{CK} = 25 \text{ ns}, V_{DD} = \text{max}$ | 540 600 mA mA |
| $I_{DDINHIGH}$ | Supply Current (Internal) ² | $t_{CK} = 30 \text{ ns}, V_{DD} = \text{max}$ $t_{CK} = 25 \text{ ns}, V_{DD} = \text{max}$ | 425 475 mA mA |
| $I_{DDINLOW}$ | Supply Current (Internal) ² | $t_{CK} = 30 \text{ ns}, V_{DD} = \text{max}$ $t_{CK} = 25 \text{ ns}, V_{DD} = \text{max}$ | 250 275 mA mA |
| I_{DDIDLE} | Supply Current (Idle) ³ | $V_{DD} = \text{max}$ | 180 mA |

NOTES

¹The test program used to measure $I_{DDINPEAK}$ represents worst case processor operation and is not sustainable under normal application conditions. Actual internal power measurements made using typical applications are less than specified.

² $I_{DDINHIGH}$ is a composite average based on a range of high activity code. $I_{DDINLOW}$ is a composite average based on a range of low activity code.

³Idle denotes ADSP-21060L state during execution of IDLE instruction.

ADSP-21060/ADSP-21060L

ABSOLUTE MAXIMUM RATINGS (5 V)*

| | |
|---------------------------------|----------------------------|
| Supply Voltage | −0.3 V to +7 V |
| Input Voltage | −0.5 V to $V_{DD} + 0.5$ V |
| Output Voltage Swing | −0.5 V to $V_{DD} + 0.5$ V |
| Load Capacitance | 200 pF |
| Junction Temperature Under Bias | 130°C |
| Storage Temperature Range | −65°C to +150°C |
| Lead Temperature (5 seconds) | +280°C |

*Stresses greater than those listed above may cause permanent damage to the device. These are stress ratings only, and functional operation of the device at these or any other conditions greater than those indicated in the operational sections of this specification is not implied. Exposure to absolute maximum rating conditions for extended periods may affect device reliability.

ABSOLUTE MAXIMUM RATINGS (3.3 V)*

| | |
|---------------------------------|----------------------------|
| Supply Voltage | −0.3 V to +4.6 V |
| Input Voltage | −0.5 V to $V_{DD} + 0.5$ V |
| Output Voltage Swing | −0.5 V to $V_{DD} + 0.5$ V |
| Load Capacitance | 200 pF |
| Junction Temperature Under Bias | 130°C |
| Storage Temperature Range | −65°C to +150°C |
| Lead Temperature (5 seconds) | +280°C |

*Stresses greater than those listed above may cause permanent damage to the device. These are stress ratings only, and functional operation of the device at these or any other conditions greater than those indicated in the operational sections of this specification is not implied. Exposure to absolute maximum rating conditions for extended periods may affect device reliability.

ESD SENSITIVITY

ESD (electrostatic discharge) sensitive device. Electrostatic charges as high as 4000 V readily accumulate on the human body and test equipment and can discharge without detection. Although the ADSP-2106x features proprietary ESD protection circuitry, permanent damage may occur on devices subjected to high-energy electrostatic discharges. Therefore, proper ESD precautions are recommended to avoid performance degradation or loss of functionality.



TIMING SPECIFICATIONS

Two speed grades of the ADSP-21060 are offered, 40 MHz and 33.3 MHz. The specifications shown are based on a CLKIN frequency of 40 MHz ($t_{CK} = 25$ ns). The DT derating allows specifications at other CLKIN frequencies (within the min-max range of the t_{CK} specification; see Clock Input below). DT is the difference between the actual CLKIN period and a CLKIN period of 25 ns:

$$DT = t_{CK} - 25 \text{ ns}$$

Use the exact timing information given. Do not attempt to derive parameters from the addition or subtraction of others. While addition or subtraction would yield meaningful results for an individual device, the values given in this data sheet reflect statistical variations and worst cases. Consequently, you cannot meaningfully add parameters to derive longer times.

See Figure 28 under Test Conditions for voltage reference levels.

Switching Characteristics specify how the processor changes its signals. You have no control over this timing—circuitry external to the processor must be designed for compatibility with these signal characteristics. Switching characteristics tell you what the processor will do in a given circumstance. You can also use switching characteristics to ensure that any timing requirement of a device connected to the processor (such as memory) is satisfied.

Timing Requirements apply to signals that are controlled by circuitry external to the processor, such as the data input for a read operation. Timing requirements guarantee that the processor operates correctly with other devices.

(O/D) = Open Drain

(A/D) = Active Drive

ADSP-21060/ADSP-21060L

| Parameter | ADSP-21060 | | | | ADSP-21060L | | | | Units | | |
|-----------------------------|-------------------------------|-----|--------|-----|-------------|-----|--------|-----|-------|-----|----|
| | 40 MHz | | 33 MHz | | 40 MHz | | 33 MHz | | | | |
| | Min | Max | Min | Max | Min | Max | Min | Max | | | |
| Clock Input | | | | | | | | | | | |
| <i>Timing Requirements:</i> | | | | | | | | | | | |
| t_{CK} | CLKIN Period | | 25 | 100 | 30 | 100 | 25 | 100 | 30 | 100 | ns |
| t_{CKL} | CLKIN Width Low | | 7 | | 7 | | 8.75 | | 8.75 | | ns |
| t_{CKH} | CLKIN Width High | | 5 | | 5 | | 5 | | 5 | | ns |
| t_{CKRF} | CLKIN Rise/Fall (0.4 V–2.0 V) | | | 3 | | 3 | | 3 | | 3 | ns |

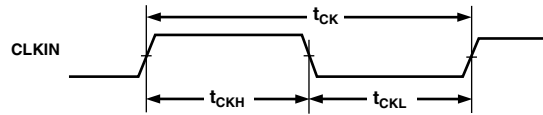

Figure 8. Clock Input

| Parameter | ADSP-21060 | | ADSP-21060L | | Units | | |
|-----------------------------|----------------------------------------------------------------|-----|-------------|----------|-------------|----------|----|
| | Min | Max | Min | Max | | | |
| Reset | | | | | | | |
| <i>Timing Requirements:</i> | | | | | | | |
| t_{WRST} | $\overline{\text{RESET}}$ Pulsewidth Low ¹ | | $4t_{CK}$ | | $4t_{CK}$ | ns | |
| t_{SRST} | $\overline{\text{RESET}}$ Setup before CLKIN High ² | | $14 + DT/2$ | t_{CK} | $14 + DT/2$ | t_{CK} | ns |

NOTES

¹Applies after the power-up sequence is complete. At power-up, the processor's internal phase-locked loop requires no more than 2000 CLKIN cycles while RESET is low, assuming stable V_{DD} and CLKIN (not including start-up time of external clock oscillator).

²Only required if multiple ADSP-2106xs must come out of reset synchronous to CLKIN with program counters (PC) equal (i.e., for a SIMD system). Not required for multiple ADSP-2106xs communicating over the shared bus (through the external port), because the bus arbitration logic synchronizes itself automatically after reset.

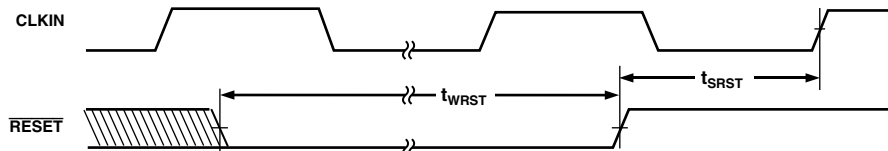

Figure 9. Reset

| Parameter | ADSP-21060 | | ADSP-21060L | | Units | |
|-----------------------------|-----------------------------------------------------------------|-----|--------------|--------------|--------------|----|
| | Min | Max | Min | Max | | |
| Interrupts | | | | | | |
| <i>Timing Requirements:</i> | | | | | | |
| t_{SIR} | $\overline{\text{IRQ2-0}}$ Setup before CLKIN High ¹ | | $18 + 3DT/4$ | | $18 + 3DT/4$ | ns |
| t_{HIR} | $\overline{\text{IRQ2-0}}$ Hold before CLKIN High ¹ | | | $12 + 3DT/4$ | $12 + 3DT/4$ | ns |
| t_{IPW} | $\overline{\text{IRQ2-0}}$ Pulsewidth ² | | $2 + t_{CK}$ | | $2 + t_{CK}$ | ns |

NOTES

¹Only required for $\overline{\text{IRQx}}$ recognition in the following cycle.

²Applies only if t_{SIR} and t_{HIR} requirements are not met.

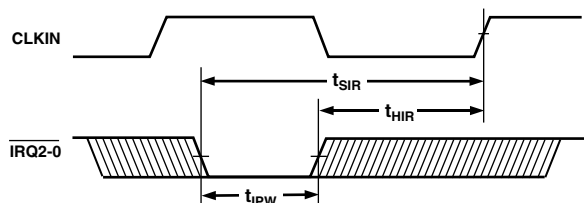

Figure 10. Interrupts

ADSP-21060/ADSP-21060L

| Parameter | ADSP-21060 | | ADSP-21060L | | Units |
|----------------------------------|------------|-----|-------------|-----|-------|
| | Min | Max | Min | Max | |
| Timer | | | | | |
| <i>Switching Characteristic:</i> | | | | | |
| t_{DTEX} | | 15 | | 15 | ns |

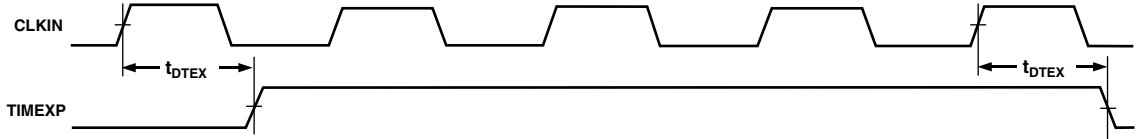

Figure 11. Timer

| Parameter | ADSP-21060 | | ADSP-21060L | | Units |
|-----------------------------------|----------------------------------------------------------------------------------------|-----|-------------|------------|-------|
| | Min | Max | Min | Max | |
| Flags | | | | | |
| <i>Timing Requirements:</i> | | | | | |
| t_{SFI} | FLAG3-0 _{IN} Setup before CLKIN High ¹ | | 8 + 5DT/16 | 8 + 5DT/16 | ns |
| t_{HFI} | FLAG3-0 _{IN} Hold after CLKIN High ¹ | | 0 - 5DT/16 | 0 - 5DT/16 | ns |
| t_{DWRFI} | FLAG3-0 _{IN} Delay after $\overline{RD}/\overline{WR}$ Low ¹ | | | 5 + 7DT/16 | ns |
| t_{HFIWR} | FLAG3-0 _{IN} Hold after $\overline{RD}/\overline{WR}$ Deasserted ¹ | | 0 | 5 + 7DT/16 | ns |
| <i>Switching Characteristics:</i> | | | | | |
| t_{DFO} | FLAG3-0 _{OUT} Delay after CLKIN High | | | 16 | ns |
| t_{HFO} | FLAG3-0 _{OUT} Hold after CLKIN High | | 4 | | ns |
| t_{DFOE} | CLKIN High to FLAG3-0 _{OUT} Enable | | 3 | | ns |
| t_{DFOD} | CLKIN High to FLAG3-0 _{OUT} Disable | | | 14 | ns |

NOTE

¹Flag inputs meeting these setup and hold times will affect conditional instructions in the following instruction cycle.

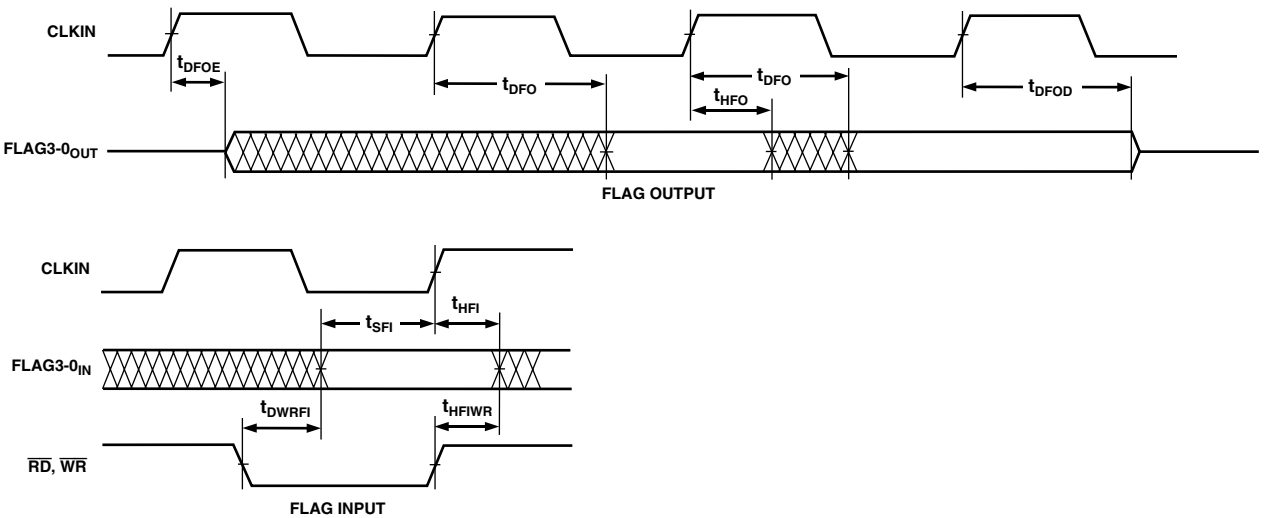

Figure 12. Flags

ADSP-21060/ADSP-21060L

Memory Read—Bus Master

Use these specifications for asynchronous interfacing to memories (and memory-mapped peripherals) without reference to CLKIN. These specifications apply when the ADSP-2106x is the bus master accessing external memory space. These switching

characteristics also apply for bus master synchronous read/write timing (see Synchronous Read/Write – Bus Master below). If these timing requirements are met, the synchronous read/write timing can be ignored (and vice versa).

| Parameter | ADSP-21060 | | ADSP-21060L | | Units |
|----------------------------------------------------------------------------------------------|--------------------|------------------|--------------------|------------------|-------|
| | Min | Max | Min | Max | |
| <i>Timing Requirements:</i> | | | | | |
| t_{DAD} Address, Selects Delay to Data Valid ^{1, 2} | | $18 + DT + W$ | | $18 + DT + W$ | ns |
| t_{DRLD} \overline{RD} Low to Data Valid ¹ | | $12 + 5DT/8 + W$ | | $12 + 5DT/8 + W$ | ns |
| t_{HDA} Data Hold from Address, Selects ³ | 0.5 | | 0.5 | | ns |
| t_{HDRH} Data Hold from \overline{RD} High ³ | 2.0 | | 2.0 | | ns |
| t_{DAAK} ACK Delay from Address, Selects ^{2, 4} | | $14 + 7DT/8 + W$ | | $14 + 7DT/8 + W$ | ns |
| t_{DSAK} ACK Delay from \overline{RD} Low ⁴ | | $8 + DT/2 + W$ | | $8 + DT/2 + W$ | ns |
| <i>Switching Characteristics:</i> | | | | | |
| t_{DRHA} Address, Selects Hold after \overline{RD} High | $0 + H$ | | $0 + H$ | | ns |
| t_{DARL} Address, Selects to \overline{RD} Low ² | $2 + 3DT/8$ | | $2 + 3DT/8$ | | ns |
| t_{RW} \overline{RD} Pulsewidth | $12.5 + 5DT/8 + W$ | | $12.5 + 5DT/8 + W$ | | ns |
| t_{RWR} \overline{RD} High to \overline{WR} , \overline{RD} , \overline{DMAGx} Low | $8 + 3DT/8 + HI$ | | $8 + 3DT/8 + HI$ | | ns |
| t_{SADADC} Address, Selects Setup before \overline{ADRCLK} High ² | $0 + DT/4$ | | $0 + DT/4$ | | ns |

W = (number of wait states specified in WAIT register) $\times t_{CK}$.

HI = t_{CK} (if an address hold cycle or bus idle cycle occurs, as specified in WAIT register; otherwise $HI = 0$).

H = t_{CK} (if an address hold cycle occurs as specified in WAIT register; otherwise $H = 0$).

NOTES

¹Data Delay/Setup: User must meet t_{DAD} or t_{DRLD} or synchronous spec t_{SSDATI} .

²The falling edge of \overline{MSx} , \overline{SW} , \overline{BMS} is referenced.

³Data Hold: User must meet t_{HDA} or t_{HDRH} or synchronous spec t_{HSDATI} . See *System Hold Time Calculation* under Test Conditions for the calculation of hold times given capacitive and dc loads.

⁴ACK Delay/Setup: User must meet t_{DAAK} or t_{DSAK} or synchronous specification t_{SACKG} for deassertion of ACK (Low), all three specifications must be met for assertion of ACK (High).

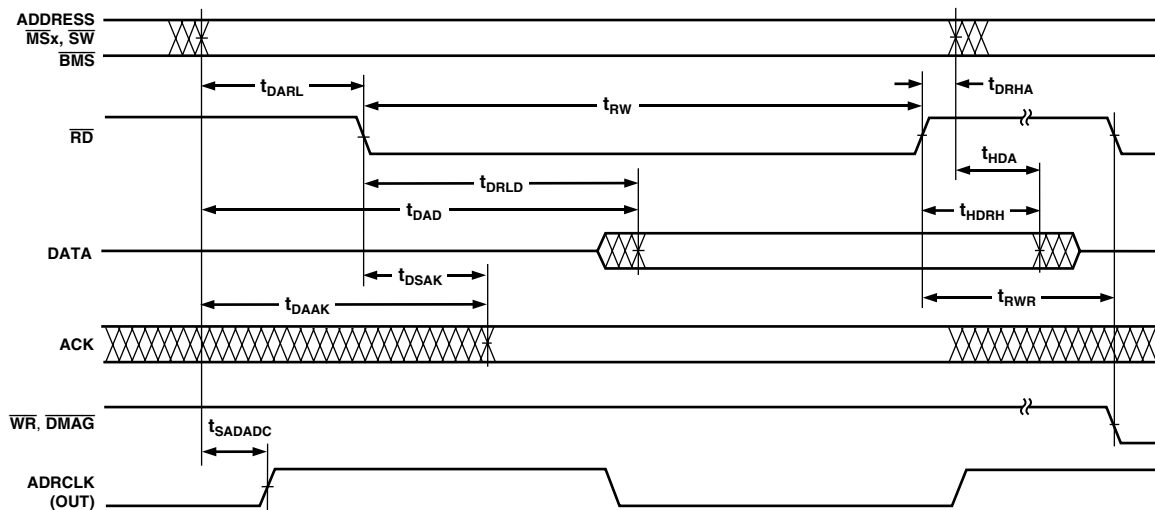

Figure 13. Memory Read—Bus Master

ADSP-21060/ADSP-21060L

Memory Write—Bus Master

Use these specifications for asynchronous interfacing to memories (and memory-mapped peripherals) without reference to CLKIN. These specifications apply when the ADSP-2106x is the bus master accessing external memory space. These switching

characteristics also apply for bus master synchronous read/write timing (see Synchronous Read/Write—Bus Master). If these timing requirements are met, the synchronous read/write timing can be ignored (and vice versa).

| Parameter | ADSP-21060 | | ADSP-21060L | | Units |
|---------------------------------------------------------------------------------------------------------------------------------|----------------------------------|--------------------------------|----------------------------------|--------------------------------|-------|
| | Min | Max | Min | Max | |
| <i>Timing Requirements:</i> | | | | | |
| t_{DAAK} ACK Delay from Address, Selects ^{1,2} | | $14 + 7\text{DT}/8 + \text{W}$ | | $14 + 7\text{DT}/8 + \text{W}$ | ns |
| t_{DSAK} ACK Delay from $\overline{\text{WR}}$ Low ¹ | | $8 + \text{DT}/2 + \text{W}$ | | $8 + \text{DT}/2 + \text{W}$ | ns |
| <i>Switching Characteristics:</i> | | | | | |
| t_{DAWH} Address, Selects to $\overline{\text{WR}}$ Deasserted ² | $17 + 15\text{DT}/16 + \text{W}$ | | $17 + 15\text{DT}/16 + \text{W}$ | | ns |
| t_{DAWL} Address, Selects to $\overline{\text{WR}}$ Low ² | $3 + 3\text{DT}/8$ | | $3 + 3\text{DT}/8$ | | ns |
| t_{WW} $\overline{\text{WR}}$ Pulsewidth | $12 + 9\text{DT}/16 + \text{W}$ | | $12 + 9\text{DT}/16 + \text{W}$ | | ns |
| t_{DDWH} Data Setup before $\overline{\text{WR}}$ High | $7 + \text{DT}/2 + \text{W}$ | | $7 + \text{DT}/2 + \text{W}$ | | ns |
| t_{DWHa} Address Hold after $\overline{\text{WR}}$ Deasserted | $0.5 + \text{DT}/16 + \text{H}$ | | $0.5 + \text{DT}/16 + \text{H}$ | | ns |
| t_{DATRWH} Data Disable after $\overline{\text{WR}}$ Deasserted ³ | $1 + \text{DT}/16 + \text{H}$ | $6 + \text{DT}/16 + \text{H}$ | $1 + \text{DT}/16 + \text{H}$ | $6 + \text{DT}/16 + \text{H}$ | ns |
| t_{WWR} $\overline{\text{WR}}$ High to $\overline{\text{WR}}$, $\overline{\text{RD}}$, $\overline{\text{DMAGx}}$ Low | $8 + 7\text{DT}/16 + \text{H}$ | | $8 + 7\text{DT}/16 + \text{H}$ | | ns |
| t_{DDWR} Data Disable before $\overline{\text{WR}}$ or $\overline{\text{RD}}$ Low | $5 + 3\text{DT}/8 + \text{I}$ | | $5 + 3\text{DT}/8 + \text{I}$ | | ns |
| t_{WDE} $\overline{\text{WR}}$ Low to Data Enabled | $-1 + \text{DT}/16$ | | $-1 + \text{DT}/16$ | | ns |
| t_{SADADC} Address, Selects to ADRCLK High ² | $0 + \text{DT}/4$ | | $0 + \text{DT}/4$ | | ns |

W = (number of wait states specified in WAIT register) × t_{CK} .

H = t_{CK} (if an address hold cycle occurs, as specified in WAIT register; otherwise H = 0).

I = t_{CK} (if a bus idle cycle occurs, as specified in WAIT register; otherwise I = 0).

NOTES

¹ACK Delay/Setup: User must meet t_{DAAK} or t_{DSAK} or synchronous specification t_{SACKC} for deassertion of ACK (Low), all three specifications must be met for assertion of ACK (High).

²The falling edge of $\overline{\text{MSx}}$, $\overline{\text{SW}}$, $\overline{\text{BMS}}$ is referenced.

³See *System Hold Time Calculation* under Test Conditions for calculation of hold times given capacitive and dc loads.

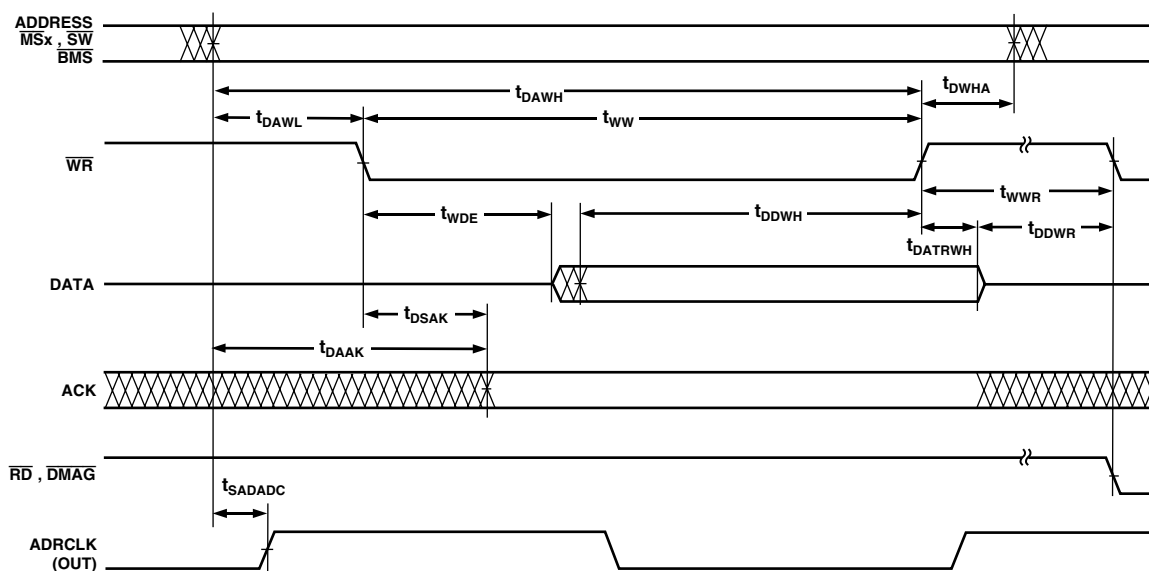

Figure 14. Memory Write—Bus Master

ADSP-21060/ADSP-21060L

Synchronous Read/Write—Bus Master

Use these specifications for interfacing to external memory systems that require CLKIN—relative timing or for accessing a slave ADSP-2106x (in multiprocessor memory space). These synchronous switching characteristics are also valid during asynchronous memory reads and writes (see Memory Read—Bus Master and Memory Write—Bus Master).

When accessing a slave ADSP-2106x, these switching characteristics must meet the slave's timing requirements for synchronous read/writes (see Synchronous Read/Write—Bus Slave). The slave ADSP-2106x must also meet these (bus master) timing requirements for data and acknowledge setup and hold times.

| Parameter | ADSP-21060 | | ADSP-21060L | | Units |
|------------------------------------------------------------------------------------------------------------------|--------------------------|-----------------|--------------------------|-----------------|-------|
| | Min | Max | Min | Max | |
| <i>Timing Requirements:</i> | | | | | |
| t _{SSDATI} Data Setup before CLKIN | 3 + DT/8 | | 3 + DT/8 | | ns |
| t _{HSDATI} Data Hold after CLKIN | 3.5 – DT/8 | | 3.5 – DT/8 | | ns |
| t _{DAAK} ACK Delay after Address, \overline{MSx} , \overline{SW} , \overline{BMS} ^{1, 2} | | 14 + 7 DT/8 + W | | 14 + 7 DT/8 + W | ns |
| t _{SACKC} ACK Setup before CLKIN ² | 6.5 + DT/4 | | 6.5 + DT/4 | | ns |
| t _{HACK} ACK Hold after CLKIN | –1 – DT/4 | | –1 – DT/4 | | ns |
| <i>Switching Characteristics:</i> | | | | | |
| t _{DADRO} Address, \overline{MSx} , \overline{BMS} , \overline{SW} Delay after CLKIN ¹ | | 7 – DT/8 | | 7 – DT/8 | ns |
| t _{HADRO} Address, \overline{MSx} , \overline{BMS} , \overline{SW} Hold after CLKIN | –1 – DT/8 | | –1 – DT/8 | | ns |
| t _{DPGC} PAGE Delay after CLKIN | 9 + DT/8 | 16 + DT/8 | 9 + DT/8 | 16 + DT/8 | ns |
| t _{DRDO} \overline{RD} High Delay after CLKIN | –2 – DT/8 | 4 – DT/8 | –2 – DT/8 | 4 – DT/8 | ns |
| t _{DWRO} \overline{WR} High Delay after CLKIN | –3 – 3DT/16 | 4 – 3DT/16 | –3 – 3DT/16 | 4 – 3DT/16 | ns |
| t _{DRWL} $\overline{RD}/\overline{WR}$ Low Delay after CLKIN | 8 + DT/4 | 12.5 + DT/4 | 8 + DT/4 | 12.5 + DT/4 | ns |
| t _{SDDATO} Data Delay after CLKIN | | 19 + 5DT/16 | | 19 + 5DT/16 | ns |
| t _{DATTR} Data Disable after CLKIN ³ | 0 – DT/8 | 7 – DT/8 | 0 – DT/8 | 7 – DT/8 | ns |
| t _{DADCKK} ADRCLK Delay after CLKIN | 4 + DT/8 | 10 + DT/8 | 4 + DT/8 | 10 + DT/8 | ns |
| t _{ADRCK} ADRCLK Period | | t _{CK} | | t _{CK} | ns |
| t _{ADRCKH} ADRCLK Width High | (t _{CK} /2) – 2 | | (t _{CK} /2) – 2 | | ns |
| t _{ADRCKL} ADRCLK Width Low | (t _{CK} /2) – 2 | | (t _{CK} /2) – 2 | | ns |

W = (number of Wait states specified in WAIT register) × t_{CK}.

NOTES

¹The falling edge of \overline{MSx} , \overline{SW} , \overline{BMS} is referenced.

²ACK Delay/Setup: User must meet t_{DAAK} or t_{DSAK} or synchronous specification t_{SACKC} for deassertion of ACK (Low), all three specifications must be met for assertion of ACK (High).

³See *System Hold Time Calculation* under Test Conditions for calculation of hold times given capacitive and dc loads.

ADSP-21060/ADSP-21060L

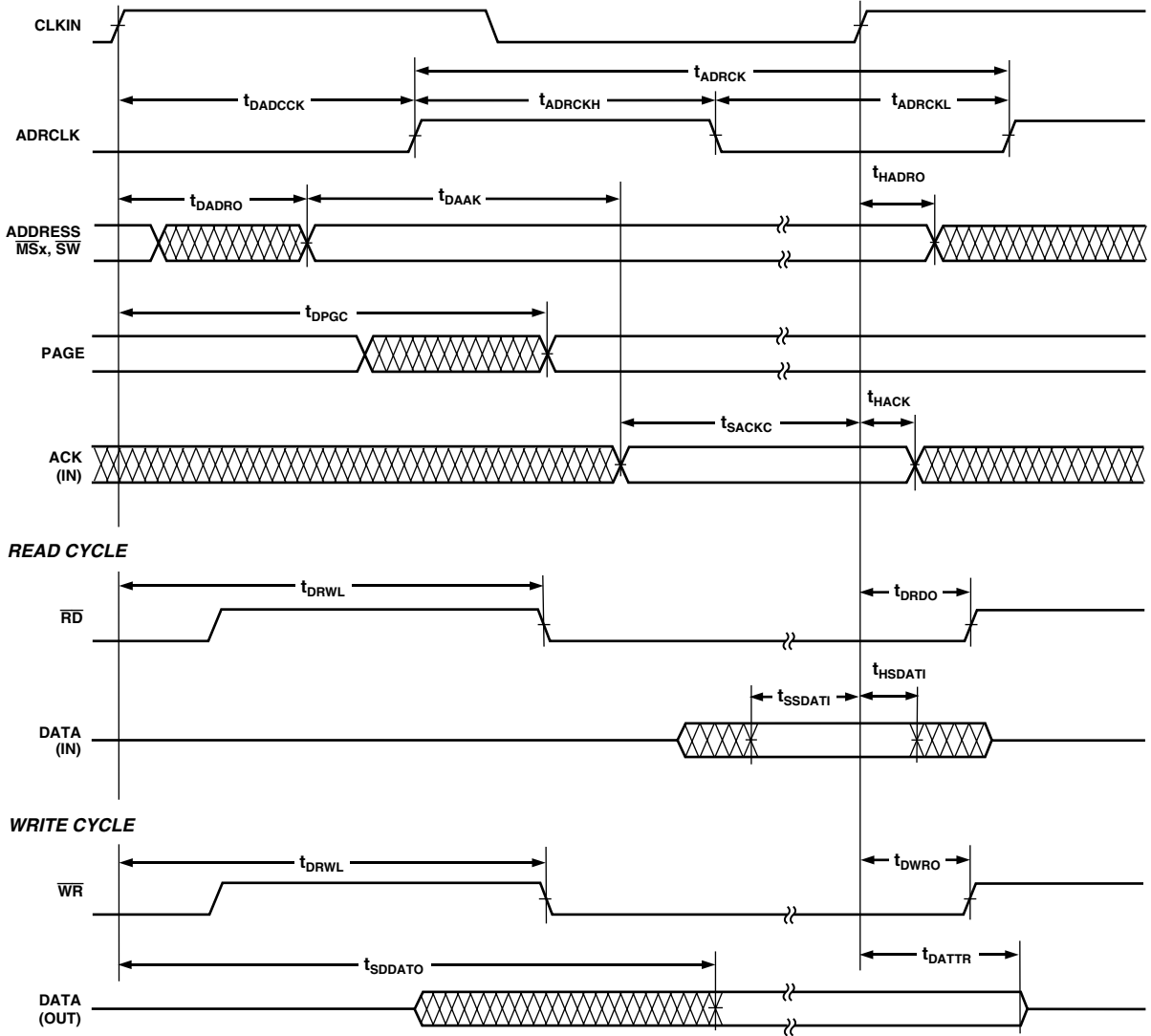

Figure 15. Synchronous Read/Write – Bus Master

ADSP-21060/ADSP-21060L

Synchronous Read/Write—Bus Slave

Use these specifications for ADSP-2106x bus master accesses of a slave's IOP registers or internal memory (in multiprocessor

memory space). The bus master must meet these (bus slave) timing requirements.

| Parameter | ADSP-21060 | | ADSP-21060L | | Units |
|-------------------------------------------------------------------------------|----------------|---------------|----------------|---------------|-------|
| | Min | Max | Min | Max | |
| <i>Timing Requirements:</i> | | | | | |
| t_{SADRI} Address, \overline{SW} Setup before CLKIN | $15 + DT/2$ | | $15 + DT/2$ | | ns |
| t_{HADRI} Address, \overline{SW} Hold before CLKIN | | $5 + DT/2$ | | $5 + DT/2$ | ns |
| t_{SRWLI} $\overline{RD}/\overline{WR}$ Low Setup before CLKIN ¹ | $9.5 + 5DT/16$ | | $9.5 + 5DT/16$ | | ns |
| t_{HRWLI} $\overline{RD}/\overline{WR}$ Low Hold after CLKIN | $-4 - 5DT/16$ | $8 + 7DT/16$ | $-4 - 5DT/16$ | $8 + 7DT/16$ | ns |
| t_{RWHPI} $\overline{RD}/\overline{WR}$ Pulse High | 3 | | 3 | | ns |
| t_{SDATWH} Data Setup before \overline{WR} High | 5 | | 5 | | ns |
| t_{HDATWH} Data Hold after \overline{WR} High | 1 | | 1 | | ns |
| <i>Switching Characteristics:</i> | | | | | |
| t_{SDDATO} Data Delay after CLKIN | | $19 + 5DT/16$ | | $19 + 5DT/16$ | ns |
| t_{DATTR} Data Disable after CLKIN ² | $0 - DT/8$ | $7 - DT/8$ | $0 - DT/8$ | $7 - DT/8$ | ns |
| t_{DACKAD} ACK Delay after Address, \overline{SW} ³ | | 9 | | 9 | ns |
| t_{ACKTR} ACK Disable after CLKIN ³ | $-1 - DT/8$ | $6 - DT/8$ | $-1 - DT/8$ | $6 - DT/8$ | ns |

NOTES

¹ t_{SRWLI} (min) = $9.5 + 5DT/16$ when Multiprocessor Memory Space Wait State (MMSWS bit in WAIT register) is disabled; when MMSWS is enabled, t_{SRWLI} (min) = $4 + DT/8$.

²See *System Hold Time Calculation* under Test Conditions for calculation of hold times given capacitive and dc loads.

³ t_{DACKAD} is true only if the address and \overline{SW} inputs have setup times (before CLKIN) greater than $10 + DT/8$ and less than $19 + 3DT/4$. If the address and \overline{SW} inputs have setup times greater than $19 + 3DT/4$, then ACK is valid $14 + DT/4$ (max) after CLKIN. A slave that sees an address with an M field match will respond with ACK regardless of the state of MMSWS or strobes. A slave will three-state ACK every cycle with t_{ACKTR} .

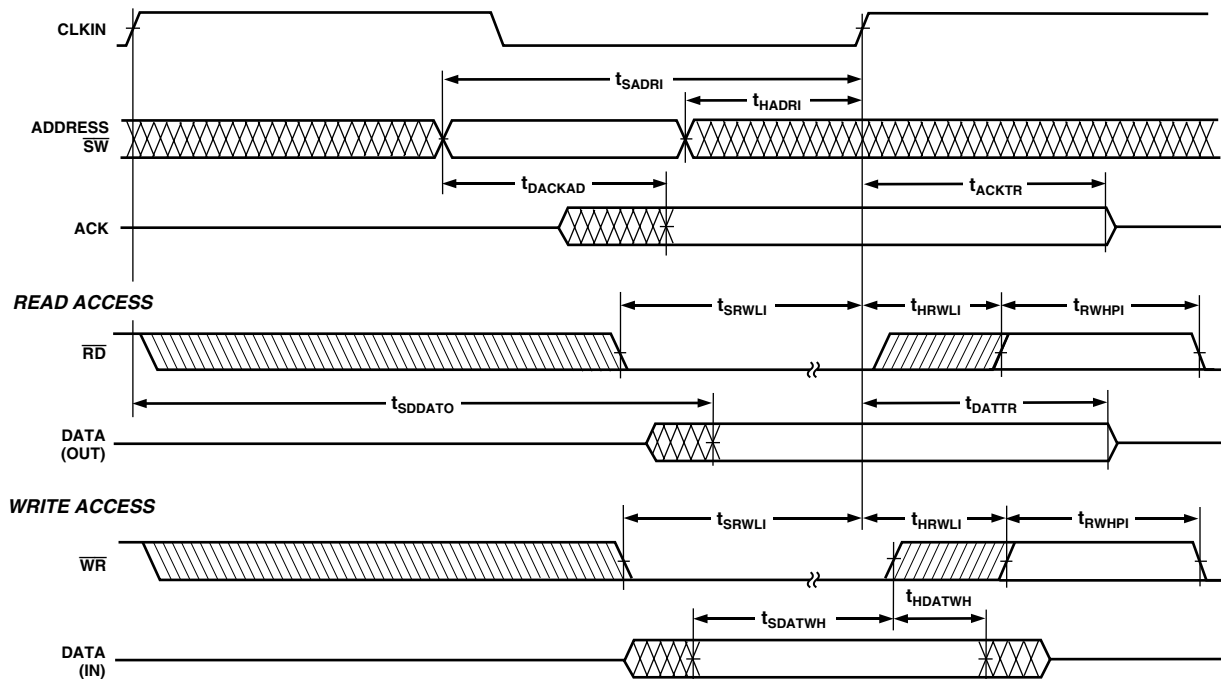

Figure 16. Synchronous Read/Write—Bus Slave

ADSP-21060/ADSP-21060L

Multiprocessor Bus Request and Host Bus Request

Use these specifications for passing of bus mastership between multiprocessing ADSP-2106xs ($\overline{\text{BRx}}$) or a host processor ($\overline{\text{HBR}}$, $\overline{\text{HBG}}$).

| Parameter | ADSP-21060 | | ADSP-21060L | | Units |
|-----------------------------------------------------------------------------------------------------------------------------------------|--------------|------------|--------------|------------|-------|
| | Min | Max | Min | Max | |
| <i>Timing Requirements:</i> | | | | | |
| t_{HBGRCSV} $\overline{\text{HBG}}$ Low to $\overline{\text{RD}}/\overline{\text{WR}}/\overline{\text{CS}}$ Valid ¹ | | 20+ 5DT/4 | | 20+ 5DT/4 | ns |
| t_{SHBRI} $\overline{\text{HBR}}$ Setup before CLKIN ² | 20 + 3DT/4 | | 20 + 3DT/4 | | ns |
| t_{HHBRI} $\overline{\text{HBR}}$ Hold before CLKIN ² | | 14 + 3DT/4 | | 14 + 3DT/4 | ns |
| t_{SHBGI} $\overline{\text{HBG}}$ Setup before CLKIN | 13 + DT/2 | | 13 + DT/2 | | ns |
| t_{HHBGI} $\overline{\text{HBG}}$ Hold before CLKIN High | | 6 + DT/2 | | 6 + DT/2 | ns |
| t_{SBRI} $\overline{\text{BRx}}$, $\overline{\text{CPA}}$ Setup before CLKIN ³ | 13 + DT/2 | | 13 + DT/2 | | ns |
| t_{HBRI} $\overline{\text{BRx}}$, $\overline{\text{CPA}}$ Hold before CLKIN High | | 6 + DT/2 | | 6 + DT/2 | ns |
| t_{SRPBAI} RPBA Setup before CLKIN | 21 + 3DT/4 | | 21 + 3DT/4 | | ns |
| t_{HRPBAI} RPBA Hold before CLKIN | | 12 + 3DT/4 | | 12 + 3DT/4 | ns |
| <i>Switching Characteristics:</i> | | | | | |
| t_{DHBGO} $\overline{\text{HBG}}$ Delay after CLKIN | | 7 – DT/8 | | 7 – DT/8 | ns |
| t_{HHBGO} $\overline{\text{HBG}}$ Hold after CLKIN | –2 – DT/8 | | –2 – DT/8 | | ns |
| t_{DBRO} $\overline{\text{BRx}}$ Delay after CLKIN | | 7 – DT/8 | | 7 – DT/8 | ns |
| t_{HBRO} $\overline{\text{BRx}}$ Hold after CLKIN | –2 – DT/8 | | –2 – DT/8 | | ns |
| t_{DCPAO} $\overline{\text{CPA}}$ Low Delay after CLKIN | | 8 – DT/8 | | 8 – DT/8 | ns |
| t_{TRCPA} $\overline{\text{CPA}}$ Disable after CLKIN | –2 – DT/8 | 4.5 – DT/8 | –2 – DT/8 | 4.5 – DT/8 | ns |
| t_{DRDYCS} REDY (O/D) or (A/D) Low from $\overline{\text{CS}}$ and $\overline{\text{HBR}}$ Low ⁴ | | 8.5 | | 9.25 | ns |
| t_{TRDYHG} REDY (O/D) Disable or REDY (A/D) High from $\overline{\text{HBG}}$ ⁴ | 44 + 23DT/16 | | 44 + 23DT/16 | | ns |
| t_{ARDYTR} REDY (A/D) Disable from $\overline{\text{CS}}$ or $\overline{\text{HBR}}$ High ⁴ | | 10 | | 10 | ns |

NOTES

¹For first asynchronous access after $\overline{\text{HBR}}$ and $\overline{\text{CS}}$ asserted, ADDR_{31-0} must be a non-MMS value $1/2 t_{\text{CK}}$ before $\overline{\text{RD}}$ or $\overline{\text{WR}}$ goes low or by t_{HBGRCSV} after $\overline{\text{HBG}}$ goes low. This is easily accomplished by driving an upper address signal high when $\overline{\text{HBG}}$ is asserted. See the “Host Processor Control of the ADSP-2106x” section in the *ADSP-2106x SHARC User’s Manual, Second Edition*.

²Only required for recognition in the current cycle.

³ $\overline{\text{CPA}}$ assertion must meet the setup to CLKIN; deassertion does not need to meet the setup to CLKIN.

⁴(O/D) = open drain, (A/D) = active drive.

ADSP-21060/ADSP-21060L

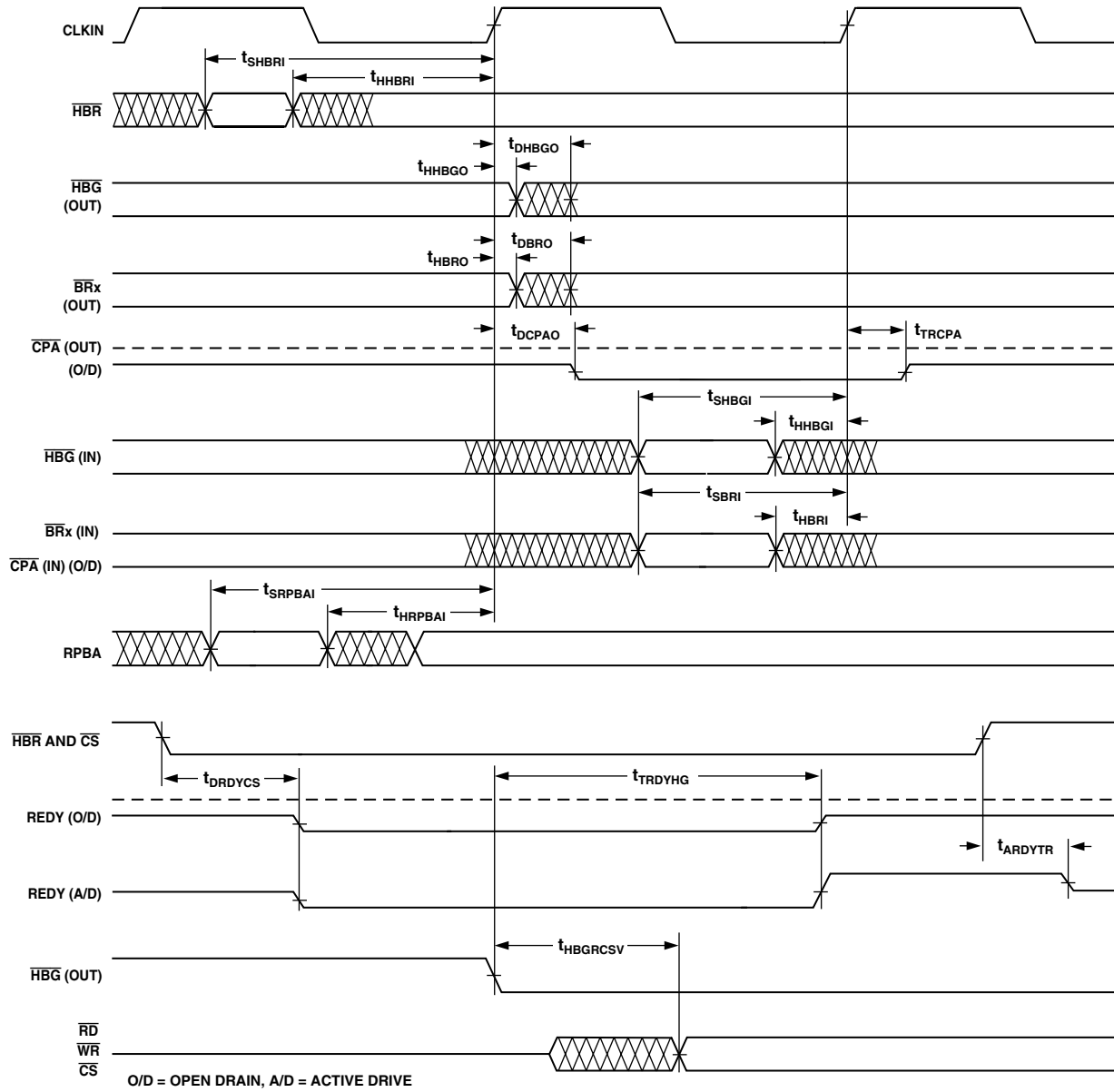

Figure 17. Multiprocessor Bus Request and Host Bus Request

ADSP-21060/ADSP-21060L

Asynchronous Read/Write—Host to ADSP-2106x

Use these specifications for asynchronous host processor accesses of an ADSP-2106x, after the host has asserted \overline{CS} and \overline{HBR} (low). After \overline{HBG} is returned by the ADSP-2106x, the host can

drive the \overline{RD} and \overline{WR} pins to access the ADSP-2106x's internal memory or IOP registers. \overline{HBR} and \overline{HBG} are assumed low for this timing.

| Parameter | ADSP-21060 | | ADSP-21060L | | Units |
|-----------------------------------|----------------------------------------------------------------------------|-----|----------------|--------------|-------|
| | Min | Max | Min | Max | |
| Read Cycle | | | | | |
| <i>Timing Requirements:</i> | | | | | |
| t_{SADRDL} | Address Setup/ \overline{CS} Low before \overline{RD} Low ¹ | | 0 | | ns |
| t_{HADRDH} | Address Hold/ \overline{CS} Hold Low after \overline{RD} | | 0 | | ns |
| t_{WRWH} | $\overline{RD}/\overline{WR}$ High Width | | 6 | | ns |
| $t_{DRDHRDY}$ | \overline{RD} High Delay after REDY (O/D) Disable | | 0 | | ns |
| $t_{DRDHRDY}$ | \overline{RD} High Delay after REDY (A/D) Disable | | 0 | | ns |
| <i>Switching Characteristics:</i> | | | | | |
| $t_{SDATRDY}$ | Data Valid before REDY Disable from Low | | 2 | | ns |
| $t_{DRDYRDL}$ | REDY (O/D) or (A/D) Low Delay after \overline{RD} Low | | | 10 | ns |
| t_{RDYPRD} | REDY (O/D) or (A/D) Low Pulsewidth for Read | | $45 + 21DT/16$ | | ns |
| t_{HDARWH} | Data Disable after \overline{RD} High | | 2 | 8 | ns |
| Write Cycle | | | | | |
| <i>Timing Requirements:</i> | | | | | |
| t_{SCSWRL} | \overline{CS} Low Setup before \overline{WR} Low | | 0 | | ns |
| t_{HCSWRH} | \overline{CS} Low Hold after \overline{WR} High | | 0 | | ns |
| t_{SADWRH} | Address Setup before \overline{WR} High | | 5 | | ns |
| t_{HADWRH} | Address Hold after \overline{WR} High | | 2 | | ns |
| t_{WWRL} | \overline{WR} Low Width | | 7 | | ns |
| t_{WRWH} | $\overline{RD}/\overline{WR}$ High Width | | 6 | | ns |
| $t_{DWRHRDY}$ | \overline{WR} High Delay after REDY (O/D) or (A/D) Disable | | 0 | | ns |
| t_{SDATWH} | Data Setup before \overline{WR} High | | 5 | | ns |
| t_{HDATWH} | Data Hold after \overline{WR} High | | 1 | | ns |
| <i>Switching Characteristics:</i> | | | | | |
| $t_{DRDYWRL}$ | REDY (O/D) or (A/D) Low Delay after $\overline{WR}/\overline{CS}$ Low | | | 10 | ns |
| t_{RDYPWR} | REDY (O/D) or (A/D) Low Pulsewidth for Write | | $15 + 7DT/16$ | | ns |
| t_{SRDYCK} | REDY (O/D) or (A/D) Disable to CLKIN | | $1 + 7DT/16$ | $8 + 7DT/16$ | ns |

NOTE

¹Not required if \overline{RD} and address are valid $t_{HBGRCSV}$ after \overline{HBG} goes low. For first access after \overline{HBR} asserted, $ADDR_{31:0}$ must be a non-MMS value $1/2 t_{CLK}$ before \overline{RD} or \overline{WR} goes low or by $t_{HBGRCSV}$ after \overline{HBG} goes low. This is easily accomplished by driving an upper address signal high when \overline{HBG} is asserted. See the "Host Processor Control of the ADSP-2106x" section in the *ADSP-2106x SHARC User's Manual, Second Edition*.

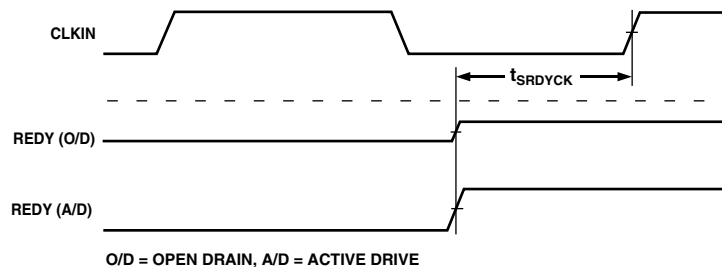

Figure 18a. Synchronous REDY Timing

ADSP-21060/ADSP-21060L

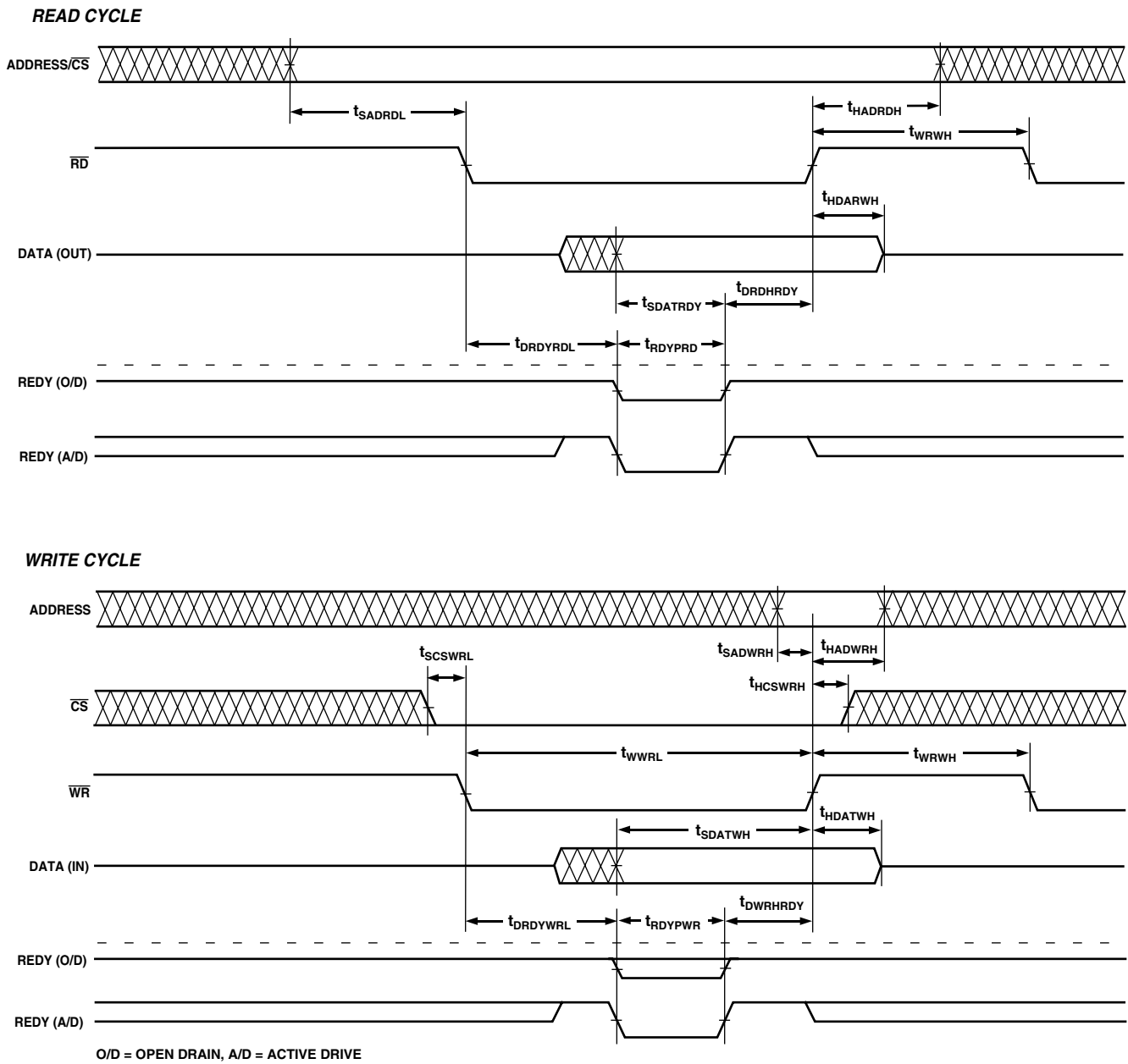

Figure 18b. Asynchronous Read/Write—Host to ADSP-2106x

ADSP-21060/ADSP-21060L

Three-State Timing—Bus Master, Bus Slave, $\overline{\text{HBR}}$, $\overline{\text{SBTS}}$
 These specifications show how the memory interface is disabled (stops driving) or enabled (resumes driving) relative to CLKIN

and the $\overline{\text{SBTS}}$ pin. This timing is applicable to bus master transition cycles (BTC) and host transition cycles (HTC) as well as the $\overline{\text{SBTS}}$ pin.

| Parameter | ADSP-21060 | | ADSP-21060L | | Units |
|----------------------------------------------------------------------------------------------|-------------|------------|--------------|------------|-------|
| | Min | Max | Min | Max | |
| <i>Timing Requirements:</i> | | | | | |
| t_{STSCk} $\overline{\text{SBTS}}$ Setup before CLKIN | 12 + DT/2 | | 12 + DT/2 | | ns |
| t_{HTSCk} $\overline{\text{SBTS}}$ Hold before CLKIN | | 6 + DT/2 | | 6 + DT/2 | ns |
| <i>Switching Characteristics:</i> | | | | | |
| t_{MIENA} Address/Select Enable after CLKIN | -1.5 - DT/8 | | -1.25 - DT/8 | | ns |
| t_{MIENS} Strobes Enable after CLKIN ¹ | -1.5 - DT/8 | | -1.5 - DT/8 | | ns |
| t_{MIENHG} $\overline{\text{HBG}}$ Enable after CLKIN | -1.5 - DT/8 | | -1.5 - DT/8 | | ns |
| t_{MITRA} Address/Select Disable after CLKIN | | 0 - DT/4 | | 0 - DT/4 | ns |
| t_{MITRS} Strobes Disable after CLKIN ¹ | | 1.5 - DT/4 | | 1.5 - DT/4 | ns |
| t_{MITRHG} $\overline{\text{HBG}}$ Disable after CLKIN | | 2.0 - DT/4 | | 2.0 - DT/4 | ns |
| t_{DATEN} Data Enable after CLKIN ² | 9 + 5DT/16 | | 9 + 5DT/16 | | ns |
| t_{DATTR} Data Disable after CLKIN ² | 0 - DT/8 | 7 - DT/8 | 0 - DT/8 | 7 - DT/8 | ns |
| t_{ACKEN} ACK Enable after CLKIN ² | 7.5 + DT/4 | | 7.5 + DT/4 | | ns |
| t_{ACKTR} ACK Disable after CLKIN ² | -1 - DT/8 | 6 - DT/8 | -1 - DT/8 | 6 - DT/8 | ns |
| t_{ADCEN} ADRCLK Enable after CLKIN | -2 - DT/8 | | -2 - DT/8 | | ns |
| t_{ADCTR} ADRCLK Disable after CLKIN | | 8 - DT/4 | | 8 - DT/4 | ns |
| t_{MTRHBG} Memory Interface Disable before $\overline{\text{HBG}}$ Low ³ | 0 + DT/8 | | 0 + DT/8 | | ns |
| t_{MENHBG} Memory Interface Enable after $\overline{\text{HBG}}$ High ³ | 19 + DT | | 19 + DT | | ns |

NOTES
¹Strobes = $\overline{\text{RD}}$, $\overline{\text{WR}}$, $\overline{\text{SW}}$, PAGE, $\overline{\text{DMAG}}$.
²In addition to bus master transition cycles, these specs also apply to bus master and bus slave synchronous read/write.
³Memory Interface = Address, $\overline{\text{RD}}$, $\overline{\text{WR}}$, $\overline{\text{MSx}}$, $\overline{\text{SW}}$, $\overline{\text{HBG}}$, PAGE, $\overline{\text{DMAGx}}$, $\overline{\text{BMS}}$ (in EPROM boot mode).

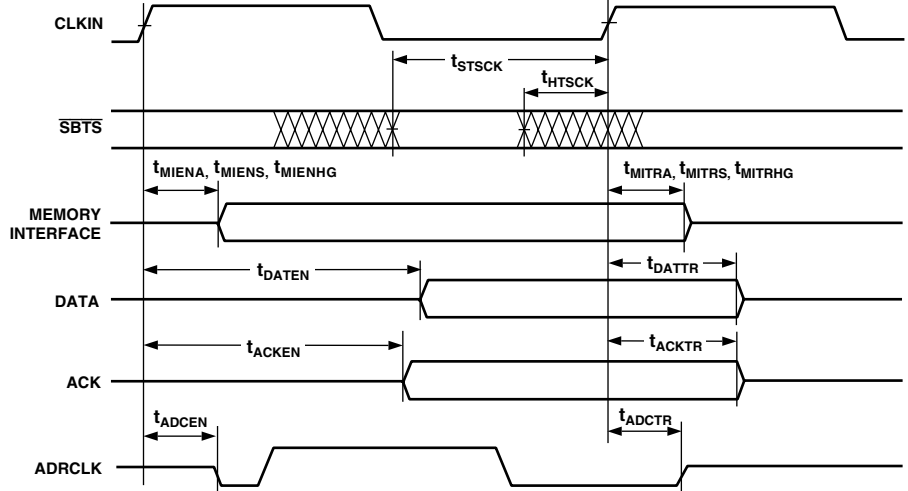

Figure 19a. Three-State Timing (Bus Transition Cycle, $\overline{\text{SBTS}}$ Assertion)

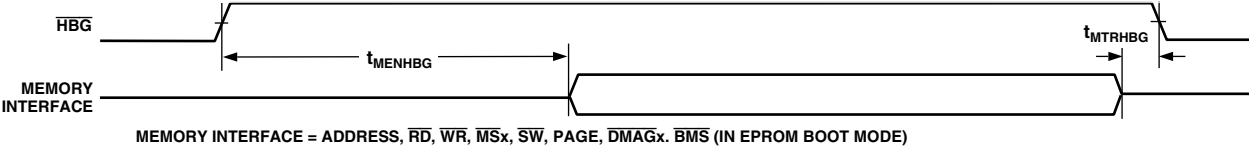

Figure 19b. Three-State Timing (Host Transition Cycle)

ADSP-21060/ADSP-21060L

DMA Handshake

These specifications describe the three DMA handshake modes. In all three modes DMAR is used to initiate transfers. For handshake mode, DMAG controls the latching or enabling of data externally. For external handshake mode, the data transfer is controlled by the ADDR₃₁₋₀, RD, WR, SW, PAGE, MS₃₋₀, ACK, and DMAG signals. For Paced Master mode, the data

transfer is controlled by ADDR₃₁₋₀, RD, WR, MS₃₋₀, and ACK (not DMAG). For Paced Master mode, the Memory Read-Bus Master, Memory Write-Bus Master, and Synchronous Read/Write-Bus Master timing specifications for ADDR₃₁₋₀, RD, WR, MS₃₋₀, SW, PAGE, DATA₄₇₋₀, and ACK also apply.

| Parameter | ADSP-21060 | | ADSP-21060L | | Units |
|-----------------------------------|-----------------|------------|-----------------|------------|-------|
| | Min | Max | Min | Max | |
| <i>Timing Requirements:</i> | | | | | |
| t _{SDRLC} | 5 | | 5 | | ns |
| t _{SDRHC} | 5 | | 5 | | ns |
| t _{WDR} | 6 | | 6 | | ns |
| t _{SDATDGL} | | 10 + 5DT/8 | | 10 + 5DT/8 | ns |
| t _{HDATIDG} | 2 | | 2 | | ns |
| t _{DATDRH} | | 16 + 7DT/8 | | 16 + 7DT/8 | ns |
| t _{DMARLL} | 23 + 7DT/8 | | 23 + 7DT/8 | | ns |
| t _{DMARH} | 6 | | 6 | | ns |
| <i>Switching Characteristics:</i> | | | | | |
| t _{DDGL} | 9 + DT/4 | 15 + DT/4 | 9 + DT/4 | 15 + DT/4 | ns |
| t _{WDGH} | 6 + 3DT/8 | | 6 + 3DT/8 | | ns |
| t _{WDGL} | 12 + 5DT/8 | | 12 + 5DT/8 | | ns |
| t _{HDGC} | -2 - DT/8 | 6 - DT/8 | -2 - DT/8 | 6 - DT/8 | ns |
| t _{VDATDGH} | 8 + 9DT/16 | | 8 + 9DT/16 | | ns |
| t _{DATDRGH} | 0 | 7 | 0 | 7 | ns |
| t _{DGWRL} | 0 | 2 | 0 | 2 | ns |
| t _{DGWRH} | 10 + 5DT/8 + W | | 10 + 5DT/8 + W | | ns |
| t _{DGWRR} | 1 + DT/16 | 3 + DT/16 | 1 + DT/16 | 3 + DT/16 | ns |
| t _{DGRDL} | 0 | 2 | 0 | 2 | ns |
| t _{DRDGH} | 11 + 9DT/16 + W | | 11 + 9DT/16 + W | | ns |
| t _{DGRDR} | 0 | 3 | 0 | 3 | ns |
| t _{DGWR} | 5 + 3DT/8 + HI | | 5 + 3DT/8 + HI | | ns |
| t _{DADGH} | 17 + DT | | 17 + DT | | ns |
| t _{DDGHA} | -0.5 | | -0.5 | | ns |

W = (number of wait states specified in WAIT register) × t_{CK}.

HI = t_{CK} (if an address hold cycle or bus idle cycle occurs, as specified in WAIT register; otherwise HI = 0).

NOTES

¹Only required for recognition in the current cycle.

²t_{SDATDGL} is the data setup requirement if DMARx is not being used to hold off completion of a write. Otherwise, if DMARx low holds off completion of the write, the data can be driven t_{DATDRH} after DMARx is brought high.

³t_{VDATDGH} is valid if DMARx is not being used to hold off completion of a read. If DMARx is used to prolong the read, then t_{VDATDGH} = 8 + 9DT/16 + (n × t_{CK}) where n equals the number of extra cycles that the access is prolonged.

⁴See *System Hold Time Calculation* under Test Conditions for calculation of hold times given capacitive and dc loads.

ADSP-21060/ADSP-21060L

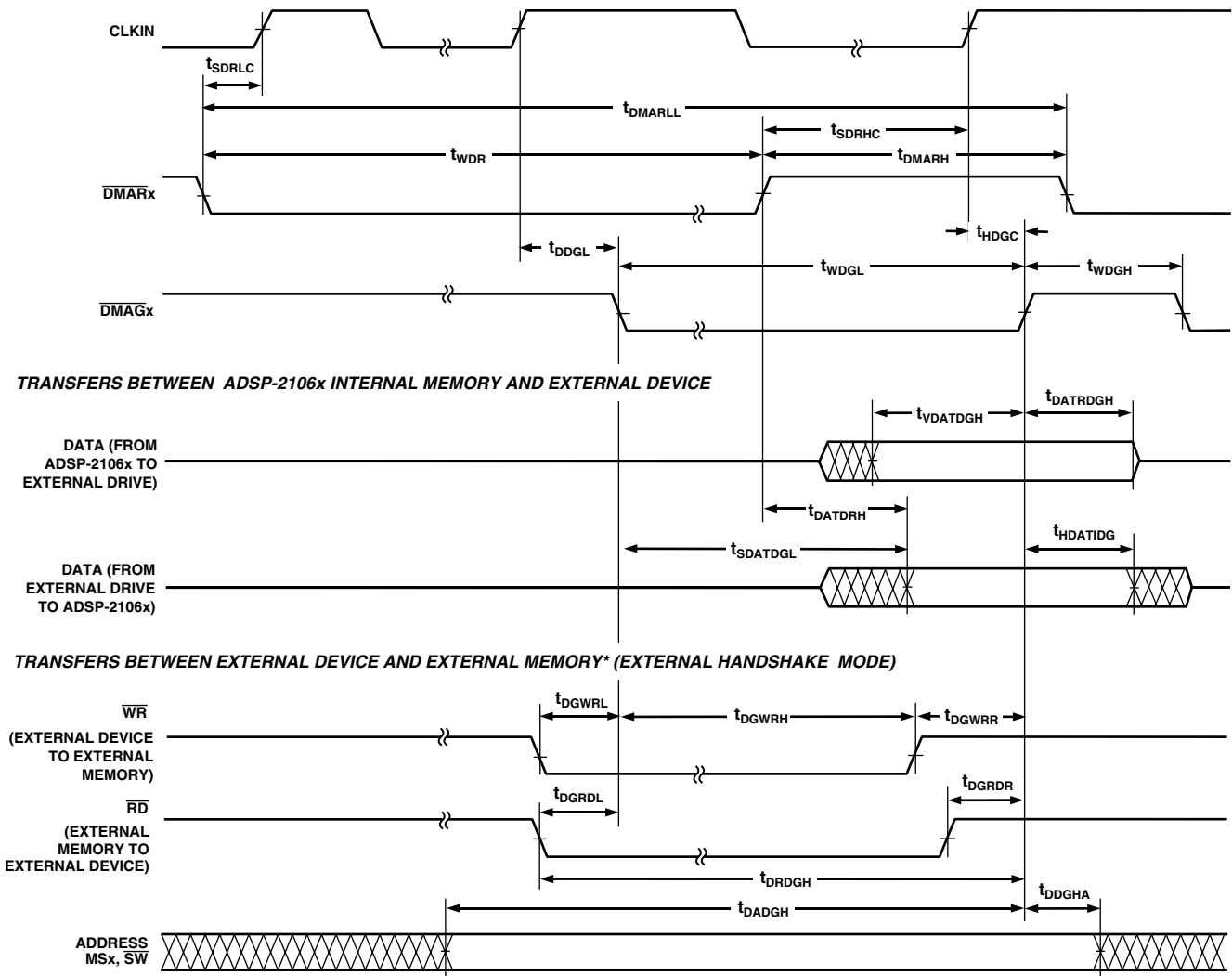

* MEMORY READ – BUS MASTER, MEMORY WRITE – BUS MASTER, AND SYNCHRONOUS READ/WRITE – BUS MASTER TIMING SPECIFICATIONS FOR ADDR₃₁₋₀, RD, WR, SW, MS₃₋₀ AND ACK ALSO APPLY HERE.

Figure 20. DMA Handshake Timing

ADSP-21060/ADSP-21060L

Link Ports: 1 × CLK Speed Operation

| Parameter | ADSP-21060 | | ADSP-21060L | | Units |
|---------------------------------------------------------------------------|----------------------------|-------------------------------|-----------------------------|---------------------------------|-------|
| | Min | Max | Min | Max | |
| Receive | | | | | |
| <i>Timing Requirements:</i> | | | | | |
| t _{SLDCL} Data Setup before LCLK Low | 3.5 | | 3 | | ns |
| t _{HLDCL} Data Hold after LCLK Low | 3 | | 3 | | ns |
| t _{LCLKIW} LCLK Period (1 × Operation) | t _{CK} | | t _{CK} | | ns |
| t _{LCLKRWL} LCLK Width Low | 6 | | 6 | | ns |
| t _{LCLKRWH} LCLK Width High | 5 | | 5 | | ns |
| <i>Switching Characteristics:</i> | | | | | |
| t _{DLAHC} LACK High Delay after CLKIN High | 18 + DT/2 | 28.5 + DT/2 | 18 + DT/2 | 28.5 + DT/2 | ns |
| t _{DLALC} LACK Low Delay after LCLK High ¹ | -3 | 13 | -3 | 13 | ns |
| t _{ENDLK} LACK Enable from CLKIN | 5 + DT/2 | | 5 + DT/2 | | ns |
| t _{TDLK} LACK Disable from CLKIN | | 20 + DT/2 | | 20 + DT/2 | ns |
| Transmit | | | | | |
| <i>Timing Requirements:</i> | | | | | |
| t _{SLACH} LACK Setup before LCLK High | 18 | | 20 | | ns |
| t _{HLACH} LACK Hold after LCLK High | -7 | | -7 | | ns |
| <i>Switching Characteristics:</i> | | | | | |
| t _{DLCCLK} LCLK Delay after CLKIN (1 × operation) | | 15.5 | | 16.5 | ns |
| t _{DLDCH} Data Delay after LCLK High | | 3 | | 2.5 | ns |
| t _{HLDCH} Data Hold after LCLK High | -3 | | -3 | | ns |
| t _{LCLKTWL} LCLK Width Low | (t _{CK} /2) - 2 | (t _{CK} /2) + 2 | (t _{CK} /2) - 1 | (t _{CK} /2) + 1.25 | ns |
| t _{LCLKTWH} LCLK Width High | (t _{CK} /2) - 2 | (t _{CK} /2) + 2 | (t _{CK} /2) - 1.25 | (t _{CK} /2) + 1.0 | ns |
| t _{DLACK} LCLK Low Delay after LACK High | (t _{CK} /2) + 8.5 | (3 × t _{CK} /2) + 17 | (t _{CK} /2) + 8.0 | (3 × t _{CK} /2) + 17.5 | ns |
| t _{ENDLK} LDAT, LCLK Enable after CLKIN | 5 + DT/2 | | 5 + DT/2 | | ns |
| t _{TDLK} LDAT, LCLK Disable after CLKIN | | 20 + DT/2 | | 20 + DT/2 | ns |
| Link Port Service Request Interrupts: 1 × and 2 × Speed Operations | | | | | |
| <i>Timing Requirements:</i> | | | | | |
| t _{SLCK} LACK/LCLK Setup before CLKIN Low ² | 10 | | 10 | | ns |
| t _{HLCK} LACK/LCLK Hold after CLKIN Low ² | 2 | | 2 | | ns |

NOTES

¹LACK will go low with t_{DLALC} relative to rising edge of LCLK after first nibble is received. LACK will not go low if the receiver's link buffer is not about to fill.

²Only required for interrupt recognition in the current cycle.

ADSP-21060/ADSP-21060L

Link Ports: 2 × CLK Speed Operation

Calculation of link receiver data setup and hold relative to link clock is required to determine the maximum allowable skew that can be introduced in the transmission path between LDATA and LCLK. Setup skew is the maximum delay that can be introduced in LDATA relative to LCLK, (setup skew = $t_{LCLKTWH \text{ min}} - t_{DLDC} - t_{SLDCL}$). Hold skew is the maximum delay that can be introduced in LCLK relative to LDATA, (hold skew = $t_{LCLKTWL \text{ min}} - t_{HLDCH} - t_{HLDCL}$). Calculations made directly from 2 × speed specifications will result in unrealistically small skew times because they include multiple tester guardbands. The setup and hold skew times shown below are calculated to include only one tester guardband.

ADSP-21060 Setup Skew = 1.93 ns max

ADSP-21060 Hold Skew = 2.95 ns max

ADSP-21060L Setup Skew = 1.87 ns max

ADSP-21060L Hold Skew = 1.69 ns max

| Parameter | ADSP-21060 | | ADSP-21060L | | Units |
|---------------------------------------------------------|------------------|-------------------------|---------------------|-------------------------|-------|
| | Min | Max | Min | Max | |
| Receive | | | | | |
| <i>Timing Requirements:</i> | | | | | |
| t_{SLDCL} Data Setup before LCLK Low | 2.5 | | 2.25 | | ns |
| t_{HLDCL} Data Hold after LCLK Low | 2.25 | | 2.25 | | ns |
| t_{LCLKIW} LCLK Period (2 × Operation) | $t_{CK}/2$ | | $t_{CK}/2$ | | ns |
| $t_{LCLKRWL}$ LCLK Width Low | 4.5 | | 5.0 | | ns |
| $t_{LCLKRWH}$ LCLK Width High | 4.25 | | 4.0 | | ns |
| <i>Switching Characteristics:</i> | | | | | |
| t_{DLAHC} LACK High Delay after CLKIN High | 18 + DT/2 | 28.5 + DT/2 | 18 + DT/2 | 29.5 + DT/2 | ns |
| t_{DLALC} LACK Low Delay after LCLK High ¹ | 6 | 16 | 6 | 18 | ns |
| Transmit | | | | | |
| <i>Timing Requirements:</i> | | | | | |
| t_{SLACH} LACK Setup before LCLK High | 19 | | 19 | | ns |
| t_{HLACH} LACK Hold after LCLK High | -6.75 | | -6.5 | | ns |
| <i>Switching Characteristics:</i> | | | | | |
| t_{DLCLK} LCLK Delay after CLKIN | | 8 | | 8 | ns |
| t_{DLDC} Data Delay after LCLK High | | 2.5 | | 2.25 | ns |
| t_{HLDCH} Data Hold after LCLK High | -2.0 | | -2.0 | | ns |
| $t_{LCLKTWL}$ LCLK Width Low | $(t_{CK}/4) - 1$ | $(t_{CK}/4) + 1$ | $(t_{CK}/4) - 0.75$ | $(t_{CK}/4) + 1.5$ | ns |
| $t_{LCLKTWH}$ LCLK Width High | $(t_{CK}/4) - 1$ | $(t_{CK}/4) + 1$ | $(t_{CK}/4) - 1.5$ | $(t_{CK}/4) + 1$ | ns |
| t_{DLACLK} LCLK Low Delay after LACK High | $(t_{CK}/4) + 9$ | $(3 * t_{CK}/4) + 16.5$ | $(t_{CK}/4) + 9$ | $(3 * t_{CK}/4) + 16.5$ | ns |

NOTE

¹LACK will go low with t_{DLALC} relative to rising edge of LCLK after first nibble is received. LACK will not go low if the receiver's link buffer is not about to fill.

ADSP-21060/ADSP-21060L

TRANSMIT

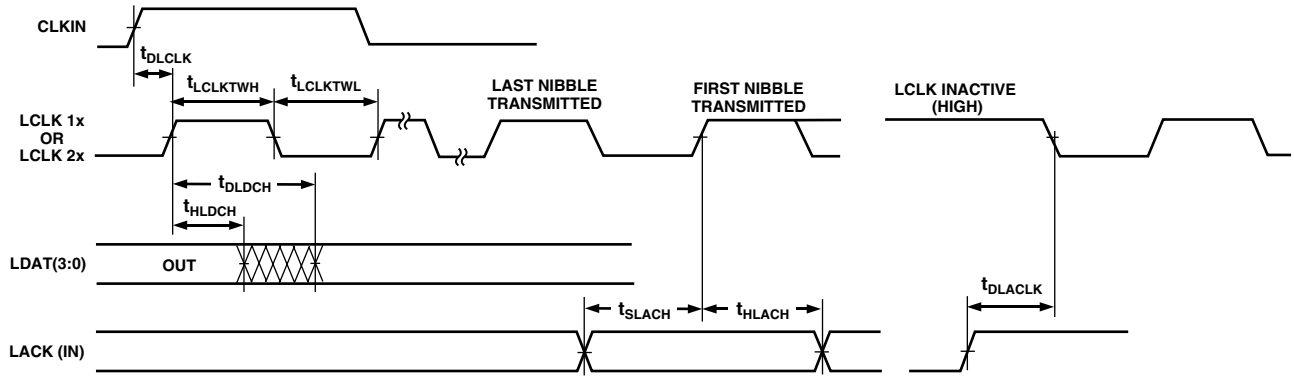

THE t_{SLACH} REQUIREMENT APPLIES TO THE RISING EDGE OF LCLK ONLY FOR THE FIRST NIBBLE TRANSMITTED.

RECEIVE

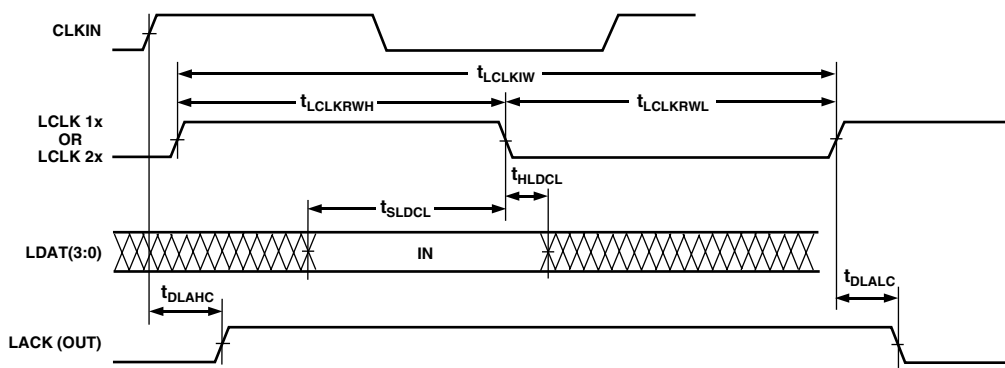

LINK PORT ENABLE/THREE-STATE DELAY FROM INSTRUCTION

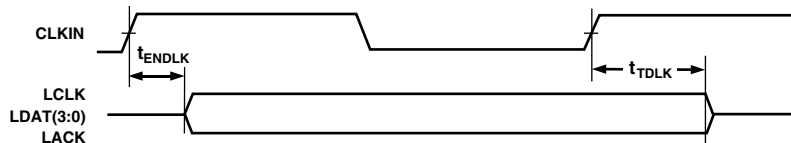

LINK PORT ENABLE OR THREE-STATE TAKES EFFECT 2 CYCLES AFTER A WRITE TO A LINK PORT CONTROL REGISTER.

LINK PORT INTERRUPT SETUP TIME

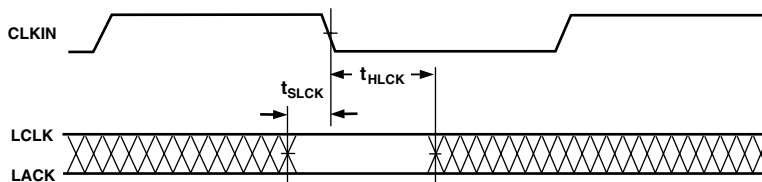

Figure 21. Link Ports

ADSP-21060/ADSP-21060L

Serial Ports

| Parameter | ADSP-21060 | | ADSP-21060L | | Units |
|------------------------------------------------------------------------|--------------------------------------------------------------------------------------|-----|----------------------------|----------------------------|-------|
| | Min | Max | Min | Max | |
| External Clock | | | | | |
| <i>Timing Requirements:</i> | | | | | |
| t _{SFSE} | TFS/RFS Setup before TCLK/RCLK ¹ | | 3.5 | | ns |
| t _{HFSE} | TFS/RFS Hold after TCLK/RCLK ^{1,2} | | 4 | | ns |
| t _{SDRE} | Receive Data Setup before RCLK ¹ | | 1.5 | | ns |
| t _{HDRE} | Receive Data Hold after RCLK ¹ | | 4 | | ns |
| t _{SCLKW} | TCLK/RCLK Width | | 9.5 | | ns |
| t _{SCLK} | TCLK/RCLK Period | | t _{CK} | | ns |
| Internal Clock | | | | | |
| <i>Timing Requirements:</i> | | | | | |
| t _{SFSI} | TFS Setup before TCLK ¹ ; RFS Setup before RCLK ¹ | | 8 | | ns |
| t _{HFSI} | TFS/RFS Hold after TCLK/RCLK ^{1,2} | | 1 | | ns |
| t _{SDRI} | Receive Data Setup before RCLK ¹ | | 3 | | ns |
| t _{HDRI} | Receive Data Hold after RCLK ¹ | | 3 | | ns |
| External or Internal Clock | | | | | |
| <i>Switching Characteristics:</i> | | | | | |
| t _{DFSE} | RFS Delay after RCLK (Internally Generated RFS) ³ | | | 13 | ns |
| t _{HOFSE} | RFS Hold after RCLK (Internally Generated RFS) ³ | | 3 | | ns |
| External Clock | | | | | |
| <i>Switching Characteristics:</i> | | | | | |
| t _{DFSE} | TFS Delay after TCLK (Internally Generated TFS) ³ | | | 13 | ns |
| t _{HOFSE} | TFS Hold after TCLK (Internally Generated TFS) ³ | | 3 | | ns |
| t _{DDTE} | Transmit Data Delay after TCLK ³ | | | 16 | ns |
| t _{HODTE} | Transmit Data Hold after TCLK ³ | | 5 | | ns |
| Internal Clock | | | | | |
| <i>Switching Characteristics:</i> | | | | | |
| t _{DFSI} | TFS Delay after TCLK (Internally Generated TFS) ³ | | | 4.5 | ns |
| t _{HOFSI} | TFS Hold after TCLK (Internally Generated TFS) ³ | | -1.5 | | ns |
| t _{DDTI} | Transmit Data Delay after TCLK ³ | | | 7.5 | ns |
| t _{HDTI} | Transmit Data Hold after TCLK ³ | | 0 | | ns |
| t _{SCLKIW} | TCLK/RCLK Width | | (t _{SCLK} /2) - 2 | (t _{SCLK} /2) + 2 | ns |
| Enable and Three-State | | | | | |
| <i>Switching Characteristics:</i> | | | | | |
| t _{DDTEN} | Data Enable from External TCLK ³ | | 3.5 | | ns |
| t _{DDTTE} | Data Disable from External TCLK ³ | | | 10.5 | ns |
| t _{DDTIN} | Data Enable from Internal TCLK ³ | | 0 | | ns |
| t _{DDTTI} | Data Disable from Internal TCLK ³ | | | 3 | ns |
| t _{DCLK} | TCLK/RCLK Delay from CLKIN | | | 22 + 3DT/8 | ns |
| t _{DPTR} | SPORT Disable after CLKIN | | | 17 | ns |
| Gated SCLK with External TFS (Mesh Multiprocessing)⁴ | | | | | |
| <i>Timing Requirements:</i> | | | | | |
| t _{STFSCK} | TFS Setup before CLKIN | | 5 | | ns |
| t _{HTFSCK} | TFS Hold after CLKIN | | t _{CK} /2 | | ns |
| External Late Frame Sync | | | | | |
| <i>Switching Characteristics:</i> | | | | | |
| t _{DDTLFSE} | Data Delay from Late External TFS or External RFS with MCE = 1, MFD = 0 ⁵ | | | 12 | ns |
| t _{DDTENFS} | Data Enable from late FS or MCE = 1, MFD = 0 ⁵ | | 3 | | ns |

To determine whether communication is possible between two devices at clock speed *n*, the following specifications must be confirmed: 1) frame sync delay & frame sync setup and hold, 2) data delay & data setup and hold, and 3) SCLK width.

ADSP-21060/ADSP-21060L

NOTES

- ¹Referenced to sample edge.
- ²RFS hold after RCK when MCE = 1, MFD = 0 is 0 ns minimum from drive edge. TFS hold after TCK for late external TFS is 0 ns minimum from drive edge.
- ³Referenced to drive edge.
- ⁴Applies only to gated serial clock mode used for serial port system I/O in mesh multiprocessing systems.
- ⁵MCE = 1, TFS enable and TFS valid follow $t_{DDTLFSE}$ and $t_{DDTENFS}$.

DATA RECEIVE- INTERNAL CLOCK

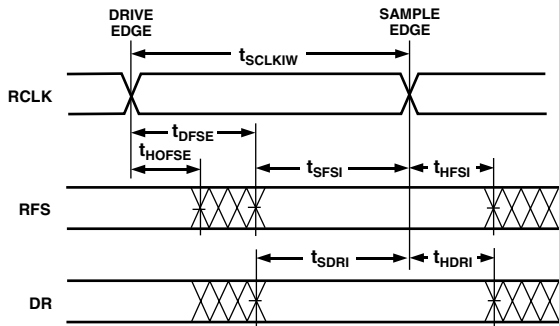

NOTE: EITHER THE RISING EDGE OR FALLING EDGE OF RCLK, TCLK CAN BE USED AS THE ACTIVE SAMPLING EDGE.

DATA RECEIVE- EXTERNAL CLOCK

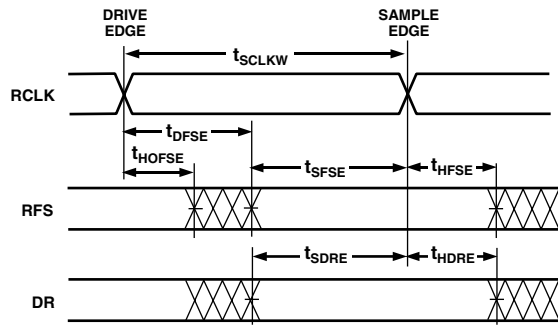

DATA TRANSMIT- INTERNAL CLOCK

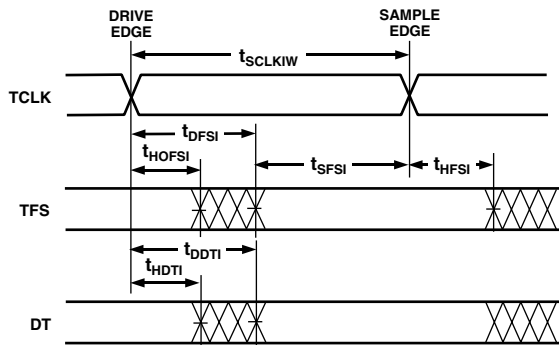

NOTE: EITHER THE RISING EDGE OR FALLING EDGE OF RCLK, TCLK CAN BE USED AS THE ACTIVE SAMPLING EDGE.

DATA TRANSMIT- EXTERNAL CLOCK

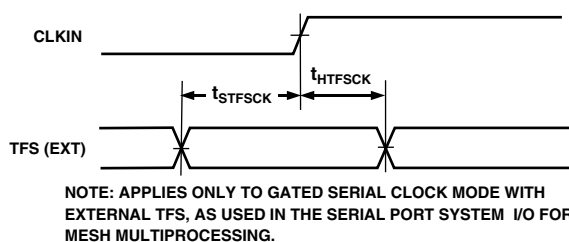
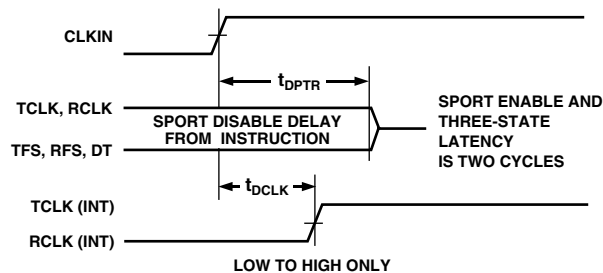
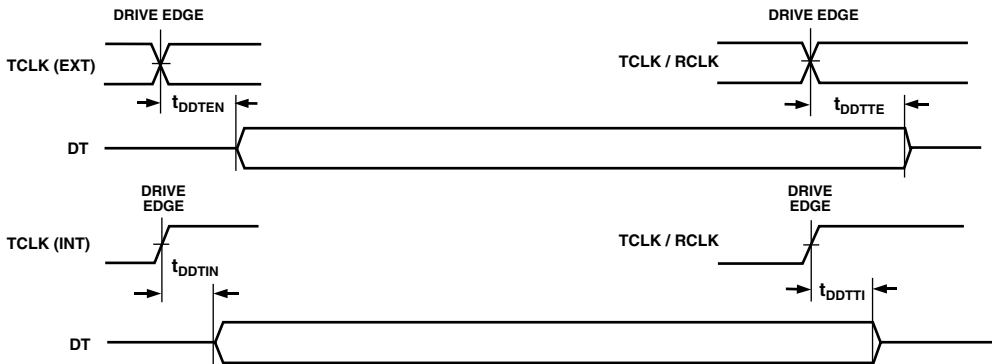
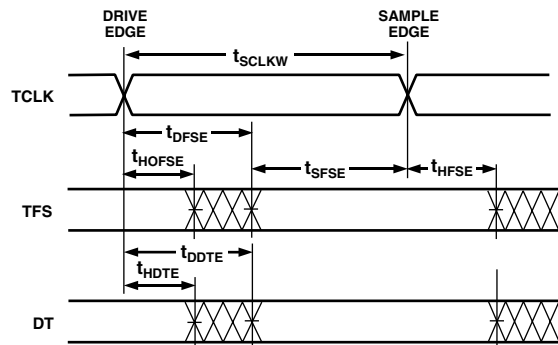

NOTE: APPLIES ONLY TO GATED SERIAL CLOCK MODE WITH EXTERNAL TFS, AS USED IN THE SERIAL PORT SYSTEM I/O FOR MESH MULTIPROCESSING.

Figure 22. Serial Ports

EXTERNAL RFS with MCE = 1, MFD = 0

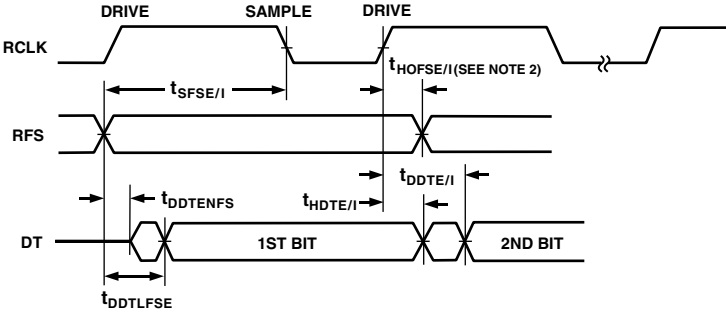

LATE EXTERNAL TFS

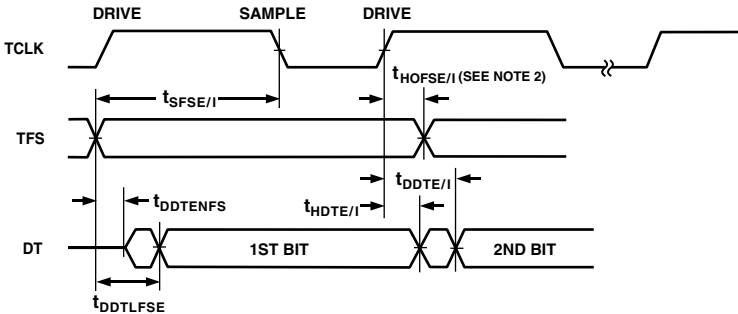

Figure 23. External Late Frame Sync

ADSP-21060/ADSP-21060L

JTAG Test Access Port and Emulation

| Parameter | ADSP-21060 | | ADSP-21060L | | Units |
|-----------------------------------|-------------------------------------------------|-----|-------------|------|-------|
| | Min | Max | Min | Max | |
| <i>Timing Requirements:</i> | | | | | |
| t_{TCK} | TCK Period | | t_{TCK} | | ns |
| t_{STAP} | TDI, TMS Setup before TCK High | | 5 | | ns |
| t_{HTAP} | TDI, TMS Hold after TCK High | | 6 | | ns |
| t_{SSYS} | System Inputs Setup before TCK Low ¹ | | 7 | | ns |
| t_{HSYS} | System Inputs Hold after TCK Low ¹ | | 18 | 18.5 | ns |
| t_{TRSTW} | \overline{TRST} Pulsewidth | | $4t_{CK}$ | | ns |
| <i>Switching Characteristics:</i> | | | | | |
| t_{DTDO} | TDO Delay from TCK Low | | | 13 | ns |
| t_{DSYS} | System Outputs Delay after TCK Low ² | | | 18.5 | ns |

NOTES

¹System Inputs = DATA₄₇₋₀, ADDR₃₁₋₀, \overline{RD} , \overline{WR} , ACK, \overline{SBTS} , \overline{SW} , \overline{HBR} , \overline{HBG} , \overline{CS} , \overline{DMARI} , $\overline{DMAR2}$, \overline{BR}_{6-1} , ID₂₋₀, RPBA, \overline{IRQ}_{2-0} , FLAG₃₋₀, DR0, DR1, TCLK0, TCLK1, RCLK0, RCLK1, TFS0, TFS1, RFS0, RFS1, LxDAT₃₋₀, LxCLK, LxACK, EBOOT, LBOOT, \overline{BMS} , CLKIN, \overline{RESET} .

²System Outputs = DATA₄₇₋₀, ADDR₃₁₋₀, \overline{MS}_{3-0} , \overline{RD} , \overline{WR} , ACK, PAGE, ADRCLK, \overline{SW} , \overline{HBG} , REDI, $\overline{DMAG1}$, $\overline{DMAG2}$, \overline{BR}_{6-1} , CPA, FLAG₃₋₀, TIMEXP, DT0, DT1, TCLK0, TCLK1, RCLK0, RCLK1, TFS0, TFS1, RFS0, RFS1, LxDAT₃₋₀, LxCLK, LxACK, \overline{BMS} .

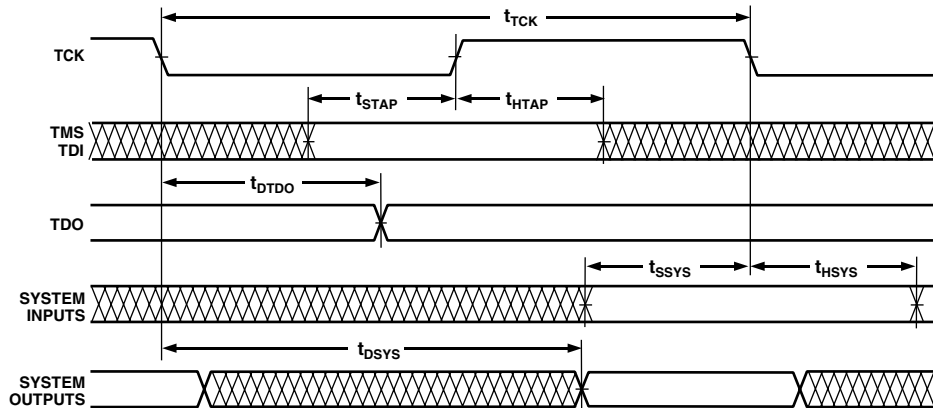

Figure 24. IEEE 1149.1 JTAG Test Access Port

ADSP-21060/ADSP-21060L

OUTPUT DRIVE CURRENTS

Figure 28 shows typical I-V characteristics for the output drivers of the ADSP-2106x. The curves represent the current drive capability of the output drivers as a function of output voltage.

POWER DISSIPATION

Total power dissipation has two components, one due to internal circuitry and one due to the switching of external output drivers. Internal power dissipation is dependent on the instruction execution sequence and the data operands involved. Internal power dissipation is calculated in the following way:

$$P_{INT} = I_{DDIN} \times V_{DD}$$

The external component of total power dissipation is caused by the switching of output pins. Its magnitude depends on:

- the number of output pins that switch during each cycle (O)
- the maximum frequency at which they can switch (f)
- their load capacitance (C)
- their voltage swing (V_{DD})

and is calculated by:

$$P_{EXT} = O \times C \times V_{DD}^2 \times f$$

The load capacitance should include the processor's package capacitance (C_{IN}). The switching frequency includes driving the load high and then back low. Address and data pins can drive high and low at a maximum rate of 1/(2t_{CK}). The write strobe can switch every cycle at a frequency of 1/t_{CK}. Select pins switch at 1/(2t_{CK}), but selects can switch on each cycle.

Example:

Estimate P_{EXT} with the following assumptions:

- A system with one bank of external data memory RAM (32-bit)
- Four 128K × 8 RAM chips are used, each with a load of 10 pF
- External data memory writes occur every other cycle, a rate of 1/(4t_{CK}), with 50% of the pins switching
- The instruction cycle rate is 40 MHz (t_{CK} = 25 ns).

The P_{EXT} equation is calculated for each class of pins that can drive:

Table II. External Power Calculations (5 V Device)

| Pin Type | # of Pins | % Switching | × C | × f | × V _{DD} ² = P _{EXT} |
|----------|-----------|-------------|-----------|----------|---------------------------------------------------|
| Address | 15 | 50 | × 44.7 pF | × 10 MHz | × 25 V = 0.084 W |
| MS0 | 1 | 0 | × 44.7 pF | × 10 MHz | × 25 V = 0.000 W |
| WR | 1 | – | × 44.7 pF | × 20 MHz | × 25 V = 0.022 W |
| Data | 32 | 50 | × 14.7 pF | × 10 MHz | × 25 V = 0.059 W |
| ADDRCLK | 1 | – | × 4.7 pF | × 20 MHz | × 25 V = 0.002 W |

$$P_{EXT} = 0.167 \text{ W}$$

Table III. External Power Calculations (3.3 V Device)

| Pin Type | # of Pins | % Switching | × C | × f | × V _{DD} ² = P _{EXT} |
|----------|-----------|-------------|-----------|----------|---------------------------------------------------|
| Address | 15 | 50 | × 44.7 pF | × 10 MHz | × 10.9 V = 0.037 W |
| MS0 | 1 | 0 | × 44.7 pF | × 10 MHz | × 10.9 V = 0.000 W |
| WR | 1 | – | × 44.7 pF | × 20 MHz | × 10.9 V = 0.010 W |
| Data | 32 | 50 | × 14.7 pF | × 10 MHz | × 10.9 V = 0.026 W |
| ADDRCLK | 1 | – | × 4.7 pF | × 20 MHz | × 10.9 V = 0.001 W |

$$P_{EXT} = 0.074 \text{ W}$$

A typical power consumption can now be calculated for these conditions by adding a typical internal power dissipation:

$$P_{TOTAL} = P_{EXT} + (I_{DDIN2} \times 5.0 \text{ V})$$

Note that the conditions causing a worst-case P_{EXT} are different from those causing a worst-case P_{INT}. Maximum P_{INT} cannot occur while 100% of the output pins are switching from all ones to all zeros. Note also that it is not common for an application to have 100% or even 50% of the outputs switching simultaneously.

TEST CONDITIONS

Output Disable Time

Output pins are considered to be disabled when they stop driving, go into a high impedance state, and start to decay from their output high or low voltage. The time for the voltage on the bus to decay by ΔV is dependent on the capacitive load, C_L and the load current, I_L. This decay time can be approximated by the following equation:

$$t_{DECAY} = \frac{C_L \Delta V}{I_L}$$

The output disable time t_{DIS} is the difference between t_{MEASURED} and t_{DECAY} as shown in Figure 25. The time t_{MEASURED} is the interval from when the reference signal switches to when the output voltage decays ΔV from the measured output high or output low voltage. t_{DECAY} is calculated with test loads C_L and I_L, and with ΔV equal to 0.5 V.

Output Enable Time

Output pins are considered to be enabled when they have made a transition from a high impedance state to when they start driving. The output enable time t_{ENA} is the interval from when a reference signal reaches a high or low voltage level to when the output has reached a specified high or low trip point, as shown in the Output Enable/Disable diagram (Figure 25). If multiple pins (such as the data bus) are enabled, the measurement value is that of the first pin to start driving.

ADSP-21060/ADSP-21060L

Example System Hold Time Calculation

To determine the data output hold time in a particular system, first calculate t_{DECAY} using the equation given above. Choose ΔV to be the difference between the ADSP-2106x's output voltage and the input threshold for the device requiring the hold time. A typical ΔV will be 0.4 V. C_L is the total bus capacitance (per data line), and I_L is the total leakage or three-state current (per data line). The hold time will be t_{DECAY} plus the minimum disable time (i.e., t_{DATRWH} for the write cycle).

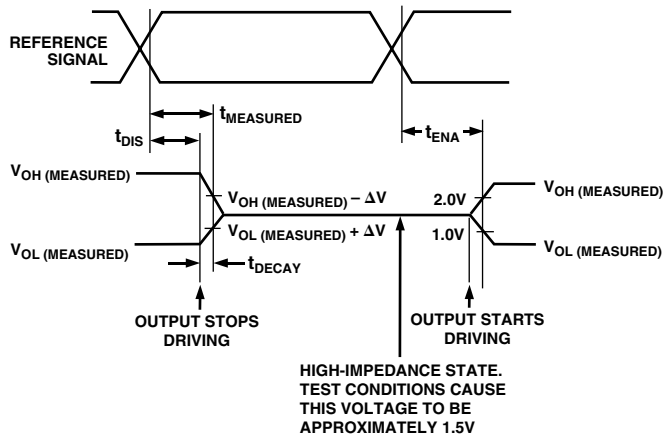

Figure 25. Output Enable/Disable

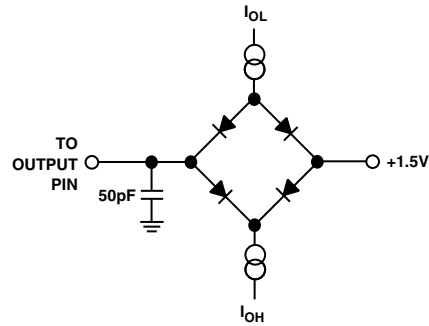

Figure 26. Equivalent Device Loading for AC Measurements (Includes All Fixtures)

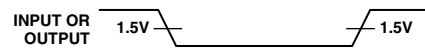

Figure 27. Voltage Reference Levels for AC Measurements (Except Output Enable/Disable)

Capacitive Loading

Output delays and holds are based on standard capacitive loads: 50 pF on all pins (see Figure 26). The delay and hold specifications given should be derated by a factor of 1.5 ns/50 pF for loads other than the nominal value of 50 pF. Figures 29–30, 33–34 show how output rise time varies with capacitance. Figures 31, 35 show graphically how output delays and holds vary with load capacitance. (Note that this graph or derating does not apply to output disable delays; see the previous section *Output Disable Time* under Test Conditions.) The graphs of Figures 29, 30 and 31 may not be linear outside the ranges shown.

ADSP-21060/ADSP-21060L

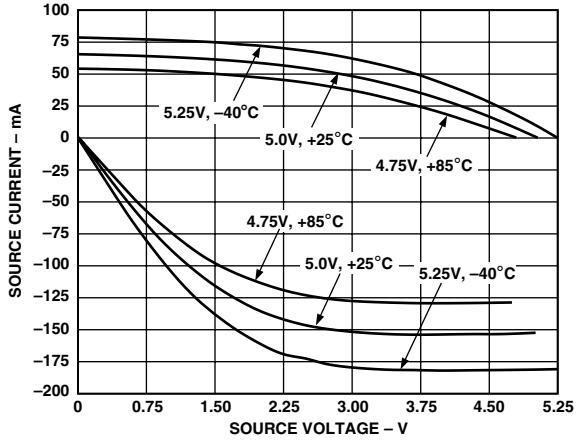

Figure 28. ADSP-2106x Typical Drive Currents ($V_{DD} = 5\text{ V}$)

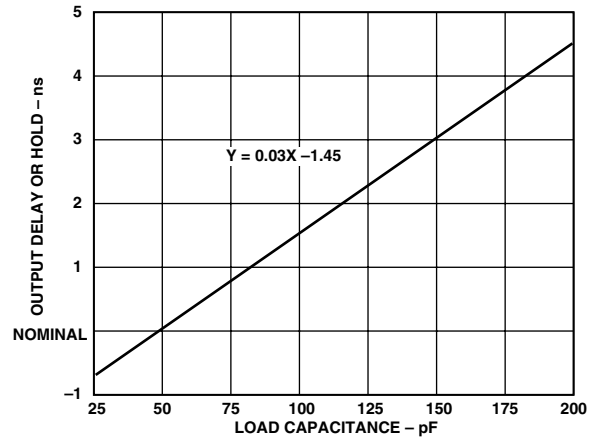

Figure 31. Typical Output Delay or Hold vs. Load Capacitance (at Maximum Case Temperature) ($V_{DD} = 5\text{ V}$)

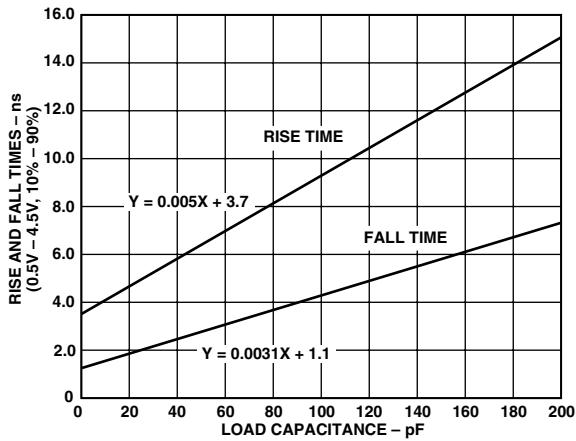

Figure 29. Typical Output Rise Time (10%–90% V_{DD}) vs. Load Capacitance ($V_{DD} = 5\text{ V}$)

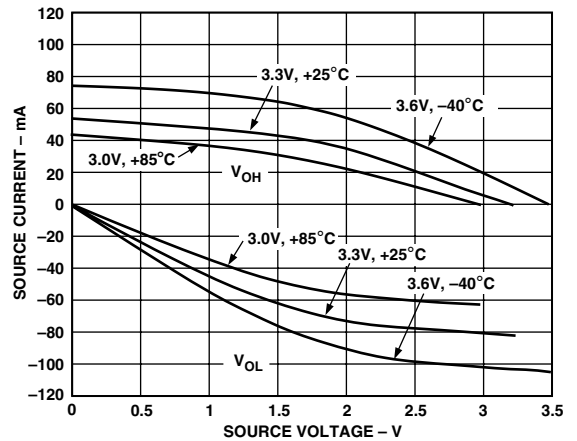

Figure 32. ADSP-2106x Typical Drive Currents ($V_{DD} = 3.3\text{ V}$)

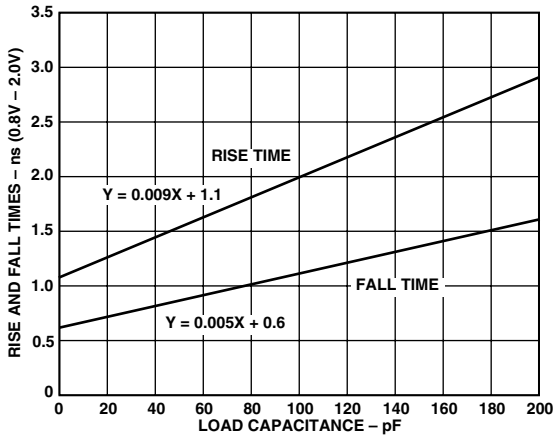

Figure 30. Typical Output Rise Time (0.8 V–2.0 V) vs. Load Capacitance ($V_{DD} = 5\text{ V}$)

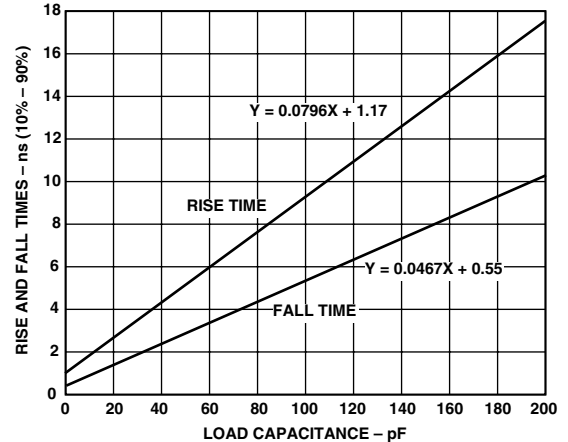

Figure 33. Typical Output Rise Time (10%–90% V_{DD}) vs. Load Capacitance ($V_{DD} = 3.3\text{ V}$)

ADSP-21060/ADSP-21060L

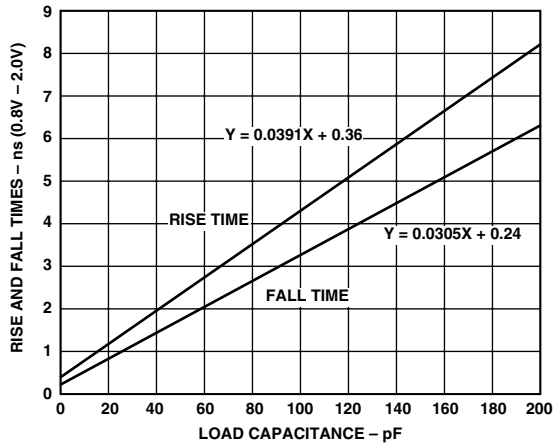

Figure 34. Typical Output Rise Time (0.8 V-2.0 V) vs. Load Capacitance ($V_{DD} = 3.3$ V)

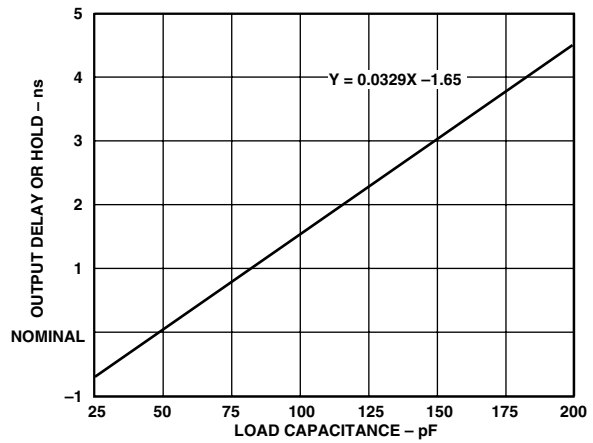

Figure 35. Typical Output Delay or Hold vs. Load Capacitance (at Maximum Case Temperature) ($V_{DD} = 3.3$ V)

ENVIRONMENTAL CONDITIONS

Thermal Characteristics

The ADSP-21060KS and ADSP-21060LKS are packaged in a 240-lead thermally enhanced MQFP. The top surface of the package contains a copper slug from which most of the die heat is dissipated. The slug is flush with the top surface of the package. Note that the copper slug is internally connected to GND through the device substrate. The ADSP-21060KB and ADSP-21060LKB are plastic ball grid arrays. The θ_{JC} for the PBGA package is $1.7^{\circ}\text{C}/\text{Q}$.

The ADSP-2106x is specified for a case temperature (T_{CASE}). To ensure that the T_{CASE} data sheet specification is not exceeded, a heatsink and/or an air flow source may be used. A heatsink should be attached with a thermal adhesive.

$$T_{CASE} = T_{AMB} + (PD \times \theta_{CA})$$

T_{CASE} = Case temperature (measured on top surface of package)
 PD = Power dissipation in W (this value depends upon the specific application; a method for calculating PD is shown under Power Dissipation).
 θ_{CA}, θ_{CA} = Values from table below.

Plastic Quad Flatpack Package

| $\theta_{JC} = 0.3^{\circ}\text{C}/\text{W}$ Airflow (Linear Ft./Min.) | 0 | 100 | 200 | 400 | 600 |
|------------------------------------------------------------------------------|----|-----|-----|-----|-----|
| θ_{CA} ($^{\circ}\text{C}/\text{W}$) | 10 | 9 | 8 | 7 | 6 |

NOTES

This represents thermal resistance at total power of 5 W.

With air flow, no variance is seen in θ_{CA} with power.

θ_{CA} at 0 LFM varies with power: at 2W, $\theta_{CA} = 14^{\circ}\text{C}/\text{W}$, at 3W $\theta_{CA} = 11^{\circ}\text{C}/\text{W}$.

PBGA Package

| $\theta_{JC} = 1.7^{\circ}\text{C}/\text{W}$ Airflow (Linear Ft./Min.) | 0 | 200 | 400 |
|------------------------------------------------------------------------------|------|------|------|
| θ_{CA} ($^{\circ}\text{C}/\text{W}$) | 20.7 | 15.3 | 12.9 |

NOTE

With air flow, no variance is seen in θ_{CA} with power.

ADSP-21060/ADSP-21060L

PACKAGE DIMENSIONS

Dimensions shown in inches and (mm).

240-Lead MQFP

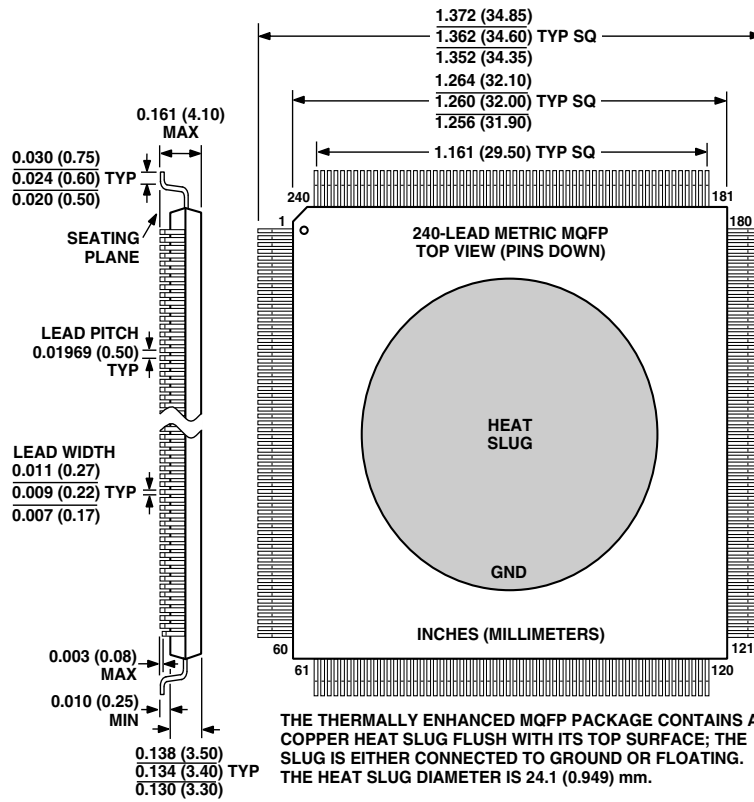

THE THERMALLY ENHANCED MQFP PACKAGE CONTAINS A COPPER HEAT SLUG FLUSH WITH ITS TOP SURFACE; THE SLUG IS EITHER CONNECTED TO GROUND OR FLOATING. THE HEAT SLUG DIAMETER IS 24.1 (0.949) mm.

NOTE:
 THE ACTUAL POSITION OF EACH LEAD IS WITHIN (0.08) 0.0032 FROM ITS IDEAL POSITION WHEN MEASURED IN THE LATERAL DIRECTION.
 CENTER FIGURES ARE TYPICAL UNLESS OTHERWISE NOTED

ADSP-21060/ADSP-21060L

225-Ball Plastic Ball Grid Array (PBGA) Package Pinout

| Ball # | Name | Ball # | Name | Ball # | Name | Ball # | Name | Ball # | Name |
|--------|---------------------------|--------|---------------------------|--------|--------|--------|--------|--------|---------------------------|
| A01 | $\overline{\text{BMS}}$ | D01 | ADDR25 | G01 | ADDR14 | K01 | ADDR6 | N01 | $\overline{\text{EMU}}$ |
| A02 | ADDR30 | D02 | ADDR26 | G02 | ADDR15 | K02 | ADDR5 | N02 | TDO |
| A03 | $\overline{\text{DMAR2}}$ | D03 | $\overline{\text{MS2}}$ | G03 | ADDR16 | K03 | ADDR3 | N03 | $\overline{\text{IRQ0}}$ |
| A04 | DT1 | D04 | ADDR29 | G04 | ADDR19 | K04 | ADDR0 | N04 | $\overline{\text{IRQ1}}$ |
| A05 | RCLK1 | D05 | $\overline{\text{DMAR1}}$ | G05 | GND | K05 | ICSA | N05 | ID2 |
| A06 | TCLK0 | D06 | $\overline{\text{TFS1}}$ | G06 | VDD | K06 | GND | N06 | L5DAT1 |
| A07 | $\overline{\text{RCLK0}}$ | D07 | $\overline{\text{CPA}}$ | G07 | VDD | K07 | VDD | N07 | L4CLK |
| A08 | ADRCLK | D08 | $\overline{\text{HBG}}$ | G08 | VDD | K08 | VDD | N08 | L3CLK |
| A09 | $\overline{\text{CS}}$ | D09 | $\overline{\text{DMAG2}}$ | G09 | VDD | K09 | VDD | N09 | L3DAT3 |
| A10 | CLKIN | D10 | $\overline{\text{BR5}}$ | G10 | VDD | K10 | GND | N10 | L2DAT0 |
| A11 | $\overline{\text{PAGE}}$ | D11 | $\overline{\text{BR1}}$ | G11 | GND | K11 | GND | N11 | L1ACK |
| A12 | $\overline{\text{BR3}}$ | D12 | DATA40 | G12 | DATA22 | K12 | DATA8 | N12 | L1DAT3 |
| A13 | DATA47 | D13 | DATA37 | G13 | DATA25 | K13 | DATA11 | N13 | L0DAT3 |
| A14 | DATA44 | D14 | DATA35 | G14 | DATA24 | K14 | DATA13 | N14 | DATA1 |
| A15 | DATA42 | D15 | DATA34 | G15 | DATA23 | K15 | DATA14 | N15 | DATA3 |
| B01 | $\overline{\text{MS0}}$ | E01 | ADDR21 | H01 | ADDR12 | L01 | ADDR2 | P01 | $\overline{\text{TRST}}$ |
| B02 | $\overline{\text{SW}}$ | E02 | ADDR22 | H02 | ADDR11 | L02 | ADDR1 | P02 | TMS |
| B03 | ADDR31 | E03 | ADDR24 | H03 | ADDR13 | L03 | FLAG0 | P03 | EBOOT |
| B04 | $\overline{\text{HBR}}$ | E04 | ADDR27 | H04 | ADDR10 | L04 | FLAG3 | P04 | ID0 |
| B05 | DR1 | E05 | GND | H05 | GND | L05 | RPBA | P05 | L5CLK |
| B06 | DT0 | E06 | GND | H06 | VDD | L06 | GND | P06 | L5DAT3 |
| B07 | DR0 | E07 | GND | H07 | VDD | L07 | GND | P07 | L4DAT0 |
| B08 | REDY | E08 | GND | H08 | VDD | L08 | GND | P08 | L4DAT3 |
| B09 | $\overline{\text{RD}}$ | E09 | GND | H09 | VDD | L09 | GND | P09 | L3DAT2 |
| B10 | ACK | E10 | GND | H10 | VDD | L10 | GND | P10 | L2CLK |
| B11 | $\overline{\text{BR6}}$ | E11 | NC | H11 | GND | L11 | NC | P11 | L2DAT2 |
| B12 | $\overline{\text{BR2}}$ | E12 | DATA33 | H12 | DATA18 | L12 | DATA4 | P12 | L1DAT0 |
| B13 | DATA45 | E13 | DATA30 | H13 | DATA19 | L13 | DATA7 | P13 | L0ACK |
| B14 | DATA43 | E14 | DATA32 | H14 | DATA21 | L14 | DATA9 | P14 | L0DAT1 |
| B15 | DATA39 | E15 | DATA31 | H15 | DATA20 | L15 | DATA10 | P15 | DATA0 |
| C01 | $\overline{\text{MS3}}$ | F01 | ADDR17 | J01 | ADDR9 | M01 | FLAG1 | R01 | TCK |
| C02 | $\overline{\text{MS1}}$ | F02 | ADDR18 | J02 | ADDR8 | M02 | FLAG2 | R02 | $\overline{\text{IRQ2}}$ |
| C03 | ADDR28 | F03 | ADDR20 | J03 | ADDR7 | M03 | TIMEXP | R03 | $\overline{\text{RESET}}$ |
| C04 | SBTS | F04 | ADDR23 | J04 | ADDR4 | M04 | TDI | R04 | ID1 |
| C05 | TCLK1 | F05 | GND | J05 | GND | M05 | LBOOT | R05 | L5DAT0 |
| C06 | RFS1 | F06 | GND | J06 | VDD | M06 | L5ACK | R06 | L4ACK |
| C07 | TFS0 | F07 | VDD | J07 | VDD | M07 | L5DAT2 | R07 | L4DAT1 |
| C08 | RFS0 | F08 | VDD | J08 | VDD | M08 | L4DAT2 | R08 | L3ACK |
| C09 | $\overline{\text{WR}}$ | F09 | VDD | J09 | VDD | M09 | L3DAT0 | R09 | L3DAT1 |
| C10 | $\overline{\text{DMAG1}}$ | F10 | GND | J10 | VDD | M10 | L2DAT3 | R10 | L2ACK |
| C11 | $\overline{\text{BR4}}$ | F11 | GND | J11 | GND | M11 | L1DAT1 | R11 | L2DAT1 |
| C12 | DATA46 | F12 | DATA29 | J12 | DATA12 | M12 | L0DAT0 | R12 | L1CLK |
| C13 | DATA41 | F13 | DATA26 | J13 | DATA15 | M13 | DATA2 | R13 | L1DAT2 |
| C14 | DATA38 | F14 | DATA28 | J14 | DATA16 | M14 | DATA5 | R14 | L0CLK |
| C15 | DATA36 | F15 | DATA27 | J15 | DATA17 | M15 | DATA6 | R15 | L0DAT2 |

ADSP-21060/ADSP-21060L

225-Plastic Ball Grid Array (PBGA) Package Pinout

Bottom View

| 15 | 14 | 13 | 12 | 11 | 10 | 9 | 8 | 7 | 6 | 5 | 4 | 3 | 2 | 1 | |
|--------|--------|--------|--------------------------|--------------------------|----------------------------|----------------------------|-------------------------|-------------------------|--------|----------------------------|---------------------------|----------------------------|---------------------------|--------------------------|---|
| DATA42 | DATA44 | DATA47 | $\overline{\text{BR}}_3$ | PAGE | CLKIN | $\overline{\text{CS}}$ | ADRCLK | RCLK0 | TCLK0 | RCLK1 | DT1 | $\overline{\text{DMAR}}_2$ | ADDR30 | $\overline{\text{BMS}}$ | A |
| DATA39 | DATA43 | DATA45 | $\overline{\text{BR}}_2$ | $\overline{\text{BR}}_6$ | ACK | $\overline{\text{RD}}$ | REDY | DR0 | DT0 | DR1 | $\overline{\text{HBR}}$ | ADDR31 | $\overline{\text{SW}}$ | $\overline{\text{MS}}_0$ | B |
| DATA36 | DATA38 | DATA41 | DATA46 | $\overline{\text{BR}}_4$ | $\overline{\text{DMAG}}_1$ | $\overline{\text{WR}}$ | RFS0 | TFS0 | RFS1 | TCLK1 | $\overline{\text{SBTS}}$ | ADDR28 | $\overline{\text{MST}}$ | $\overline{\text{MS}}_3$ | C |
| DATA34 | DATA35 | DATA37 | DATA40 | $\overline{\text{BR}}_1$ | $\overline{\text{BR}}_5$ | $\overline{\text{DMAG}}_2$ | $\overline{\text{HBG}}$ | $\overline{\text{CPA}}$ | TFS1 | $\overline{\text{DMAR}}_1$ | ADDR29 | $\overline{\text{MS}}_2$ | ADDR26 | ADDR25 | D |
| DATA31 | DATA32 | DATA30 | DATA33 | NC | GND | GND | GND | GND | GND | GND | ADDR27 | ADDR24 | ADDR22 | ADDR21 | E |
| DATA27 | DATA28 | DATA26 | DATA29 | GND | GND | VDD | VDD | VDD | GND | GND | ADDR23 | ADDR20 | ADDR18 | ADDR17 | F |
| DATA23 | DATA24 | DATA25 | DATA22 | GND | VDD | VDD | VDD | VDD | VDD | GND | ADDR19 | ADDR16 | ADDR15 | ADDR14 | G |
| DATA20 | DATA21 | DATA19 | DATA18 | GND | VDD | VDD | VDD | VDD | VDD | GND | ADDR10 | ADDR13 | ADDR11 | ADDR12 | H |
| DATA17 | DATA16 | DATA15 | DATA12 | GND | VDD | VDD | VDD | VDD | VDD | GND | ADDR4 | ADDR7 | ADDR8 | ADDR9 | J |
| DATA14 | DATA13 | DATA11 | DATA8 | GND | GND | VDD | VDD | VDD | GND | ICSA | ADDR0 | ADDR3 | ADDR5 | ADDR6 | K |
| DATA10 | DATA9 | DATA7 | DATA4 | NC | GND | GND | GND | GND | GND | RPBA | FLAG3 | FLAG0 | ADDR1 | ADDR2 | L |
| DATA6 | DATA5 | DATA2 | L0DAT0 | L1DAT1 | L2DAT3 | L3DAT0 | L4DAT2 | L5DAT2 | L5ACK | LBOOT | TDI | TIMEXP | FLAG2 | FLAG1 | M |
| DATA3 | DATA1 | L0DAT3 | L1DAT3 | L1ACK | L2DAT0 | L3DAT3 | L3CLK | L4CLK | L5DAT1 | ID2 | $\overline{\text{IRQ}}_1$ | $\overline{\text{IRQ}}_0$ | TDO | $\overline{\text{EMU}}$ | N |
| DATA0 | L0DAT1 | L0ACK | L1DAT0 | L2DAT2 | L2CLK | L3DAT2 | L4DAT3 | L4DAT0 | L5DAT3 | L5CLK | ID0 | EBOOT | TMS | $\overline{\text{TRST}}$ | P |
| L0DAT2 | L0CLK | L1DAT2 | L1CLK | L2DAT1 | L2ACK | L3DAT1 | L3ACK | L4DAT1 | L4ACK | L5DAT0 | ID1 | $\overline{\text{RESET}}$ | $\overline{\text{IRQ}}_2$ | TCK | R |

ADSP-21060/ADSP-21060L

PACKAGE DIMENSIONS

Dimensions shown in inches and (mm).

225-Plastic Ball Grid Array (PBGA)

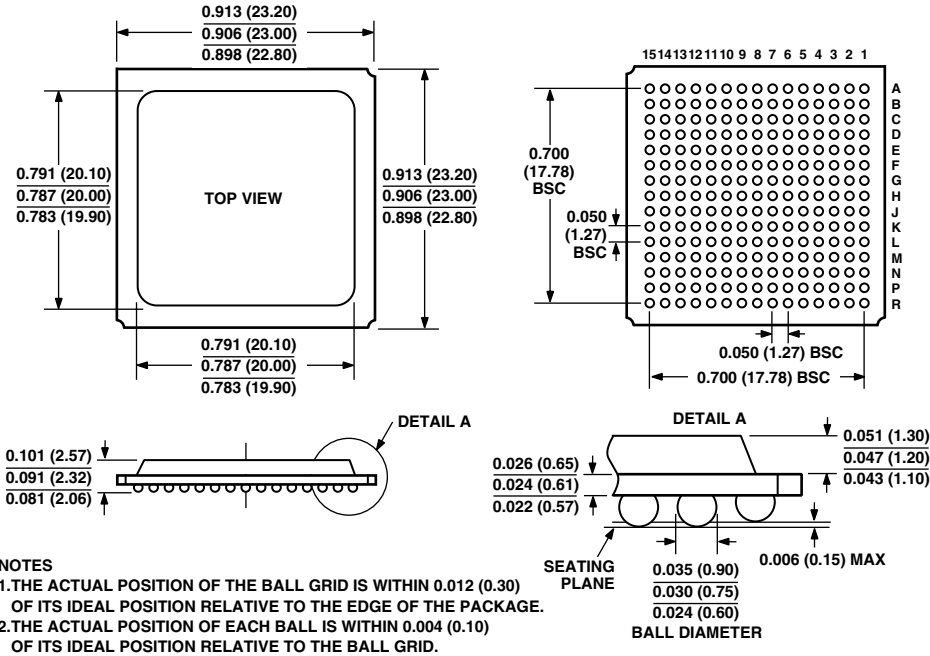

ORDERING GUIDE

| Part Number | Case Temperature Range | Instruction Rate | On-Chip SRAM | Operating Voltage | Package Options |
|-------------------|------------------------|------------------|--------------|-------------------|-----------------|
| ADSP-21060KS-133 | 0°C to +85°C | 33 MHz | 4 Mbit | 5 V | MQFP |
| ADSP-21060KS-160 | 0°C to +85°C | 40 MHz | 4 Mbit | 5 V | MQFP |
| ADSP-21060KB-160 | 0°C to +85°C | 40 MHz | 4 Mbit | 5 V | PBGA |
| ADSP-21060LKS-133 | 0°C to +85°C | 33 MHz | 4 Mbit | 3.3 V | MQFP |
| ADSP-21060LKS-160 | 0°C to +85°C | 40 MHz | 4 Mbit | 3.3 V | MQFP |
| ADSP-21060LKB-160 | 0°C to +85°C | 40 MHz | 4 Mbit | 3.3 V | PBGA |
| ADSP-21060LAB-160 | -40°C to +85°C | 40 MHz | 4 Mbit | 3.3 V | PBGA |