



Low Input Voltage Current Mode Step-Down DC/DC Controller

December 1998

FEATURES

- High Efficiency
- Constant Frequency 550kHz Operation
- V_{IN} Range: 2V to 10V
- Multiampere Output Currents
- Synchronizable up to 750kHz
- Selectable Burst Mode Operation
- Low Dropout Operation: 100% Duty Cycle
- Current Mode Operation for Excellent Line and Load Transient Response
- Low Quiescent Current: 350 μ A
- Shutdown Mode Draws Only 15 μ A Supply Current
- $\pm 2.5\%$ Reference Accuracy
- Available in 8-Lead MSOP

APPLICATIONS

- One or Two Lithium-Ion-Powered Applications
- Cellular Telephones
- Wireless Modems
- RF Communications
- Distributed 3.3V, 2.5V or 1.8V Power Systems
- Scanners
- Battery-Powered Equipment

DESCRIPTION

The LTC[®]1622 is a constant frequency current mode step-down DC/DC controller providing excellent AC and DC load and line regulation. The device incorporates an accurate undervoltage feature that shuts the LTC1622 down when the input voltage falls below 2V.

The LTC1622 boasts a $\pm 2.5\%$ output voltage accuracy and consumes only 350 μ A of quiescent current. For applications where efficiency is a prime consideration and the load current varies from light to heavy, the LTC1622 can be configured for Burst Mode™ operation. Burst Mode operation enhances low current efficiency.

Burst Mode operation is inhibited during synchronization or when the SYNC/MODE pin is pulled low to reduce noise and RF interference.

High constant operating frequency of 550kHz allows the use of a small inductor. The device can also be synchronized up to 750kHz for special applications.

To further maximize the life of the battery source, the P-channel MOSFET is turned on continuously in dropout (100% duty cycle). In shutdown, the device draws a mere 15 μ A. The LTC1622 is available in a small footprint 8-lead MSOP.

LT, LTC and LT are registered trademarks of Linear Technology Corporation. Burst Mode is a trademark of Linear Technology Corporation.

TYPICAL APPLICATION

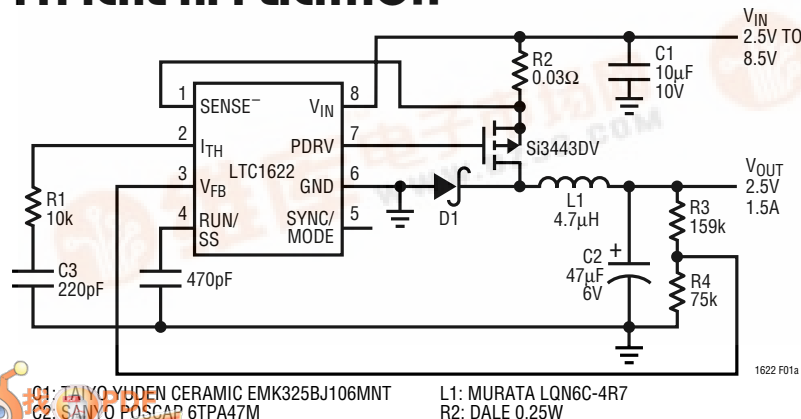

Efficiency vs Load Current with
Burst Mode Operation Enabled

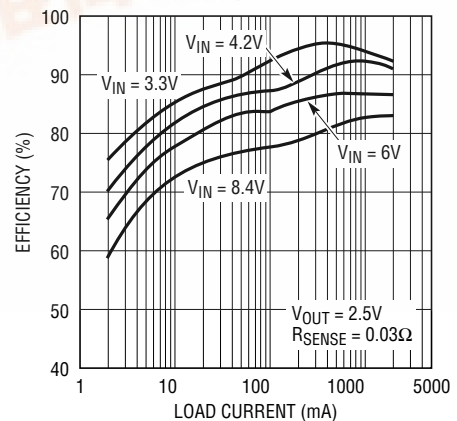

Figure 1. High Efficiency Step-Down Converter

LTC1622

ABSOLUTE MAXIMUM RATINGS (Note 1)

Input Supply Voltage (V_{IN})	–0.3V to 10V	Storage Ambient Temperature Range	–65°C to 150°C
RUN/SS, V_{FB} Voltages	–0.3V to 2.4V	Operating Temperature Range	
I_{TH} Voltage	–0.3V to 5V	Commercial	0°C to 70°C
SYNC/MODE Voltage	–0.3V to V_{IN}	Junction Temperature (Note 2)	125°C
SENSE ⁻ Voltage	2.4V to ($V_{IN} + 0.3V$)	Lead Temperature (Soldering, 10 sec)	300°C
PDRV Peak Output Current (<10 μ s)	1A		

PACKAGE/ORDER INFORMATION

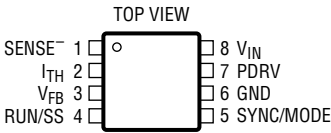
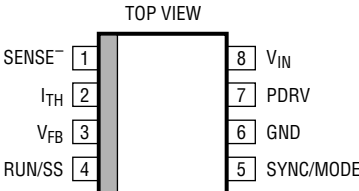
 <p>TOP VIEW</p> <p>SENSE⁻ 1 □ 8 V_{IN}</p> <p>I_{TH} 2 □ 7 PDRV</p> <p>V_{FB} 3 □ 6 GND</p> <p>RUN/SS 4 □ 5 SYNC/MODE</p> <p>MS8 PACKAGE 8-LEAD PLASTIC MSOP</p> <p>$T_{JMAX} = 125^{\circ}C, \theta_{JA} = 250^{\circ}C/W$</p>	ORDER PART NUMBER	 <p>TOP VIEW</p> <p>SENSE⁻ 1 □ 8 V_{IN}</p> <p>I_{TH} 2 □ 7 PDRV</p> <p>V_{FB} 3 □ 6 GND</p> <p>RUN/SS 4 □ 5 SYNC/MODE</p> <p>S8 PACKAGE 8-LEAD PLASTIC SO</p> <p>$T_{JMAX} = 125^{\circ}C, \theta_{JA} = 150^{\circ}C/W$</p>	ORDER PART NUMBER
	LTC1622CMS8		LTC1622CS8
	MS8 PART MARKING		S8 PART MARKING
	LTDB		1622

Consult factory for Industrial and Military grade parts.

ELECTRICAL CHARACTERISTICS $T_A = 25^{\circ}C, V_{IN} = 4.2V$ unless otherwise specified.

SYMBOL	PARAMETER	CONDITIONS	MIN	TYP	MAX	UNITS
I_{VFB}	Feedback Current	(Note 3)		10	70	nA
V_{FB}	Regulated Feedback Voltage	(Note 3)	● 0.78	0.8	0.82	V
V_{OVL}	Output Overvoltage Lockout		0.82	0.86	0.895	V
ΔV_{OSENSE}	Reference Voltage Line Regulation	$V_{IN} = 4.2V$ to 10V (Note 3)		0.04		%/V
$V_{LOADREG}$	Output Voltage Load Regulation	Measured in Servo Loop; $V_{ITH} = 0.2V$ Measured in Servo Loop; $V_{ITH} = 0.9V$		0.3 –0.3		% %
I_S	Input DC Supply Current	(Note 4)				
	Burst Mode Inhibited	$2.65V < V_{IN} < 10V$		450		μA
	Sleep Mode	$V_{ITH} = 0V, 2.65V < V_{IN} < 10V, V_{SYNC/MODE} = 2V$		350		μA
	Shutdown	$V_{RUN/SS} = 0V, 2.65V < V_{IN} < 10V$		15	50	μA
	Shutdown	$V_{RUN/SS} = 0V, V_{IN} < 2.4V$		4		μA
$V_{RUN/SS}$	RUN/SS Threshold		● 0.4	0.7	1.0	V
$I_{RUN/SS}$	Soft Start Current Source	$V_{RUN/SS} = 0V$		0.75		μA
f_{OSC}	Oscillator Frequency	$V_{FB} = 0.8V$ $V_{FB} = 0V$		550 110		kHz kHz
$V_{SYNC/MODE}$	SYNC/MODE Threshold	$V_{SYNC/MODE}$ Ramping Down		1		V
V_{UVLO}	Undervoltage Lockout	V_{IN} Ramping Down V_{IN} Ramping Up	● 1.55	1.92 1.97	2.3 2.36	V V

ELECTRICAL CHARACTERISTICS $T_A = 25^\circ\text{C}$, $V_{IN} = 4.2\text{V}$ unless otherwise specified.

SYMBOL	PARAMETER	CONDITIONS	MIN	TYP	MAX	UNITS
PDRV t_r	Gate Drive Rise Time	$C_{LOAD} = 3000\text{pF}$		80		ns
PDRV t_f	Gate Drive Fall Time	$C_{LOAD} = 3000\text{pF}$		100		ns
$\Delta V_{SENSE(MAX)}$	Maximum Current Sense Voltage			100		mV

The ● denotes specifications that apply over the full operating temperature range.

Note 1: Absolute Maximum Ratings are those values beyond which the life of a device may be impaired.

Note 2: T_J is calculated from the ambient temperature T_A and power dissipation P_D according to the following formula:

$$\text{LTC1622CS8}; T_J = T_A + (P_D \cdot 150^\circ\text{C/W}),$$

$$\text{LTC1622CMS8}; T_J = T_A + (P_D \cdot 250^\circ\text{C/W})$$

Note 3: The LTC1622 is tested in a feedback loop that servos V_{FB} to the feedback point for the error amplifier ($V_{TH} = 0.8\text{V}$).

Note 4: Dynamic supply current is higher due to the gate charge being delivered at the switching frequency.

TYPICAL PERFORMANCE CHARACTERISTICS

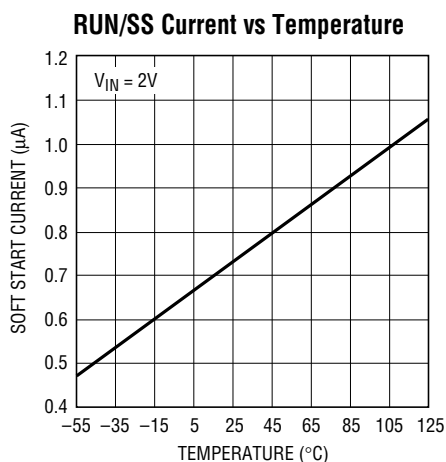

1622 G01

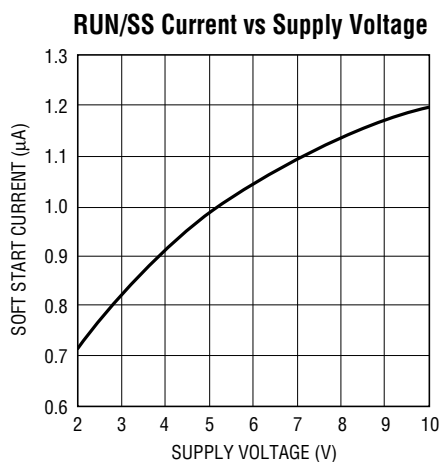

1622 G02

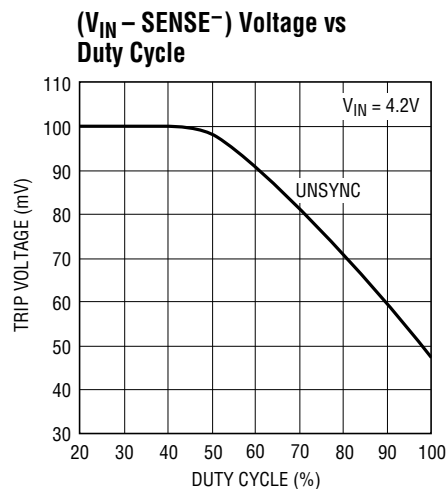

1622 G03

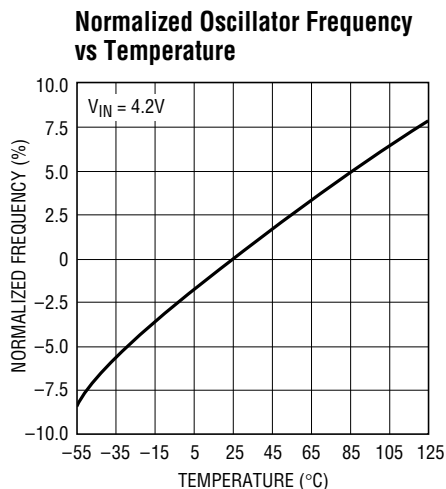

1622 G04

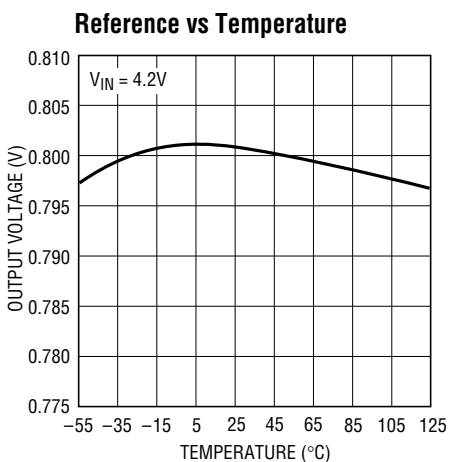

1622 G05

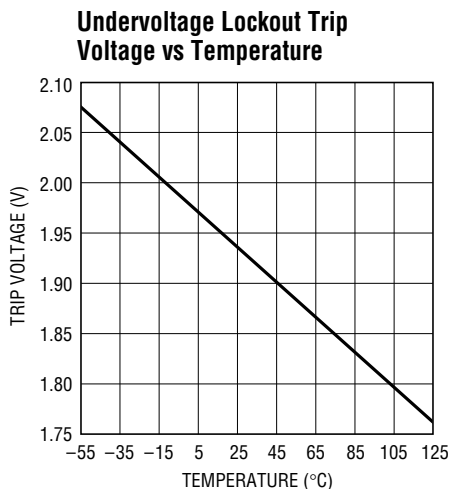

1622 G06

TYPICAL PERFORMANCE CHARACTERISTICS

Efficiency vs Load Current for Figure 1 with Burst Mode Operation Defeated

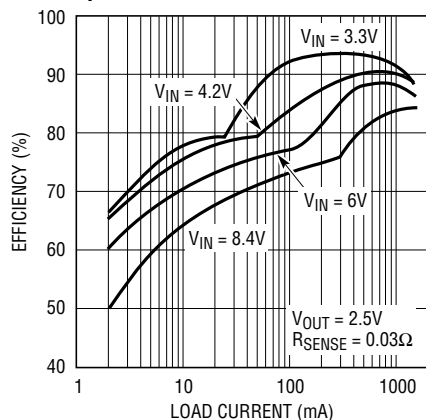

Transient Response Burst Enabled

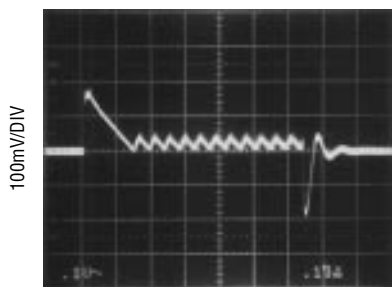

$I_{LOAD} = 50\text{mA TO } 1.2\text{A}$
 $V_{IN} = 4.2\text{V}$

Transient Response Burst Inhibited



$I_{LOAD} = 50\text{mA TO } 1.2\text{A}$
 $V_{IN} = 4.2\text{V}$

PIN FUNCTIONS

SENSE⁻ (Pin 1): The Negative Input to the Current Comparator.

I_{TH} (Pin 2): Error Amplifier Compensation Point. The current comparator threshold increases with this control voltage. Nominal voltage range for this pin is 0V to 1.2V.

V_{FB} (Pin 3): Receives the feedback voltage from an external resistive divider across the output capacitor.

RUN/SS (Pin 4): Combination of Soft Start and Run Control Inputs. A capacitor to ground at this pin sets the ramp time to full output current. The time is approximately $1.5\text{s}/\mu\text{F}$. Forcing this pin below 0.4V causes all circuitry to be shut down.

SYNC/MODE (Pin 5): This pin performs three functions. Greater than 2V on this pin allows Burst Mode operation at low load currents, while grounding or applying a clock signal on this pin defeats Burst Mode operation. An external clock between 550kHz and 750kHz applied to this pin forces the LTC1622 to operate at the external clock frequency. *Do not attempt to synchronize below 550kHz.* Pin 5 has an internal $1\mu\text{A}$ pull-up current source.

GND (Pin 6): Ground Pin.

PDRV (Pin 7): Gate Drive for the External P-Channel MOSFET. This pin swings from 0V to V_{IN} .

V_{IN} (Pin 8): Main Supply Pin. Must be closely decoupled to ground Pin 6.

FUNCTIONAL DIAGRAM

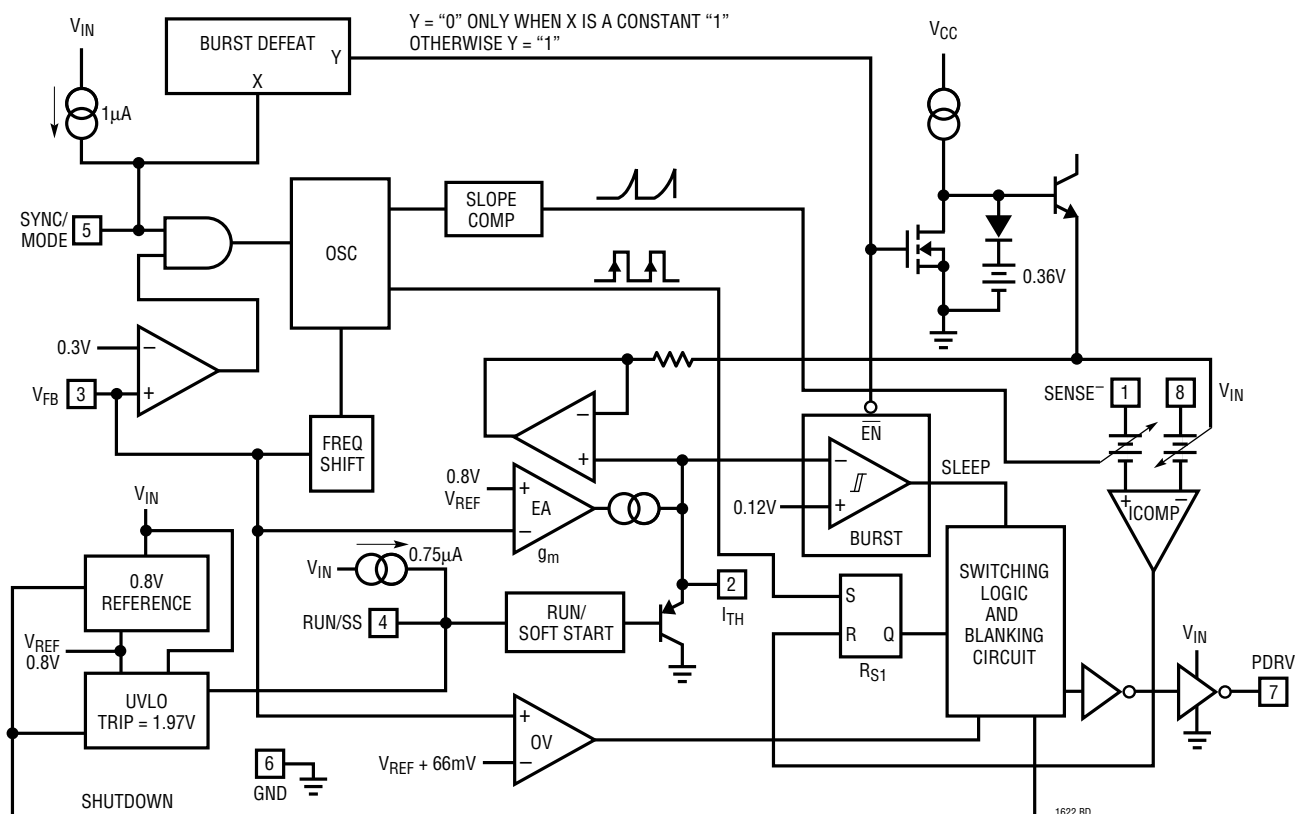

OPERATION (Refer to Functional Diagram)

Main Control Loop

The LTC1622 is a constant frequency current mode switching regulator. During normal operation, the external P-channel power MOSFET is turned on each cycle when the oscillator sets the R_S latch (R_{S1}) and turned off when the current comparator (ICOMP) resets the latch. The peak inductor current at which ICOMP resets the R_S latch is controlled by the voltage on the I_{TH} pin, which is the output of the error amplifier EA. An external resistive divider connected between V_{OUT} and ground allows EA to receive an output feedback voltage V_{FB} . When the load current increases, it causes a slight decrease in V_{FB} relative to the 0.8V reference, which in turn causes the I_{TH} voltage to increase until the average inductor current matches the new load current.

The main control loop is shut down by pulling RUN/SS pin low. Releasing RUN/SS allows an internal $0.75\mu\text{A}$ current

source to charge up the soft start capacitor C_{SS} . When C_{SS} reaches 0.7V, the main control loop is enabled with the I_{TH} voltage clamped at approximately 5% of its maximum value. As C_{SS} continues to charge, I_{TH} is gradually released allowing normal operation to resume.

Comparator 0V guards against transient overshoots $> 8.3\%$ by turning off the P-channel power MOSFET and keeping it off until the fault is removed.

Burst Mode Operation

The LTC1622 can be enabled to go into Burst Mode operation at low load currents simply by leaving the SYNC/MODE pin open or connecting it to a voltage of at least 2V. In this mode, the peak current of the inductor is set as if $V_{I_{TH}} = 0.36\text{V}$ (at low duty cycles) even though the voltage at the I_{TH} pin is at lower value. If the inductor's average current is greater than the load requirement, the voltage at the I_{TH} pin will drop. When the I_{TH} voltage goes below

LTC1622

OPERATION (Refer to Functional Diagram)

0.12V, the sleep signal goes high, turning off the external MOSFET. The sleep signal goes low when the I_{TH} voltage goes above 0.22V and the LTC1622 resumes normal operation. The next oscillator cycle will turn the external MOSFET on and the switching cycle repeats.

Frequency Synchronization

The LTC1622 can be externally driven by a TTL/CMOS compatible clock signal up to 750kHz. *Do not* synchronize the LTC1622 below its default operating frequency of 550kHz as this may cause abnormal operation and an undesired frequency spectrum.

Synchronization is inhibited when the feedback voltage is below 0.3V. This is to prevent inductor current buildup under short-circuit conditions. Burst Mode operation is deactivated when the LTC1622 is externally driven by a clock.

Dropout Operation

When the input supply voltage decreases towards the output voltage, the rate of change of inductor current during the ON cycle decreases. This reduction means that the P-channel MOSFET will remain on for more than one oscillator cycle since the inductor current has not ramped up to the threshold set by EA. Further reduction in input supply voltage will eventually cause the P-channel MOSFET to be turned on 100%, i.e., DC. The output voltage will then be determined by the input voltage minus the voltage drop across the MOSFET, the sense resistor and the inductor.

Undervoltage Lockout

To prevent operation of the P-channel MOSFET below safe input voltage levels, an undervoltage lockout is incorporated into the LTC1622. When the input supply voltage drops to 2V, the P-channel MOSFET and all circuitry is turned off except the undervoltage block, which draws only several microamperes.

Short-Circuit Protection

When the output is shorted to ground, the frequency of the oscillator will be reduced to about 110kHz. This lower frequency allows the inductor current to safely discharge,

thereby preventing current runaway. The oscillator's frequency will gradually increase to its designed rate when the feedback voltage increases above 0.65V. Note that synchronization is inhibited until the feedback voltage goes above 0.3V.

Overvoltage Protection

As a further protection, the overvoltage comparator in the LTC1622 will turn the external MOSFET off when the feedback voltage has risen 8.3% above the reference voltage of 0.8V. This comparator has a typical hysteresis of 35mV.

Slope Compensation and Inductor's Peak Current

The inductor's peak current is determined by:

$$I_{PK} = \frac{V_{ITH}}{10(R_{SENSE})}$$

when the LTC1622 is operating below 40% duty cycle. However, once the duty cycle exceeds 40%, slope compensation begins and effectively reduces the peak inductor current. The amount of reduction is given by the curves in Figure 2.

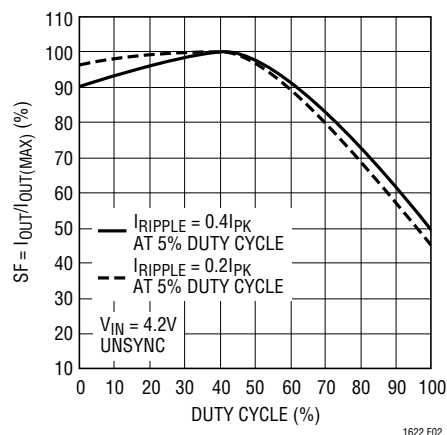

Figure 2. Maximum Output Current vs Duty Cycle

APPLICATIONS INFORMATION

The basic LTC1622 application circuit is shown in Figure 1. External component selection is driven by the load requirement and begins with the selection of L and R_{SENSE}. Next, the Power MOSFET and the output diode D1 is selected followed by C_{IN} and C_{OUT}.

R_{SENSE} Selection for Output Current

R_{SENSE} is chosen based on the required output current. With the current comparator monitoring the voltage developed across R_{SENSE}, the threshold of the comparator determines the inductor's peak current. The output current the LTC1622 can provide is given by:

$$I_{OUT} = \frac{0.08}{R_{SENSE}} - \frac{I_{RIPPLE}}{2}$$

where I_{RIPPLE} is the inductor peak-to-peak ripple current (see Inductor Value Calculation section).

A reasonable starting point for setting ripple current is I_{RIPPLE} = (0.4)(I_{OUT}). Rearranging the above equation, it becomes:

$$R_{SENSE} = \frac{1}{(15)(I_{OUT})} \text{ for Duty Cycle} < 40\%$$

However, for operation that is above 40% duty cycle, slope compensation effect has to be taken into consideration to select the appropriate value to provide the required amount of current. Using Figure 2, the value of R_{SENSE} is:

$$R_{SENSE} = \frac{SF}{(15)(I_{OUT})(100)}$$

Inductor Value Calculation

The operating frequency and inductor selection are inter-related in that higher operating frequencies permit the use of a smaller inductor for the same amount of inductor ripple current. However, this is at the expense of efficiency due to an increase in MOSFET gate charge losses.

The inductance value also has a direct effect on ripple current. The ripple current, I_{RIPPLE}, decreases with higher

inductance or frequency and increases with higher V_{IN} or V_{OUT}. The inductor's peak-to-peak ripple current is given by:

$$I_{RIPPLE} = \frac{V_{IN} - V_{OUT}}{f(L)} \left(\frac{V_{OUT} + V_D}{V_{IN} + V_D} \right)$$

where f is the operating frequency. Accepting larger values of I_{RIPPLE} allows the use of low inductances, but results in higher output voltage ripple and greater core losses. A reasonable starting point for setting ripple current is I_{RIPPLE} = 0.4(I_{OUT(MAX)}). Remember, the maximum I_{RIPPLE} occurs at the maximum input voltage.

With Burst Mode operation selected on the LTC1622, the ripple current is normally set such that the inductor current is continuous during the burst periods. Therefore, the peak-to-peak ripple current must not exceed:

$$I_{RIPPLE} \leq \frac{0.036}{R_{SENSE}}$$

This implies a minimum inductance of:

$$L_{MIN} = \frac{V_{IN} - V_{OUT}}{f \left(\frac{0.036}{R_{SENSE}} \right)} \left(\frac{V_{OUT} + V_D}{V_{IN} + V_D} \right)$$

(Use V_{IN(MAX)} = V_{IN})

A smaller value than L_{MIN} could be used in the circuit; however, the inductor current will not be continuous during burst periods.

Inductor Core Selection

Once the value for L is known, the type of inductor must be selected. High efficiency converters generally cannot afford the core loss found in low cost powdered iron cores, forcing the use of more expensive ferrite, molypermalloy or Kool Mu® cores. Actual core loss is independent of core size for a fixed inductor value, but it is very dependent on inductance selected. As inductance increases, core losses go down. Unfortunately, increased inductance requires more turns of wire and therefore copper losses will

APPLICATIONS INFORMATION

increase. Ferrite designs have very low core losses and are preferred at high switching frequencies, so design goals can concentrate on copper loss and preventing saturation. Ferrite core material saturates “hard,” which means that inductance collapses abruptly when the peak design current is exceeded. This results in an abrupt increase in inductor ripple current and consequent output voltage ripple. Do not allow the core to saturate!

Molypermalloy (from Magnetics, Inc.) is a very good, low loss core material for toroids, but it is more expensive than ferrite. A reasonable compromise from the same manufacturer is Kool Mu. Toroids are very space efficient, especially when you can use several layers of wire. Because they generally lack a bobbin, mounting is more difficult. However, new designs for surface mount that do not increase the height significantly are available.

Power MOSFET Selection

An external P-channel power MOSFET must be selected for use with the LTC1622. The main selection criteria for the power MOSFET are the threshold voltage $V_{GS(TH)}$ and the “on” resistance $R_{DS(ON)}$, reverse transfer capacitance C_{RSS} and total gate charge.

Since the LTC1622 is designed for operation down to low input voltages, a sublogic level threshold MOSFET ($R_{DS(ON)}$ guaranteed at $V_{GS} = 2.5V$) is required for applications that work close to this voltage. When these MOSFETs are used, make sure that the input supply to the LTC1622 is less than the absolute maximum V_{GS} rating, typically 8V.

The required minimum $R_{DS(ON)}$ of the MOSFET is governed by its allowable power dissipation. For applications that may operate the LTC1622 in dropout, i.e., 100% duty cycle, at its worst case the required $R_{DS(ON)}$ is given by:

$$R_{DS(ON)DC=100\%} = \frac{P_P}{(I_{OUT(MAX)})^2(1 + \delta p)}$$

where P_P is the allowable power dissipation and δp is the temperature dependency of $R_{DS(ON)}$. $(1 + \delta p)$ is generally given for a MOSFET in the form of a normalized $R_{DS(ON)}$ vs temperature curve, but $\delta p = 0.005/^\circ C$ can be used as an approximation for low voltage MOSFETs.

In applications where the maximum duty cycle is less than 100% and the LTC1622 is in continuous mode, the $R_{DS(ON)}$ is governed by:

$$R_{DS(ON)} \cong \frac{P_P}{(DC)I_{OUT}^2(1 + \delta p)}$$

where DC is the maximum operating duty cycle of the LTC1622.

Output Diode Selection

The catch diode carries load current during the off-time. The average diode current is therefore dependent on the P-channel switch duty cycle. At high input voltages the diode conducts most of the time. As V_{IN} approaches V_{OUT} the diode conducts only a small fraction of the time. The most stressful condition for the diode is when the output is short-circuited. Under this condition the diode must safely handle I_{PEAK} at close to 100% duty cycle. Therefore, it is important to adequately specify the diode peak current and average power dissipation so as not to exceed the diode ratings.

Under normal load conditions, the average current conducted by the diode is:

$$I_D = \left(\frac{V_{IN} - V_{OUT}}{V_{IN} + V_D} \right) I_{OUT}$$

The allowable forward voltage drop in the diode is calculated from the maximum short-circuit current as:

$$V_F \approx \frac{P_D}{I_{SC(MAX)}}$$

where P_D is the allowable power dissipation and will be determined by efficiency and/or thermal requirements.

A fast switching diode must also be used to optimize efficiency. Schottky diodes are a good choice for low forward drop and fast switching times. Remember to keep lead length short and observe proper grounding (see Board Layout Checklist) to avoid ringing and increased dissipation.

APPLICATIONS INFORMATION

C_{IN} and C_{OUT} Selection

In continuous mode, the source current of the P-channel MOSFET is a square wave of duty cycle $(V_{OUT} + V_D)/(V_{IN} + V_D)$. To prevent large voltage transients, a low ESR input capacitor sized for the maximum RMS current must be used. The maximum RMS capacitor current is given by:

$$C_{IN} \text{ Required } I_{RMS} \approx I_{MAX} \frac{[V_{OUT}(V_{IN} - V_{OUT})]^{1/2}}{V_{IN}}$$

This formula has a maximum at $V_{IN} = 2V_{OUT}$, where $I_{RMS} = I_{OUT}/2$. This simple worst-case condition is commonly used for design because even significant deviations do not offer much relief. Note that capacitor manufacturer's ripple current ratings are often based on 2000 hours of life. This makes it advisable to further derate the capacitor, or to choose a capacitor rated at a higher temperature than required. Several capacitors may be paralleled to meet the size or height requirements in the design. Due to the high operating frequency of the LTC1622, ceramic capacitors can also be used for C_{IN} . Always consult the manufacturer if there is any question.

The selection of C_{OUT} is driven by the required effective series resistance (ESR). Typically, once the ESR requirement is satisfied, the capacitance is adequate for filtering. The output ripple (ΔV_{OUT}) is approximated by:

$$\Delta V_{OUT} \approx I_{RIPPLE} \left(ESR + \frac{1}{4fC_{OUT}} \right)$$

where f is the operating frequency, C_{OUT} is the output capacitance and I_{RIPPLE} is the ripple current in the inductor. The output ripple is highest at maximum input voltage since ΔI_L increases with input voltage.

Manufacturers such as Nichicon, United Chemicon and Sanyo should be considered for high performance through-hole capacitors. The OS-CON semiconductor dielectric capacitor available from Sanyo has the lowest ESR (size) product of any aluminum electrolytic at a somewhat higher price. Once the ESR requirement for C_{OUT} has been met, the RMS current rating generally far exceeds the $I_{RIPPLE(P-P)}$ requirement.

In surface mount applications, multiple capacitors may have to be paralleled to meet the ESR or RMS current handling requirements of the application. Aluminum electrolytic and dry tantalum capacitors are both available in surface mount configurations. In the case of tantalum, it is critical that the capacitors are surge tested for use in switching power supplies. An excellent choice is the AVX TPS, AVX TPSV and KEMET T510 series of surface mount tantalum, available in case heights ranging from 2mm to 4mm. Other capacitor types include Sanyo OS-CON, Nichicon PL series and Panasonic SP.

Low Supply Operation

Although the LTC1622 can function down to 2V, the maximum allowable output current is reduced when V_{IN} decreases below 3V. Figure 3 shows the amount of change as the supply is reduced down to 2V. Also shown in Figure 3 is the effect of V_{IN} on V_{REF} as V_{IN} goes below 2.3V.

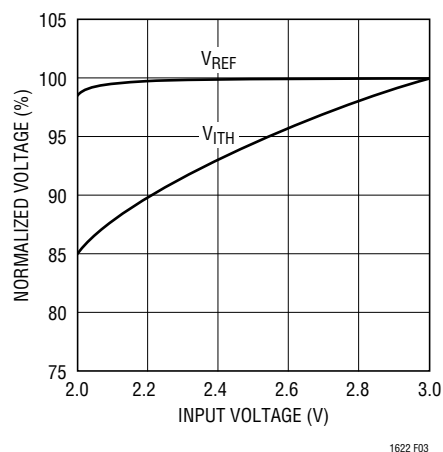

Figure 3. Line Regulation of V_{REF} and V_{ITH}

Setting Output Voltage

The LTC1622 develops a 0.8V reference voltage between the feedback (Pin 3) terminal and ground (see Figure 4). By selecting resistor R1, a constant current is caused to flow through R1 and R2 to set the overall output voltage. The regulated output voltage is determined by:

$$V_{OUT} = 0.8 \left(1 + \frac{R2}{R1} \right)$$

APPLICATIONS INFORMATION

For most applications, a 30k resistor is suggested for R1. To prevent stray pickup, a 100pF capacitor is suggested across R1 located close to LTC1622.

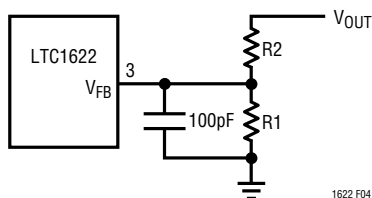

Figure 4. Setting Output Voltage

Efficiency Considerations

The efficiency of a switching regulator is equal to the output power divided by the input power times 100%. It is often useful to analyze individual losses to determine what is limiting the efficiency and which change would produce the most improvement. Efficiency can be expressed as:

$$\text{Efficiency} = 100\% - (\eta_1 + \eta_2 + \eta_3 + \dots)$$

where η_1 , η_2 , etc. are the individual losses as a percentage of input power.

Although all dissipative elements in the circuit produce losses, four main sources usually account for most of the losses in LTC1622 circuits: 1) LTC1622 DC bias current, 2) MOSFET gate charge current, 3) I^2R losses and 4) voltage drop of the output diode.

1. The V_{IN} current is the DC supply current, given in the electrical characteristics, that excludes MOSFET driver and control currents. V_{IN} current results in a small loss which increases with V_{IN} .
2. MOSFET gate charge current results from switching the gate capacitance of the power MOSFET. Each time a MOSFET gate is switched from low to high to low again, a packet of charge dQ moves from V_{IN} to ground. The resulting dQ/dt is a current out of V_{IN} which is typically much larger than the DC supply current. In continuous mode, $I_{GATECHG} = f(Qp)$.
3. I^2R losses are predicted from the DC resistances of the MOSFET, inductor and current shunt. In continuous

mode the average output current flows through L but is “chopped” between the P-channel MOSFET in series with R_{SENSE} and the output diode. The MOSFET $R_{DS(ON)}$ plus R_{SENSE} multiplied by duty cycle can be summed with the resistances of L and R_{SENSE} to obtain I^2R losses.

4. The output diode is a major source of power loss at high currents and gets worse at high input voltages. The diode loss is calculated by multiplying the forward voltage times the diode duty cycle multiplied by the load current. For example, assuming a duty cycle of 50% with a Schottky diode forward voltage drop of 0.4V, the loss increases from 0.5% to 8% as the load current increases from 0.5A to 2A.
5. Transition losses apply to the external MOSFET and increase at higher operating frequencies and input voltages. Transition losses can be estimated from:

$$\text{Transition Loss} = 2(V_{IN})^2 I_{O(MAX)} C_{RSS}(f)$$

Other losses including C_{IN} and C_{OUT} ESR dissipative losses, and inductor core losses, generally account for less than 2% total additional loss.

Run/Soft Start Function

The RUN/SS pin is a dual purpose pin that provides the soft start function and a means to shut down the LTC1622. Soft start reduces input surge current from V_{IN} by gradually increasing the internal current limit. Power supply sequencing can also be accomplished using this pin.

An internal 0.75 μ A current source charges up an external capacitor C_{SS} . When the voltage on the RUN/SS reaches 0.7V the LTC1622 begins operating. As the voltage on RUN/SS continues to ramp from 0.7V to 1V, the internal current limit is also ramped at a proportional linear rate. The current limit begins near 0A (at $V_{RUN/SS} = 0.7V$) and ends at $0.1/R_{SENSE}$ ($V_{RUN/SS} \geq 1.8V$). The output current thus ramps up slowly, reducing the starting surge current required from the input power supply. If the RUN/SS has been pulled all the way to ground, there will be a delay before the current limit starts increasing and is given by:

APPLICATIONS INFORMATION

$$t_{\text{DELAY}} = \frac{1.13C_{\text{SS}}}{I_{\text{CHG}}}$$

Pulling the RUN/SS pin below 0.4V puts the LTC1622 into a low quiescent current shutdown ($I_Q < 15\mu\text{A}$).

Foldback Current Limiting

As described in the Output Diode Selection, the worst-case dissipation occurs with a short-circuited output when the diode conducts the current limit value almost continuously. To prevent excessive heating in the diode, foldback current limiting can be added to reduce the current in proportion to the severity of the fault.

Foldback current limiting is implemented by adding diode D_{FB} between the output and the I_{TH} pin as shown in Figure 5. In a hard short ($V_{\text{OUT}} = 0\text{V}$), the current will be reduced to approximately 50% of the maximum output current.

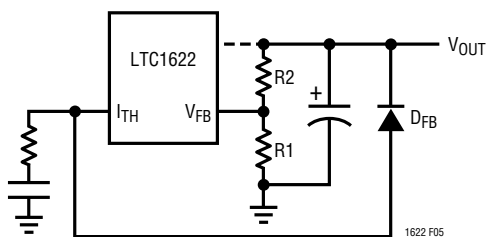

Figure 5. Foldback Current Limiting

Design Example

Assume the LTC1622 is used in a single Lithium-Ion battery-powered cellular phone application. The V_{IN} will be operating from a maximum of 4.2V down to a minimum of 2.7V. Load current requirement is a maximum of 1.5A but most of the time it will be on standby mode, requiring only 2mA. Efficiency at both low and high load current is important. Output voltage is 2.5V.

In the above application, Burst Mode operation is enabled by connecting Pin 5 to V_{IN} .

$$\text{Maximum Duty Cycle} = \frac{V_{\text{OUT}} + V_D}{V_{\text{IN(MIN)}} + V_D} = 93\%$$

From Figure 2, SF = 57%.

Use the curve of Figure 2 since the operating frequency is the free running frequency of the LTC1622.

$$R_{\text{SENSE}} = \frac{\text{SF}}{(15)(I_{\text{OUT}})(100)} = \frac{0.57}{(15)(1.5)} = 0.0253\Omega$$

In the application, a 0.025 Ω resistor is used. For the inductor, the required value is:

$$L_{\text{MIN}} = \frac{4.2 - 2.5}{550\text{kHz} \left(\frac{0.036}{0.025} \right)} \left(\frac{2.5 + 0.3}{4.2 + 0.3} \right) = 1.33\mu\text{H}$$

In the application, a 3.9 μH inductor is used to reduce ripple current.

For the selection of the external MOSFET, the $R_{\text{DS(ON)}}$ must be guaranteed at 2.5V since the LTC1622 has to work down to 2.7V. Let's assume that the MOSFET dissipation is to be limited to $P_P = 250\text{mW}$ and its thermal resistance is 50 $^{\circ}\text{C}/\text{W}$. Hence the junction temperature at $T_A = 25^{\circ}\text{C}$ will be 37.5 $^{\circ}\text{C}$ and $\delta p = 0.005 (37.5 - 25) = 0.0625$. The required $R_{\text{DS(ON)}}$ is then given by:

$$R_{\text{DS(ON)}} \cong \frac{P_P}{\text{DC}(I_{\text{OUT}})^2 (1 + \delta p)} = 0.11\Omega$$

The P-channel MOSFET requirement can be met by an Si6433DQ.

The requirement for the Schottky diode is the most stringent when $V_{\text{OUT}} = 0\text{V}$, i.e., short circuit. With a 0.025 Ω R_{SENSE} resistor, the short-circuit current through the Schottky is $0.1/0.025 = 4\text{A}$. An MBR340T3 Schottky diode is chosen. With 4A flowing through, the diode is rated with a forward voltage of 0.4V. Therefore, the worst-case power dissipated by the diode is 1.6W. The addition of D_{FB} (Figure 5) will reduce the diode dissipation to approximately 0.8W.

The input capacitor requires an RMS current rating of at least 0.75A at temperature, and C_{OUT} will require an ESR of 0.1 Ω for optimum efficiency.

APPLICATIONS INFORMATION

PC Board Layout Checklist

When laying out the printed circuit board, the following checklist should be used to ensure proper operation of the LTC1622. These items are illustrated graphically in the layout diagram in Figure 6. Check the following in your layout:

1. Is the Schottky diode closely connected between ground (Pin 6) and drain of the external MOSFET?
2. Does the (+) plate of C_{IN} connect to the sense resistor as closely as possible? This capacitor provides AC current to the MOSFET.
3. Is the input decoupling capacitor ($0.1\mu\text{F}$) connected closely between V_{IN} (Pin 8) and ground (Pin 6)?
4. Connect the end of R_{SENSE} as close to V_{IN} (Pin 8) as possible. The V_{IN} pin is the SENSE^+ of the current comparator.
5. Is the trace from the SENSE^- (Pin 1) to the Sense resistor kept short? Does the trace connect close to R_{SENSE} ?
6. Keep the switching node SW away from sensitive small signal nodes.
7. Does the V_{FB} pin connect directly to the feedback resistors? The resistive divider $R1$ and $R2$ must be connected between the (+) plate of C_{OUT} and signal ground. The 100pF capacitor should be as close as possible to the LTC1622.

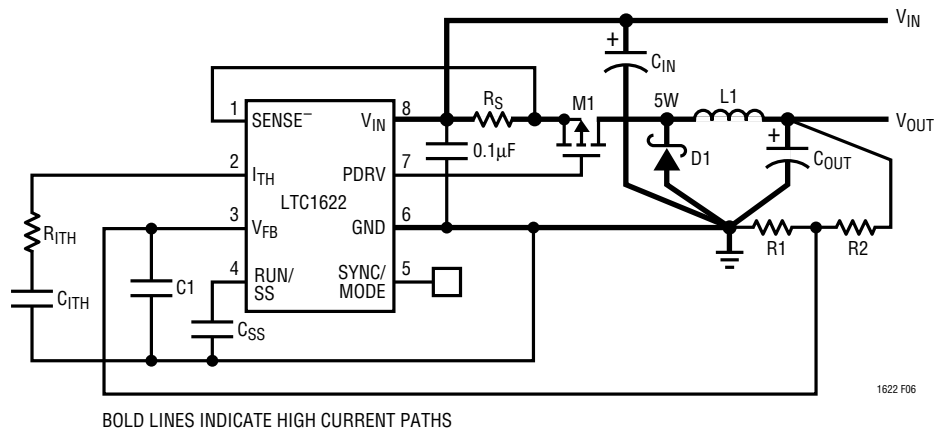
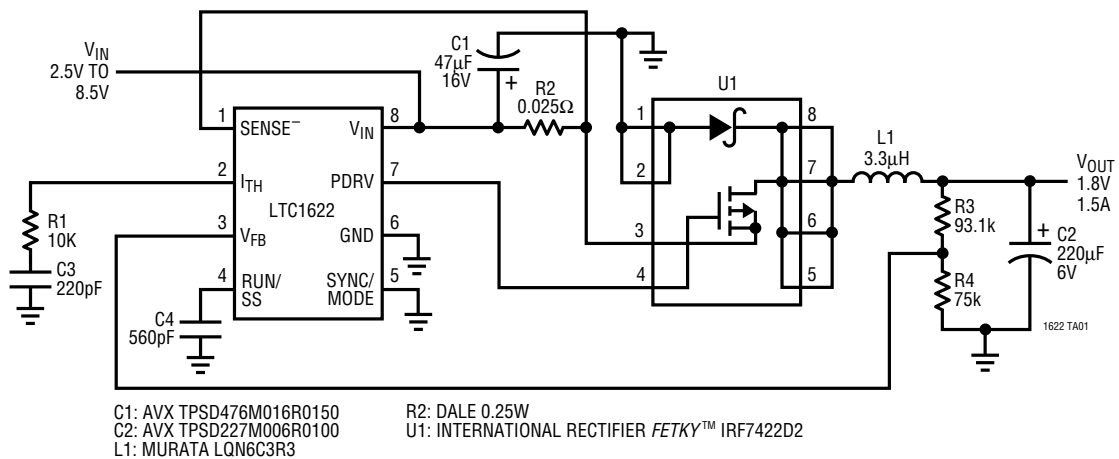

Figure 6. LTC1622 Layout Diagram (See PC Board Layout Checklist)

TYPICAL APPLICATIONS

LTC1622 1.8V/1.5A Regulator with Burst Mode Operation Disabled



LTC1622 2.5V/2A Regulator with Burst Mode Operation Enabled

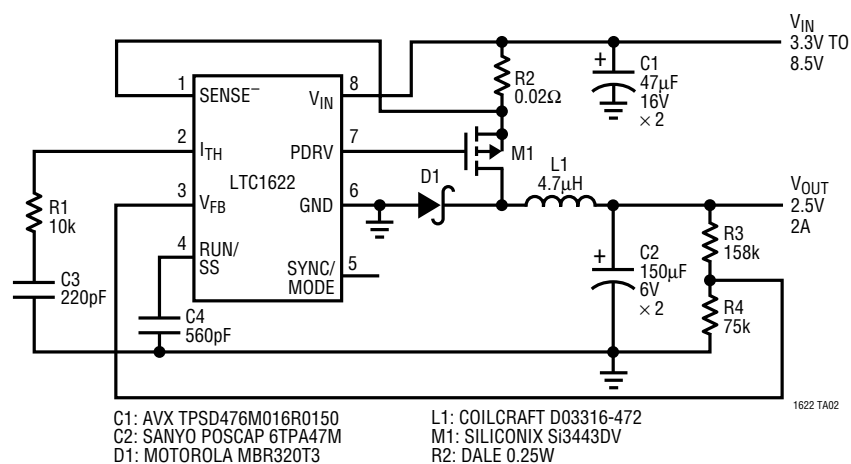

TYPICAL APPLICATIONS

LTC1622 2.5V/3A Regulator with External Clock

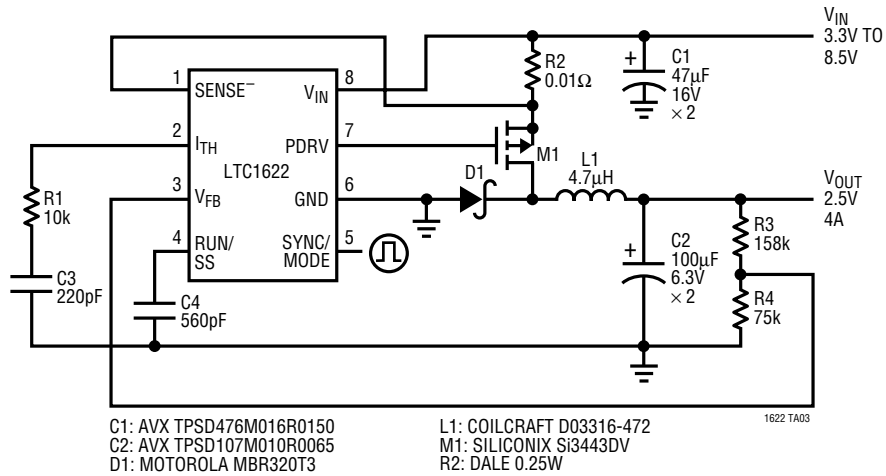

Zeta Converter with Foldback Current Circuit

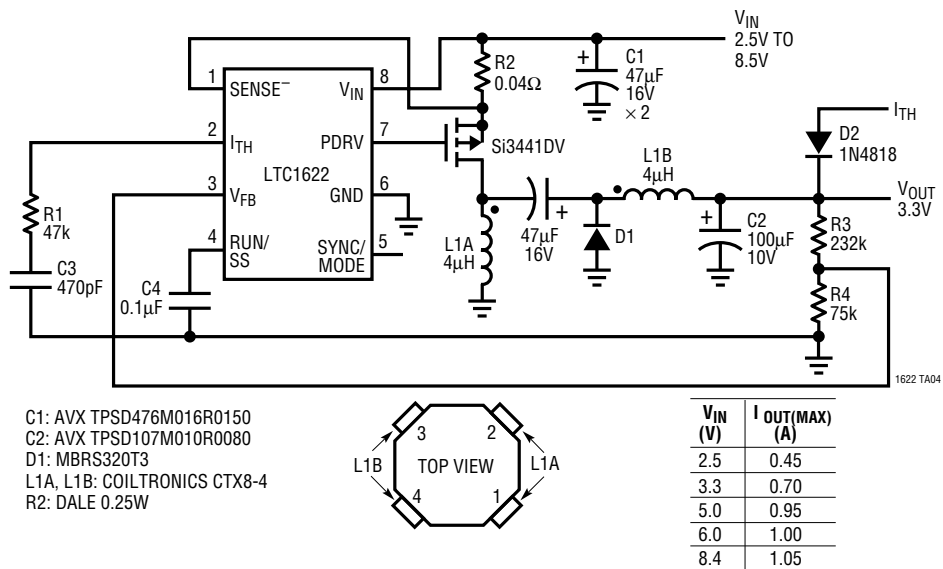

PACKAGE DESCRIPTION Dimensions in inches (millimeters) unless otherwise noted.

MS8 Package
8-Lead Plastic MSOP
 (LTC DWG # 05-08-1660)

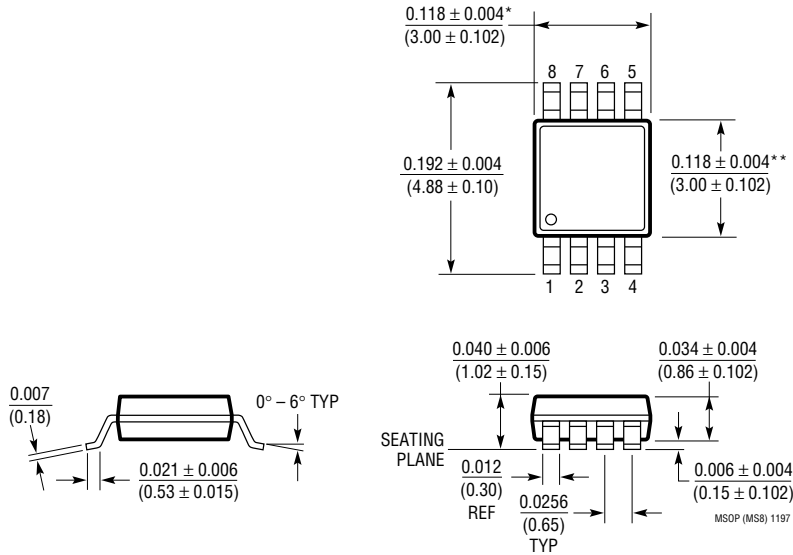

* DIMENSION DOES NOT INCLUDE MOLD FLASH, PROTRUSIONS OR GATE BURRS. MOLD FLASH, PROTRUSIONS OR GATE BURRS SHALL NOT EXCEED 0.006* (0.152mm) PER SIDE
 ** DIMENSION DOES NOT INCLUDE INTERLEAD FLASH OR PROTRUSIONS. INTERLEAD FLASH OR PROTRUSIONS SHALL NOT EXCEED 0.006* (0.152mm) PER SIDE

S8 Package
8-Lead Plastic Small Outline (Narrow 0.150)
 (LTC DWG # 05-08-1610)

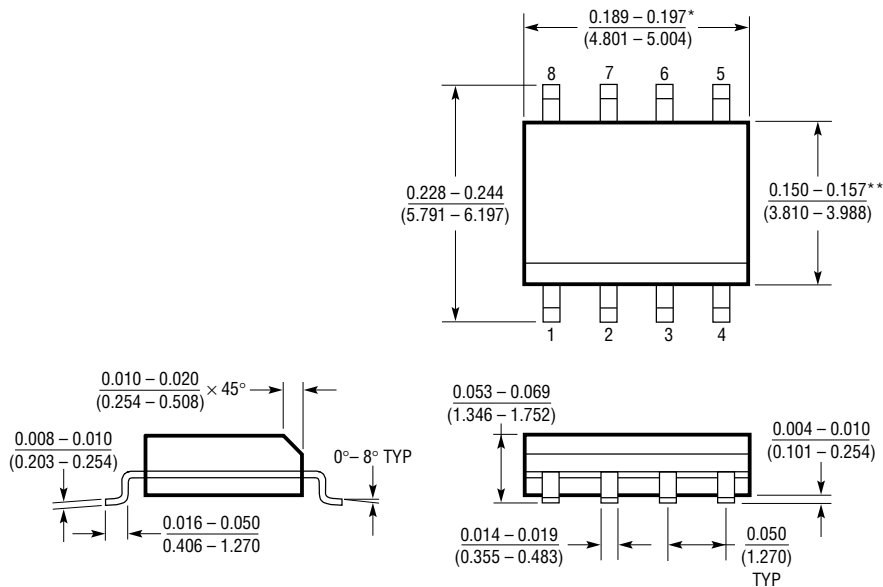

* DIMENSION DOES NOT INCLUDE MOLD FLASH. MOLD FLASH SHALL NOT EXCEED 0.006* (0.152mm) PER SIDE
 ** DIMENSION DOES NOT INCLUDE INTERLEAD FLASH. INTERLEAD FLASH SHALL NOT EXCEED 0.010* (0.254mm) PER SIDE

LTC1622

TYPICAL APPLICATION

Small Footprint 3.3V/1A Regulator

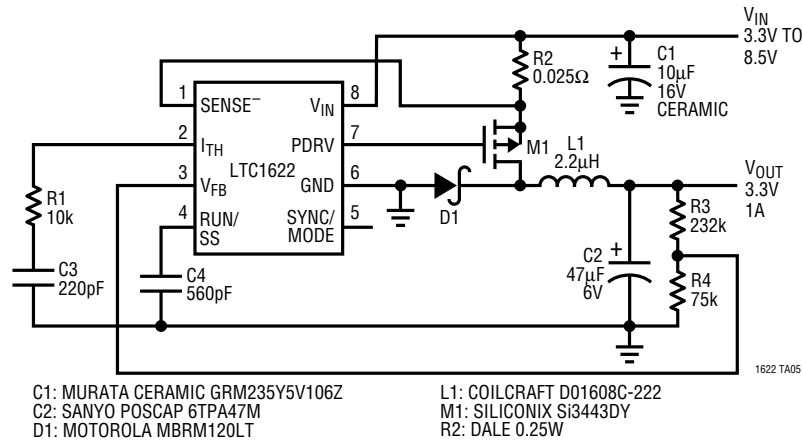

Efficiency vs Load Current

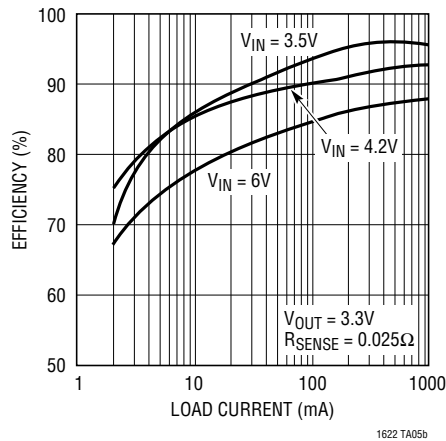

RELATED PARTS

PART NUMBER	DESCRIPTION	COMMENTS
LTC1147 Series	High Efficiency Step-Down Switching Regulator Controllers	100% DC, $3.5V \leq V_{IN} \leq 16V$
LT1375/LT1376	1.5A, 500kHz Step-Down Switching Regulators	High Frequency, Small Inductor, High Efficiency
LTC1435	Single, High Efficiency, Low Noise Synchronous Switching Controller	High Efficiency 5V to 3.3V Conversion at up to 15A
LTC1436/LTC1436-PLL	High Efficiency, Low Noise, Synchronous Step-Down Converters	24-Pin Narrow SSOP, $3.5V \leq V_{IN} \leq 36V$
LTC1438/LTC1439	Dual, Low Noise, Synchronous Step-Down Converters	Multiple Output Capability, $3.5V \leq V_{IN} \leq 36V$
LTC1624	High Efficiency SO-8 N-Channel Switching Regulator Controller	8-Pin N-Channel Drive, $3.5V \leq V_{IN} \leq 36V$
LTC1626	Low Voltage, High Efficiency Step-Down DC/DC Converter	Monolithic, Constant Off-Time, Low Voltage Range: 2.5V to 6V
LTC1627	Low Voltage, Monolithic Synchronous Step-Down Regulator	Low Supply Voltage Range: 2.65V to 8V, 0.5A