



# LTC1145/LTC1146

## Low Power Digital Isolator

### FEATURES

- UL Recognized  (LTC1145A, LTC1146A)  
File E151738 to UL1577
- **Low Input Current**  
LTC1145: 700 $\mu$ A  
LTC1146: 70 $\mu$ A
- Maximum Input Frequency  
LTC1145: 200kHz  
LTC1146: 20kHz
- TTL Level Output
- Noise Filter Prevents Glitches at the Output
- Output Can Be Synchronized to an External Clock

### APPLICATIONS

- Low Power Opto-Isolator Replacement
- Isolated Serial Data Interfaces
- Isolated Power MOSFET Drivers

### DESCRIPTION

The LTC1145A/LTC1146A provide 2500V<sub>RMS</sub> (1 minute) or 3000V<sub>RMS</sub> (1 second) of input to output isolation for TTL digital/CMOS signals. The LTC1145/LTC1146 are intended for less stringent applications and are rated for 500V<sub>RMS</sub>. Unlike opto-isolators, the input current is a mere 70 $\mu$ A for the LTC1146 which can handle frequencies up to 20kHz. The faster LTC1145 will handle frequencies up to 200kHz while only drawing 700 $\mu$ A.

The output signal is in phase with the input and swings between GND2 and V<sub>CC</sub> providing a TTL/CMOS compatible signal without any pull-up resistors. An on-chip noise filter helps prevent glitches and data errors at the output, and a pin is provided for synchronizing the output signal to an external system clock.

**EDN** IC Innovation of the Year Winner

### TYPICAL APPLICATION

Digital Isolation Interface  
Data Rate Up to 200kHz

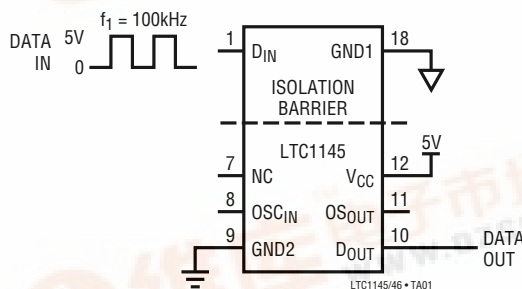

LTC1145 Typical Waveforms

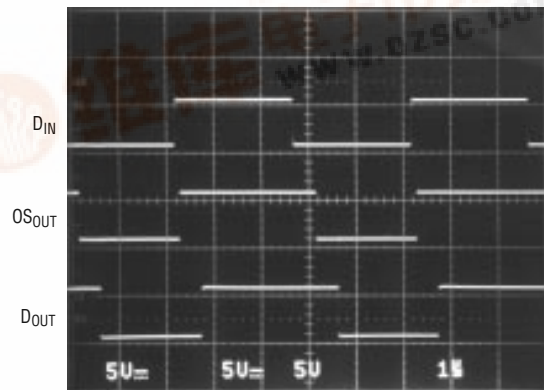

OS<sub>OUT</sub> AND D<sub>OUT</sub> LOADED WITH 15pF SCOPE PROBE

LTC1145/6 • TA02



# LTC1145/LTC1146

## ABSOLUTE MAXIMUM RATINGS

Supply Voltage .....	12V	Operating Temperature Range .....	0°C to 70°C
Input Voltage		Storage Temperature Range .....	-65°C to 150°C
$D_{IN}$ .....	11V to (GND1 - 0.3V)	Lead Temperature (Soldering, 10 sec) .....	300°C
$OSC_{IN}$ .....	( $V_{CC} + 0.3V$ ) to (GND2 - 0.3V)		
Output Voltage			
$OS_{OUT}$ , $D_{OUT}$ .....	( $V_{CC} + 0.3V$ ) to (GND2 - 0.3V)		

## PACKAGE/ORDER INFORMATION

<p>N PACKAGE 18-LEAD PLASTIC DIP <math>T_{JMAX} = 125^{\circ}C</math>, <math>\theta_{JA} = 110^{\circ}C/W</math></p>	<p>ORDER PART NUMBER</p> <p>LTC1145CN LTC1145ACN</p>	<p>N PACKAGE 18-LEAD PLASTIC DIP <math>T_{JMAX} = 125^{\circ}C</math>, <math>\theta_{JA} = 110^{\circ}C/W</math></p>	<p>ORDER PART NUMBER</p> <p>LTC1146CN LTC1146ACN</p>

Consult factory for Industrial and Military grade parts.

## ELECTRICAL CHARACTERISTICS $V_{CC} = 5V$ , $T_A = 25^{\circ}C$ unless otherwise noted.

SYMBOL	PARAMETER	CONDITIONS	MIN	TYP	MAX	UNITS
<b>LTC1145</b>						
$V_{OL}$	Output Low Voltage	$OS_{OUT}$ , $D_{OUT}$ at 4mA	●		0.4	V
$V_{OH}$	Output High Voltage	$OS_{OUT}$ , $D_{OUT}$ at 4mA	●	3.5		V
$V_{IL}$	External Frequency Input Low Voltage	$OSC_{IN}$	●		0.8	V
$V_{IH}$	External Frequency Input High Voltage	$OSC_{IN}$	●	2.4		V
$I_{IN}$	Input Current	$OSC_{IN}$ at 5V $D_{IN}$ at 3V $D_{IN}$ at 5V $D_{IN}$ at 10V	● ● ● ●		10.0 0.45 0.70 1.85	$\mu A$ mA mA mA
$I_{CC}$	Supply Current	$OSC_{IN} = 0V$	●	2	3.5	mA
$t_{PLH1}$	$D_{IN}$ to $OS_{OUT}$ , Low to High	$C_L = 15pF$	●	0.2	0.7	$\mu s$
$t_{PHL1}$	$D_{IN}$ to $OS_{OUT}$ , High to Low	$C_L = 15pF$	●	0.4	1.1	$\mu s$
$t_{PLH2}$	$D_{IN}$ to $D_{OUT}$ , Low to High	$C_L = 15pF$	●	0.7	1.5	$\mu s$
$t_{PHL2}$	$D_{IN}$ to $D_{OUT}$ , High to Low	$C_L = 15pF$	●	1.1	2	$\mu s$
SR	Input Signal Slew Rate	$D_{IN}$		1		V/ $\mu s$
CMSR	Common-Mode Slew Rate (Note 1)	$D_{IN} = GND1$ Connected to $V_{CM}$			1000	V/ $\mu s$
$V_{INH}$	Input High Voltage	$D_{IN}$	●	3		V
$V_{INL}$	Input Low Voltage	$D_{IN}$	●		0.8	V
$V_{ISO}$	Isolation Voltage, LTC1145A	1 Minute (Note 2) 1 Second		2500 3000		$V_{RMS}$ $V_{RMS}$

## ELECTRICAL CHARACTERISTICS $V_{CC} = 5V$ , $T_A = 25^\circ C$ unless otherwise noted.

SYMBOL	PARAMETER	CONDITIONS	MIN	TYP	MAX	UNITS
<b>LTC1146</b>						
$V_{OL}$	Output Low Voltage	$OS_{OUT}$ , $D_{OUT}$ at 4mA	●		0.4	V
$V_{OH}$	Output High Voltage	$OS_{OUT}$ , $D_{OUT}$ at 4mA	●	3.5		V
$V_{IL}$	Input Low Voltage	$D_{IN}$	●		0.8	V
$V_{IH}$	Input High Voltage	$D_{IN}$	●	3		V
$I_{IN}$	Input Current	$D_{IN}$ at 3V	●	40	80	$\mu A$
		$D_{IN}$ at 5V	●	70	120	$\mu A$
		$D_{IN}$ at 10V	●	225	350	$\mu A$
$I_{CC}$	Supply Current	$V_{CC} = 5V$	●	1.8	3	mA
$t_{PLH1}$	$D_{IN}$ to $OS_{OUT}$ , Low to High	$C_L = 15pF$	●	0.5	1.5	$\mu s$
$t_{PHL1}$	$D_{IN}$ to $OS_{OUT}$ , High to Low	$C_L = 15pF$	●	6	11	$\mu s$
$t_{PLH2}$	$D_{IN}$ to $D_{OUT}$ , Low to High	$C_L = 15pF$ , $C_{EXT} = 50pF$	●	5	10	$\mu s$
$t_{PHL2}$	$D_{IN}$ to $D_{OUT}$ , High to Low	$C_L = 15pF$ , $C_{EXT} = 50pF$	●	10	18	$\mu s$
SR	Input Signal Slew Rate	$D_{IN}$		1		V/ $\mu s$
CMSR	Common-Mode Slew Rate (Note 1)	$D_{IN} = GND1$ Connected to $V_{CM}$			1000	V/ $\mu s$
$V_{ISO}$	Isolation Voltage, LTC1146A	1 Minute (Note 2)		2500		$V_{RMS}$
		1 Second		3000		$V_{RMS}$

The ● denotes specifications which apply over the operating temperature range.

**Note 1:** Pins 1 and 18 are connected together. Pins 7 through 12 are connected together.

**Note 2:** Value derived from 1 second test.

## TYPICAL PERFORMANCE CHARACTERISTICS

Output High Voltage ( $D_{OUT}$  and  $OS_{OUT}$ ) vs Temperature

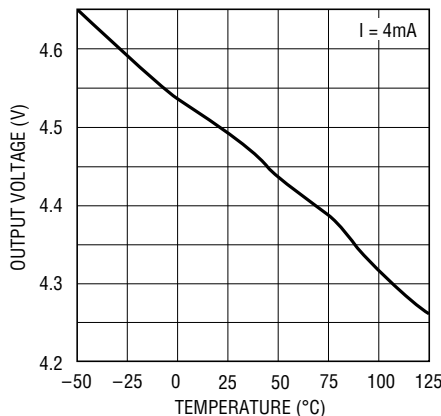

LTC1145/6 • TPC01

Output Low Voltage ( $D_{OUT}$  and  $OS_{OUT}$ ) vs Temperature

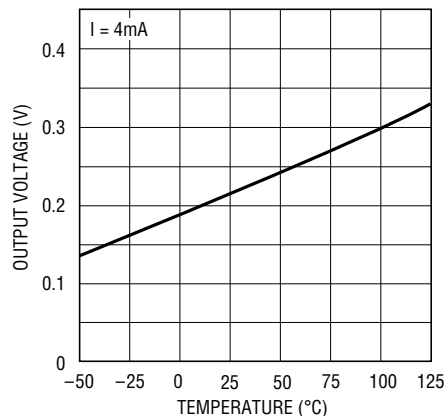

LTC1145/6 • TPC01

LTC1146 Input Current vs Input Voltage

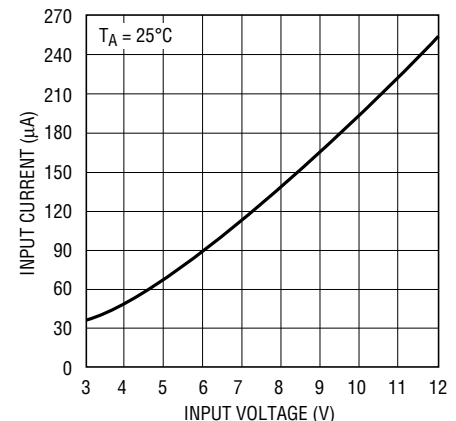

LTC1145/6 • TPC03

## TYPICAL PERFORMANCE CHARACTERISTICS

**LTC1145**  
Input Current vs Input Voltage

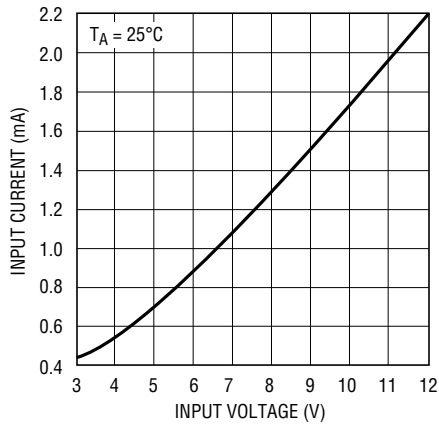

LTC1145/6 • TPC04

**LTC1145/LTC1146**  
Supply Current vs Temperature

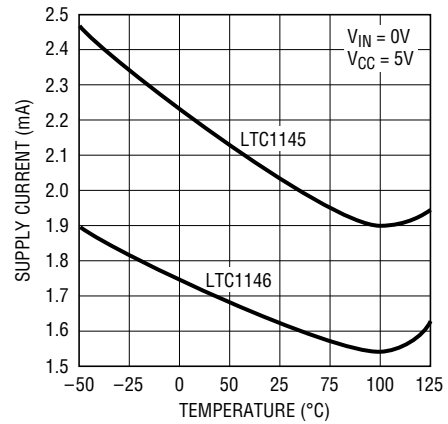

LTC1145/6 • TPC05

**LTC1146**  
Input Current vs Temperature

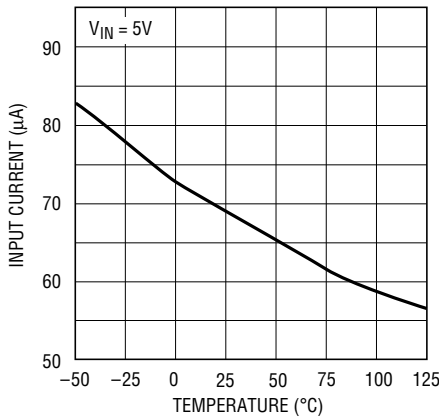

LTC1145/6 • TPC06

**LTC1145**  
Input Current vs Temperature

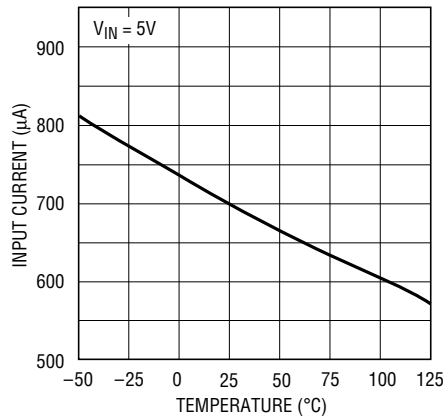

LTC1145/6 • TPC06

## PIN FUNCTIONS

**Pin 1 (D<sub>IN</sub>):** Data Input

**Pin 7 (NC):** Not Connected

**Pin 8 (LTC1145 OSC<sub>IN</sub>):** External Frequency Input. The signal on this pin overrides the internal oscillator frequency.

**Pin 8 (LTC1146 C<sub>EXT</sub>):** External Capacitor. Connecting a capacitor at this pin allows the internal oscillator frequency to be slowed down.

**Pin 9 (GND2):** The Ground Connection of the Receiver Die.

**Pin 10 (D<sub>OUT</sub>):** Data Output. The output signal has gone through the internal filter. The output level is TTL compatible.

**Pin 11 (OS<sub>OUT</sub>):** One-Shot Output. The output signal that does not go through the internal filter. The output level is TTL compatible.

**Pin 12 (V<sub>CC</sub>):** Positive Supply of the Receiver Die,  $4.5V < V_{CC} < 5.5V$ .

**Pin 18 (GND1):** The Ground Connection of the Driver Die.

## SWITCHING TIME WAVEFORMS

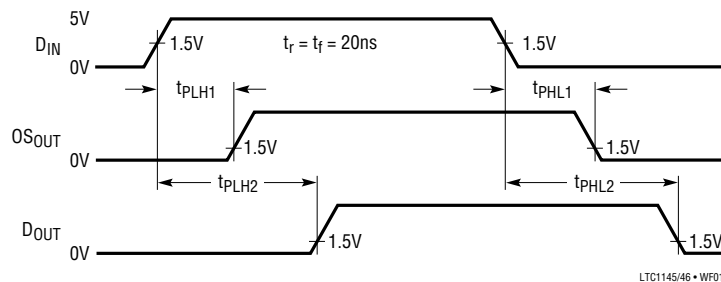

## FUNCTIONAL DIAGRAMS

LTC1145

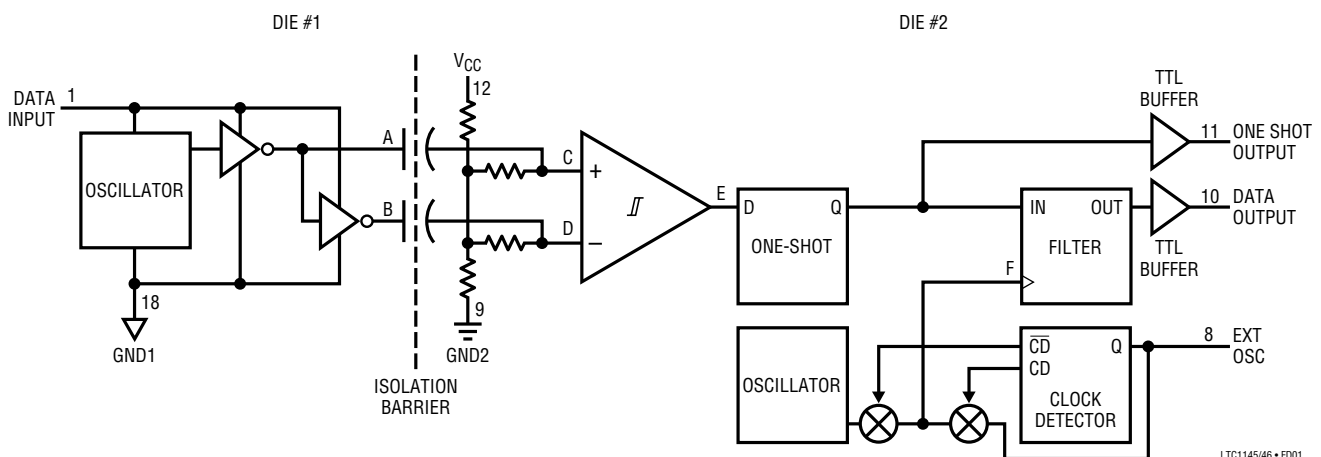

## FUNCTIONAL DIAGRAMS

LTC1146

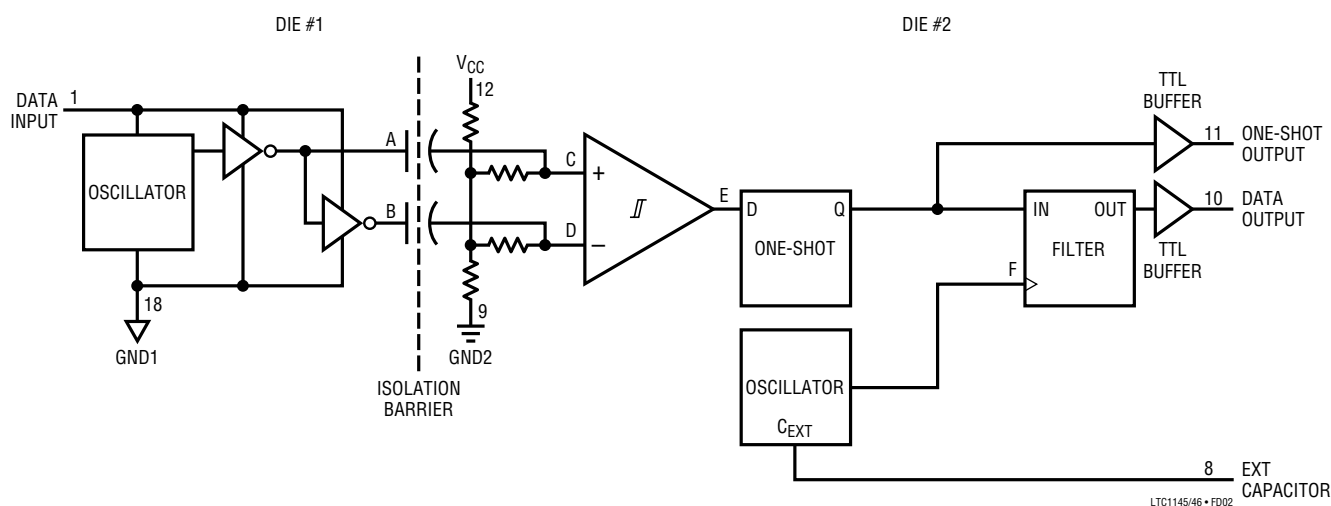

## OPERATION

## Basic Functionality

The LTC1145/LTC1146 consist of two separate die (see Functional Diagram) and two internal 1pF capacitors which provide isolation. Die #1 contains a low power oscillator and two low power drivers. The supply current for the oscillator and drivers comes from the digital input.

When the digital input exceeds 3V, the oscillator turns on and provides a 4MHz square wave to the drivers (400kHz for the LTC1146). The drivers pass the signal through the isolation capacitors and form a differential signal at the input to the comparator (points C and D) on die #2. As soon as the comparator output changes state in either direction, the one-shot output (OS) goes high. The time constant of the one-shot is set to 2 times the oscillation period, so the one-shot output will stay high as long as the oscillation continues. When the digital input goes low, the

oscillator on die #1 turns off and the one-shot output resets low.

To increase the noise immunity of the system, a filter is added to die #2. The filter is basically a binary counter clocked by either an internal free running oscillator or external oscillator. A clock detector circuit disconnects the internal oscillator from the filter and connects the external oscillator after detecting three pulses on the OSC<sub>IN</sub> pin. The frequency of the internal free running oscillator on die #2 is designed to match the frequency of the gated oscillator on die #1, but the two oscillators are not synchronized. For the digital output (D<sub>OUT</sub>) to go high, the filter must count four consecutive clock cycles with the one-shot output remaining high. For the digital output to go low, the filter must count four consecutive clock cycles with the one-shot output remaining low.

## OPERATION

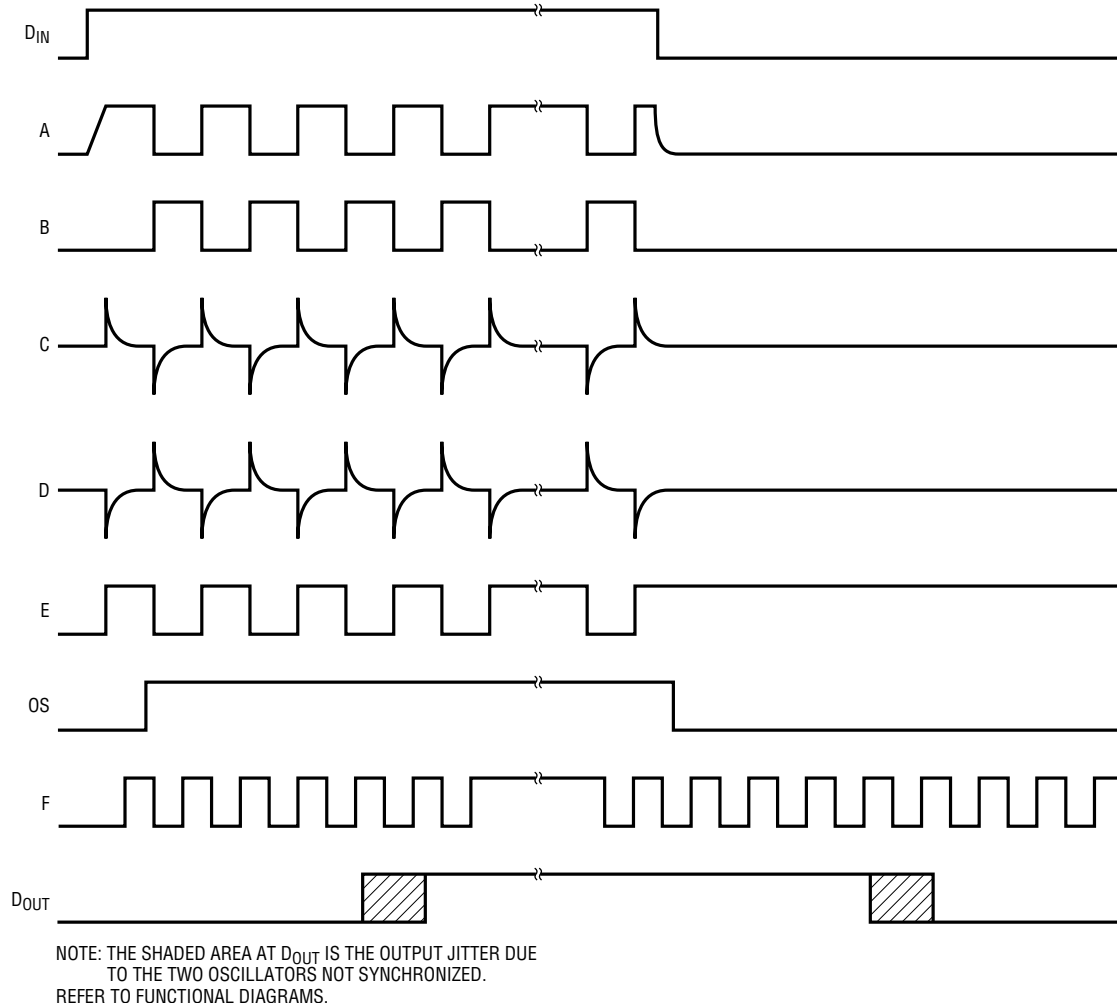

Figure 1. Block Diagram Waveforms

### Noise and Glitch Immunity

As an example, assume that the digital input is low and the oscillator on die #1 is off. There is a very large fast rising common-mode signal at the ground and input pins to die #1 with respect to the ground of die #2.

Any mismatch in the internal capacitors will convert the common-mode signal into a differential glitch at the inputs to the comparator. The output of the comparator will toggle and the output of the one-shot will go high. However, the filter will only count one clock cycle before the output of the one-shot resets, so the digital output will remain low. The filter works as long as the period of the common-mode signal is greater than the one-shot period.

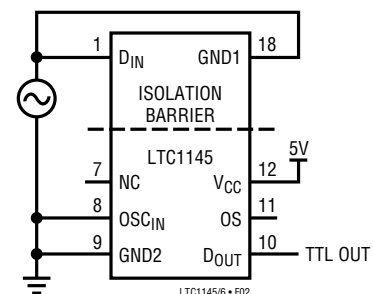

Figure 2. Common-Mode Rejection Test Circuit

# LTC1145/LTC1146

## OPERATION

### Internal Capacitors

A special lead frame has been designed for the LTC1145/LTC1146 which includes two die paddles and the isolation capacitors. Each capacitor is formed by three parallel metal fingers spaced about 20 mils apart. The capacitors' metal fingers and bonding posts replace the 5 center pins on each side of the 18-pin package. The dielectric for the

capacitors is the plastic package moulding compound. The material has a high dielectric constant and a high breakdown voltage. Typically the capacitance between the input and output is in the order of 1pF. This provides sufficient isolation in even the most critical of applications and is suitable for handling high voltage with high  $\Delta V/\Delta t$ .

## TYPICAL APPLICATIONS

### Isolated RS232 Driver/Receiver

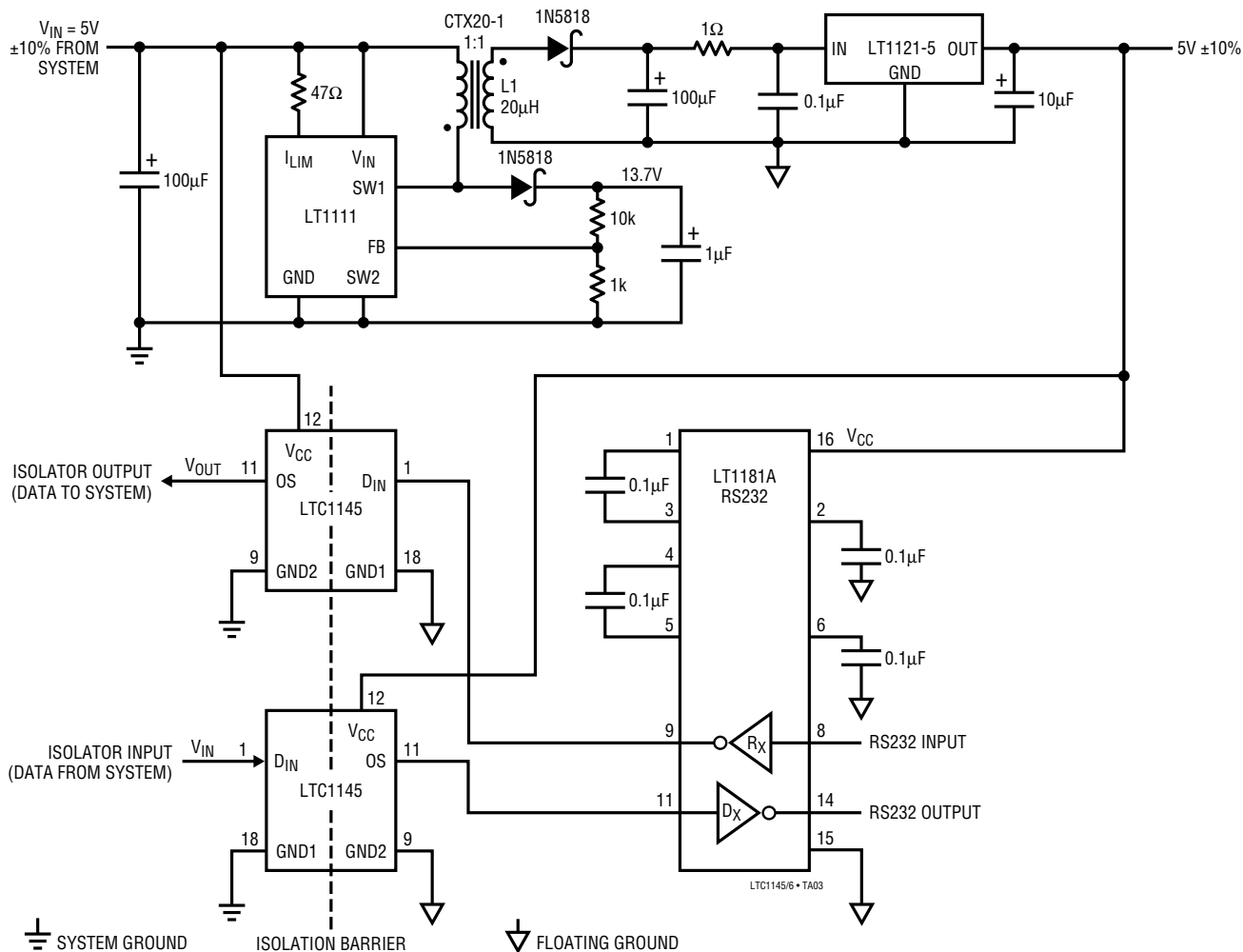

# TYPICAL APPLICATIONS

## 300V Isolated High-Side Driver

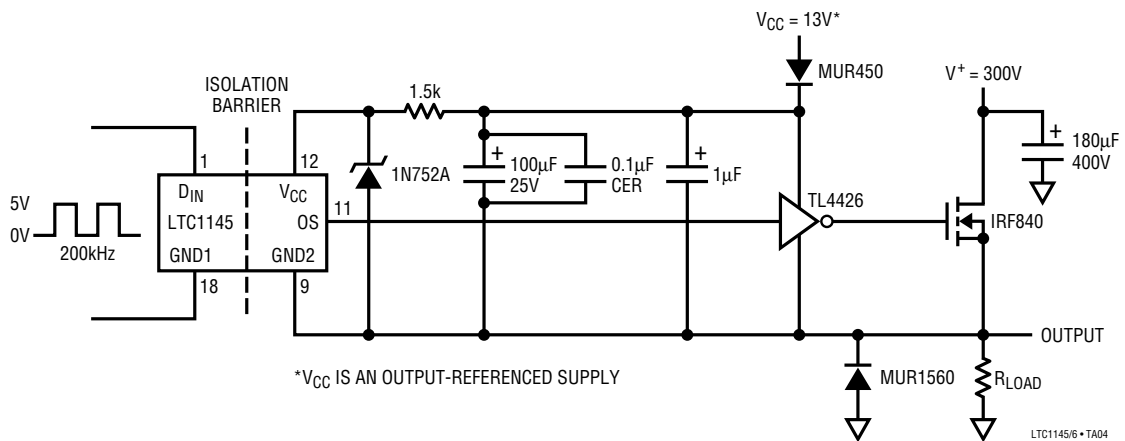

## Isolated Battery Power Temperature-to-Frequency Converter

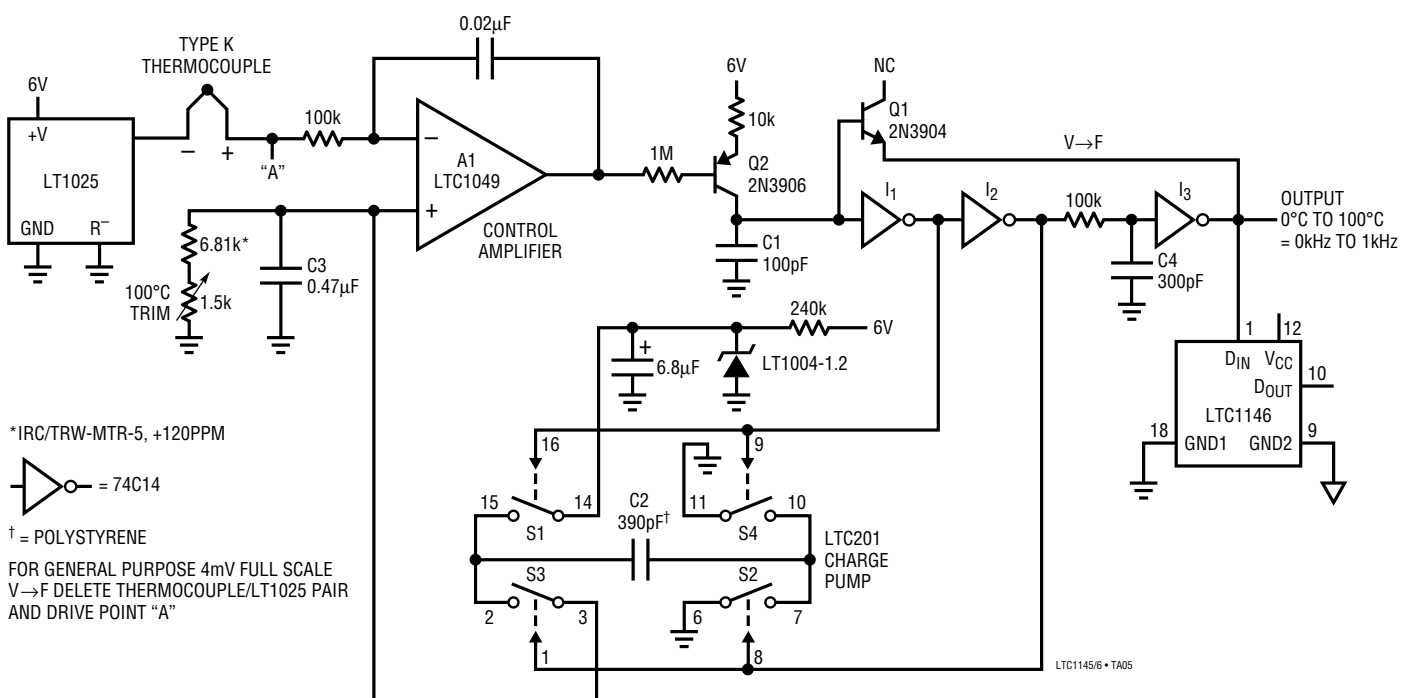





**PACKAGE DESCRIPTION** Dimensions in inches (millimeters) unless otherwise noted.

**N Package  
18-Lead Plastic DIP**

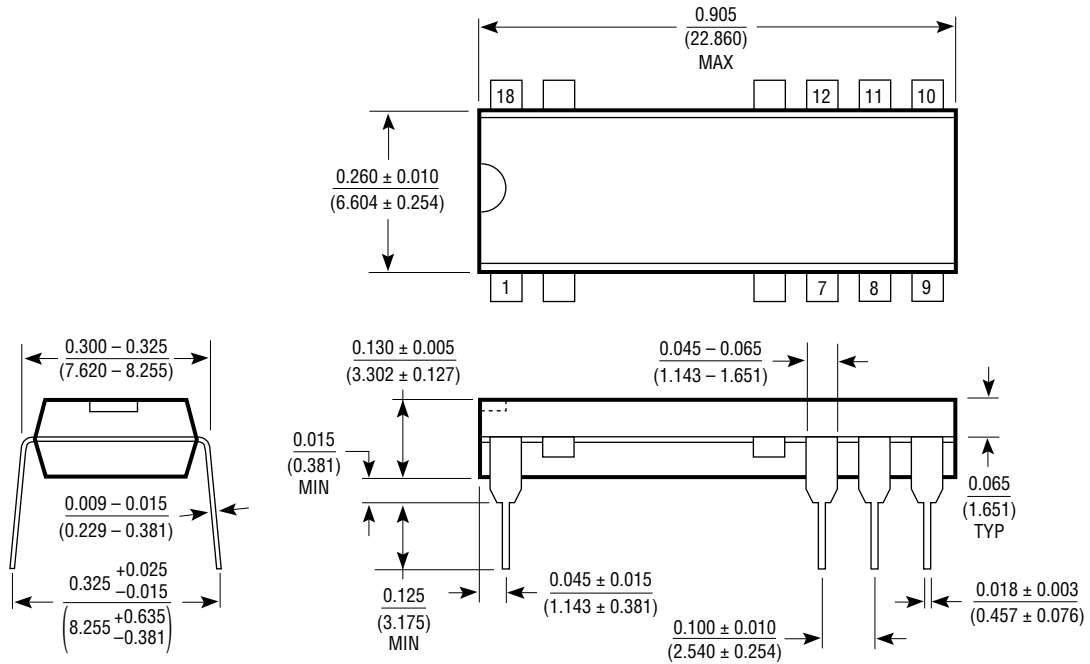

N18 0893