



500kHz Micropower DC/DC Converter for Flash Memory

May 1995

FEATURES

- 60mA Output Current at 12V from 3V or 5V Supply
- Shutdown to 9µA
- VPP VALID Comparator
- Up to 85% Efficiency
- Switching Frequency: 650kHz (Typical)
- Quiescent Current: 500µA
- Low V_{CESAT} Switch: 300mV at 0.5A (Typical)
- Soft Start Reduces Supply Current Transients
- Uses Low Value, Small Size, Surface Mount Inductors
- Available in 8-Lead SO Package

APPLICATIONS

- Flash Memory VPP Generators
- Type II and III PCMCIA Card DC/DC Converters
- 3V to 12V, 5V to 12V Converters
- Portable Computers and Instruments
- Cellular Telephones
- DC/DC Converter Module Replacements

DESCRIPTION

The LT[®]1309 is a 500kHz micropower DC/DC converter for Flash Memory. The regulator features Burst Mode[™] operation with a 0.5A, 300mV switch, enabling 85% efficiency at the fixed 12V output. High frequency operation permits the use of small value, and therefore small size, surface mount inductors and capacitors. The LT1309 comes in an 8-lead SO package allowing extremely compact PC board layouts. These features make the device attractive for PCMCIA cards, cellular phones and other applications where PC board space is limited.

Quiescent current is 650µA decreasing to 9µA when the part shuts down. The device includes a Soft Start feature which limits supply current transients during turn-on.

The LT1309 contains a VPP VALID comparator with a logic output that goes low when the output voltage is ready to program 12V Flash Memory. This comparator simplifies the interface to external control logic.

LT, LTC and LT are registered trademarks of Linear Technology Corporation. Burst Mode is a trademark of Linear Technology Corporation.

TYPICAL APPLICATION

12V, 60mA Flash Memory Programming Supply

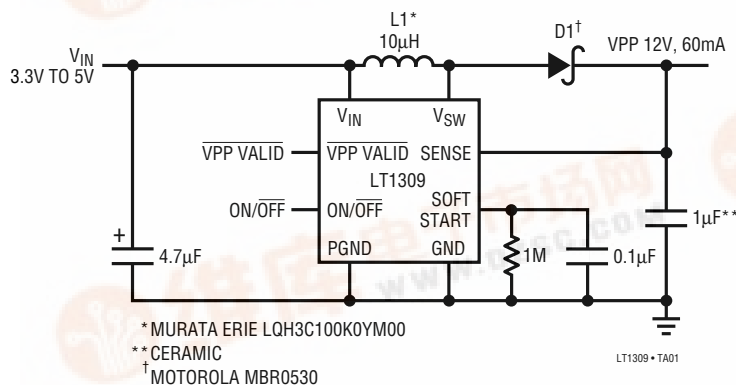

* MURATA ERIE LQH3C100K0YM00
** CERAMIC
† MOTOROLA MBR0530

12V Output Efficiency

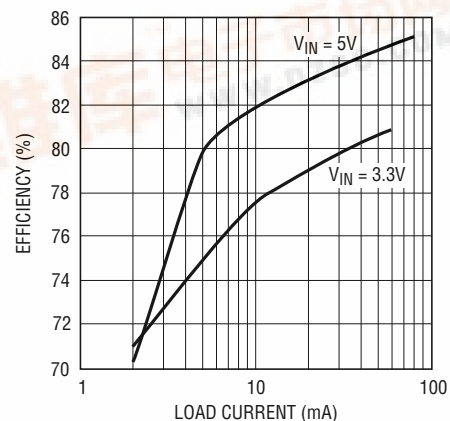

LT1309-TA02



LT1309

ABSOLUTE MAXIMUM RATINGS

V_{CC} Voltage	7V
V_{SW} Voltage	20V
V_{SENSE} Voltage	20V
$V_{ON/OFF}$ Voltage	7V
V_{SEL} Voltage	7V
I_{LIM} Voltage	7V
Maximum Power Dissipation	500mW
Operating Temperature Range	0°C to 70°C
Storage Temperature Range	-65°C to 150°C
Lead Temperature (Soldering, 10 sec)	300°C

PACKAGE/ORDER INFORMATION

<p>TOP VIEW</p> <p>SOFT START 1, VCC 2, PGND 3, VSW 4, 8 ON/OFF, 7 SENSE, 6 VPP VALID, 5 GND</p> <p>S8 PACKAGE 8-LEAD PLASTIC SO</p> <p>$T_{JMAX} = 150^{\circ}C, \theta_{JA} = 150^{\circ}C/W$</p>	ORDER PART NUMBER
	LT1309CS8
	S8 PART MARKING
	1309

Consult factory for Industrial and Military grade parts.

ELECTRICAL CHARACTERISTICS $T_A = 25^{\circ}C, V_{CC} = 5V, V_{ON/OFF} = 3V$, unless otherwise noted.

SYMBOL	PARAMETER	CONDITIONS	MIN	TYP	MAX	UNITS
I_Q	Quiescent Current	$V_{SENSE} = 12V$		650	900	μA
	Quiescent Current, Shutdown	$V_{ON/OFF} = 0.2V$		9	15	μA
	Input Voltage Range		2		6	V
	Output Sense Voltage		● 11.5	12	12.6	V
	Output Referred Comparator Hysteresis			35		mV
f_{OSC}	Oscillator Frequency	Current Limit Not Asserted	400	500	700	kHz
DC	Maximum Duty Cycle		● 80	85	92	%
t_{ON}	Switch On Time			1.7		μs
	Reference Line Regulation	$2V < V_{IN} < 6V$		0.06	0.15	%/V
V_{CESAT}	Switch Saturation Voltage	$I_{SW} = 0.5A$		230	350	mV
	Switch Leakage Current	$V_{SW} = 12V$, Switch Off		0.1	10	μA
	Switch Current Limit	$V_{IN} = 5V$, Soft Start Floating $V_{IN} = 3V$, Soft Start Floating	450 500	600 650	900 950	mA mA
	Soft Start Current	Soft Start Grounded		80	120	μA
	ON/OFF Input Voltage Low				0.8	V
	ON/OFF Input Voltage High		1.6			V
	ON/OFF Bias Current	$V_{ON/OFF} = 5V$ $V_{ON/OFF} = 3V$ $V_{ON/OFF} = 0V$		16.0 8.0 0.1	24.0 14.0 1.0	μA μA μA
	Sense Pin Input Current	$V_{ON/OFF} = 0.2V$		50.0 0.1	90 1	μA μA
	VPP VALID Threshold	V_{SENSE} Rising (High to Low Transition)	● 11.4		12	V
	VPP VALID Output Voltage Low	$I_{SINK} = 100\mu A$		0.13	0.3	V
	VPP VALID Output Voltage High	$I_{SOURCE} = 2.5\mu A$	4	4.5		V

The ● denotes specifications which apply over the full operating temperature range.

TYPICAL PERFORMANCE CHARACTERISTICS

Sense Voltage

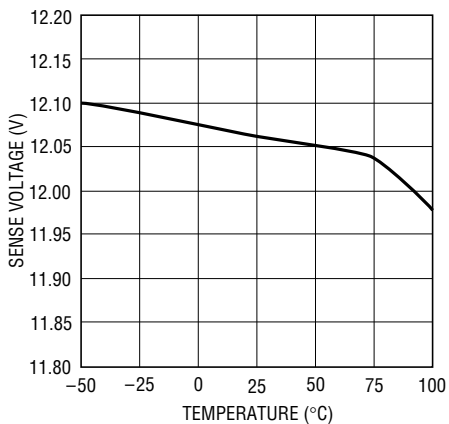

LT1309 • TPC01

Supply Current

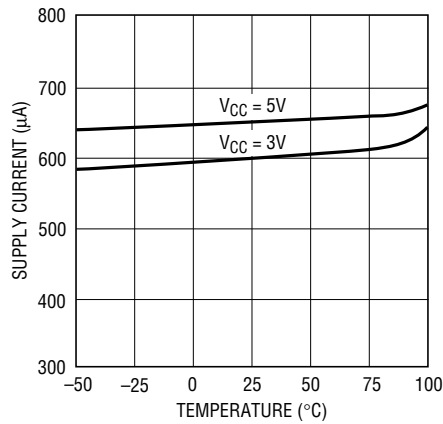

LT1309 • TPC02

Supply Current in Shutdown

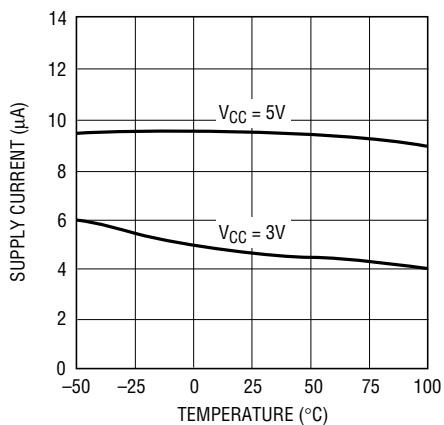

LT1309 • TPC03

Maximum Duty Cycle

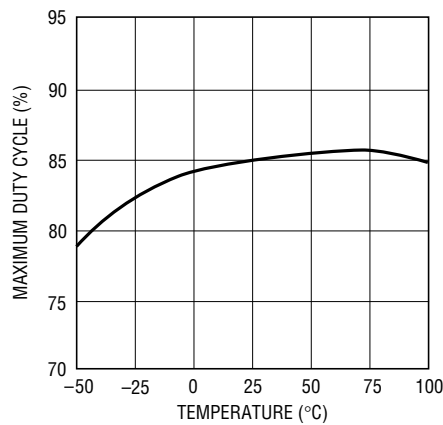

LT1309 • TPC04

Start-Up Waveforms, I_{LOAD} = 1mA

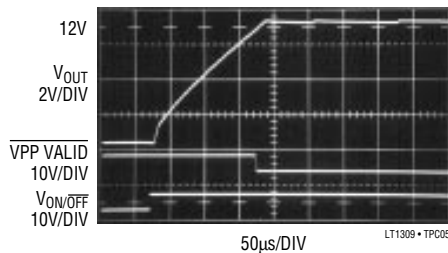

Start-Up Waveforms, I_{LOAD} = 10mA

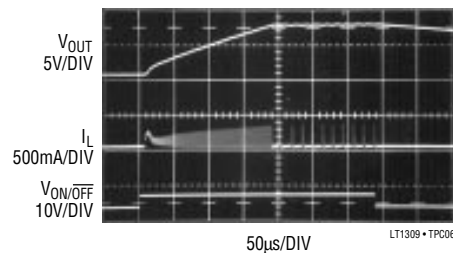

Load Transient Response, C_{OUT} = 1µF

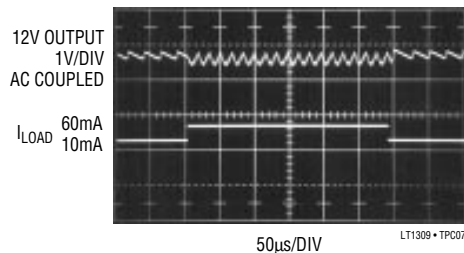

PIN FUNCTIONS

SOFT START (Pin 1): A 0.1 μ F/1M Ω parallel RC from this pin to GND provides a Soft Start function upon device turn-on. Initially about 80 μ A will flow from the pin into the capacitor. When the voltage at the pin reaches approximately 0.4V, current ceases flowing out of the pin.

V_{CC} (Pin 2): Input Supply. Both pins should be tied together. At least 1 μ F input bypass capacitance is required. More capacitance reduces ringing on the supply line.

PGND (Pin 3): Power Ground. Connect to ground plane.

V_{SW} (Pin 4): Collector of Power Switch. High dV/dt present on this pin. To minimize radiated noise keep layout short and direct.

GND (Pin 5): Signal Ground. Connect to ground plane.

VPP VALID (Pin 6): This pin provides a logic signal indicating that output voltage is greater than 11.4V. Active low with internal 200k pull-up resistor.

SENSE (Pin 7): Output Sense Pin. This pin connects to a resistive divider that sets the output voltage. In shutdown, the resistor string is disconnected and current into this pin reduces to < 1 μ A.

ON/OFF (Pin 8): Shutdown Control. When pulled below 1.5V, this pin disables the LT1309 and reduces supply current to 9 μ A. All circuitry is disabled in shutdown. The part is enabled when ON/OFF is greater than 1.5V.

BLOCK DIAGRAM

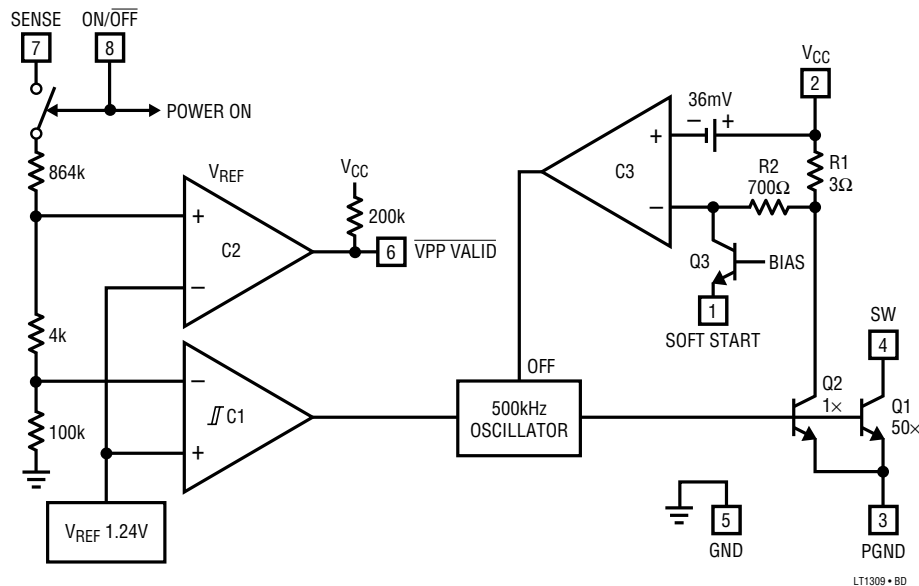

RELATED PARTS

PART NUMBER	DESCRIPTION	COMMENTS
LT1106	Micropower Step-Up DC/DC Converter, 12V at 60mA	Thin TSSOP Package for Type I PCMCIA Card
LT1109-12	Micropower Step-Up DC/DC Converter, 12V at 60mA	Flash Memory VPP Generator, Adjustable Also
LT1109A-12	Micropower Step-Up DC/DC Converter, 12V at 120mA	VPP Generator, Adjustable Also
LTC [®] 1262	Inductorless Flash Memory Programming Supply, 12V at 30mA	Switched Capacitor Converter, No Inductor
LT1303	Micropower High Efficiency DC/DC Converter with Low-Battery Detector	Adjustable and Fixed 5V, I _{OUT} up to 200mA