



12-Bit Serial Daisy-Chain CMOS D/A Converter

DAC8143

FEATURES

Fast, Flexible, Microprocessor Interfacing in Serially Controlled Systems

Buffered Digital Output Pin for Daisy-Chaining Multiple DACs

Minimizes Address-Decoding in Multiple DAC Systems—Three-Wire Interface for Any Number of DACs

One Data Line

One CLK Line

One Load Line

Improved Resistance to ESD

-40°C to +85°C for the Extended Industrial Temperature Range

APPLICATIONS

Multiple-Channel Data Acquisition Systems

Process Control and Industrial Automation

Test Equipment

Remote Microprocessor-Controlled Systems

GENERAL INFORMATION

The DAC8143 is a 12-bit serial-input daisy-chain CMOS D/A converter that features serial data input and buffered serial data output. It was designed for multiple serial DAC systems, where serially daisy-chaining one DAC after another is greatly simplified.

The DAC8143 also minimizes address decoding lines enabling simpler logic interfacing. It allows three-wire interface for any number of DACs: one data line, one CLK line and one load line.

Serial data in the input register (MSB first) is sequentially clocked out to the SRO pin as the new data word (MSB first) is simultaneously clocked in from the SRI pin. The strobe inputs are used to clock in/out data on the rising or falling (user selected) strobe edges (STB_1 , STB_2 , STB_3 , STB_4).

When the shift register's data has been updated, the new data word is transferred to the DAC register with use of LD_1 and LD_2 inputs.

Separate LOAD control inputs allow simultaneous output updating of multiple DACs. An asynchronous CLEAR input resets the DAC register without altering data in the input register.

Improved linearity and gain error performance permits reduced circuit parts count through the elimination of trimming components. Fast interface timing reduces timing design considerations while minimizing microprocessor wait states.

The DAC8143 is available in plastic packages that are compatible with autoinsertion equipment.

Plastic packaged devices come in the extended industrial temperature range of -40°C to +85°C.

FUNCTIONAL BLOCK DIAGRAM

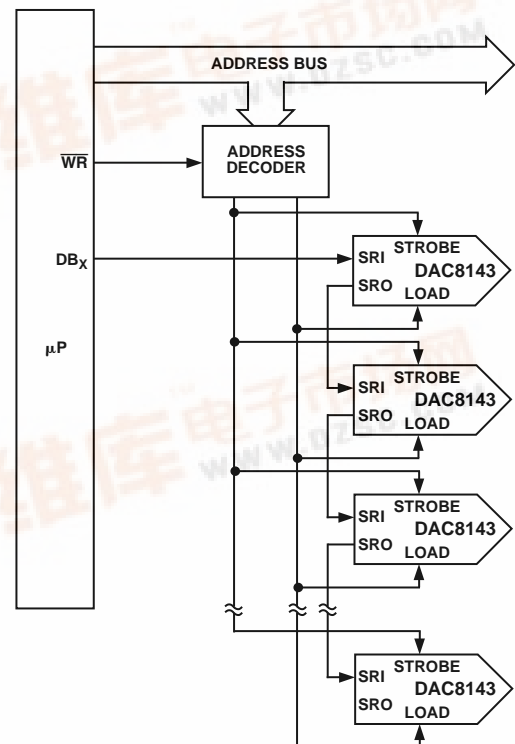
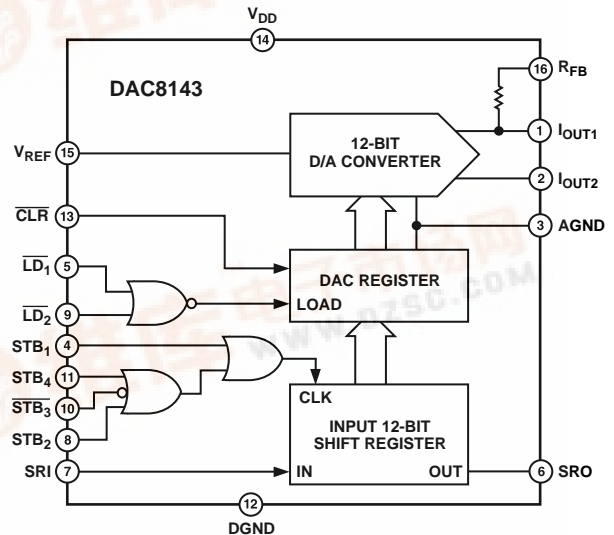

Figure 1. Multiple DAC8143s with Three-Wire Interface

REV. C

Information furnished by Analog Devices is believed to be accurate and reliable. However, no responsibility is assumed by Analog Devices for its use, nor for any infringements of patents or other rights of third parties which may result from its use. No license is granted by implication or otherwise under any patent or patent rights of Analog Devices.

DAC8143—SPECIFICATIONS

ELECTRICAL CHARACTERISTICS (@ $V_{DD} = +5\text{ V}$; $V_{REF} = +10\text{ V}$; $V_{OUT1} = V_{OUT2} = V_{AGND} = V_{DGND} = 0\text{ V}$; $T_A = \text{Full Temperature Range}$ specified under Absolute Maximum Ratings, unless otherwise noted.)

Parameter	Symbol	Conditions	Min	Typ	Max	Units	
STATIC ACCURACY							
Resolution	N		12			Bits	
Nonlinearity	INL				±1	LSB	
Differential Nonlinearity ¹	DNL				±1	LSB	
Gain Error ²	G_{FSE}				±2	LSB	
Gain Tempco ($\Delta\text{Gain}/\Delta\text{Temp}$) ³	TC_{GFS}				±5	ppm/°C	
Power Supply Rejection Ratio ($\Delta\text{Gain}/\Delta V_{DD}$)	PSRR	$\Delta V_{DD} = \pm 5\%$		±0.0006	±0.002	%/%	
Output Leakage Current ⁴	I_{LKG}	$T_A = +25^\circ\text{C}$ $T_A = \text{Full Temperature Range}$			±5 ±25	nA nA	
Zero Scale Error ^{5, 6}	I_{ZSE}	$T_A = +25^\circ\text{C}$ $T_A = \text{Full Temperature Range}$		±0.002	±0.03	LSB	
Input Resistance ⁷	R_{IN}	V_{REF} Pin	7	11	15	k Ω	
AC PERFORMANCE							
Output Current Settling Time ^{3, 8}	t_s			0.380	1	μs	
AC Feedthrough Error (V_{REF} to I_{OUT1}) ^{3, 9}	FT	$V_{REF} = 20\text{ V p-p @ } f = 10\text{ kHz}$, $T_A = +25^\circ\text{C}$			2.0	mV p-p	
Digital-to-Analog Glitch Energy ^{3, 10}	Q	$V_{REF} = 0\text{ V}$, I_{OUT} Load = 100 Ω , $C_{EXT} = 13\text{ pF}$			20	nVs	
Total Harmonic Distortion ³	THD	$V_{REF} = 6\text{ V rms @ } 1\text{ kHz}$ DAC Register Loaded with All 1s			-92	dB	
Output Noise Voltage Density ^{3, 11}	e_n	10 Hz to 100 kHz Between R_{FB} and I_{OUT}			13	nV/ $\sqrt{\text{Hz}}$	
DIGITAL INPUTS/OUTPUT							
Digital Input HIGH	V_{IH}		2.4			V	
Digital Input LOW	V_{IL}				0.8	V	
Input Leakage Current ¹²	I_{IN}	$V_{IN} = 0\text{ V to } +5\text{ V}$			±1	μA	
Input Capacitance	C_{IN}	$V_{IN} = 0\text{ V}$			8	pF	
Digital Output High	V_{OH}	$I_{OH} = -200\text{ }\mu\text{A}$	4			V	
Digital Output Low	V_{OL}	$I_{OL} = 1.6\text{ mA}$			0.4	V	
ANALOG OUTPUTS							
Output Capacitance ³	C_{OUT1}	Digital Inputs = All 1s			90	pF	
	C_{OUT2}	Digital Inputs = All 0s			90	pF	
Output Capacitance ³	C_{OUT1}	Digital Inputs = All 0s			60	pF	
	C_{OUT2}	Digital Inputs = All 1s			60	pF	
TIMING CHARACTERISTICS³							
Serial Input to Strobe Setup Times ($t_{STB} = 80\text{ ns}$)	t_{DS1}	STB ₁ Used as the Strobe	50			ns	
	t_{DS2}	STB ₂ Used as the Strobe	20			ns	
	t_{DS3}	STB ₃ Used as the Strobe	$T_A = +25^\circ\text{C}$	10			ns
			$T_A = \text{Full Temperature Range}$	20			ns
t_{DS4}	STB ₄ Used as the Strobe	$T_A = +25^\circ\text{C}$	20			ns	
		$T_A = \text{Full Temperature Range}$	40			ns	
t_{DH1}	STB ₁ Used as the Strobe	$T_A = +25^\circ\text{C}$	50			ns	
		$T_A = \text{Full Temperature Range}$	50			ns	
		$T_A = +25^\circ\text{C}$	50			ns	
t_{DH2}	STB ₂ Used as the Strobe	$T_A = +25^\circ\text{C}$	50			ns	
		$T_A = \text{Full Temperature Range}$	60			ns	
Serial Input to Strobe Hold Times ($t_{STB} = 80\text{ ns}$)	t_{DH3}	STB ₃ Used as the Strobe	80			ns	
	t_{DH4}	STB ₄ Used as the Strobe	80			ns	

ELECTRICAL CHARACTERISTICS (@ $V_{DD} = +5\text{ V}$; $V_{REF} = +10\text{ V}$; $V_{OUT1} = V_{OUT2} = V_{AGND} = V_{DGND} = 0\text{ V}$; $T_A = \text{Full Temperature Range}$ specified under Absolute Maximum Ratings, unless otherwise noted.)

Parameter	Symbol	Conditions	DAC8143			Units
			Min	Typ	Max	
STB to SRO Propagation Delay ¹³	t_{PD}	$T_A = +25^\circ\text{C}$ $T_A = \text{Full Temperature Range}$			220 300	ns ns
SRI Data Pulsewidth	t_{SRI}		100			ns
STB ₁ Pulsewidth ($\overline{STB_1} = 80\text{ ns}$) ¹⁴	t_{STB1}		80			ns
STB ₂ Pulsewidth ($\overline{STB_2} = 100\text{ ns}$) ¹⁴	t_{STB2}		80			ns
STB ₃ Pulsewidth ($\overline{STB_3} = 80\text{ ns}$) ¹⁴	t_{STB3}		80			ns
STB ₄ Pulsewidth ($\overline{STB_4} = 80\text{ ns}$) ¹⁴	t_{STB4}		80			ns
Load Pulsewidth	t_{LD1}, t_{LD2}	$T_A = +25^\circ\text{C}$ $T_A = \text{Full Temperature Range}$	140 180			ns ns
LSB Strobe into Input Register to Load DAC Register Time	t_{ASB}		0			ns
CLR Pulsewidth	t_{CLR}		80			ns
POWER SUPPLY						
Supply Voltage	V_{DD}		4.75	5	5.25	V
Supply Current	I_{DD}	All Digital Inputs = V_{IH} or V_{IL} All Digital Inputs = 0 V or V_{DD}			2 0.1	mA mA
Power Dissipation	P_D	Digital Inputs = 0 V or V_{DD} $5\text{ V} \times 0.1\text{ mA}$ Digital Inputs = V_{IH} or V_{IL} $5\text{ V} \times 2\text{ mA}$			0.5 10	mW mW

NOTES

- ¹All grades are monotonic to 12 bits over temperature.
 - ²Using internal feedback resistor.
 - ³Guaranteed by design and not tested.
 - ⁴Applies to I_{OUT1} ; all digital inputs = V_{IL} , $V_{REF} = +10\text{ V}$; specification also applies for I_{OUT2} when all digital inputs = V_{IH} .
 - ⁵ $V_{REF} = +10\text{ V}$, all digital inputs = 0 V.
 - ⁶Calculated from worst case R_{REF} : I_{ZSE} (in LSBs) = $(R_{REF} \times I_{LKG} \times 4096) / V_{REF}$.
 - ⁷Absolute temperature coefficient is less than +300 ppm/°C.
 - ⁸ I_{OUT} , Load = 100 Ω . $C_{EXT} = 13\text{ pF}$, digital input = 0 V to V_{DD} or V_{DD} to 0 V. Extrapolated to 1/2 LSB: $t_S = \text{propagation delay } (t_{PD}) + 9\tau$, where τ equals measured time constant of the final RC decay.
 - ⁹All digital inputs = 0 V.
 - ¹⁰ $V_{REF} = 0\text{ V}$, all digital inputs = 0 V to V_{DD} or V_{DD} to 0 V.
 - ¹¹Calculations from $e_n = \sqrt{4KTRB}$ where:
K = Boltzmann constant, J/KR = resistance Ω
T = resistor temperature, K B = bandwidth, Hz
 - ¹²Digital inputs are CMOS gates; I_{IN} typically 1 nA at +25°C.
 - ¹³Measured from active strobe edge (STB) to new data output at SRO; $C_L = 50\text{ pF}$.
 - ¹⁴Minimum low time pulsewidth for STB₁, STB₂, and STB₄, and minimum high time pulsewidth for STB₃.
- Specifications subject to change without notice.

DAC8143

ABSOLUTE MAXIMUM RATINGS

($T_A = +25^\circ\text{C}$, unless otherwise noted.)

V_{DD} to DGND	+17 V
V_{REF} to DGND	± 25 V
V_{RFB} to DGND	± 25 V
AGND to DGND	$V_{DD} + 0.3$ V
DGND to AGND	$V_{DD} + 0.3$ V
Digital Input Voltage Range	-0.3 V to V_{DD}
Output Voltage (Pin 1, Pin 2)	-0.3 V to V_{DD}
Operating Temperature Range	
FP/FS Versions	-40°C to +85°C
Junction Temperature	+150°C
Storage Temperature	-65°C to +150°C
Lead Temperature (Soldering, 60 sec)	+300°C

Package Type	θ_{JA}^*	θ_{JC}	Units
16-Lead Plastic DIP	76	33	$^\circ\text{C}/\text{W}$
16-Lead SOIC	92	27	$^\circ\text{C}/\text{W}$

* θ_{JA} is specified for worst case mounting conditions, i.e., θ_{JA} is specified for device in socket for P-DIP package; θ_{JA} is specified for device soldered to printed circuit board for SOIC package.

CAUTION

- Do not apply voltage higher than V_{DD} or less than DGND potential on any terminal except V_{REF} (Pin 15) and R_{FB} (Pin 16).
- The digital control inputs are Zener-protected; however, permanent damage may occur on unprotected units from high energy electrostatic fields. Keep units in conductive foam at all times until ready to use.
- Use proper antistatic handling procedures.
- Absolute Maximum Ratings apply to packaged devices. Stresses above those listed under Absolute Maximum Ratings may cause permanent damage to the device.

ORDERING GUIDE

Model	Nonlinearity	Gain Error	Temperature Range	Package Descriptions	Package Options
DAC8143FP	± 1 LSB	± 2 LSB	-40°C to +85°C	16-Lead Plastic DIP	N-16
DAC8143FS	± 1 LSB	± 2 LSB	-40°C to +85°C	16-Lead SOIC	R-16W

Die Size: 99 × 107 mil, 10,543 sq. mils.

CAUTION

ESD (electrostatic discharge) sensitive device. Electrostatic charges as high as 4000 V readily accumulate on the human body and test equipment and can discharge without detection. Although the DAC8143 features proprietary ESD protection circuitry, permanent damage may occur on devices subjected to high energy electrostatic discharges. Therefore, proper ESD precautions are recommended to avoid performance degradation or loss of functionality.

PIN CONNECTIONS

16-Lead Epoxy Plastic DIP
16-Lead SOIC

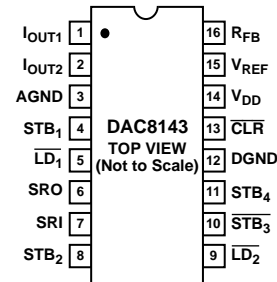

Typical Performance Characteristics–DAC8143

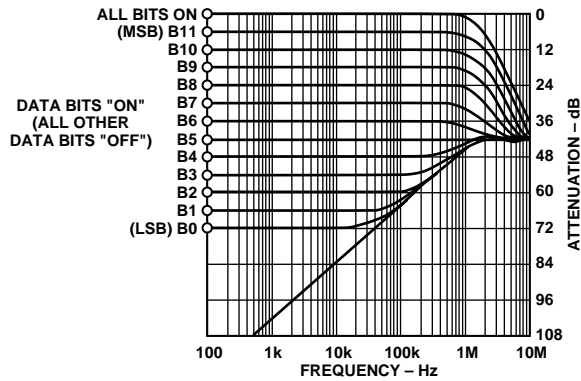

Figure 2. Multiplying Mode Frequency Response vs. Digital Code

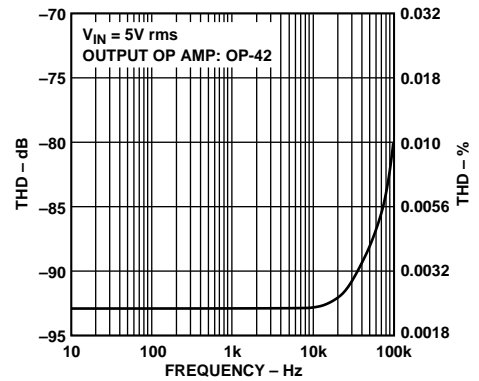

Figure 3. Multiplying Mode Total Harmonic Distortion vs. Frequency

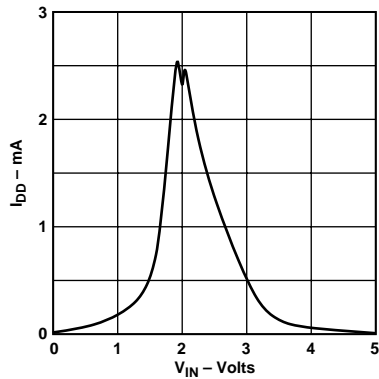

Figure 4. Supply Current vs. Logic Input Voltage

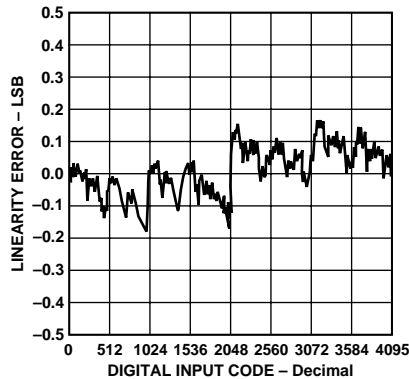

Figure 5. Linearity Error vs. Digital Code

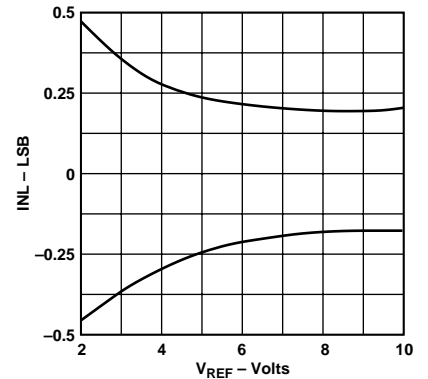

Figure 6. Linearity Error vs. Reference Voltage

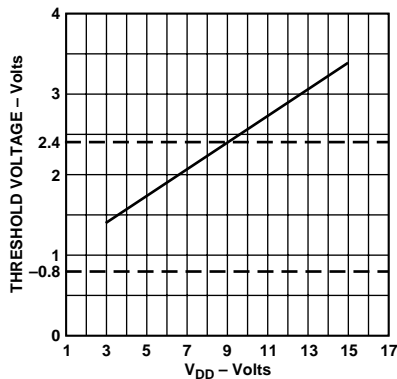

Figure 7. Logic Threshold Voltage vs. Supply Voltage

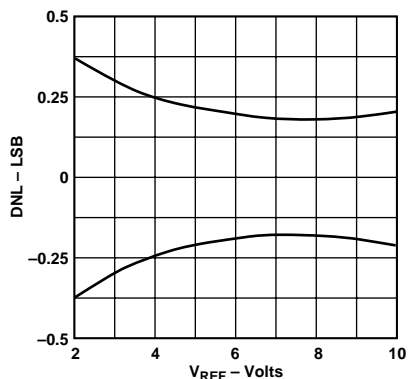

Figure 8. DNL Error vs. Reference Voltage

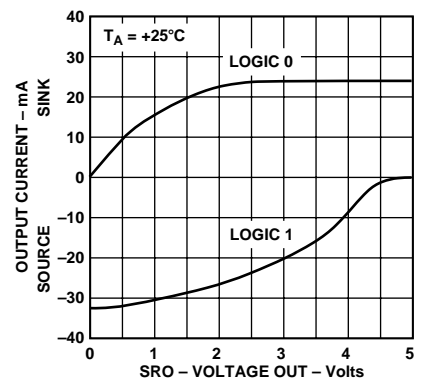

Figure 9. Digital Output Voltage vs. Output Current

DAC8143

DEFINITION OF SPECIFICATIONS

RESOLUTION

The resolution of a DAC is the number of states (2^n) into which the full-scale range (FSR) is divided (or resolved), where “n” is equal to the number of bits.

SETTLING TIME

Time required for the analog output of the DAC to settle to within 1/2 LSB of its final value for a given digital input stimulus; i.e., zero to full-scale.

GAIN

Ratio of the DAC’s external operational amplifier output voltage to the V_{REF} input voltage when all digital inputs are HIGH.

FEEDTHROUGH ERROR

Error caused by capacitive coupling from V_{REF} to output. Feedthrough error limits are specified with all switches off.

OUTPUT CAPACITANCE

Capacitance from I_{OUT1} to ground.

OUTPUT LEAKAGE CURRENT

Current appearing at I_{OUT1} when all digital inputs are LOW, or at I_{OUT2} terminal when all inputs are HIGH.

GENERAL CIRCUIT INFORMATION

The DAC8143 is a 12-bit serial-input, buffered serial-output, multiplying CMOS D/A converter. It has an R-2R resistor ladder network, a 12-bit input shift register, 12-bit DAC register, control logic circuitry, and a buffered digital output stage.

The control logic forms an interface in which serial data is loaded, under microprocessor control, into the input shift register and then transferred, in parallel, to the DAC register. In addition, buffered serial output data is present at the SRO pin when input data is loaded into the input register. This buffered data follows the digital input data (SRI) by 12 clock cycles and is available for daisy-chaining additional DACs.

An asynchronous CLEAR function allows resetting the DAC register to a zero code (0000 0000 0000) without altering data stored in the registers.

A simplified circuit of the DAC8143 is shown in Figure 10. An inverted R-2R ladder network consisting of silicon-chrome, thin-film resistors, and twelve pairs of NMOS current-steering switches. These switches steer binarily weighted currents into either I_{OUT1} or I_{OUT2} . Switching current to I_{OUT1} or I_{OUT2} yields a constant current in each ladder leg, regardless of digital input code. This constant current results in a constant input resistance at V_{REF} equal to R (typically 11 k Ω). The V_{REF} input may be driven by any reference voltage or current, ac or dc, that is within the limits stated in the Absolute Maximum Ratings chart.

The twelve output current-steering switches are in series with the R-2R resistor ladder, and therefore, can introduce bit errors. It was essential to design these switches such that the switch “ON” resistance be binarily scaled so that the voltage drop across each switch remains constant. If, for example, Switch 1 of Figure 10 was designed with an “ON” resistance of 10 Ω , Switch 2 for 20 Ω , etc., a constant 5 mV drop would then be maintained across each switch.

To further ensure accuracy across the full temperature range, permanently “ON” MOS switches were included in series with the feedback resistor and the R-2R ladder’s terminating resistor. The Simplified DAC Circuit, Figure 10, shows the location of these switches. These series switches are equivalently scaled to two times Switch 1 (MSB) and top Switch 12 (LSB) to maintain constant relative voltage drops with varying temperature. During any testing of the resistor ladder or $R_{FEEDBACK}$ (such as incoming inspection), V_{DD} must be present to turn “ON” these series switches.

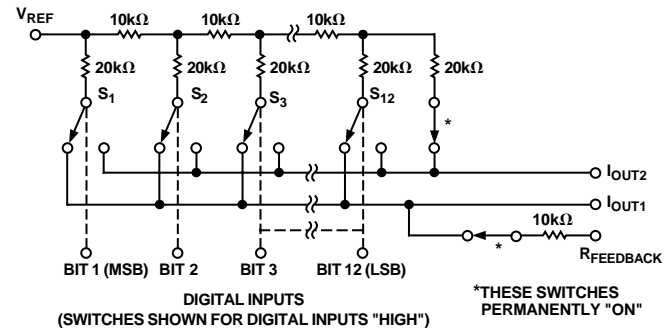

Figure 10. Simplified DAC Circuit

ESD PROTECTION

The DAC8143 digital inputs have been designed with ESD resistance incorporated through careful layout and the inclusion of input protection circuitry.

Figure 11 shows the input protection diodes. High voltage static charges applied to the digital inputs are shunted to the supply and ground rails through forward biased diodes.

These protection diodes were designed to clamp the inputs well below dangerous levels during static discharge conditions.

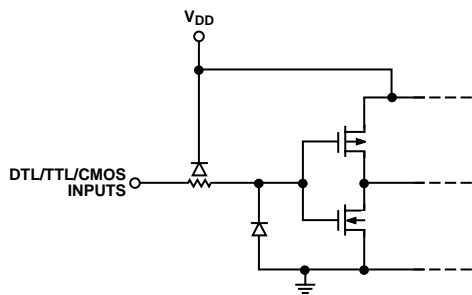

Figure 11. Digital Input Protection

EQUIVALENT CIRCUIT ANALYSIS

Figures 12 and 13 show equivalent circuits for the DAC8143's internal DAC with all bits LOW and HIGH, respectively. The reference current is switched to I_{OUT2} when all data bits are LOW, and to I_{OUT1} when all bits are HIGH. The $I_{LEAKAGE}$ current source is the combination of surface and junction leakages to the substrate. The $1/4096$ current source represents the constant 1-bit current drain through the ladder's terminating resistor.

Output capacitance is dependent upon the digital input code. This is because the capacitance of a MOS transistor changes with applied gate voltage. This output capacitance varies between the low and high values.

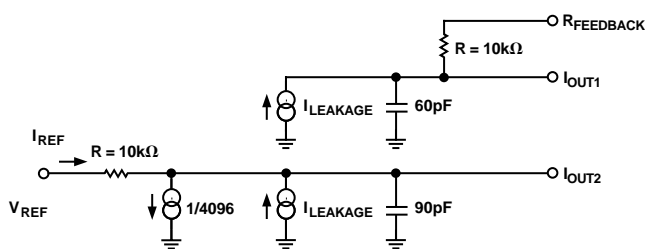

Figure 12. Equivalent Circuit (All Inputs LOW)

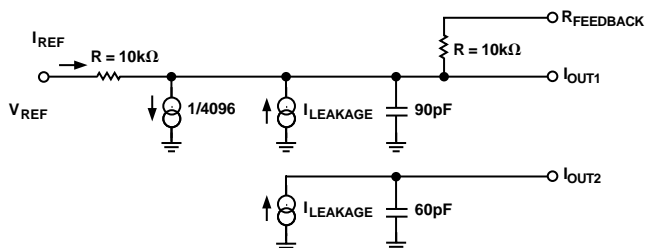

Figure 13. Equivalent Circuit (All Inputs HIGH)

DYNAMIC PERFORMANCE

ANALOG OUTPUT IMPEDANCE

The output resistance, as in the case of the output capacitance, varies with the digital input code. This resistance, looking back into the I_{OUT1} terminal, varies between $11\text{ k}\Omega$ (the feedback resistor alone when all digital input are LOW) and $7.5\text{ k}\Omega$ (the feedback resistor in parallel with approximately $30\text{ k}\Omega$ of the R-2R ladder network resistance when any single bit logic is HIGH). Static accuracy and dynamic performance will be affected by these variations.

The gain and phase stability of the output amplifier, board layout, and power supply decoupling will all affect the dynamic performance of the DAC8143. The use of a small compensation capacitor may be required when high speed operational amplifiers are used. It may be connected across the amplifier's feedback resistor to provide the necessary phase compensation to critically damp the output.

The considerations when using high speed amplifiers are:

1. Phase compensation (see Figures 16 and 17).
2. Power supply decoupling at the device socket and use of proper grounding techniques.

OUTPUT AMPLIFIER CONSIDERATIONS

When using high speed op amps, a small feedback capacitor (typically 5 pF – 30 pF) should be used across the amplifiers to minimize overshoot and ringing. For low speed or static applications, ac specifications of the amplifier are not very critical. In high speed applications, slew rate, settling time, open-loop gain and gain/phase margin specifications of the amplifier should be selected for the desired performance. It has already been noted that an offset can be caused by including the usual bias current compensation resistor in the amplifier's noninverting input terminal. This resistor should not be used. Instead, the amplifier should have a bias current that is low over the temperature range of interest.

Static accuracy is affected by the variation in the DAC's output resistance. This variation is best illustrated by using the circuit of Figure 14 and the equation:

$$V_{ERROR} = V_{OS} \left(1 + \frac{R_{FB}}{R_O} \right)$$

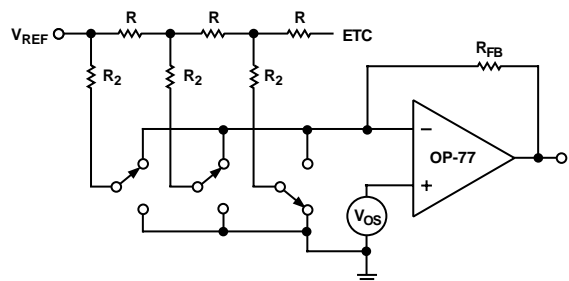

Figure 14. Simplified Circuit

DAC8143

Where R_O is a function of the digital code, and:

$$R_O = 10 \text{ k}\Omega \text{ for more than four bits of Logic 1,}$$

$$R_O = 30 \text{ k}\Omega \text{ for any single bit of Logic 1.}$$

Therefore, the offset gain varies as follows:

at code 0011 1111 1111,

$$V_{ERROR1} = V_{OS} \left(1 + \frac{10 \text{ k}\Omega}{10 \text{ k}\Omega} \right) = 2 V_{OS}$$

at code 0100 0000 0000,

$$V_{ERROR2} = V_{OS} \left(1 + \frac{10 \text{ k}\Omega}{30 \text{ k}\Omega} \right) = 4/3 V_{OS}$$

The error difference is $2/3 V_{OS}$.

Since one LSB has a weight (for $V_{REF} = +10 \text{ V}$) of 2.4 mV for the DAC8143, it is clearly important that V_{OS} be minimized, using either the amplifier's pulling pins, an external pulling network, or by selection of an amplifier with inherently low V_{OS} . Amplifiers with sufficiently low V_{OS} include OP77, OP97, OP07, OP27, and OP42.

INTERFACE LOGIC OPERATION

The microprocessor interface of the DAC8143 has been designed with multiple STROBE and LOAD inputs to maximize interfacing options. Control signals decoding may be done on chip or with the use of external decoding circuitry (see Figure 21).

Serial data is clocked into the input register and buffered output stage with STB_1 , STB_2 , or STB_4 . The strobe inputs are active on the rising edge. STB_3 may be used with a falling edge clock data.

Serial data output (SRO) follows the serial data input (SRI) by 12 clocked bits.

Holding any STROBE input at its selected state (i.e., STB_1 , STB_2 or STB_4 at logic HIGH or STB_3 at logic LOW) will act to prevent any further data input.

When a new data word has been entered into the input register, it is transferred to the DAC register by asserting both LOAD inputs.

The \overline{CLR} input allows asynchronous resetting of the DAC register to 0000 0000 0000. This reset does not affect data held in the input registers. While in unipolar mode, a CLEAR will result in the analog output going to 0 V. In bipolar mode, the output will go to $-V_{REF}$.

INTERFACE INPUT DESCRIPTION

STB_1 (Pin 4), STB_2 (Pin 8), STB_4 (Pin 11)—Input Register and Buffered Output Strobe. Inputs Active on Rising Edge. Selected to load serial data into input register and buffered output stage. See Table I for details.

STB_3 (Pin 10)—Input Register and Buffered Output Strobe Input. Active on Falling Edge. Selected to load serial data into input register and buffered output stage. See Table I for details.

\overline{LD}_1 (Pin 5), \overline{LD}_2 (Pin 9)—Load DAC Register Inputs. Active Low. Selected together to load contents of input register into DAC register.

\overline{CLR} (Pin 13)—Clear Input. Active Low. Asynchronous. When LOW, 12-bit DAC register is forced to a zero code (0000 0000 0000) regardless of other interface inputs.

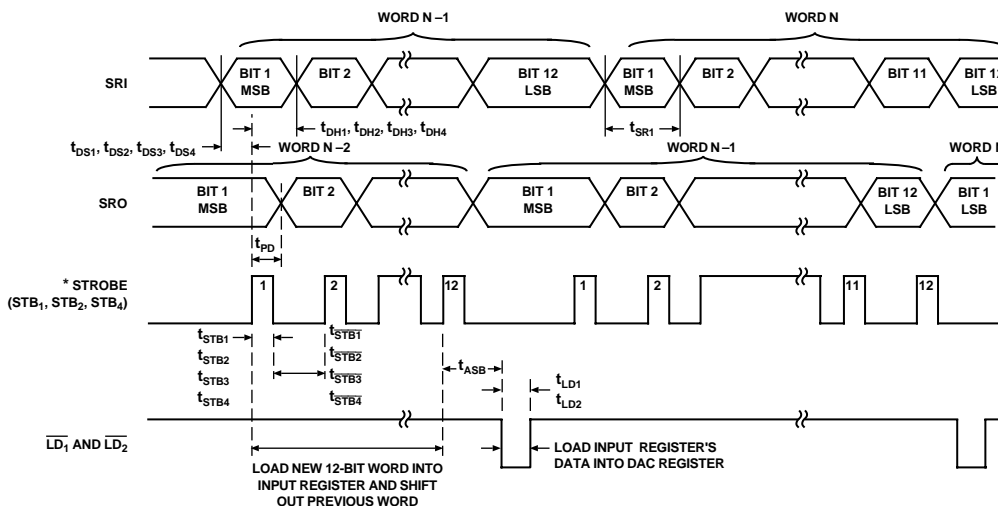

- NOTES:
- * STROBE WAVEFORM IS INVERTED IF STB_3 IS USED TO STROBE SERIAL DATA BITS INTO INPUT REGISTER.
 - ** DATA IS STROBED INTO AND OUT OF THE INPUT SHIFT REGISTER MSB FIRST.

Figure 15. Timing Diagram

Table I. Truth Table

DAC8143 Logic Inputs				DAC Register $\overline{\text{CLR}}$	Control Inputs		DAC8143 Operation	Notes
Input Register/ Digital Output		Control Inputs			$\overline{\text{LD}}_2$	$\overline{\text{LD}}_1$		
STB_4	STB_3	STB_2	STB_1					
0	1	0	f	X	X	X	Serial Data Bit Loaded from SRI into Input Register and Digital Output (SRO Pin) after 12 Clocked Bits.	2, 3
0	1	f	0	X	X	X		
0	1	0	0	X	X	X		
f	1	0	0	X	X	X		
1	X	X	X				No Operation (Input Register and SRO)	3
X	0	X	X					
X	X	1	X					
X	X	X	1					
				0	X	X	Reset DAC Register to Zero Code (Code: 0000 0000 0000) (Asynchronous Operation)	1, 3
				1	1	X	No Operation (DAC Register and SRO)	3
				1	0	0	Load DAC Register with the Contents of Input Register	3

NOTES

¹ $\overline{\text{CLR}} = 0$ asynchronously resets DAC Register to 0000 0000 0000, but has no effect on Input Register.

²Serial data is loaded into Input Register MSB first, on edges shown. f is positive edge, 1 is negative edge.

³0 = Logic LOW, 1 = Logic HIGH, X = Don't Care.

APPLICATIONS INFORMATION

UNIPOLAR OPERATION (2-QUADRANT)

The circuit shown in Figures 16 and 17 may be used with an ac or dc reference voltage. The circuit's output will range between 0 V and $+10(4095/4096)$ V depending upon the digital input code. The relationship between the digital input and the analog output is shown in Table II. The V_{REF} voltage range is the maximum input voltage range of the op amp or ± 25 V, whichever is lowest.

Table II. Unipolar Code Table

Digital Input		Nominal Analog Output (V_{OUT} as Shown in Figures 16 and 17)
MSB	LSB	
1 1 1 1	1 1 1 1 1 1 1 1 1 1 1 1	$-V_{\text{REF}} \left(\frac{4095}{4096} \right)$
1 0 0 0	0 0 0 0 0 0 0 0 0 0 0 1	$-V_{\text{REF}} \left(\frac{2049}{4096} \right)$
1 0 0 0	0 0 0 0 0 0 0 0 0 0 0 0	$-V_{\text{REF}} \left(\frac{2048}{4096} \right) = -\frac{V_{\text{REF}}}{2}$
0 1 1 1	1 1 1 1 1 1 1 1 1 1 1 1	$-V_{\text{REF}} \left(\frac{2047}{4096} \right)$
0 0 0 0	0 0 0 0 0 0 0 0 0 0 0 1	$-V_{\text{REF}} \left(\frac{1}{4096} \right)$
0 0 0 0	0 0 0 0 0 0 0 0 0 0 0 0	$-V_{\text{REF}} \left(\frac{0}{4096} \right) = 0$

NOTES

¹Nominal full scale for the circuits of Figures 16 and 17 is given by

$$FS = -V_{\text{REF}} \left(\frac{4095}{4096} \right).$$

²Nominal LSB magnitude for the circuits of Figures 16 and 17 is given by

$$LSB = V_{\text{REF}} \left(\frac{1}{4096} \right) \text{ or } V_{\text{REF}}(2^{-12}).$$

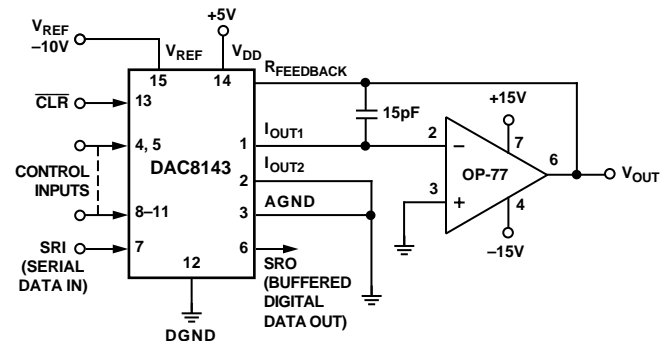

Figure 16. Unipolar Operation with High Accuracy Op Amp (2-Quadrant)

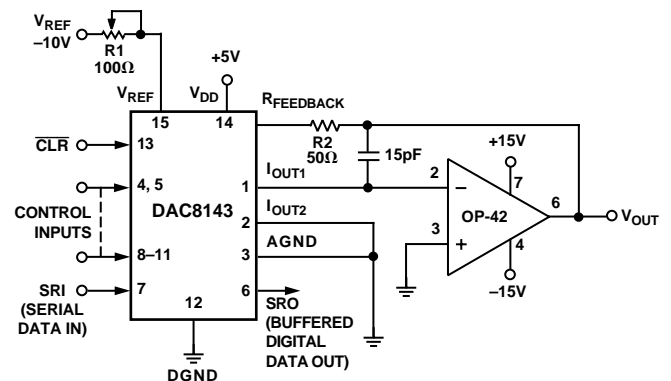

Figure 17. Unipolar Operation with Fast Op Amp and Gain Error Trimming (2-Quadrant)

DAC8143

In many applications, the DAC8143's zero scale error and low gain error, permit the elimination of external trimming components without adverse effects on circuit performance.

For applications requiring a tighter gain error than 0.024% at 25°C for the top grade part, or 0.048% for the lower grade part, the circuit in Figure 17 may be used. Gain error may be trimmed by adjusting R1.

The DAC register must first be loaded with all 1s. R1 is then adjusted until $V_{OUT} = -V_{REF}$ (4095/4096). In the case of an adjustable V_{REF} , R1 and $R_{FEEDBACK}$ may be omitted, with V_{REF} adjusted to yield the desired full-scale output.

BIPOLAR OPERATION (4-QUADRANT)

Figure 18 details a suggested circuit for bipolar, or offset binary, operation. Table III shows the digital input-to-analog output relationship. The circuit uses offset binary coding. Two's complement code can be converted to offset binary by software inversion of the MSB or by the addition of an external inverter to the MSB input.

Resistor R3, R4 and R5 must be selected to match within 0.01% and must all be of the same (preferably metal foil) type to assure temperature coefficient match. Mismatching between R3 and R4 causes offset and full-scale error.

Calibration is performed by loading the DAC register with 1000 0000 0000 and adjusting R1 until $V_{OUT} = 0$ V. R1 and R2 may be omitted by adjusting the ratio of R3 to R4 to yield $V_{OUT} = 0$ V. Full scale can be adjusted by loading the DAC register with 1111 1111 1111 and adjusting either the amplitude of V_{REF} or the value of R5 until the desired V_{OUT} is achieved.

Table III. Bipolar (Offset Binary) Code Table

Digital Input MSB	LSB	Nominal Analog Output (V_{OUT} as Shown in Figure 18)
1 1 1 1	1 1 1 1 1 1 1 1	$+V_{REF} \left(\frac{2047}{2048} \right)$
1 0 0 0	0 0 0 0 0 0 0 1	$+V_{REF} \left(\frac{1}{2048} \right)$
1 0 0 0	0 0 0 0 0 0 0 0	0
0 1 1 1	1 1 1 1 1 1 1 1	$-V_{REF} \left(\frac{1}{2048} \right)$
0 0 0 0	0 0 0 0 0 0 0 1	$-V_{REF} \left(\frac{2047}{2048} \right)$
0 0 0 0	0 0 0 0 0 0 0 0	$-V_{REF} \left(\frac{2048}{2048} \right)$

NOTES

¹Nominal full scale for the circuits of Figure 18 is given by

$$FS = V_{REF} \left(\frac{2047}{2048} \right).$$

²Nominal LSB magnitude for the circuits of Figure 18 is given by

$$LSB = V_{REF} \left(\frac{1}{2048} \right).$$

DAISY-CHAINING DAC8143s

Many applications use multiple serial input DACs that use numerous interconnecting lines for address decoding and data lines. In addition, they use some type of buffering to reduce loading on the bus. The DAC8143 is ideal for just such an application. It not only reduces the number of interconnecting lines, but also reduces bus loading. The DAC8143 can be daisy-chained with only three lines: one data line, one CLK line and one load line, see Figure 19.

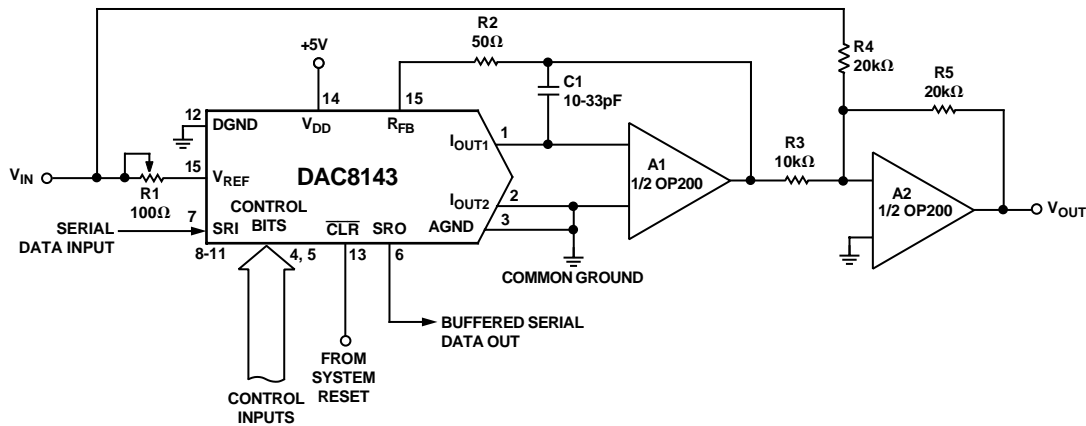

Figure 18. Bipolar Operation (4-Quadrant, Offset Binary)

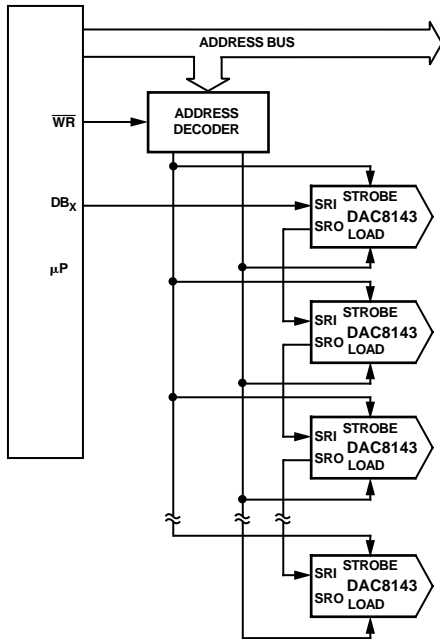

Figure 19. Multiple DAC8143s with Three-Wire Interface

ANALOG/DIGITAL DIVISION

The transfer function for the DAC8143 connect in the multiplying mode as shown in Figures 16 and 17 is:

$$V_O = -V_{IN} \left(\frac{A_1}{2^1} + \frac{A_2}{2^2} + \frac{A_3}{2^3} + \dots + \frac{A_{12}}{2^{12}} \right)$$

where A_X assumes a value of 1 for an “ON” bit and 0 for an “OFF” bit.

The transfer function is modified when the DAC is connected in the feedback of an operational amplifier as shown in Figure 20 and is:

$$V_O = \left(\frac{-V_{IN}}{2^1 + 2^2 + 2^3 + \dots + 2^{12}} \right)$$

The above transfer function is the division of an analog voltage (V_{REF}) by a digital word. The amplifier goes to the rails with all bits “OFF” since division by zero is infinity. With all bits “ON” the gain is 1 (± 1 LSB). The gain becomes 4096 with the LSB, Bit 12, “ON”.

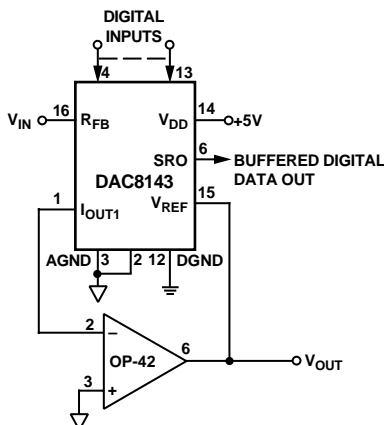

Figure 20. Analog/Digital Divider

APPLICATION TIPS

In most applications, linearity depends on the potential of I_{OUT1} , I_{OUT2} , and AGND (Pins 1, 2 and 3) being exactly equal to each other. In most applications, the DAC is connected to an external op amp with its noninverting input tied to ground (see Figures 16 and 17). The amplifier selected should have a low input bias current and low drift over temperature. The amplifier’s input offset voltage should be nulled to less than $\pm 200 \mu V$ (less than 10% of 1 LSB).

The operational amplifier’s noninverting input should have a minimum resistance connection to ground; the usual bias current compensation resistor should not be used. This resistor can cause a variable offset voltage appearing as a varying output error. All grounded pins should tie to a single common ground point, avoiding ground loops. The V_{DD} power supply should have a low noise level with no transients greater than +17 V.

It is recommended that the digital inputs be taken to ground or V_{DD} via a high value (1 M Ω) resistor; this will prevent the accumulation of static charge if the PC card is disconnected from the system.

Peak supply current flows as the digital input pass through the transition region (see Figure 4). The supply current decreases as the input voltage approaches the supply rails (V_{DD} or DGND), i.e., rapidly slewing logic signals that settle very near the supply rails will minimize supply current.

INTERFACING TO THE MC6800

As shown in Figure 21, the DAC8143 may be interfaced to the 6800 by successively executing memory WRITE instruction while manipulating the data between WRITES, so that each WRITE presents the next bit.

In this example, the most significant bits are found in memory locations 0000 and 0001. The four MSBs are found in the lower half of 0000, the eight LSBs in 0001. The data is taken from the DB_7 line.

The serial data loading is triggered by STB_4 which is asserted by a decoded memory WRITE to a memory location, R/\bar{W} , and $\Phi 2$. A WRITE to another address location transfers data from input register to DAC register.

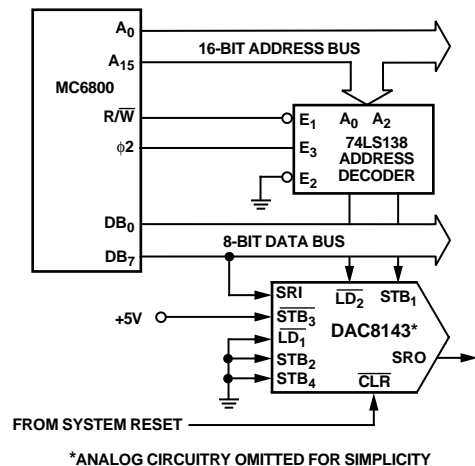

*ANALOG CIRCUITRY OMITTED FOR SIMPLICITY

Figure 21. DAC8143—MC6800 Interface

DAC8143

DAC8143 INTERFACE TO THE 8085

The DAC8143's interface to the 8085 microprocessor is shown in Figure 22. Note that the microprocessor's SOD line is used to present data serially to the DAC.

Data is strobed into the DAC8143 by executing memory write instructions. The strobe 2 input is generated by decoding an address location and \overline{WR} . Data is loaded into the DAC register with a memory write instruction to another address location.

Serial data supplied to the DAC8143 must be present in the right-justified format in registers H and L of the microprocessor.

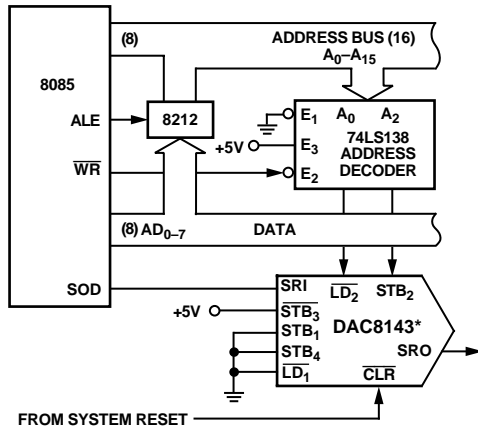

*ANALOG CIRCUITRY OMITTED FOR SIMPLICITY

Figure 22. DAC8143—8085 Interface

DAC8143 INTERFACE TO THE 68000

Figure 23 shows the DAC8143 configured to the 68000 microprocessor. Serial data input is similar to that of the 6800 in Figure 21.

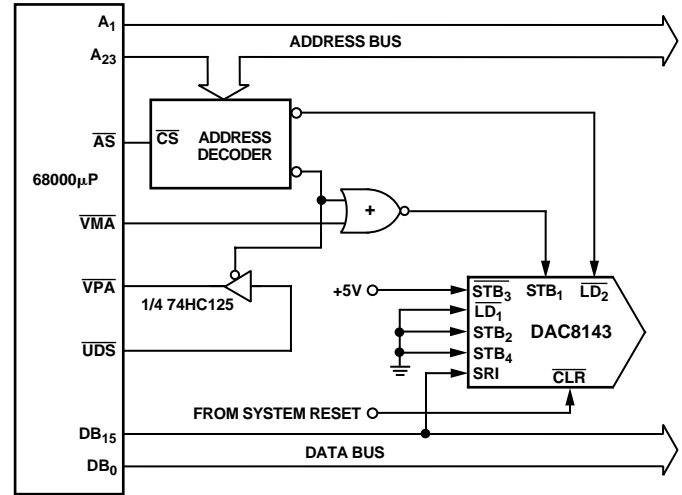
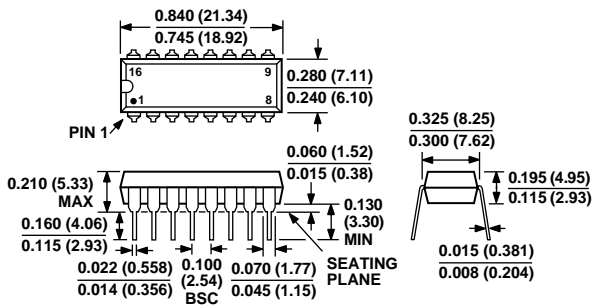

Figure 23. DAC8143 to 68000 μ P Interface

OUTLINE DIMENSIONS

Dimensions are shown in inches and (mm).

16-Lead Plastic DIP (N-16)



16-Lead SOIC (R-16W)

