

Signal Processing Codec Filter (SICOFI®)

PEB 2060

General Description

The Signal Processing Codec Filter (SICOFI) PEB 2060 is a fully integrated PCM codec (coder-decoder) and transmit/receive filter produced in advanced CMOS technology for applications in digital exchange telecommunication systems. Based on a digital filter concept the PEB 2060 provides improved transmission performance and high flexibility. It enables the control of the device's analog behavior by digital signal processing, including attractive features such as programmable trans-hybrid balancing, impedance matching, level control and frequency response correction. The device is optimized for working in conjunction with the PCM Interface Controller PEB 2052/55.

The analog input signal is A/D converted, digitally filtered and transmitted either PCM-encoded or linear. Antialiasing is done with a 2nd order Sallen-Key Prefilter (PREFI). The A/D Converter (ADC) is a modified slope adaptive interpolative coder with a sampling rate of 128 kHz. Digital downsampling to 8 kHz is done by subsequent decimation filters D1 and D2 together with the PCM bandpass filter (BP).

The digital input signal is received PCM encoded or linear, digitally filtered and D/A converted to generate the analog output signal. Digital interpolation up to 128 kHz is done by the PCM lowpass filter (LP) and the interpolation filters I1 and I2. The D/A Converter (DAC) output is fed to the 2nd order Sallen-Key Postfilter (POFI).

The high flexibility of the SICOFI is based on a variety of user programmable filter, which are analog gain adjustment AGR and AGX, digital gain adjustment GR and GX, frequency response adjustment R and X, impedance matching filter Z and the trans-hybrid balancing filter B.

The SICOFI bridges the gap between analog and digital voice signal transmission in modern telecommunication systems.

High performance oversampling Analog-to-Digital Converter (ADC) and Digital-to-Analog Converter (DAC) provide the conversion accuracy required. An analog antialiasing Prefilter (PREFI) and smoothing Postfilter (POFI) is included. The dedicated on-chip Digital Signal Processor (DSP) handles all the algorithms necessary, e.g. PCM bandpass filtering, sample rate conversion and PCM comparing. The 3-pin serial SLD-Bus interface handles digital voice transmission and SICOFI feature control. Specific filter programming is done by downloading coefficients to the Coefficient RAM (CRAM).

The 10-pin parallel signaling interface provides for a powerful per line SLIC control.

Type	Package
PEB 2060-N	P-LCC-28-1 (SMD)
PEB 2060-P	P-DIP-22-1 (not for new development)

Features

- Single-chip codec and filter
- Band limitation according to CCITT and LSSGR recommendations
- Digital signal processing techniques
- Digital voice transmission
 - PCM encoded (A-Law or μ -Law)
 - linear (16-bit 2s complement)
- Programmable digital filters for
 - impedance matching
 - transhybrid balancing
 - gain
 - frequency-response correction
- Configurable 3-pin serial interface
 - 512-kHz SLD-Bus (e.g. to PEB 2052/55)
 - burst mode with bit rates up to 8 MHz
- Programmable signaling interface with peripherals (e.g. SLIC)
- High performance A/D and D/A conversion
- Programmable analog gain
- Advanced test capabilities
 - three digital loopback modes
 - two analog loopback modes
 - on-chip sinewave generation
- No trimming or adjustment
- No external components
- Variable SICOFI master clock selection
- Signaling expansion possible
- Prepared for three-party conferencing
- Advanced low power CMOS technology

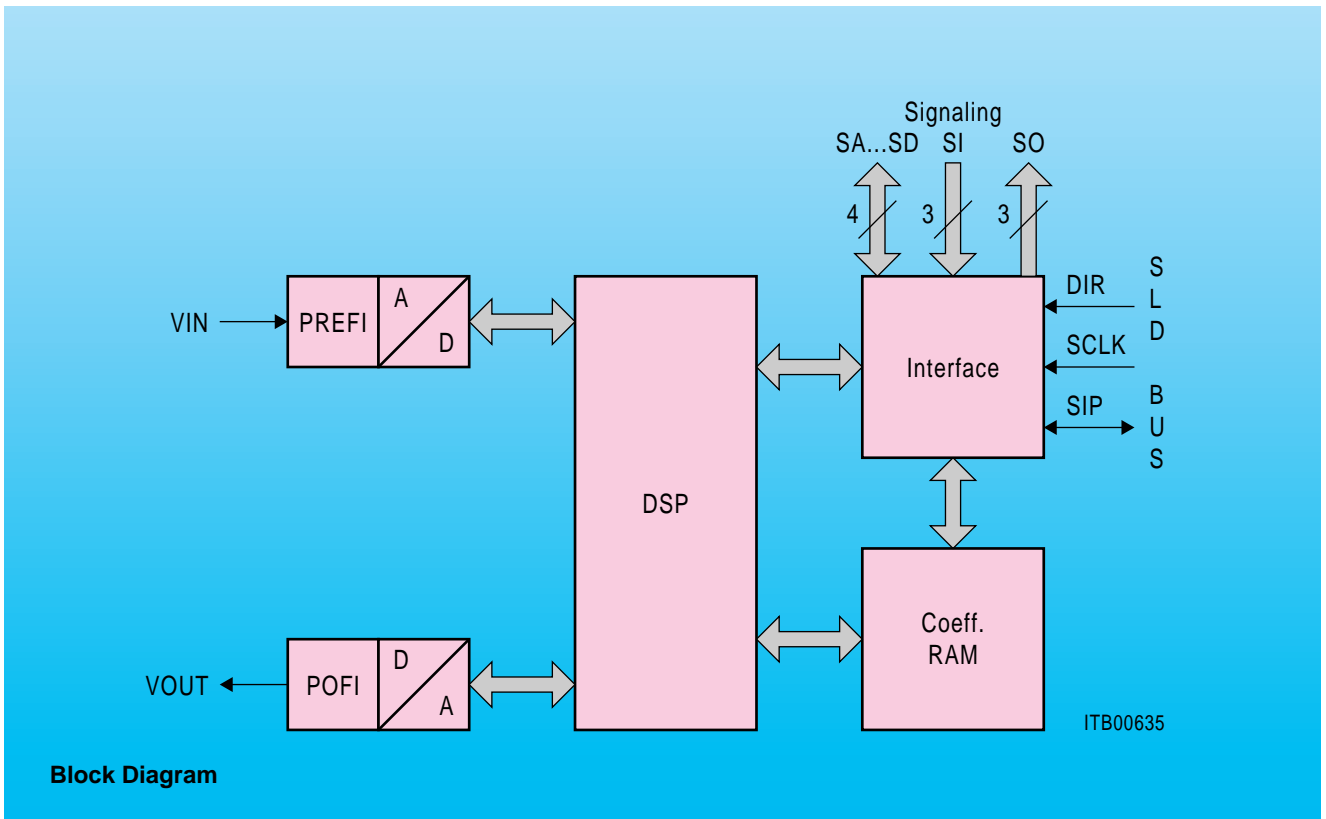

Block Diagram

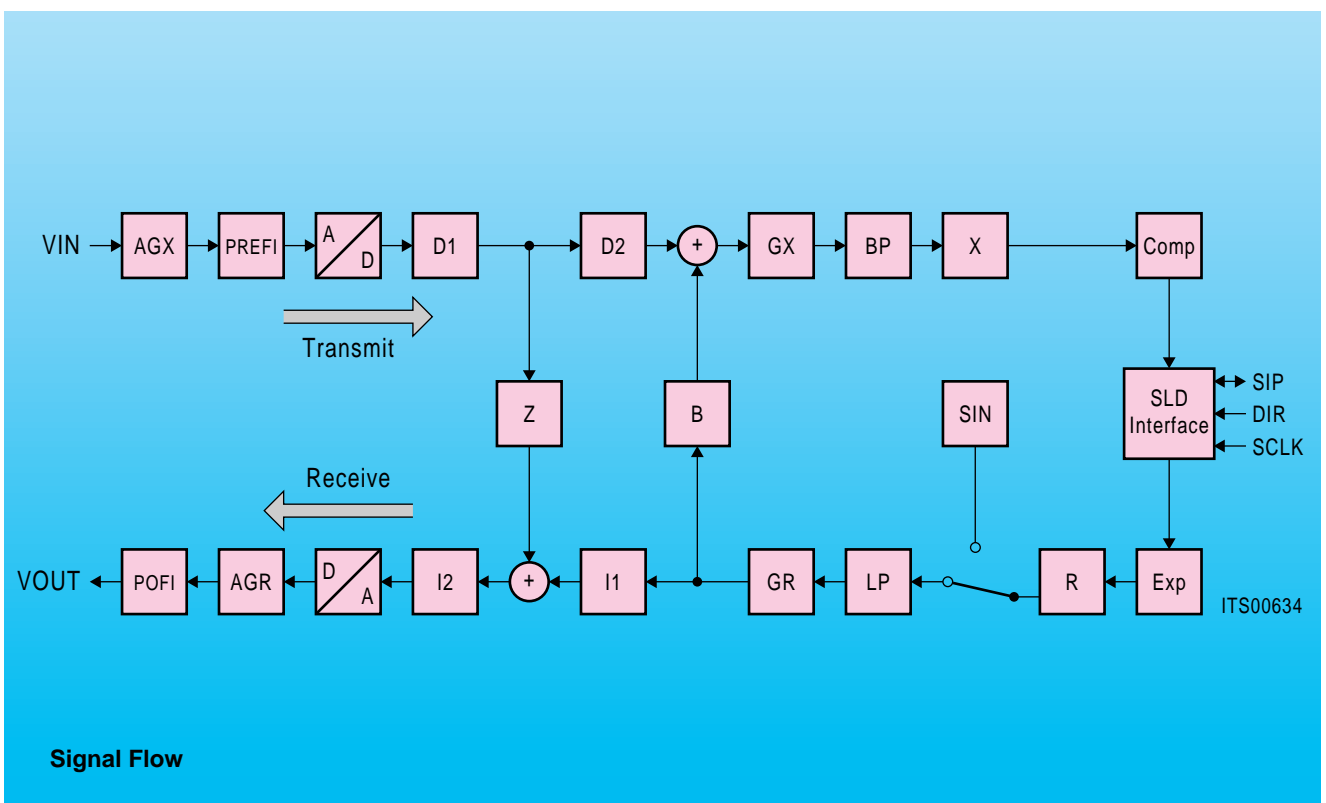

Signal Flow