

IGBT

- Low forward voltage drop
- High switching speed
- Low tail current
- Latch-up free
- Avalanche rated

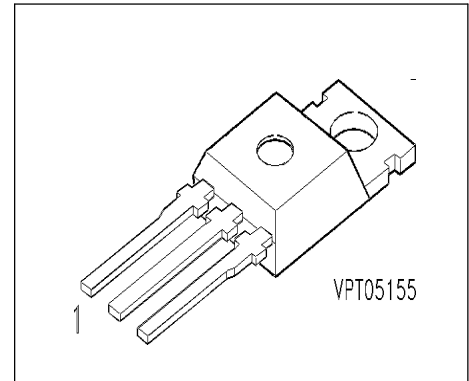

Pin 1	Pin 2	Pin 3
G	C	E

Type	V_{CE}	I_C	Package	Ordering Code
SGP10N60	600V	10A	TO-220 AB	Q67040-A

Maximum Ratings

Parameter	Symbol	Values	Unit
Collector-emitter voltage	V_{CE}	600	V
Collector-gate voltage	V_{CGR}	600	
$R_{GE} = 20 \text{ k}\Omega$			
Gate-emitter voltage	V_{GE}	± 20	
DC collector current	I_C		A
$T_C = 25 \text{ }^\circ\text{C}$		25	
$T_C = 100 \text{ }^\circ\text{C}$		10	
Pulsed collector current, $t_p = 1 \text{ ms}$	I_{Cpuls}		
$T_C = 25 \text{ }^\circ\text{C}$		50	
$T_C = 100 \text{ }^\circ\text{C}$		20	
Avalanche energy, single pulse	E_{AS}		mJ
$I_C = 10 \text{ A}$, $V_{CC} = 50 \text{ V}$, $R_{GE} = 25 \text{ }\Omega$			
$L = 350 \text{ }\mu\text{H}$, $T_j = 25 \text{ }^\circ\text{C}$		18	
Power dissipation	P_{tot}		W
$T_C = 25 \text{ }^\circ\text{C}$		125	

Preliminary data

Maximum Ratings

Parameter	Symbol	Values	Unit
Chip or operating temperature	T_j	-55 ... + 150	°C
Storage temperature	T_{stg}	-55 ... + 150	
IEC climatic category, DIN IEC 68-1	-	55 / 150 / 56	-

Thermal Resistance

Thermal resistance, junction - case	R_{thJC}	≤ 1	K/W
-------------------------------------	------------	----------	-----

Electrical Characteristics, at $T_j = 25\text{ °C}$, unless otherwise specified

Parameter	Symbol	Values			Unit
		min.	typ.	max.	

Static Characteristics

Collector-emitter breakdown voltage $V_{GE} = 0\text{ V}$, $I_C = 0.5\text{ mA}$, $T_j = -55\text{ °C}$	$V_{(BR)CES}$	600	-	-	V
Gate threshold voltage $V_{GE} = V_{CE}$, $I_C = 0.3\text{ mA}$, $T_j = 25\text{ °C}$ $V_{GE} = V_{CE}$, $I_C = 0.3\text{ mA}$, $T_j = 150\text{ °C}$	$V_{GE(th)}$	3 2	4 3	5 -	
Collector-emitter saturation voltage $V_{GE} = 15\text{ V}$, $I_C = 10\text{ A}$, $T_j = 25\text{ °C}$ $V_{GE} = 15\text{ V}$, $I_C = 10\text{ A}$, $T_j = 150\text{ °C}$	$V_{CE(sat)}$	1.6 -	2 2.3	2.5 2.8	
Zero gate voltage collector current $V_{CE} = 600\text{ V}$, $V_{GE} = 0\text{ V}$, $T_j = 25\text{ °C}$ $V_{CE} = 600\text{ V}$, $V_{GE} = 0\text{ V}$, $T_j = 150\text{ °C}$	I_{CES}	- -	- -	40 1500	μA
Gate-emitter leakage current $V_{GE} = 25\text{ V}$, $V_{CE} = 0\text{ V}$	I_{GES}	-	-	100	

Electrical Characteristics, at $T_j = 25\text{ °C}$, unless otherwise specified

Parameter	Symbol	Values			Unit
		min.	typ.	max.	

AC Characteristics

Transconductance $V_{CE} = 20\text{ V}, I_C = 10\text{ A}$	g_{fs}	2	6.7	-	S
Input capacitance $V_{CE} = 25\text{ V}, V_{GE} = 0\text{ V}, f = 1\text{ MHz}$	C_{iss}	-	580	750	pF
Output capacitance $V_{CE} = 25\text{ V}, V_{GE} = 0\text{ V}, f = 1\text{ MHz}$	C_{oss}	-	70	90	
Reverse transfer capacitance $V_{CE} = 25\text{ V}, V_{GE} = 0\text{ V}, f = 1\text{ MHz}$	C_{rss}	-	50	65	

Preliminary data
Electrical Characteristics, at $T_j = 25\text{ °C}$, unless otherwise specified

Parameter	Symbol	Values			Unit
		min.	typ.	max.	

Switching Characteristics, Inductive Load at $T_j = 150\text{ °C}$

Turn-on delay time $V_{CC} = 400\text{ V}$, $V_{GE} = 15\text{ V}$, $I_C = 10\text{ A}$ $R_{Gon} = 25\ \Omega$	$t_{d(on)}$	-	20	30	ns
Rise time $V_{CC} = 400\text{ V}$, $V_{GE} = 15\text{ V}$, $I_C = 10\text{ A}$ $R_{Gon} = 25\ \Omega$	t_r	-	25	40	
Turn-off delay time $V_{CC} = 400\text{ V}$, $V_{GE} = 15\text{ V}$, $I_C = 10\text{ A}$ $R_{Goff} = 25\ \Omega$	$t_{d(off)}$	-	270	410	
Fall time $V_{CC} = 400\text{ V}$, $V_{GE} = 15\text{ V}$, $I_C = 10\text{ A}$ $R_{Goff} = 25\ \Omega$	t_f	-	65	100	
Total turn-on loss energy * $V_{CC} = 400\text{ V}$, $V_{GE} = 15\text{ V}$, $I_C = 10\text{ A}$ $R_{Gon} = 25\ \Omega$, $T_j = 150\text{ °C}$	E_{on}	-	0.34	0.45	mJ
Total turn-off loss energy $V_{CC} = 400\text{ V}$, $V_{GE} = 15\text{ V}$, $I_C = 10\text{ A}$ $R_{Goff} = 25\ \Omega$, $T_j = 150\text{ °C}$	E_{off}	-	0.28	0.37	
Total Gate Charge $V_{CC} = 480\text{ V}$, $V_{GE} = 15\text{ V}$, $I_C = 10\text{ A}$	$Q_{G(on)}$	-	60	90	nC

* includes the reverse recovery losses caused by the FWD of the BUP400D

Package Outlines

Dimensions in mm

Weight:

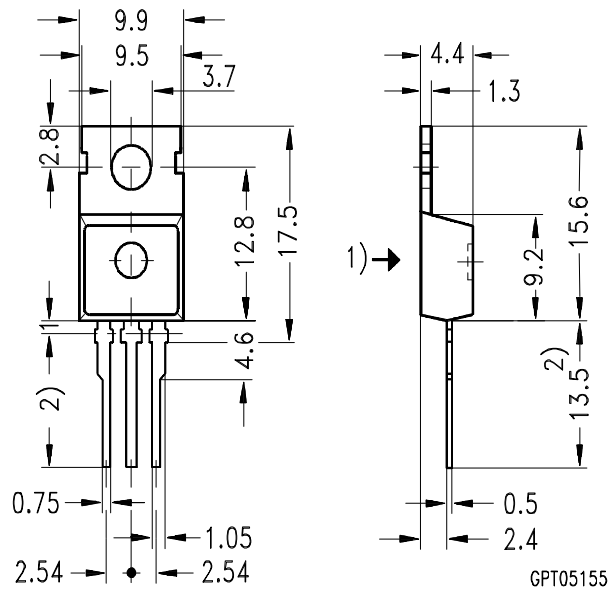

- 1) punch direction, burr max. 0.04
- 2) dip tinning
- 3) max. 14.5 by dip tinning press burr max. 0.05