

SIEMENS

Video IF with FPLL, MAC State and Vision Carrier Output

TDA 6051-5X

Preliminary Data

Bipolar IC

Features

- Active multistandard video IF with FPLL demodulator
- 12-MHz bandwidth
- MAC state
- Picture carrier output for TDA 6048-5X



Type	Ordering Code	Package
TDA 6051-5X	Q67000-A5125	P-DSO-20 (SMD)

Functional Description

Multistandard video IF with FPLL and IF-carrier output to work in conjunction with TDA 6048-5X.

Application

Multistandard TV/VTR and cable converters with mono or stereo applications.

Circuit Description

The IF circuit consists of a four-stage capacitively coupled and symmetrically designed controlled amplifier and a real synchronous demodulator with a FPLL-carrier regeneration. Two IF inputs can be selected for applications with different SAWs. The main performance of the device is the very low differential phase DP and gain DG combined with an excellent intermodulation ratio. The positive video output is used to derive the IF and tuner control voltage. The AGC threshold is set by means of a potentiometer. Dependent on the modulation polarity the video signal and the AGC are switched over. MAC state can be selected by an additional signal.

Pin Functions

Pin No.	Function
1	IF input 1a
2	IF input 1b
3	IF switch
4	Tuner AGC output
5	Tuner AGC threshold
6	Main AGC-time constant
7	Mean value AGC-time constant
8	Positive/negative modulation switch
9	Video carrier output
10	Video carrier output
11	FPLL-VCO ($2 \times$ video carrier)
12	FPLL-VCO ($2 \times$ video carrier)
13	FPLL-loop filter
14	FPLL-loop reference
15	Video output
16	MAC-standard switch
17	+ V_S supply voltage
18	Ground
19	IF input 2a
20	IF input 2b

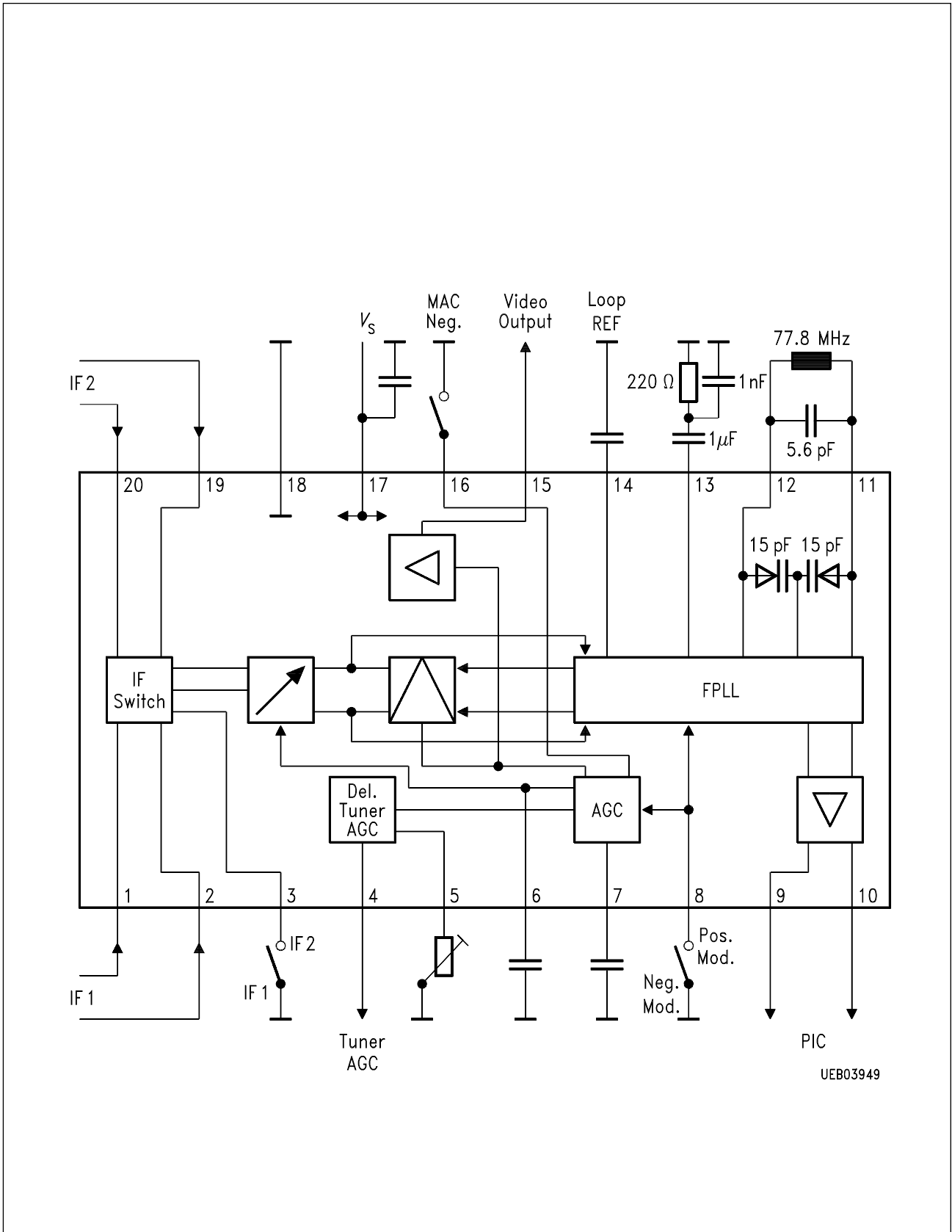

Block Diagram

Absolute Maximum Ratings

$T_A = 0$ to 70 °C

Parameter	Symbol	Limit Values		Unit
		min.	max.	
Supply voltage	V_{17}	0	13.2	V
Junction temperature	T_j		150	°C
Storage temperature	T_{stg}	- 40	125	°C
Thermal resistance (system-air)	$R_{th SA}$		77	K/W

Operating Range

Supply voltage	V_{17}	10.8	13.2	V
Supply voltage delayed tuner AGC	V_5	0.8	12	V
IF-frequency range	f_{IF}	12	80	MHz
Ambient temperature during operation	T_A	- 10	85	°C

DC Characteristics

$T_A = 0$ to 70 °C; $V_S = 12$ V

Parameter	Symbol	Limit Values			Unit	Test Condition
		min.	typ.	max.		
Total current consumption	$-I_{17}$		51		mA	
IF input	V_1, V_2, V_{19}, V_{20}	5.7	6.0	6.3	V	
IF switch H or open = IF 1 L = IF 2	$\pm I_3$ V_3 V_3	120 2.0 0.0	210	260 5.0 1.0	μ A V V	$V_3 = 0$ V, 5 V
Standard switch H level L level	$\pm I_8$ $\pm I_{16}$ V_8, V_{16} V_8, V_{16}	120 2 0	210	260 5 1	μ A V V	$V_8, V_{16} = 0$ V, 5 V
B/G standard L standard MAC standard						$V_8 = H$ $V_{16} = H$ $V_8 = L$ $V_{16} = H$ $V_8 = H$ $V_{16} = L$

AGC Voltage

Min. AGC	V_6	0.0	0.1	0.5	V	$V_{1-2}, V_{19-20} = 0$ Vrms
Max. AGC	V_6		2.8	4.0	V	$V_{1-2}, V_{19-20} = 150$ mVrms

AGC-Time Constant with Neg. Modulation

Charge current	I_6	1.1	1.4	1.9	mA	$V_6 = 2.0$ V, $V_{15} \leq 3.2$ V
Discharge current	$-I_6$	13	18	23	μ A	$V_6 = 2.0$ V, $V_{15} \geq 4.2$ V
Charge/discharge ratio	ΔI_6	55	82	140		

AGC-Time Constant with Pos. Modulation

Charge current	I_6	1.1	1.4	1.9	mA	$V_6 = 2.0$ V, $V_{15} \geq 7.0$ V
Discharge current	$-I_6$	0.15	0.25	0.35	μ A	$V_6 = 2.0$ V, 5.2 V < V_{15} < 6.5 V
Discharge current (Average control)	$-I_6$	70	85	120	μ A	$V_6 = 2.0$ V, $V_{15} < 3.9$ V
Charge/discharge ratio	ΔI_6	4000	5600	9000		

Mean Value Generation with Pos. Modulation

White level	V_7	4.9	5.7	6.5	V	$V_{1-2}, V_{19-20} = 10$ mVrms
Zero carrier level	V_7	3.3	3.7	4.1	V	$V_{1-2}, V_{19-20} = 0$ Vrms

DC Characteristics (cont'd)

Parameter	Symbol	Limit Values			Unit	Test Condition
		min.	typ.	max.		
Tuner AGC threshold	V_5	4.4	4.7	5.0	V	$R_{5-18} \rightarrow \infty$
	I_5	650	850	1050	μA	$V_5 = 0$
	V_6	2.8	3.1	3.4	V	$R_{5-18} = 10 \text{ k}\Omega$
	V_6	0.3	0.4	0.5	V	$R_{5-18} = 10 \text{ }\Omega$
Tuner AGC current max. 1 ms	$-I_4$	10	18	30	mA	$V_4 = 0.5 V_{17}, V_5 = 0.75 \text{ V}$ $V_{1-2}, V_{19-20} = 100 \text{ mVrms}$
	$-I_4$	0		10	μA	$V_4 = 0.5 V_{17}, V_5 = 4 \text{ V}$ $V_{1-2}, V_{19-20} = 10 \text{ mVrms}$

FPLL

VCO-tank circuit	V_{11}, V_{12}		3		V	
Loop reference	V_{14}	3.4	3.8	4.1	V	
Video carrier output	V_9, V_{10}	2.1	2.5	3.2	V	

Video Output Negative Modulation

Output current	$-I_{15}$	1.9	2.5	3.3	mA	$V_{15} = 5.0 \text{ V}, V_{1-2}, V_{19-20} = 10 \text{ mVrms}$, no modulation to ground via $R = 500 \text{ }\Omega$
	I_{15}	4.0			mA	
Sync pulse level	V_{15}	3.3	3.7	4.1	V	$V_{1-2}, V_{19-20} = 10 \text{ mVrms}$, no modulation
Zero carrier level	V_{15}	6.3	7.0	7.7	V	$V_6 = 3 \text{ V}$, $V_{1-2}, V_{19-20} = 0 \text{ Vrms}$

Video Output Positive Modulation (L standard)

White level	V_{15}	6.0	6.7	7.4	V	$V_{1-2}, V_{19-20} = 10 \text{ mVrms}$, no modulation
Zero carrier level	V_{15}	3.3	3.7	4.1	V	$V_6 = 3 \text{ V}$, $V_{1-2}, V_{19-20} = 0 \text{ Vrms}$

AC Characteristics

$T_A = 0$ to 70 °C; $V_S = 12$ V

Parameter	Symbol	Limit Values			Unit	Test Condition
		min.	typ.	max.		
Min. IF-input voltage (min. AGC)	V_{1-2}, V_{19-20}		45	60	μ Vrms	
Max. IF-input voltage (max. AGC)	V_{1-2}, V_{19-20}	90	100		mVrms	
IF-control range	ΔV	63	70		dB	
Video output	V_{15}	2.7	3.0	3.3	Vpp	$V_{1-2}, V_{19-20} = 10$ mVrms $R_{15-18} = 1.5$ k Ω
Changes via control range	ΔV_{15}		3	6	%	Control range = 55 dB
Changes via supply voltage range	ΔV_{15}		2	4	%	10.8 V < V_{17} < 13.2 V

Design Notes

IF-input resistance symmetrical	R_{1-2}, R_{19-20}	1.5	2	2.5	k Ω	
IF-input capacitance symmetrical	C_{1-2}, C_{19-20}		2	5	pF	
VCO voltage	V_{11-12}		700		mVpp	
Video carrier output resistance (symmetrical)	V_{9-10}		100		Ω	
Video or sound output resistance	R_{15}		70	125	Ω	
Video noise voltage ratio	S/N		60		dB	CCIR Rec 567-1
Video bandwidth	$B_{-3\text{ dB}}$	12			MHz	
Differential gain	DG			5	%	$V_{1-2}, V_{19-20} = 10$ mVrms
Differential phase	DP			2.5	$^\circ$	$V_{1-2}, V_{19-20} = 10$ mVrms
Intermodulation ratio $f_{IM} = 1.07$ MHz = $f_{TT} - f_{FT}$ sound porch = -20 dB	a_{IM}		60		dB	$V_{1-2}, V_{19-20} = 10$ mVrms
Intercarrier noise	S/N		54		dB	$V_{1-2}, V_{19-20} = 10$ mVrms, CCIR 468 FuBK, $m = 100$ % sound porch = -13 dB
Varactor diode	$C_{11, 12}$		15		pF	$V_{13} = 2.5$ V
Varactor diode	$C_{11, 12}$		7		pF	$V_{13} = 4.9$ V

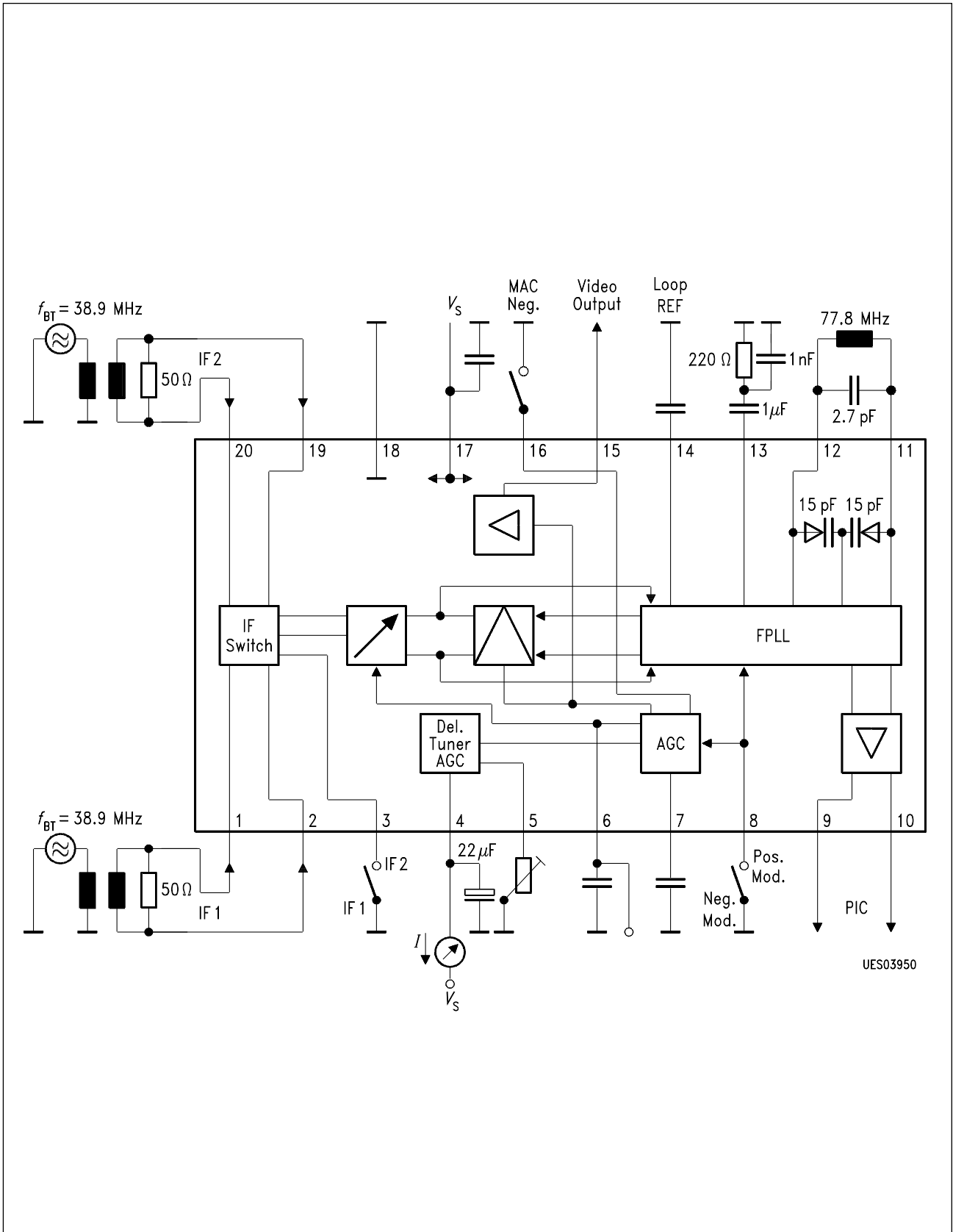

Test Circuit

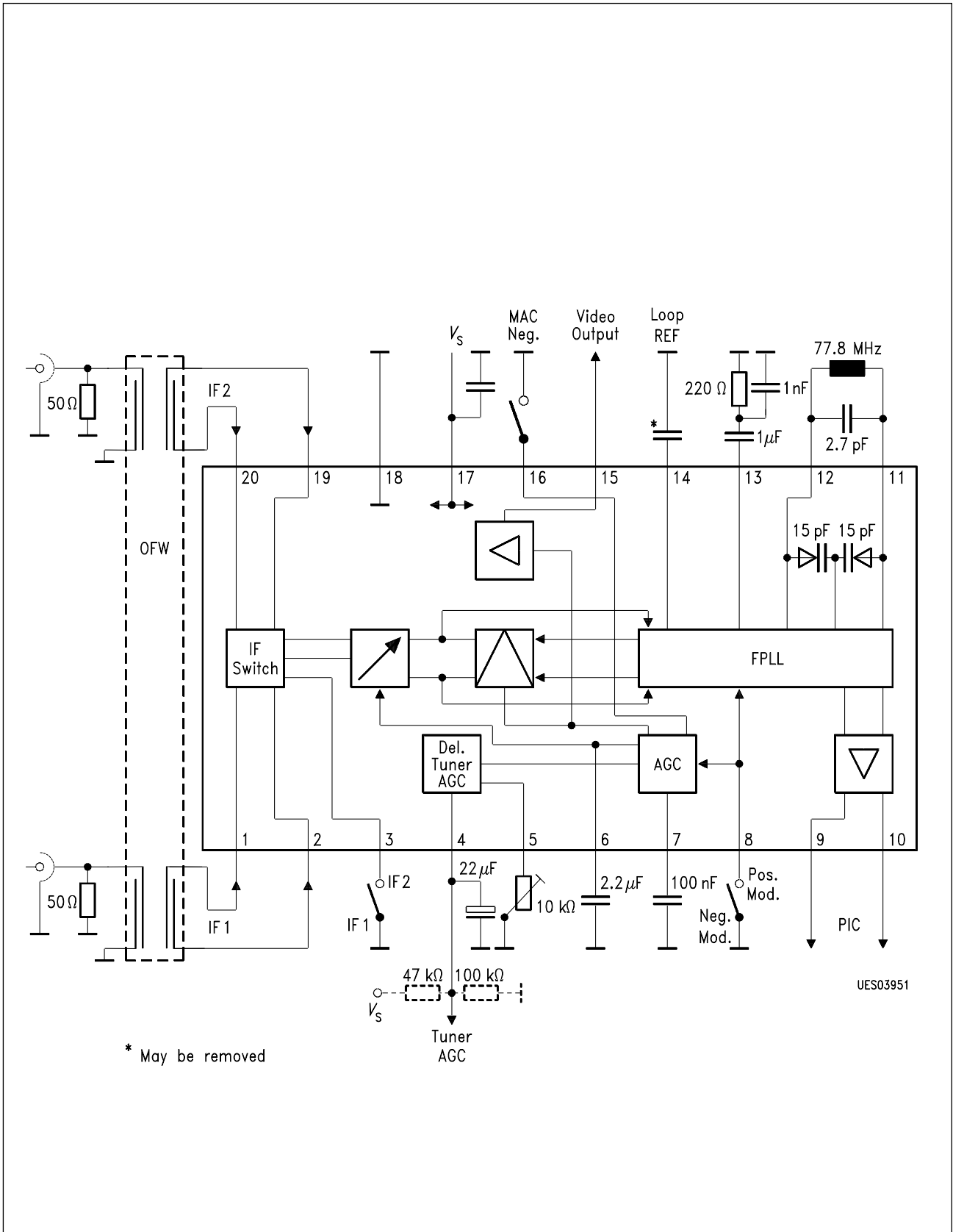

UES03951

Application Circuit