



# DG304A/305A/306A/307A

Vishay Siliconix

## CMOS Analog Switches

### FEATURES

- $\pm 15\text{-V}$  Input Range
- Fast Switching— $t_{ON}$ : 110 ns
- Low  $r_{DS(on)}$ : 30  $\Omega$
- Single Supply Operation
- CMOS Logic Levels
- Micropower: 30 nW

### BENEFITS

- Full Rail-to-Rail Analog Signal Range
- Low Signal Error
- Wide Dynamic Range
- Low Power Dissipation

### APPLICATIONS

- Low Level Switching Circuits
- Programmable Gain Amplifiers
- Portable and Battery Powered Systems

### DESCRIPTION

The DG304A through DG307A series of monolithic CMOS switches were designed for applications in communications, instrumentation and process control. This series is well suited for applications requiring fast switching and nearly flat on-resistance over the entire analog range.

applications, without sacrificing switching speed. Break-before-make switching action is guaranteed, and an epitaxial layer prevents latchup. Single supply operation (for positive switch voltages) is allowed by connecting the  $V^-$  rail to 0 V.

Designed on the Vishay Siliconix PLUS-40 CMOS process to achieve low power consumption and excellent on/off switch performance, these switches are ideal for battery powered

Each switch conducts equally well in both directions when on, and blocks up to the supply voltage when off. These switches are CMOS input compatible.

### FUNCTIONAL BLOCK DIAGRAM AND PIN CONFIGURATION

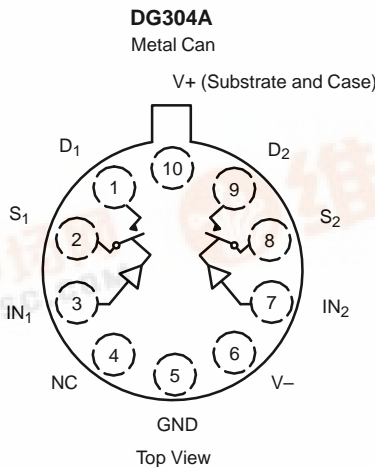
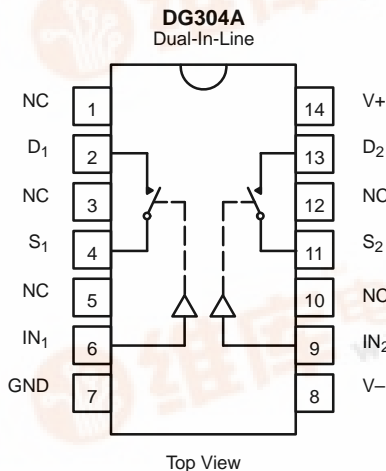

TRUTH TABLE	
Logic	Switch
0	OFF
1	ON

Logic "0"  $\leq 3.5\text{ V}$   
 Logic "1"  $\geq 11\text{ V}$



# DG304A/305A/306A/307A

Vishay Siliconix



## FUNCTIONAL BLOCK DIAGRAM AND PIN CONFIGURATION

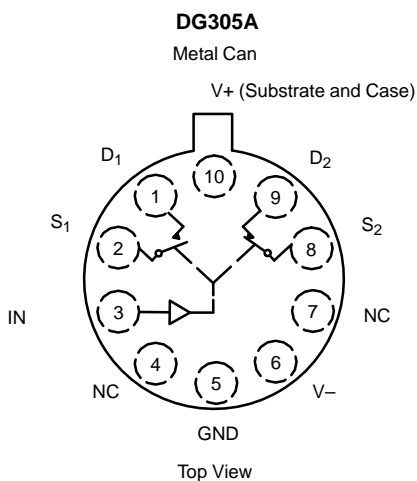
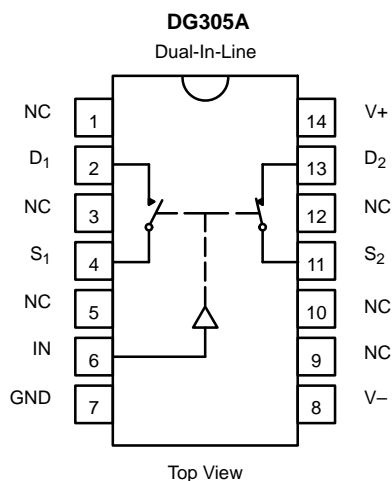

TRUTH TABLE		
Logic	SW <sub>1</sub>	SW <sub>2</sub>
0	OFF	ON
1	ON	OFF

Logic "0" ≤ 3.5 V  
Logic "1" ≥ 11 V

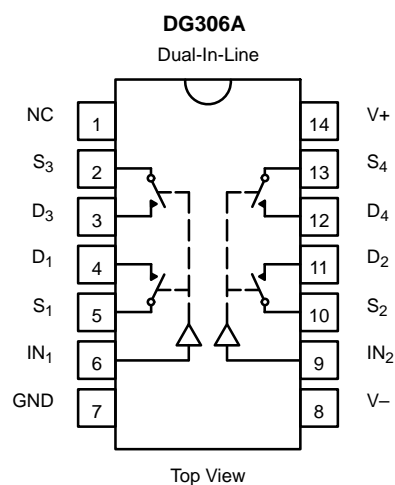

TRUTH TABLE	
Logic	Switch
0	OFF
1	ON

Logic "0" ≤ 3.5 V  
Logic "1" ≥ 11 V

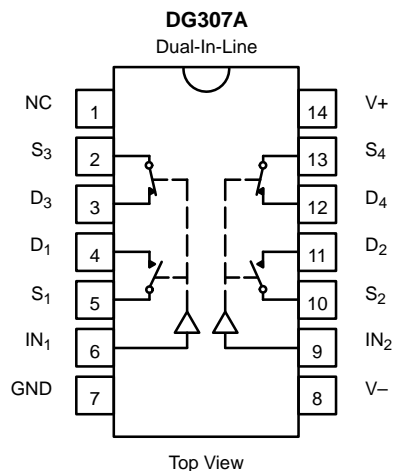

Four SPST Switches per Package

TRUTH TABLE		
Logic	SW <sub>1</sub> , SW <sub>2</sub>	SW <sub>3</sub> , SW <sub>4</sub>
0	OFF	ON
1	ON	OFF

Logic "0" ≤ 3.5 V  
Logic "1" ≥ 11 V



# DG304A/305A/306A/307A

Vishay Siliconix

ORDERING INFORMATION		
Temp Range	Package	Part Number
<b>DG304A</b>		
-0 to 70°C	14-Pin Plastic DIP	DG304ACJ
-55 to 125°C	14-Pin CerDIP	DG304AAK/883
		JM38510/11605BCA
	10-Pin Can	JM38510/11605BIA
	14-Pin Sidebrazed	JM38510/11605BCC
<b>DG305A</b>		
-55 to 125°C	14-Pin CerDIP	JM38510/11605BCA
	10-Pin Can	JM38510/11606BIC
	14-Pin Sidebrazed	JM38510/11606BCA
<b>DG306A</b>		
-0 to 70°C	14-Pin Plastic DIP	DG306ACJ
-55 to 125°C	14-Pin CerDIP	DG306AAK/883
		JM38510/11607BCA
	14-Pin Sidebrazed	JM38510/11607BCC
<b>DG307A</b>		
0 to 70°C	14-Pin Plastic DIP	DG307ACJ
-25 to 85°C	14-Pin CerDIP	DG307ABK
-55 to 125°C		DG307AAK
		DG307AAK/883
		JM38510/11608BCA
		14-Pin Sidebrazed

## ABSOLUTE MAXIMUM RATINGS

Voltages Referenced to V-	
V+ .....	44 V
GND .....	25 V
Digital Inputs <sup>a</sup> , V <sub>S</sub> , V <sub>D</sub> .....	(V-) -2 V to (V+) +2V or 30 mA, whichever occurs first
Current, Any Terminal .....	30 mA
Continuous Current, S or D (Pulsed at 1 ms, 10% duty cycle max) .....	100 mA
Storage Temperature (AAA, AAK, ABK Suffix) .....	-65 to 150°C
(ACJ Suffix) .....	-65 to 125°C

Power Dissipation <sup>b</sup>	
14-Pin Plastic DIP <sup>c</sup> .....	470 mW
14-Pin CerDIP <sup>d</sup> .....	825 mW
10-Pin Metal Can <sup>e</sup> .....	450 mW

### Notes:

- Signals on S<sub>X</sub>, D<sub>X</sub>, or IN<sub>X</sub> exceeding V+ or V- will be clamped by internal diodes. Limit forward diode current to maximum current ratings.
- All leads welded or soldered to PC Board.
- Derate 11 mW/°C above 75°C
- Derate 6.5 mW/°C above 25°C
- Derate 6 mW/°C above 75°C

# DG304A/305A/306A/307A

Vishay Siliconix



SPECIFICATIONS <sup>a</sup>									
Parameter	Symbol	Test Conditions Unless Specified $V_+ = 15\text{ V}$ , $V_- = -15\text{ V}$ $V_{IN} = 3.5\text{ V}$ or $11\text{ V}^f$	Temp <sup>b</sup>	Typ <sup>c</sup>	A Suffix -55 to 125°C		B, C Suffix -25 to 85°C 0 to 70°C		Unit
					Min <sup>d</sup>	Max <sup>d</sup>	Min <sup>d</sup>	Max <sup>d</sup>	
<b>Analog Switch</b>									
Analog Signal Range <sup>e</sup>	$V_{ANALOG}$		Full		-15	15	-15	15	V
Drain-Source On-Resistance	$r_{DS(on)}$	$V_D = \pm 10\text{ V}$ , $I_S = 10\text{ mA}$	Room Full	30		50 75		50 75	$\Omega$
Source Off Leakage Current	$I_{S(off)}$	$V_S = \pm 14\text{ V}$ $V_D = \mp 14\text{ V}$	Room Full	$\pm 0.1$	-1 -100	1 100	-5 -100	5 100	nA
Drain Off Leakage Current	$I_{D(off)}$	$V_S = \pm 14\text{ V}$ $V_D = \mp 14\text{ V}$	Room Full	$\pm 0.1$	-1 -100	1 100	-5 -100	5 100	
Drain On Leakage Current	$I_{D(on)}$	$V_D = V_S = \pm 14\text{ V}$	Room Full	$\pm 0.1$	-2 -200	2 200	-5 -200	5 200	
<b>Digital Control</b>									
Input Current with Input Voltage High	$I_{INH}$	$V_{IN} = 5\text{ V}$	Room Full	-0.001	-1 -1		-1		$\mu\text{A}$
		$V_{IN} = 15\text{ V}$	Room Full	0.001		1 1		1	
Input Current with Input Voltage Low	$I_{INL}$	$V_{IN} = 0\text{ V}$	Room Full	-0.001	-1 -1		-1		
<b>Dynamic Characteristics</b>									
Turn-On Time	$t_{ON}$	See Figure 2	Room	110		250			ns
Turn-Off Time	$t_{OFF}$		Room	70		150			
Break-Before-Make Time	$t_{OPEN}$	DG305A/307A ONLY See Figure 3	Room	50					
Charge Injection	Q	$C_L = 1\text{ nF}$ , $R_{gen} = 0$ $V_{gen} = 0\text{ V}$ , See Figure 4	Room	30					pC
Source-Off Capacitance	$C_{S(off)}$	$f = 1\text{ MHz}$ , $V_S = 0\text{ V}$ $V_S$ , $V_D = 0\text{ V}$	Room	14					pF
Drain-Off Capacitance	$C_{D(off)}$		Room	14					
Channel-On Capacitance	$C_{D(on)}$		Room	40					
Input Capacitance	$C_{IN}$		$f = 1\text{ MHz}$	$V_{IN} = 0\text{ V}$	Room	6			
		$V_{IN} = 15\text{ V}$		Room	7				
Off-Isolation	OIRR	$V_{IN} = 0\text{ V}$ , $R_L = 1\text{ k}\Omega$ $V_S = 1\text{ V}_{rms}$ , $f = 500\text{ kHz}$	Room	62					dB
Crosstalk (Channel-to-Channel)	$X_{TALK}$		Room	74					
<b>Power Supplies</b>									
Positive Supply Current	$I_+$	$V_{IN} = 15\text{ V}$ or $0\text{ V}$ (All Inputs)	Room Full	0.001		10 100		100	$\mu\text{A}$
Negative Supply Current	$I_-$		Room Full	-0.001	-10 -100		-100		

Notes:

- Refer to PROCESS OPTION FLOWCHART.
- Room = 25°C, Full = as determined by the operating temperature suffix.
- Typical values are for DESIGN AID ONLY, not guaranteed nor subject to production testing.
- The algebraic convention whereby the most negative value is a minimum and the most positive a maximum, is used in this data sheet.
- Guaranteed by design, not subject to production test.
- $V_{IN}$  = input voltage to perform proper function.



**TYPICAL CHARACTERISTICS (25°C UNLESS NOTED)**

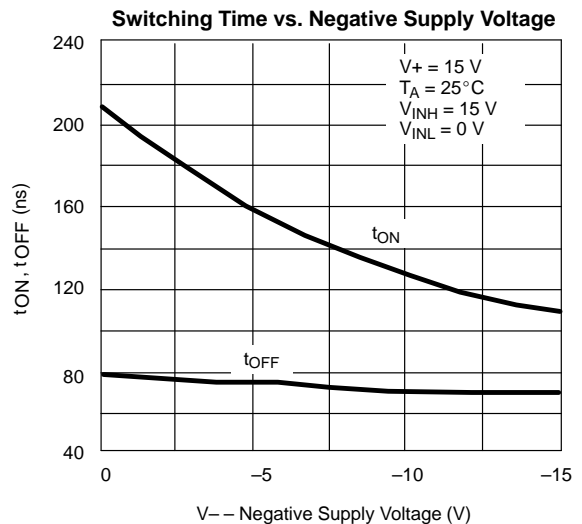
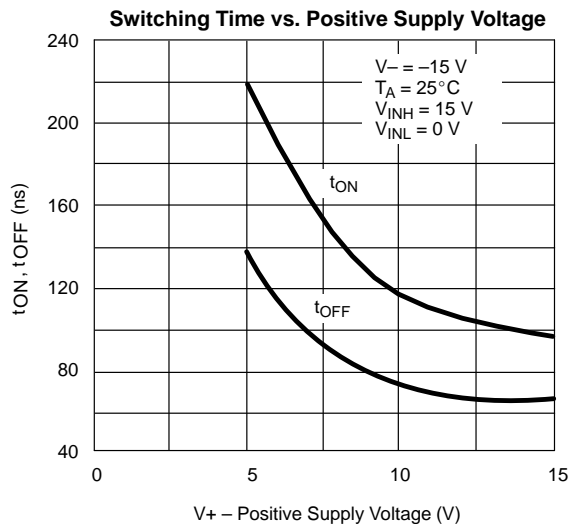
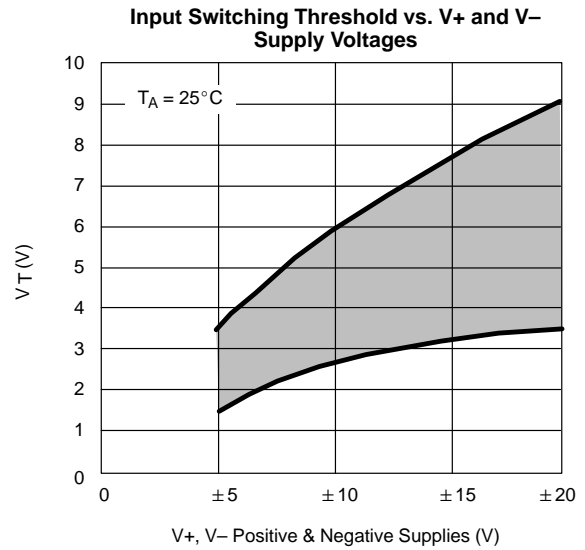
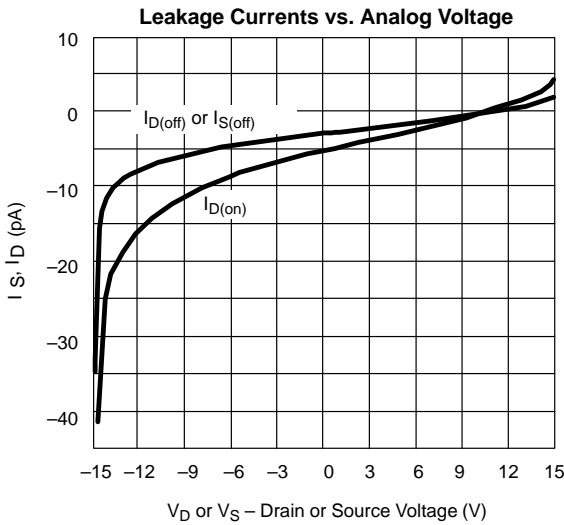
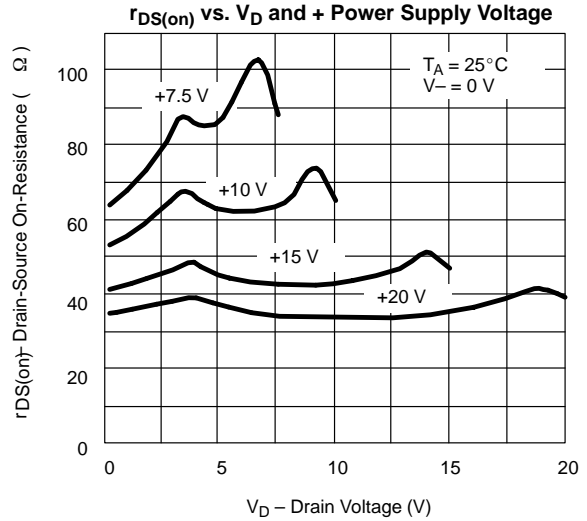
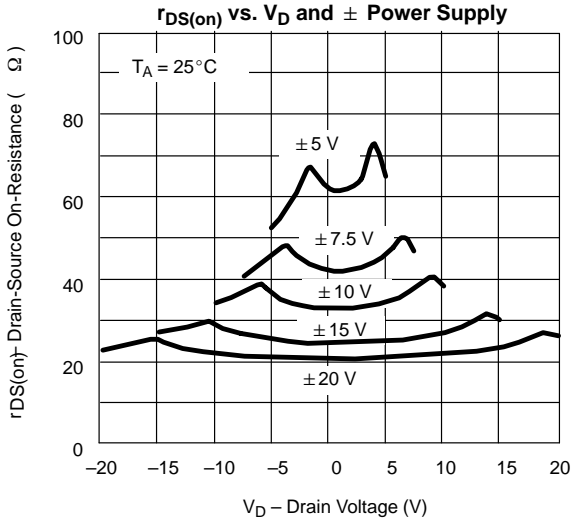

**TYPICAL CHARACTERISTICS (25 °C UNLESS NOTED)**

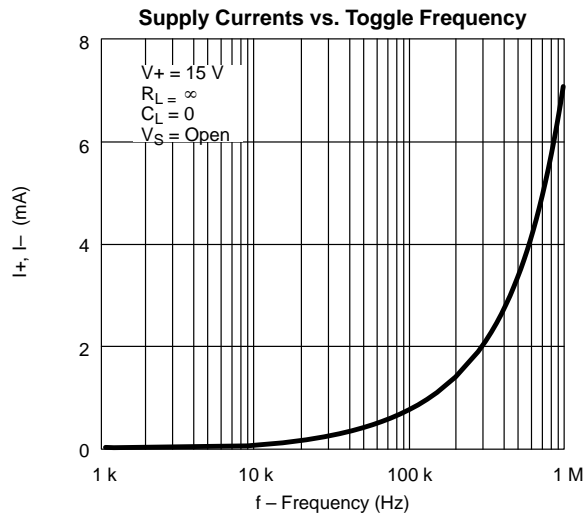

**SCHEMATIC DIAGRAM (TYPICAL CHANNEL)**

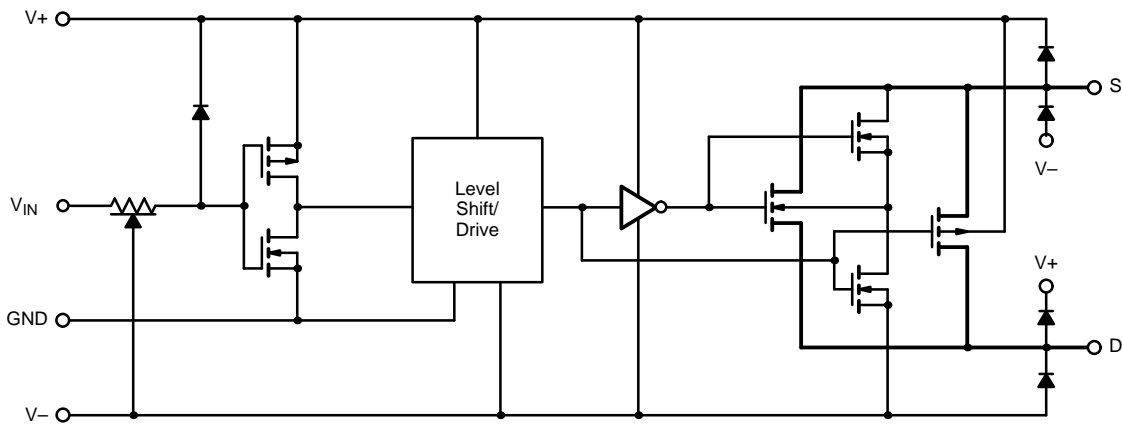

FIGURE 1.

**TEST CIRCUITS**

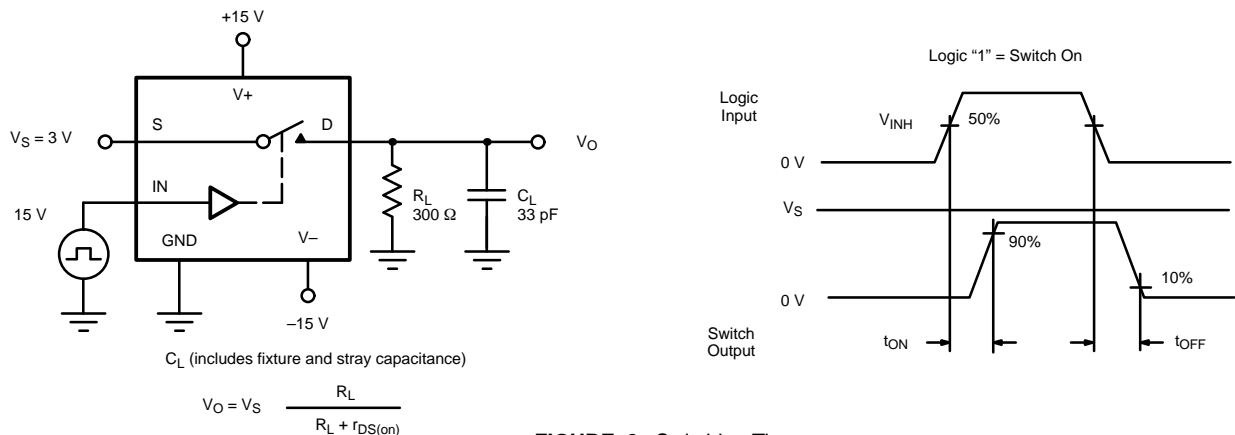

FIGURE 2. Switching Time



TEST CIRCUITS

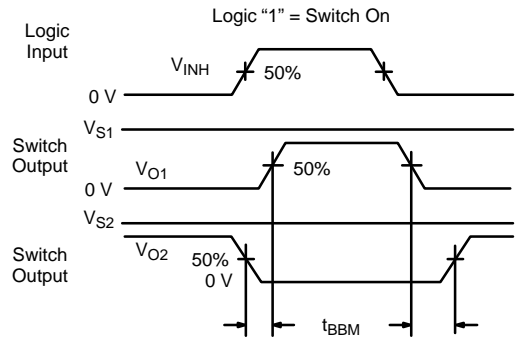
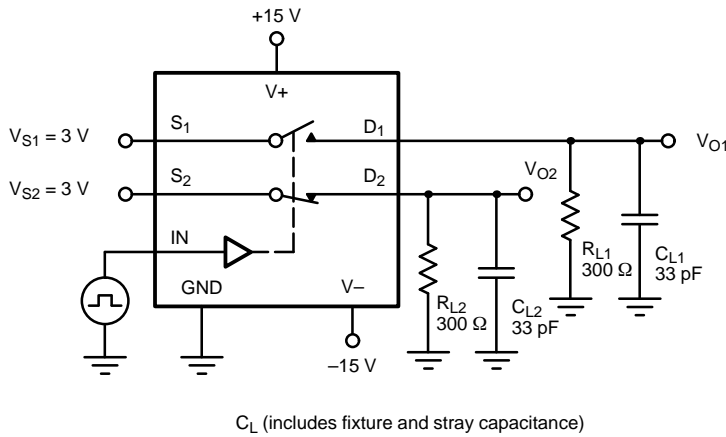

FIGURE 3. Break-Before-Make SPDT (DG305A, DG307A)

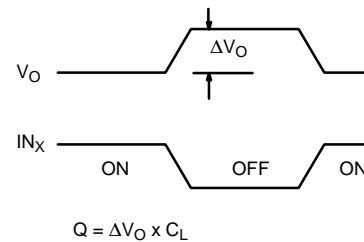
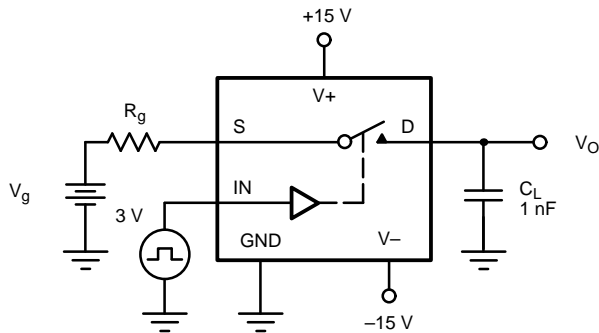

FIGURE 4. Charge Injection

APPLICATION HINTS<sup>a</sup>

V+ Positive Supply Voltage (V)	V- Negative Supply Voltage (V)	GND Voltage (V)	V <sub>IN</sub> Logic Input Voltage V <sub>INH(min)</sub> /V <sub>INL(max)</sub> (V)	V <sub>S</sub> or V <sub>D</sub> Analog Voltage Range (V)
15	-15	0	11/3.5	-15 to 15
20	-20	0	11/3.5	-20 to 20
15	0	0	11/3.5	0 to 15

Notes:

a. Application Hints are for DESIGN AID ONLY, not guaranteed and not subject to production testing.

# DG304A/305A/306A/307A

Vishay Siliconix



## APPLICATIONS

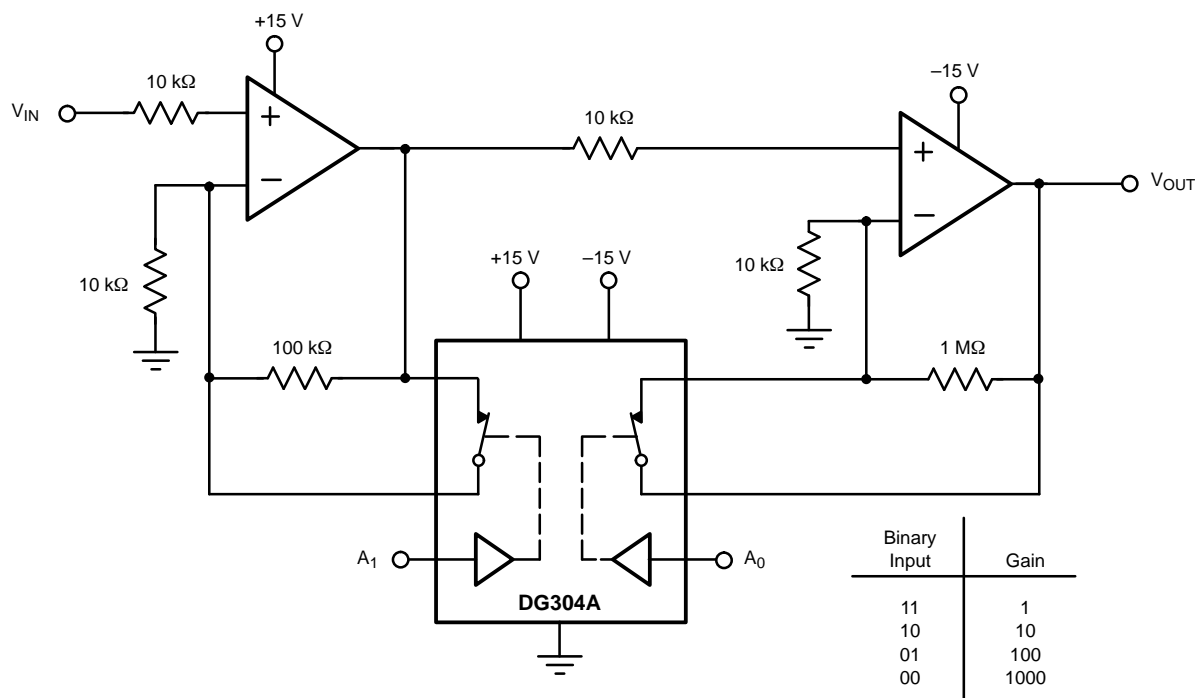

FIGURE 5. Low Power Binary to  $10^n$  Gain Low Frequency Amplifier

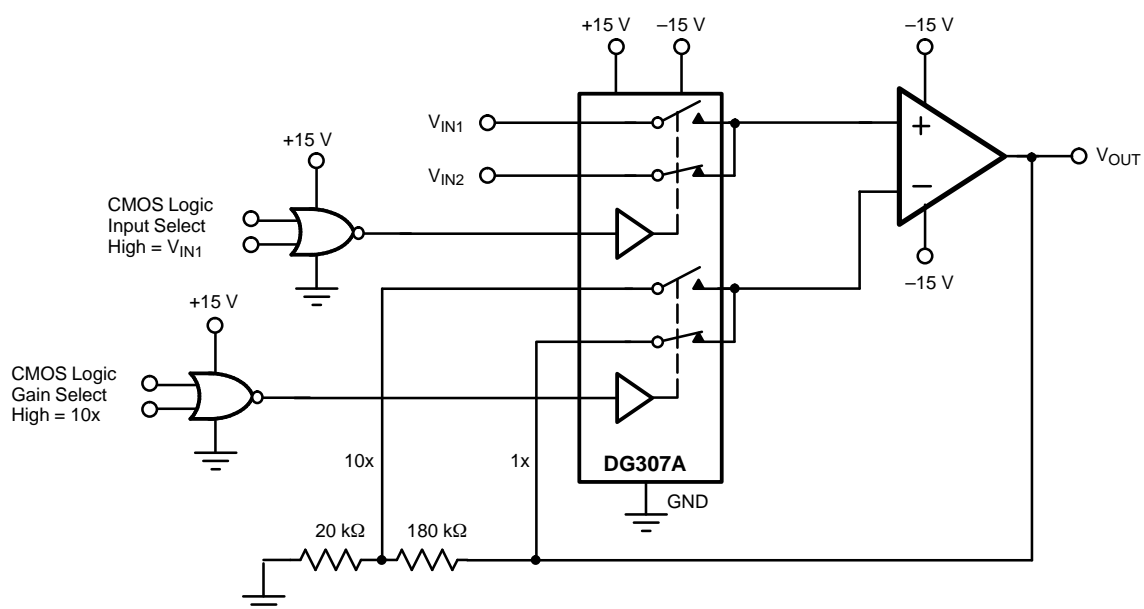

FIGURE 6. Low Power Non-Inverting Amplifier with Digitally Selectable Inputs and Gain