



LT1035M/LT1035C

Logic Controlled Regulator

FEATURES

- Two Regulated Outputs
 - + 5V at 3A
 - + 5V at 75mA
- 2% Output Voltage Tolerance
- 66dB Ripple Rejection
- 0.7% Load Regulation
- TTL and CMOS Compatible Logic Control
- 100% Thermal Burn-In on All Devices

APPLICATIONS

- Power Supply Sequencing
- Remote On/Off Power Control
- Selective System Power during Emergency Power Operation
- Memory Power Supply with Back-Up

DESCRIPTION

The LT1035 features two positive 5V regulators in the same package. The main regulator offers excellent performance while supplying load currents up to 3A, and the auxiliary regulator provides similar performance while supplying lighter loads of 75mA. The main regulator has the additional feature of being under the shutdown control of a logic signal. When the enable pin is taken to a low logic level, the main regulator shuts down and its output voltage goes to near 0V. During this command, the auxiliary output is unaffected by the main regulator's condition and continues to provide a 5V output.

The main output has current and power limiting combined with thermal shutdown to make it virtually blowout proof. The auxiliary output is not affected by the thermal shutdown mechanism or the state of the main output, allowing it to be used as a back-up in case of overloads or shorts on the main supply.

The logic input of the LT1035 (enable pin) has a 1.6V threshold and can be driven from a high source impedance. This allows it to be driven by most logic families, including TTL and CMOS.

For a 1A version of the LT1035, please see the LT1005 data sheet. For a 12V output voltage version, consult the factory.

Functional Diagram

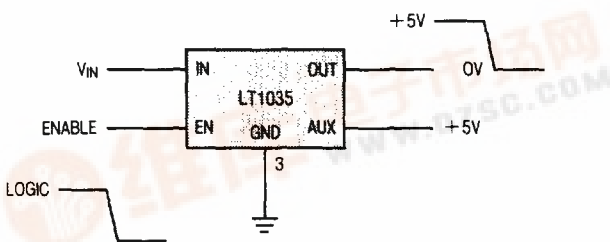

Guaranteed Load Current

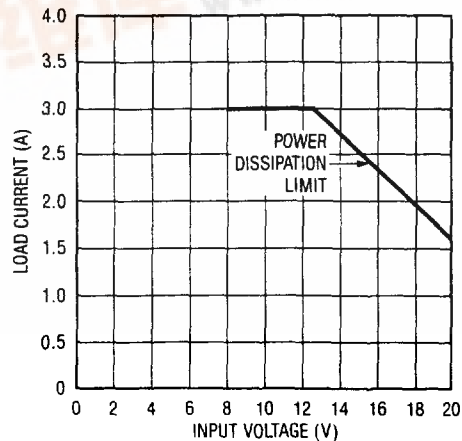

LT1035M/LT1035C

ABSOLUTE MAXIMUM RATINGS

Power Dissipation—Continuous	24W
Power Dissipation—Fault Conditions . . .	Internally Limited
Input Voltage (V_{IN})	20V
Enable Voltage (V_{EN})	20V
Operating Junction Temperature	
LT1035M	–55°C to 150°C
LT1035C	0°C to 125°C
Storage	–65°C to 150°C
Lead Temperature (Soldering, 10 sec.)	300°C

PRECONDITIONING

100% Burn-In in Thermal Limit

PACKAGE/ORDER INFORMATION

<p>BOTTOM VIEW</p> <p>4 LEAD TO-3</p>	ORDER PART NUMBER
	LT1035MK LT1035CK
<p>FRONT VIEW</p> <p>5 LEAD TO-220</p>	LT1035CT

ELECTRICAL CHARACTERISTICS Main Regulator (See Note 1)

SYMBOL	PARAMETER	CONDITIONS	LT1035M			LT1035C			UNITS
			MIN	TYP	MAX	MIN	TYP	MAX	
V_O	Output Voltage High	$T_j = 25^\circ\text{C}$	4.9	5.0	5.1	4.9	5.0	5.1	V
		$7.7\text{V} \leq V_{IN} \leq 20\text{V}$ $P_D \leq 24\text{W}$ $0\text{mA} \leq I_O \leq 3\text{A}$	● 4.8	5.0	5.2	4.8	5.0	5.2	V
	Low	$7\text{V} \leq V_{IN} \leq 12.5\text{V}$ $V_{IN} = 20\text{V}$	● 0.1	0.2	● 0.1	0.3	● 0.1	0.3	V
$\frac{\Delta V_O}{\Delta I_O}$	Load Regulation (Note 6)	$8\text{V} \leq V_{IN} \leq 12.5\text{V}$ $0 \leq I_O \leq 3\text{A}$ (Note 2)	●	10	35	●	10	35	mV
$\frac{\Delta V_O}{\Delta V_{IN}}$	Line Regulation	$7.4\text{V} \leq V_{IN} \leq 20\text{V}$ (Note 2)		0.3	2		0.3	2	mV/V
	Ripple Rejection	$50\text{Hz} \leq f \leq 500\text{Hz}$	60	70		60	70		dB
	Thermal Regulation	$\Delta P_D = 20\text{W}$ (Note 4)		0.003	0.012		0.003	0.012	%/W
I_O	Available Load Current (Note 6)	$8\text{V} \leq V_{IN} \leq 12.5\text{V}$ $V_{IN} = 20\text{V}$	● 3	4		● 3	4		A
			● 1.6	2.4		● 1.6	2.4		A
I_{SC}	Short Circuit Current	$V_{IN} = 8\text{V}$		4	6		4	6	A
		$V_{IN} = 20\text{V}$		2.5	4		2.5	4	A
V_{IN}	Minimum Input Voltage to Maintain Regulation	(Note 5) $I_O = 1\text{A}$	● 7.2	6.7		● 7.2	6.7		V
		$I_O = 3\text{A}$	● 7.7	7.2		● 7.7	7.2		V
I_Q	Quiescent Current	Output High		3	5		3	5	mA
		Output Low		2	4		2	4	mA
θ_{JC}	Thermal Resistance, Junction to Case	TO-3		1.5	2.5		1.5	2.5	$^\circ\text{C}/\text{W}$
		TO-220					2	3	$^\circ\text{C}/\text{W}$

ELECTRICAL CHARACTERISTICS Auxiliary Regulator (See Note 1)

SYMBOL	PARAMETER	CONDITIONS	LT1035M			LT1035C			UNITS
			MIN	TYP	MAX	MIN	TYP	MAX	
V_O	Output Voltage	$T_j = 25^\circ\text{C}$	4.9	5.0	5.1	4.9	5.0	5.1	V
		$7.2\text{V} \leq V_{IN} \leq 20\text{V}$ $0\text{mA} \leq I_O \leq 75\text{mA}$	●	4.8	5.0	5.2	4.8	5.0	5.2
$\frac{\Delta V_O}{\Delta I_O}$	Load Regulation	$7.2\text{V} \leq V_{IN} \leq 20\text{V}$ $0\text{mA} \leq I_O \leq 75\text{mA}$ (Note 2)	●	5	15	5	15		mV
$\frac{\Delta V_O}{\Delta V_{IN}}$	Line Regulation	$7.2\text{V} \leq V_{IN} \leq 20\text{V}$ (Note 2)	●	0.2	1 2	0.2	1 2		mV/V mV/V
	Ripple Rejection	$50\text{Hz} \leq f \leq 500\text{Hz}$		74		74			dB
I_{SC}	Short Circuit Current	$7.0\text{V} \leq V_{IN} = 20\text{V}$		140	250	140	250		mA
V_{IN}	Minimum Input Voltage to Maintain Regulation	(Note 5) $I_O \leq 10\text{mA}$	●	6.5	6.2	6.5	6.2		V
		$I_O = 75\text{mA}$	●	7.2	6.8	7.2	6.8		V

ELECTRICAL CHARACTERISTICS Logic Control (See Note 1)

SYMBOL	PARAMETER	CONDITIONS	LT1035M			LT1035C			UNITS	
			MIN	TYP	MAX	MIN	TYP	MAX		
V_{EN}	Enable Threshold Voltage	$7.0\text{V} \leq V_{IN} \leq 20\text{V}$ $T_j = 25^\circ\text{C}$		1.45	1.6	1.7	1.45	1.6	1.7	V
		●	1.3	1.6	1.8	1.3	1.6	1.8	V	
	Enable Pin Current	$V_{EN} \leq 1\text{V}$ (Note 3)		0	1.5	6	0	1.5	6	μA
		$V_{EN} \geq 2.4\text{V}$		0	1	0	1		μA	

The ● denotes the specifications which apply over the full operating temperature range.

Note 1: Unless otherwise indicated, these specifications apply for $V_{IN} = 10\text{V}$, $I_O = 0\text{mA}$, and $T_j = 25^\circ\text{C}$.

Note 2: Line and load regulation is measured using a low duty cycle pulse, causing little change in the junction temperature. Effects due to thermal gradients and device heating must be taken into account separately.

Note 3: When the enable pin is at a low logic level, current flows out of the enable pin.

Note 4: Pulse length for this measurement is 20ms.

Note 5: Input voltage is reduced until output drops by 100mV from its initial value.

Note 6: See "Guaranteed Load Current" graph.

LT1035M/LT1035C

TYPICAL PERFORMANCE CHARACTERISTICS

Minimum Input-Output Differential of Main Output

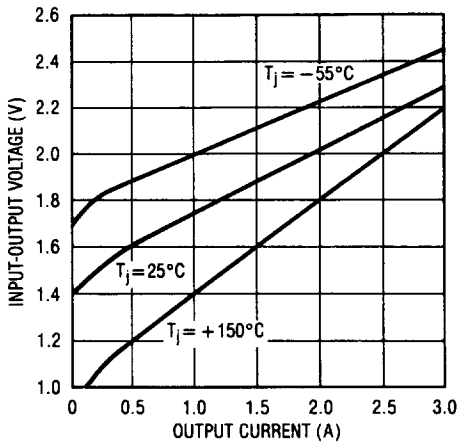

Minimum Input-Output Differential of Auxiliary Output

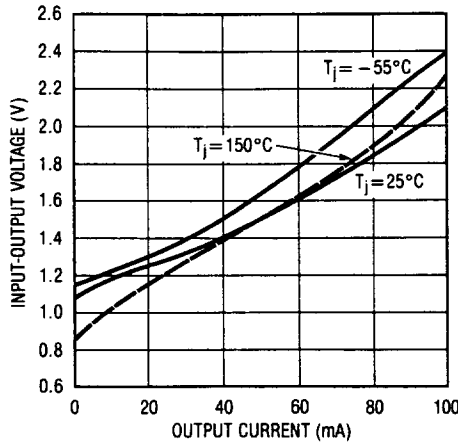

Maximum Available Load Current—Main Output

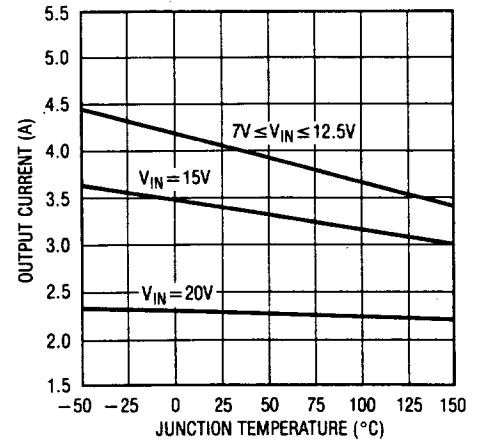

Short Circuit Output Current

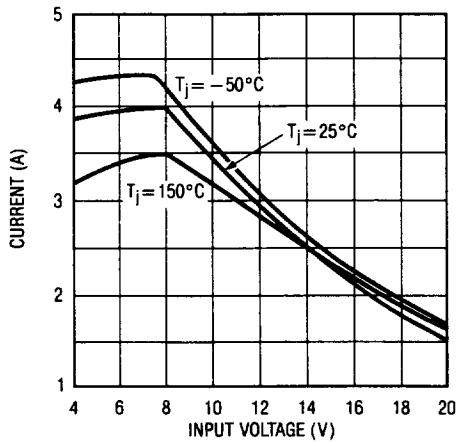

Load Transient Response

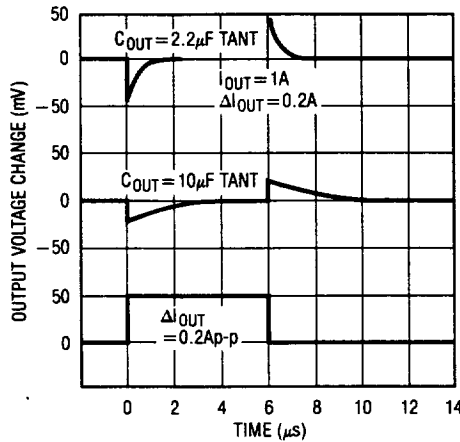

Line Transient Response

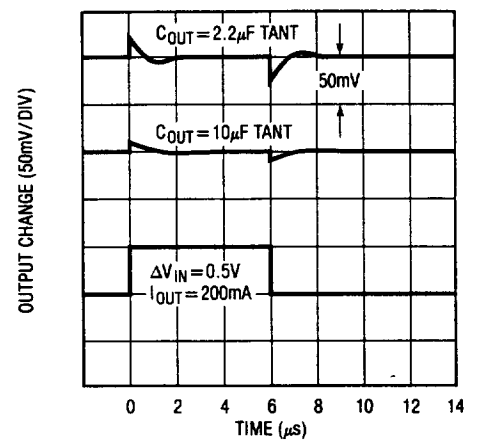

Output Voltage as Function of Temperature

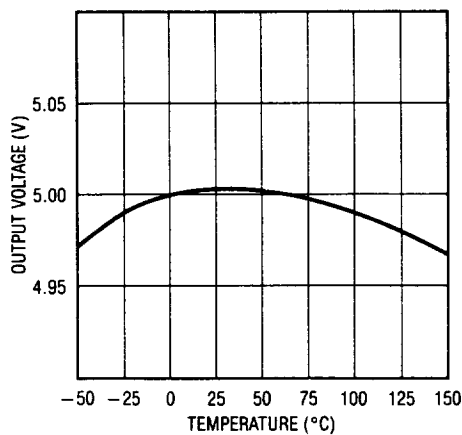

Ripple Rejection

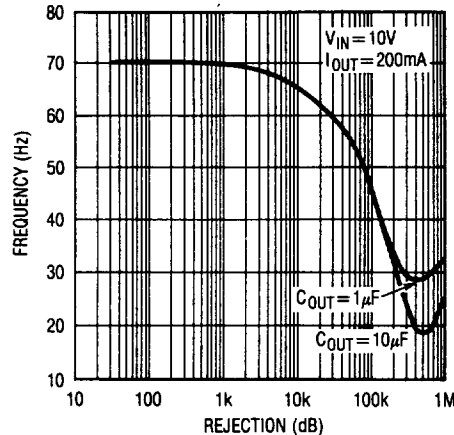

Output Impedance

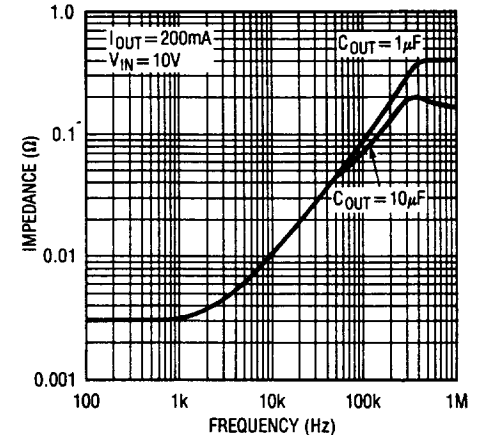

TYPICAL PERFORMANCE CHARACTERISTICS

Enable Pin Characteristics

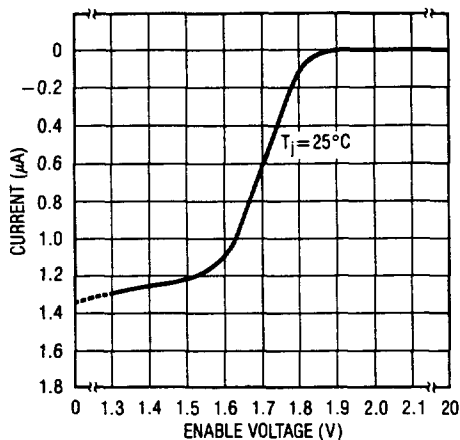

Enable Threshold

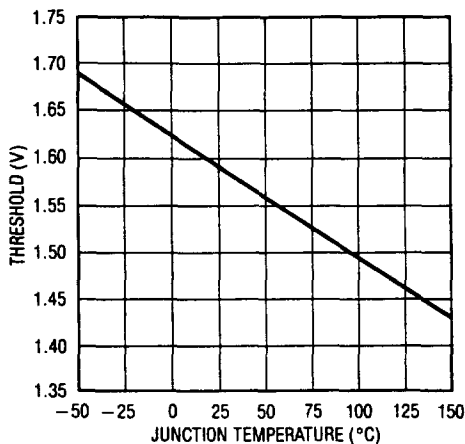

Output Switching Characteristics

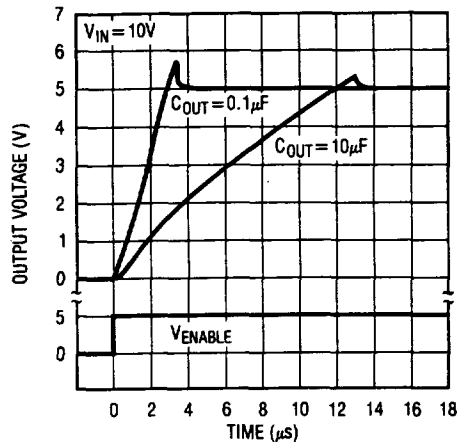

Output Characteristics in Low State

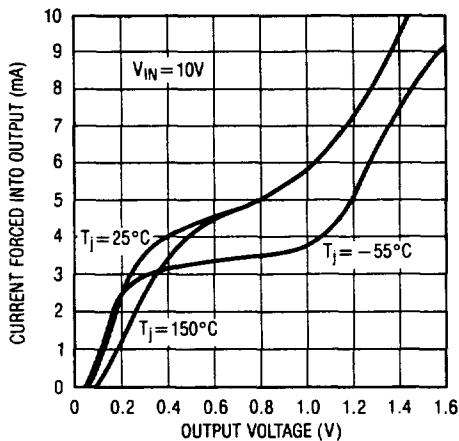

Quiescent Current

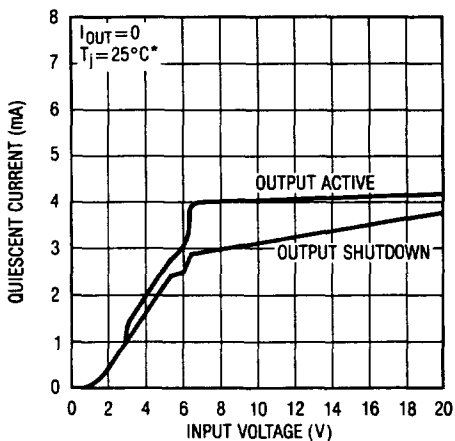

* I_Q IS NEARLY INDEPENDENT OF TEMPERATURE

Output Noise

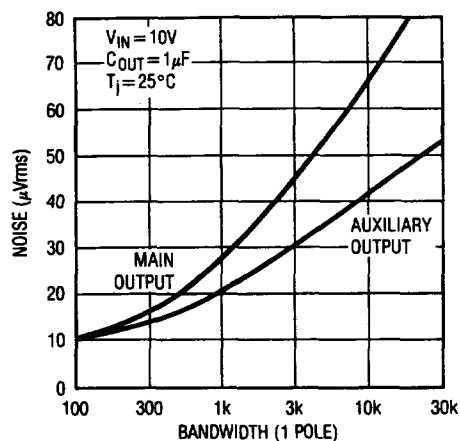

LT1035M/LT1035C

APPLICATIONS INFORMATION

General Information

The LT1035 is a dual output 5V regulator. The main output is capable of delivering up to 3A of load current and can be shut down with a logic signal. The auxiliary output supplies a minimum of 75mA and is unaffected by the logic signal. The outputs are trimmed to $\pm 2\%$ initial tolerance and exhibit excellent line and load regulation.

The logic control feature makes the LT1035 ideal for many system applications where it is desirable to power-up a portion of the system for a period of time, and then power the system down during a standby operation. As an example, the LT1035 could be used to activate various memory space locations only as needed, thus saving substantial power dissipation and other cooling costs. The LT1035 could also be used to power microcomputers such as the 8048 series. The auxiliary supply can be used for RAM keep-alive during power-down operation. Additional power savings can be accomplished by using the LT1035 to power PROM, EPROM, and E²PROM devices. During program load or look-up table operations, the ROM type device can be activated and its contents placed in RAM, and then the ROM power can be removed. Or for high speed but low power data acquisition systems, the power could be applied to fast memory, then the data transferred to CMOS memory. The main regulator can then be shut down and the CMOS memory can be powered by the auxiliary for lower power dissipation. Other applications such as multiple power supply sequencing, elimination of expensive AC and DC power switches, delayed start applications, switching 5V DC loads, and many others are now easily accomplished.

Timing functions, such as delayed power-up or power-down, can also be performed directly at the enable pin.

Because a logic low on the enable pin shuts down the main regulator, feedback from output to enable can be used to generate hysteresis or latching functions.

The low quiescent current drain of the LT1035 makes it useful in battery-powered or battery back-up applications. The enable pin can be used as a "low battery" detector or to shut down major portions of system power,

allowing memory portions to continue to operate from the auxiliary output. At low output currents, the auxiliary output will regulate with input voltage typically as low as 6.1V, giving maximum battery life.

Good design practice with all regulators is to bypass the input and output terminals. A $2\mu\text{F}$ solid tantalum at the input and at both outputs is suggested. For the applications which follow, the bypass capacitors are still recommended, but for simplicity are not shown on the diagram. It is also recommended that for maximum noise immunity the voltage enable pin be tied high if it is unused. It can be tied directly to V_{IN} , as shown in Figure 1, or to the auxiliary output. If the enable pin is left open, it will float to a high logic level of approximately 1.6V and the main output regulator will be at 5V.

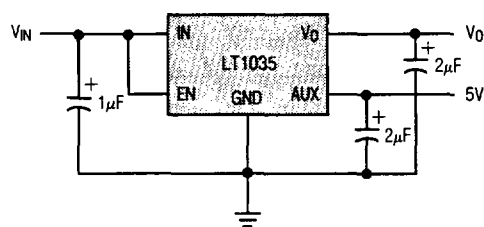

Figure 1

The enable pin is fully protected against input voltages up to 20V, even if the power input voltage is zero.

The basic shutdown control circuit uses a direct gate drive or an open collector driver and a pull-up resistor which are tied to V_{AUX} , as shown in Figure 2.

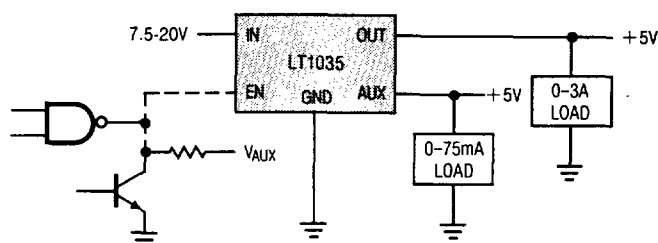

Figure 2

APPLICATIONS INFORMATION

Driving the Enable Pin

The enable pin equivalent schematic is shown in Figure 3. Basically, enable pin current is zero above the threshold and about $1.5\mu\text{A}$ below the threshold, flowing out of the pin. Standard logic, such as TTL and CMOS, will interface directly to the enable pin, even if the logic output swing is higher than the input voltage (V_{IN}) to the regulator. 15V CMOS can be used to drive the enable pin, even if the regulator is not powered up, without loading the CMOS output.

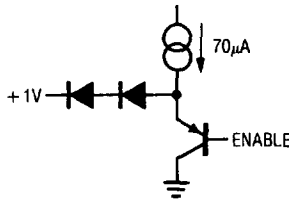

Figure 3

Timing functions, such as delayed power-up or power-down, can be implemented by driving the enable pin with an RC network. The current flowing out of the enable pin should not be used as the timing current in delayed power-up applications as it is temperature sensitive and varies somewhat from device to device. Instead, a resistor tied to the auxiliary output, the input, or to a logic signal should be used. The timing resistor chosen should provide at least $25\mu\text{A}$ of current to "swamp out" the effects of the internal current.

Main Output Current/Voltage Characteristics

Following a high to low transition at the enable pin, the main regulator output will begin to drop after a delay of approximately $0.4\mu\text{s}$. With no capacitive load, the output will fall to zero in approximately $0.8\mu\text{s}$ ($R_L = 2\Omega - 100\Omega$). With a capacitive load, fall time is limited by the RC product of the load and the output capacitance. For light loads ($R_L > 400\Omega$), the discharge time is controlled by an internal current pull-down of 15mA for output voltages down to 1.5V . Below 1.5V , the pull-down current drops to $\approx 4\text{mA}$. The DC output voltage in the shutdown mode is approximately 0.07V for input voltages (V_{IN}) up to 12V . If V_{IN} is 20V , the output during shutdown will be approximately 0.15V due to an internal current path in the regulator.

Output Characteristics in Low State

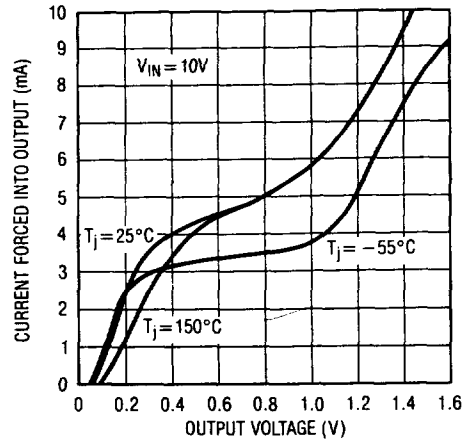

Figure 4

The user should note that the output in the low state can only sink about 3mA . If current is forced into the output, the output voltage will rise to 1V at 5mA and about 1.5V at 10mA . With no output capacitor, the rise time of the main output is about $3\mu\text{s}$. With an output capacitor, rise time is limited by the short circuit current of the LT1035 and the load capacitance; $t_r \approx (C)(5\text{V})/4\text{A}$. A $10\mu\text{F}$ output capacitor slows the output rise time to approximately $12\mu\text{s}$.

Output Current

The main output current limits at about 4A for input voltages below 12.5V . Internal foldback, or "power limiting", circuitry detects the input-output voltage differential and reduces current limit for input to output voltages exceeding 7.5V . With 20V input, for instance, short circuit current is reduced to $\approx 2.4\text{A}$.

An additional feature of the LT1035 is that the auxiliary supply does not incorporate, nor is it affected by, thermal shutdown. Any fault condition of the main regulator will not affect the auxiliary output voltage.

The following applications circuits will serve to indicate the versatility of the LT1035.

LT1035M/LT1035C

TYPICAL APPLICATIONS

First-On, Last-Off Sequencing

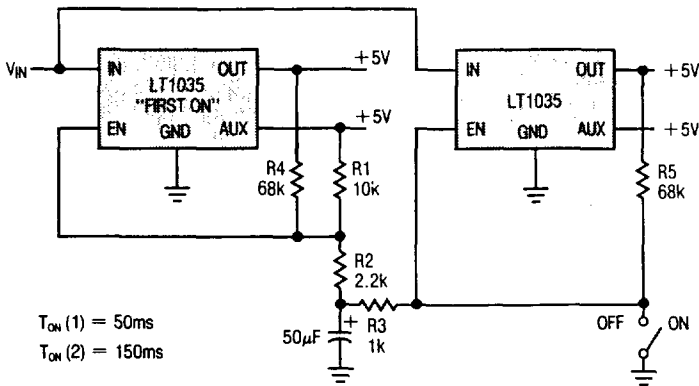

First-On, First-Off Sequencing

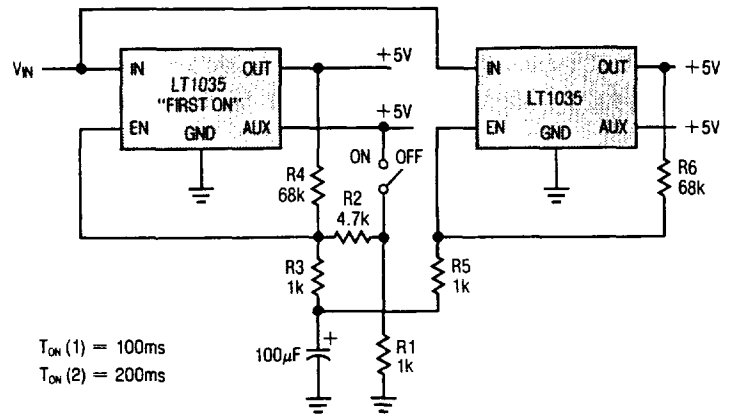

Power Supply Turn-On Sequencing

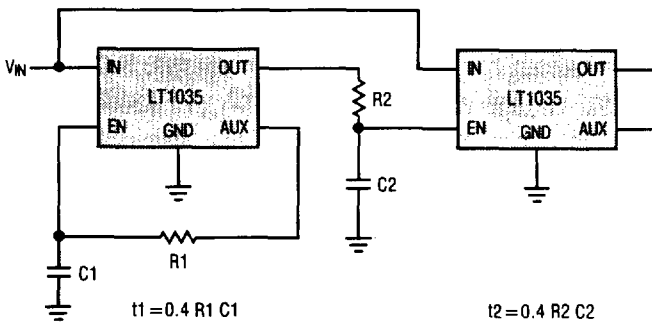

Fast Turn-Off, Delayed Turn-On

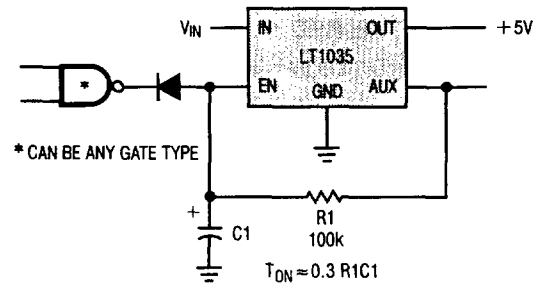

Thermal Cutoff at High Ambient Temperature

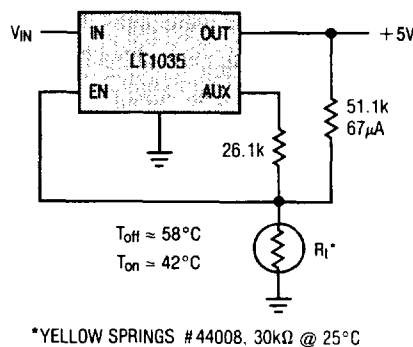

Latch-Off for $V_{OUT} \leq 4.7\text{V}$

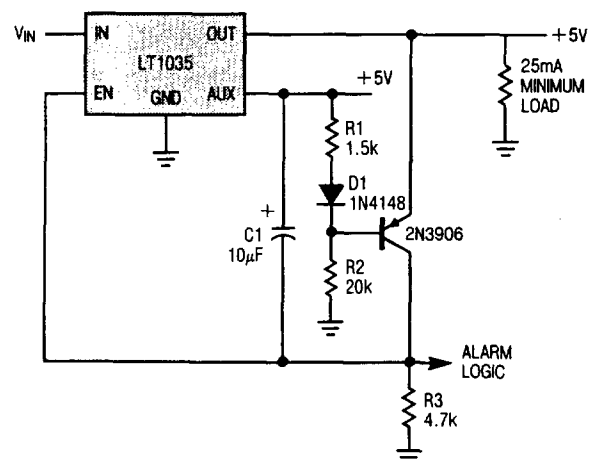

TYPICAL APPLICATIONS

Proportional Motor Speed Controller

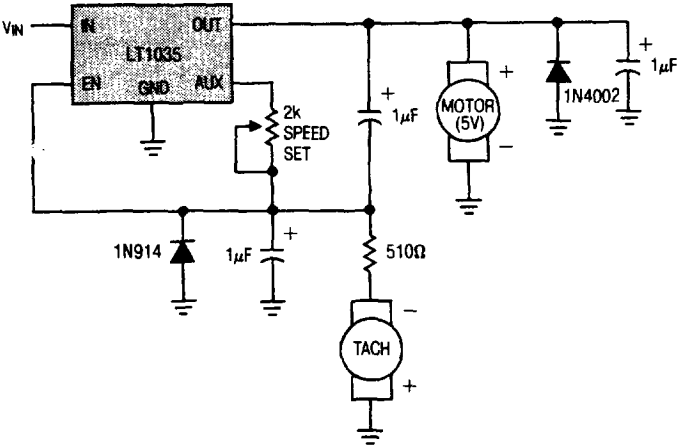

High Input Voltage Detection

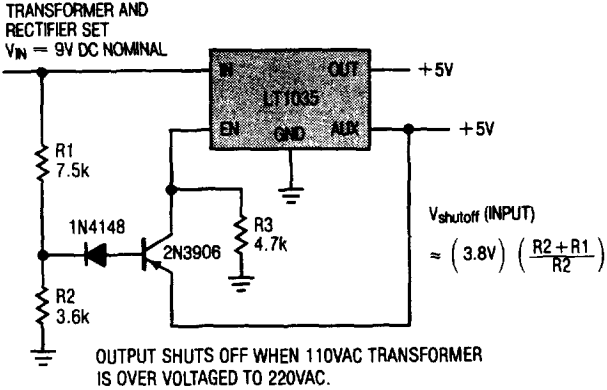

Opto-Coupled Output Control

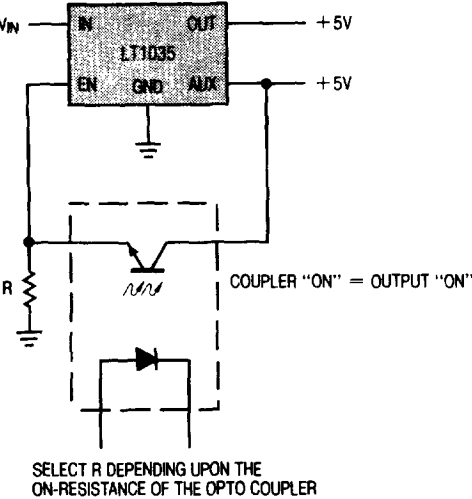

Push-On, Push-Off

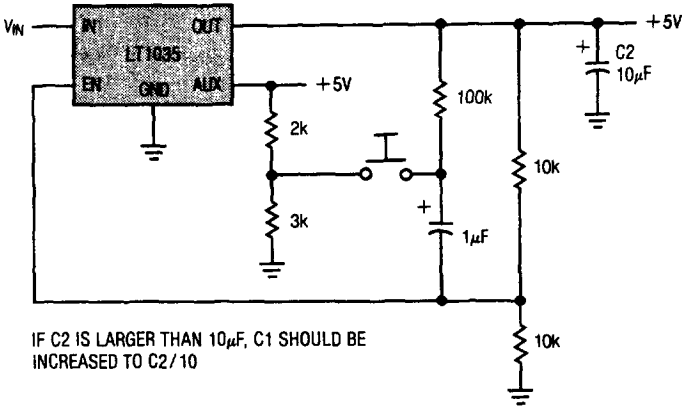

Latch-Off when Output Short

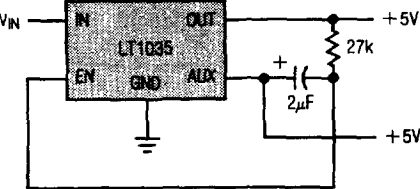

Delayed Power-Up

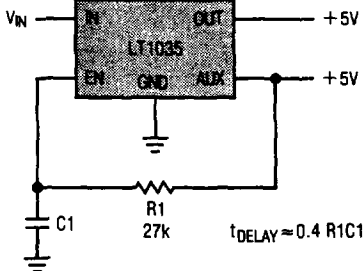

LT1035M/LT1035C

TYPICAL APPLICATIONS

Fast Electronic Circuit Breaker

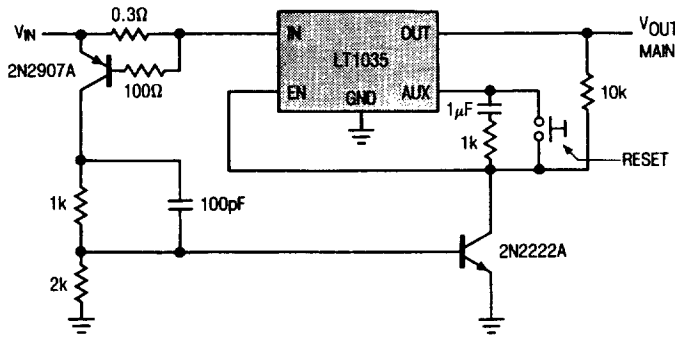

Battery Voltage Sensing Circuit

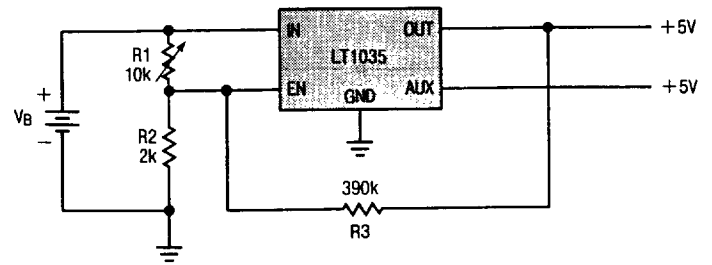

Memory Save on Power-Down

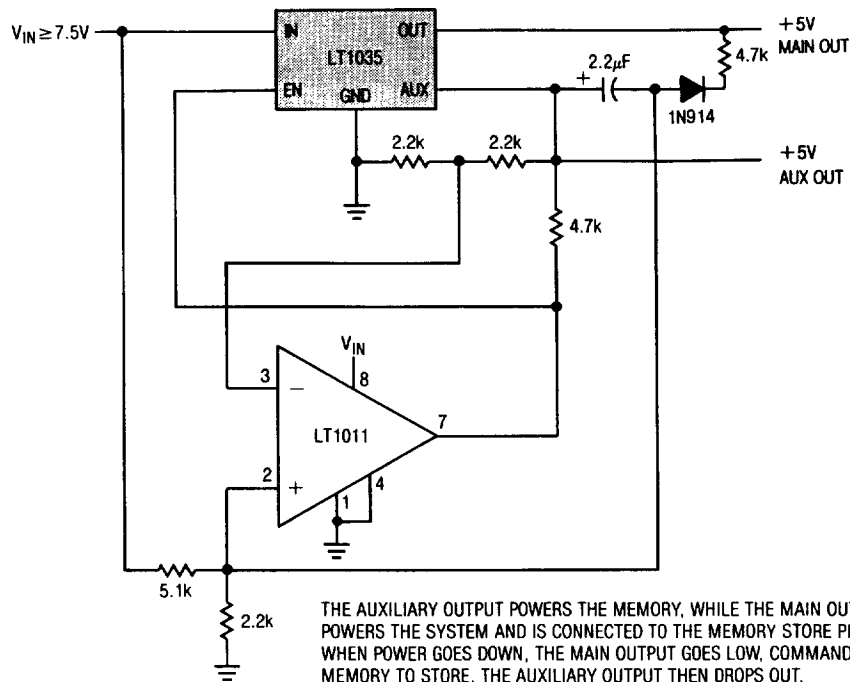

Line Dropout Detector

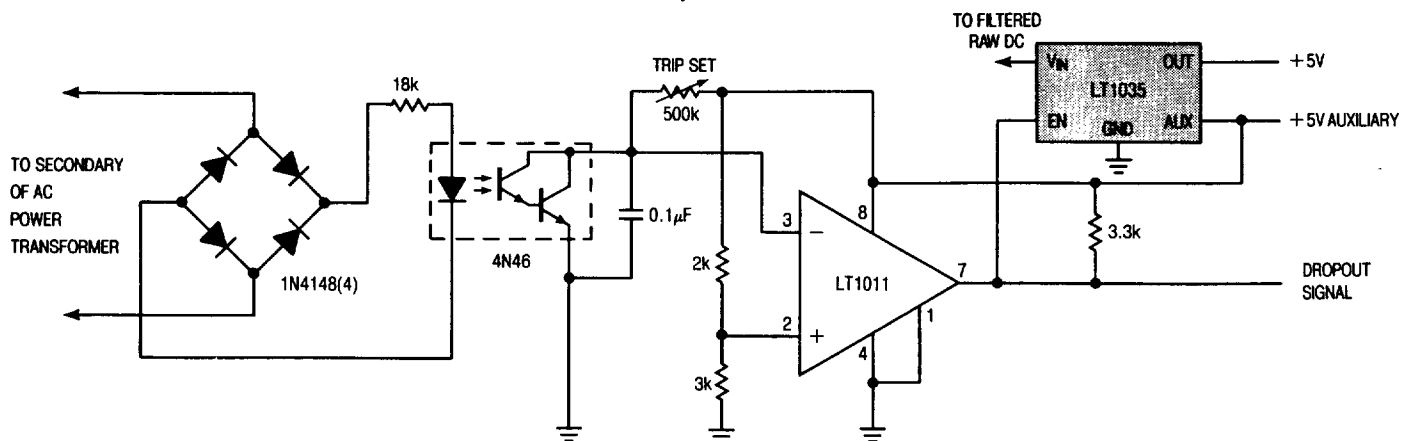

TYPICAL APPLICATIONS

Low Dissipation Regulator

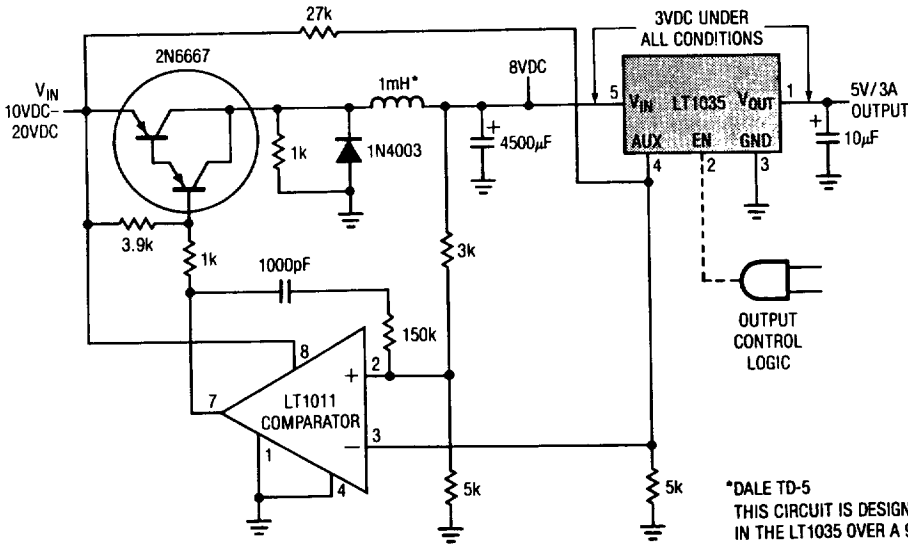

Regulator Losses at $I_{OUT} = 3A$

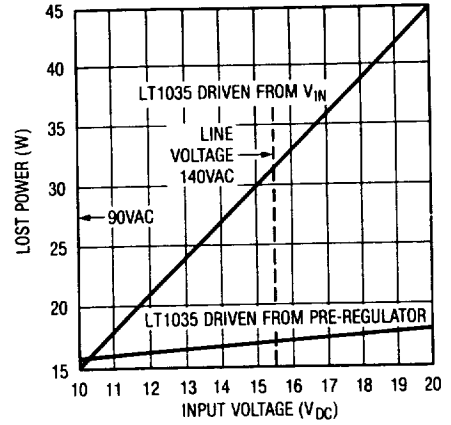

SCHEMATIC DIAGRAM

4

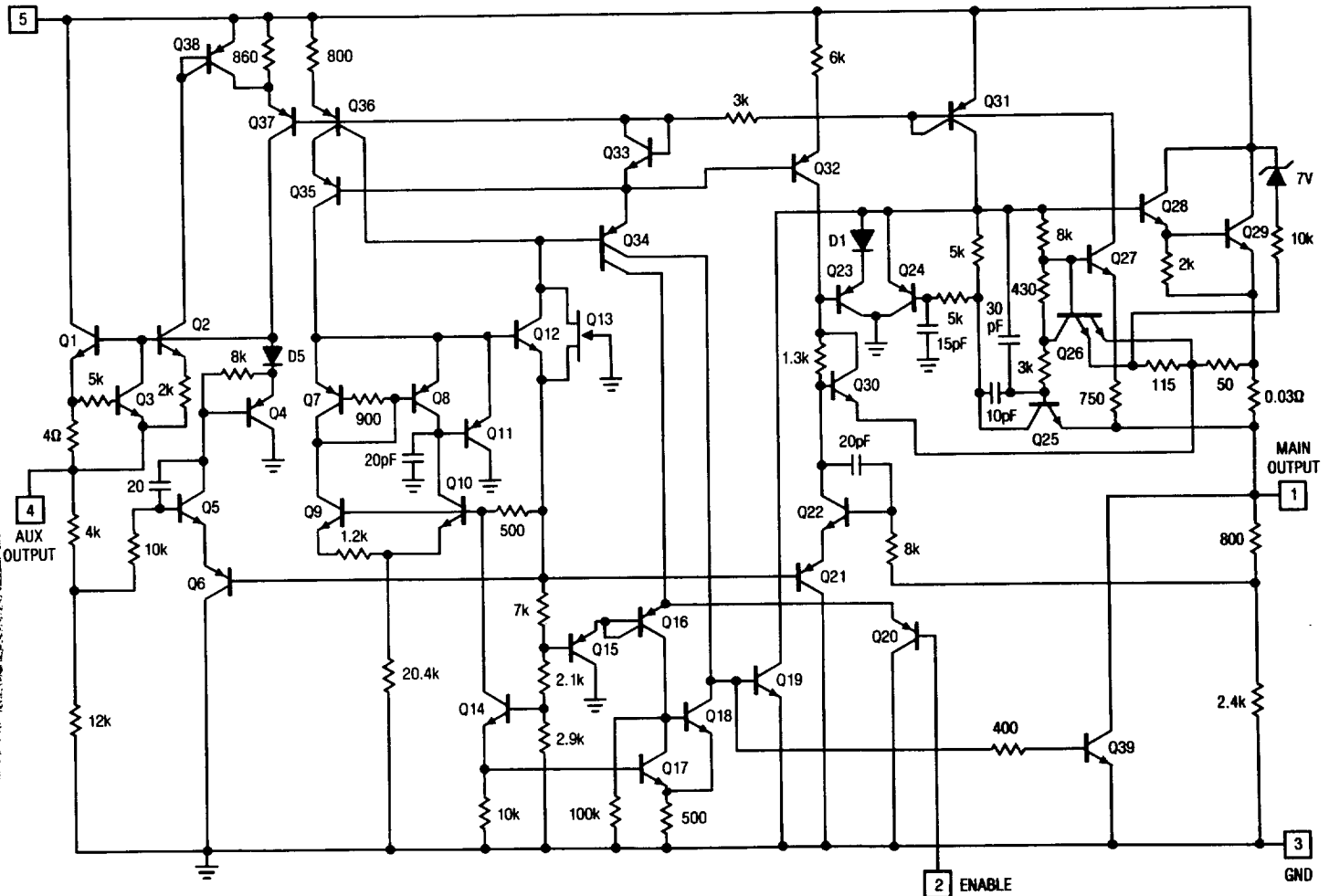

LT1035M/LT1035C

PACKAGE DESCRIPTION

TO-220 Package (5 Lead)

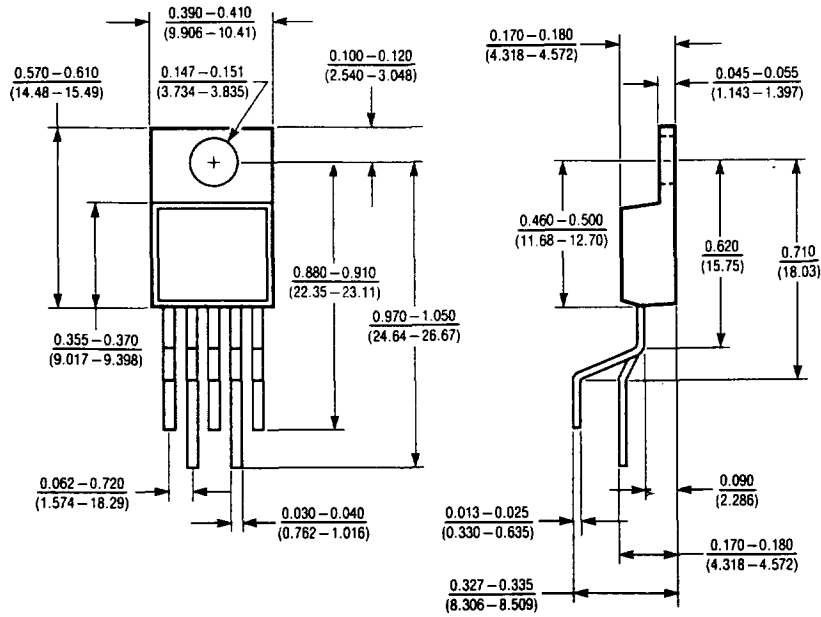

	T_{jMAX}	θ_{jC}
LT1035C	125°C	3°C/W

4-Pin Metal Package Similar to JEDEC TO-3

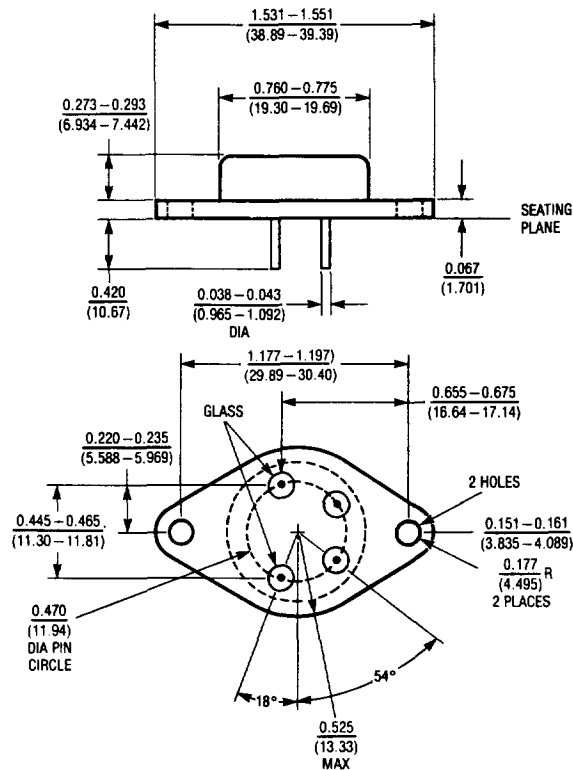

	T_{jMAX}	θ_{jC}
LT1035M	150°C	2.5°C/W
LT1035C	125°C	2.5°C/W