



TD13004D • TD13005D

Vishay Telefunken

Silicon NPN High Voltage Switching Transistor

Features

- Monolithic integrated C-E-free-wheel diode
- HIGH SPEED technology
- Planar passivation
- Very short switching times
- Very low switching losses
- Very low dynamic saturation
- Very low operating temperature
- High reverse voltage

Applications

Electronic lamp ballast circuits
Switch-mode power supplies

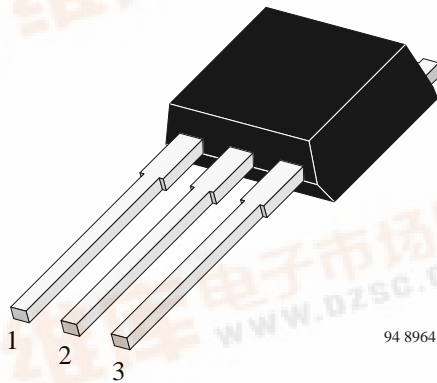

TD13004D • TD13005D 1 Base 2 Collector 3 Emitter

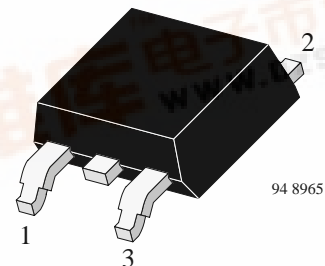

TD13004D • TD13005D –SMD 1 Base 2 Collector 3 Emitter

Absolute Maximum Ratings

$T_{case} = 25^{\circ}C$, unless otherwise specified

Parameter	Test Conditions	Type	Symbol	Value	Unit
Collector-emitter voltage		TD13004D	V_{CEO}	300	V
		TD13005D	V_{CEO}	400	V
		TD13004D	V_{CES}	600	V
		TD13005D	V_{CES}	700	V
Emitter-base voltage			V_{EBO}	9	V
Collector current			I_C	6	A
Collector peak current			I_{CM}	8	A
Base current			I_B	2	A
Base peak current			I_{BM}	4	A
Total power dissipation	$T_{case} \leq 60^{\circ}C$		P_{tot}	30	W
Junction temperature			T_j	150	$^{\circ}C$
Storage temperature range			T_{stg}	-65 to +150	$^{\circ}C$

TD13004D • TD13005D



Vishay Telefunken

Maximum Thermal Resistance

$T_{\text{case}} = 25^{\circ}\text{C}$, unless otherwise specified

Parameter	Test Conditions	Symbol	Value	Unit
Junction case		R_{thJC}	3	K/W

Electrical Characteristics

$T_{\text{case}} = 25^{\circ}\text{C}$, unless otherwise specified

Parameter	Test Conditions	Type	Symbol	Min	Typ	Max	Unit
Transistor							
Collector cut-off current	$V_{\text{CE}} = 600 \text{ V}$	TD13004D	I_{CES}			50	μA
	$V_{\text{CE}} = 700 \text{ V}$	TD13005D	I_{CES}			50	μA
	$V_{\text{CE}} = 600 \text{ V}; T_{\text{case}} = 150^{\circ}\text{C}$	TD13004D	I_{CES}			0.5	mA
	$V_{\text{CE}} = 700 \text{ V}; T_{\text{case}} = 150^{\circ}\text{C}$	TD13005D	I_{CES}			0.5	mA
Collector-emitter breakdown voltage (figure 1)	$I_{\text{C}} = 300 \text{ mA}; L = 125 \text{ mH}; I_{\text{measure}} = 100 \text{ mA}$	TD13004D	$V_{(\text{BR})\text{CEO}}$	300			V
		TD13005D	$V_{(\text{BR})\text{CEO}}$	400			V
Emitter-base breakdown voltage	$I_{\text{E}} = 1 \text{ mA}$		$V_{(\text{BR})\text{EBO}}$	9			V
Collector-emitter saturation voltage	$I_{\text{C}} = 2 \text{ A}; I_{\text{B}} = 0.5 \text{ A}$		V_{CEsat}			0.6	V
Base-emitter saturation voltage	$I_{\text{C}} = 2 \text{ A}; I_{\text{B}} = 0.5 \text{ A}$		V_{BEsat}			1.6	V
DC forward current transfer ratio	$V_{\text{CE}} = 5 \text{ V}; I_{\text{C}} = 10 \text{ mA}$		h_{FE}	10			
	$V_{\text{CE}} = 5 \text{ V}; I_{\text{C}} = 1 \text{ A}$		h_{FE}	10			
	$V_{\text{CE}} = 5 \text{ V}; I_{\text{C}} = 4 \text{ A}$		h_{FE}	4			
Dynamic saturation voltage	$I_{\text{C}} = 2 \text{ A}; I_{\text{B}} = 0.4 \text{ A}; t = 1 \mu\text{s}$		V_{CEsatdyn}		3		V
	$I_{\text{C}} = 2 \text{ A}; I_{\text{B}} = 0.4 \text{ A}; t = 3 \mu\text{s}$		V_{CEsatdyn}		1		V
Gain bandwidth product	$V_{\text{CE}} = 10 \text{ V}; I_{\text{C}} = 500 \text{ mA}; f = 1 \text{ MHz}$		f_{T}	4			MHz
Free-wheel diode							
Forward voltage	$I_{\text{F}} = 2 \text{ A}$		V_{F}		1.3	1.5	V
Turn-on transient peak voltage	$I_{\text{F}} = 2.5 \text{ A}; di_{\text{F}}/dt = 10 \text{ A}/\mu\text{s}$		V_{FP}		4	5	V
Reverse recovery current	$I_{\text{F}} = 2.5 \text{ A}; -di_{\text{F}}/dt = 5 \text{ A}/\mu\text{s}; V_{\text{S}} = 200 \text{ V}$		I_{RM}		5		A



Switching Characteristics

$T_{case} = 25^{\circ}C$, unless otherwise specified

Parameter	Test Conditions	Type	Symbol	Min	Typ	Max	Unit
Resistive load (figure 3)							
Turn on time	$I_C = 2\text{ A}; I_{B1} = -I_{B2} = 0.4\text{ A};$ $V_S = 125\text{ V}$		t_{on}		0.25	0.4	μs
Storage time			t_s		1.5	2.5	μs
Fall time			t_f		0.15	0.3	μs
Inductive load (figure 4)							
Storage time	$I_C = 2\text{ A}; I_{B1} = 0.4\text{ A};$ $L = 200\text{ }\mu H; V_{clamp} = 300\text{ V};$ $-V_{BE} = 5\text{ V}; T_{case} = 100^{\circ}C$		t_s		1.2	2	μs
Cross over time			t_c		0.4	0.7	μs
Free-wheel diode							
Reverse recovery time	$I_F = 0.5\text{ A}; I_R = 1\text{ A}; i_R = 0.25\text{ A}$		t_{rr}		0.7	1	μs
Forward recovery time	$I_F = 2\text{ A}; di_F/dt = 10\text{ A}/\mu s$		t_{fr}		0.4		μs
Reverse recovery time	$I_F = 2\text{ A}; -di_F/dt = 5\text{ A}/\mu s$		t_{rr}		1.1		μs
	$I_F = 2\text{ A}; -di_F/dt = 5\text{ A}/\mu s$		t_{IRM}		0.9		μs

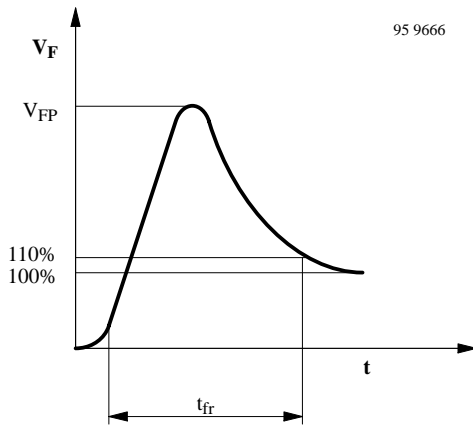

Figure 1. Turn on transient peak voltage

94 8863

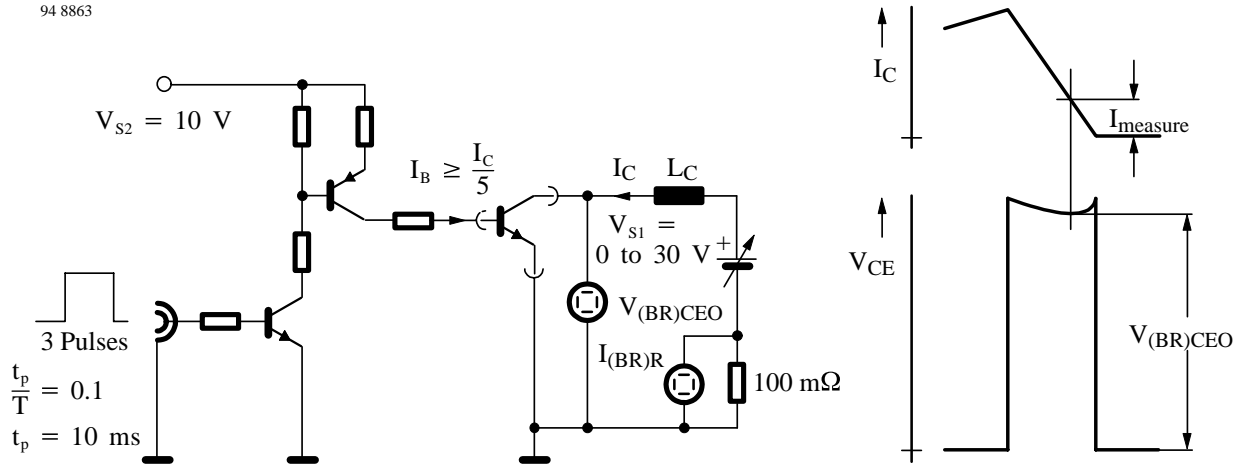
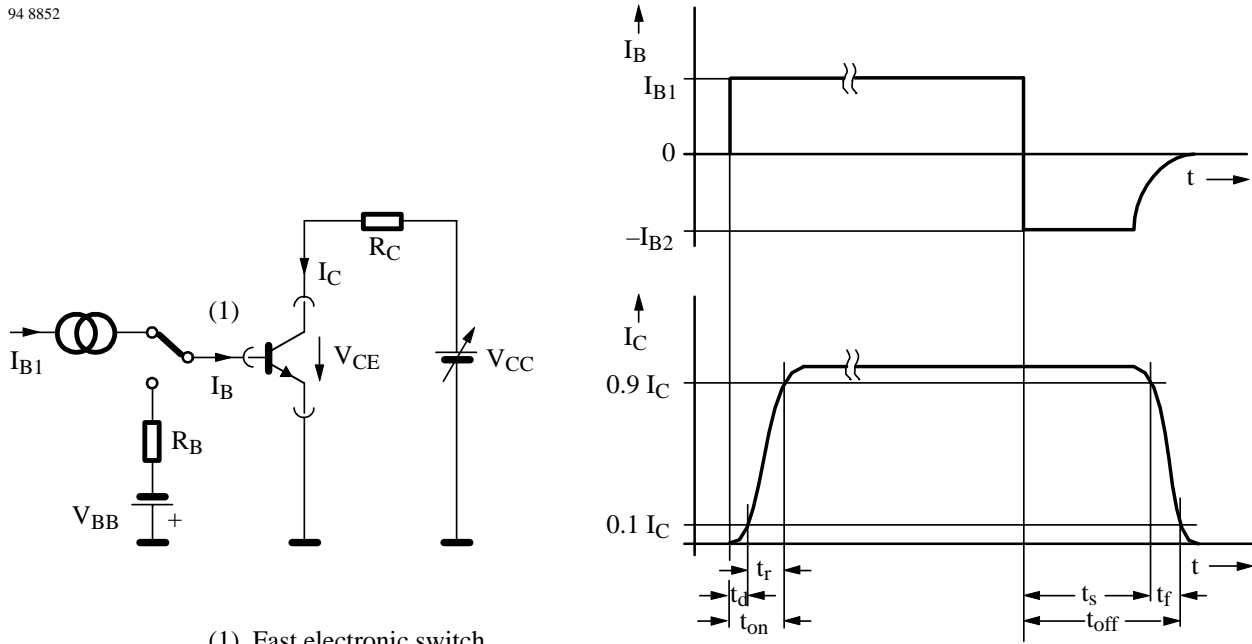

Figure 2. Test circuit for $V_{(BR)CEO}$

94 8852



(1) Fast electronic switch

Figure 3. Test circuit for switching characteristics – resistive load

94 8853

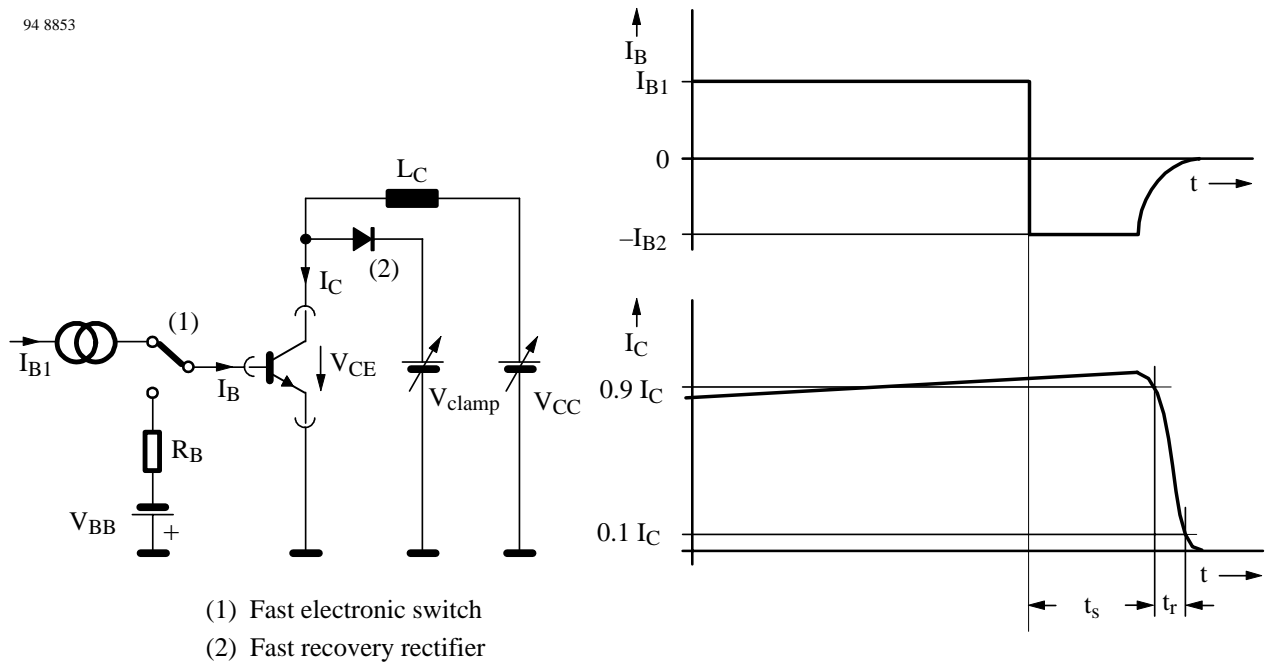
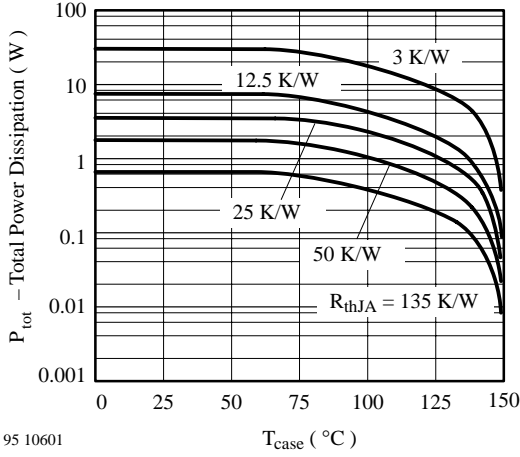

Figure 4. Test circuit for switching characteristics – inductive load

Typical Characteristics ($T_{case} = 25_C$ unless otherwise specified)



95 10601

Figure 5. P_{tot} vs. T_{case}

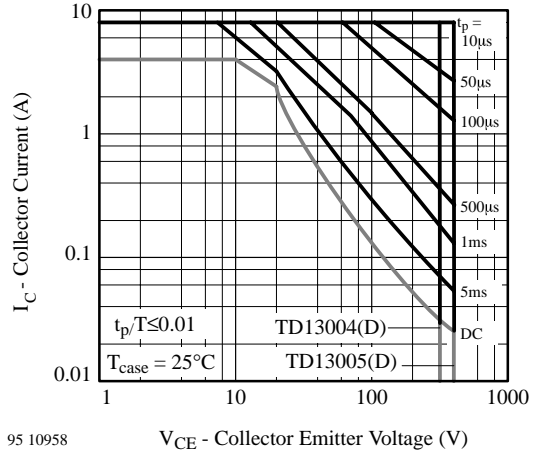

95 10958

Figure 8. I_C vs. V_{CE}

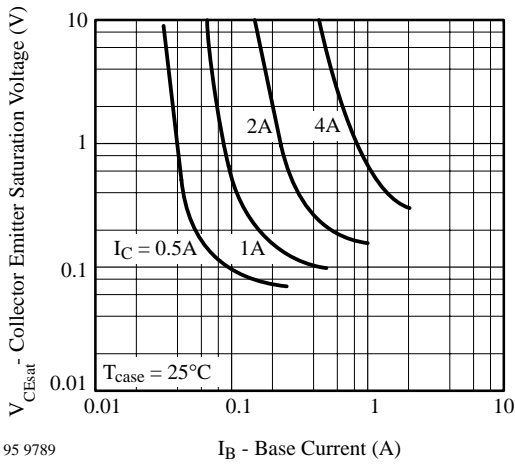

95 9789

Figure 6. $V_{CE(sat)}$ vs. I_B

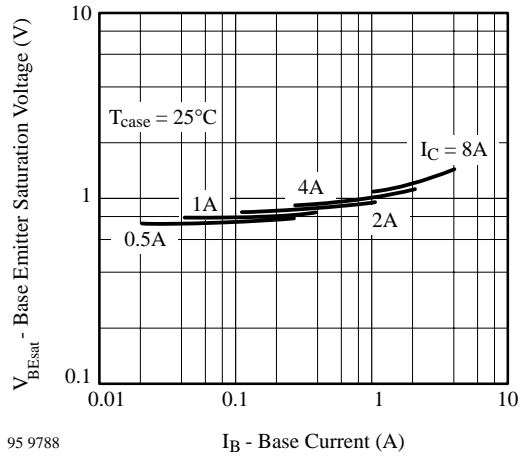

95 9788

Figure 9. $V_{BE(sat)}$ vs. I_B

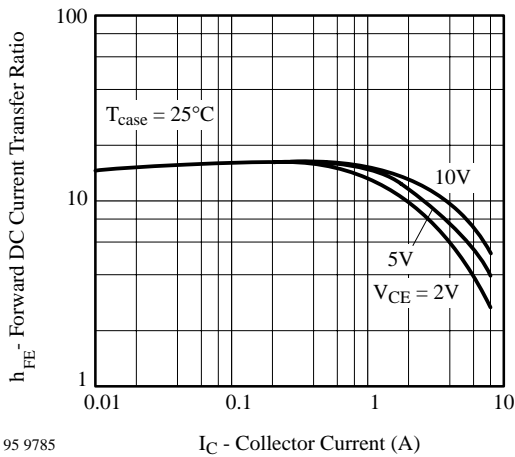

95 9785

Figure 7. h_{FE} vs. I_C

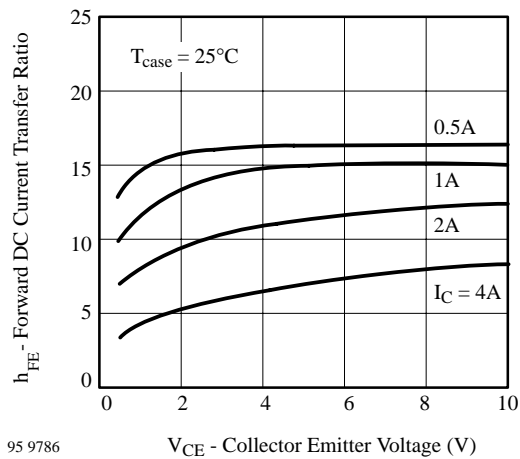

95 9786

Figure 10. h_{FE} vs. V_{CE}

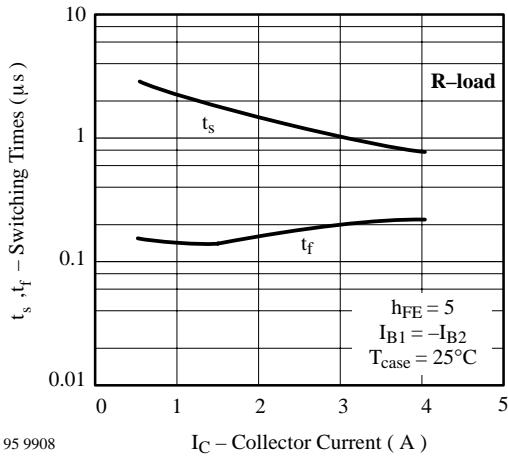

Figure 11. t_s, t_f vs. I_C

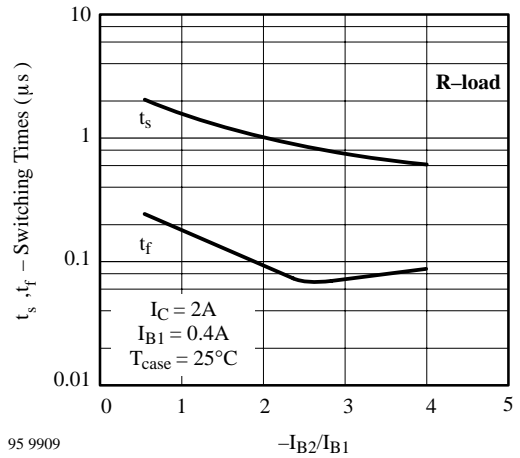

Figure 14. t_s, t_f vs. $-I_{B2}/I_{B1}$

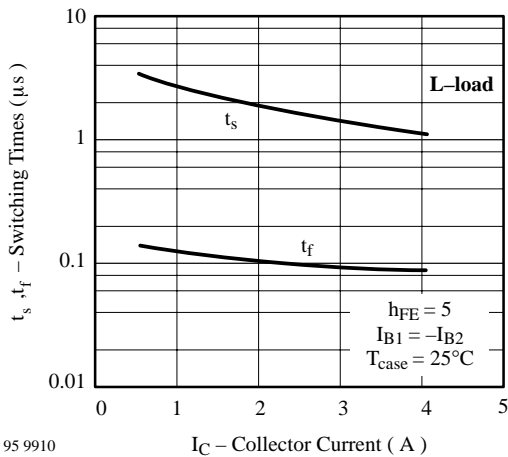

Figure 12. t_s, t_f vs. I_C

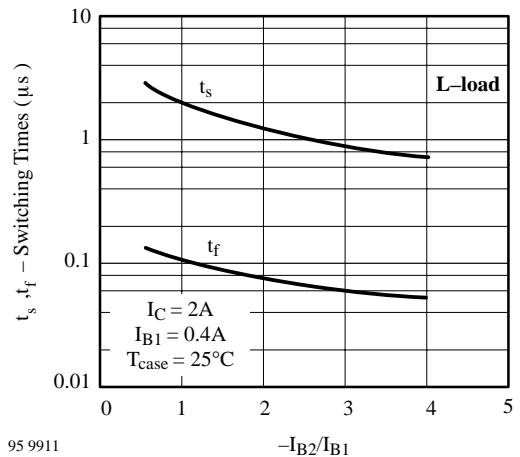

Figure 15. t_s, t_f vs. $-I_{B2}/I_{B1}$

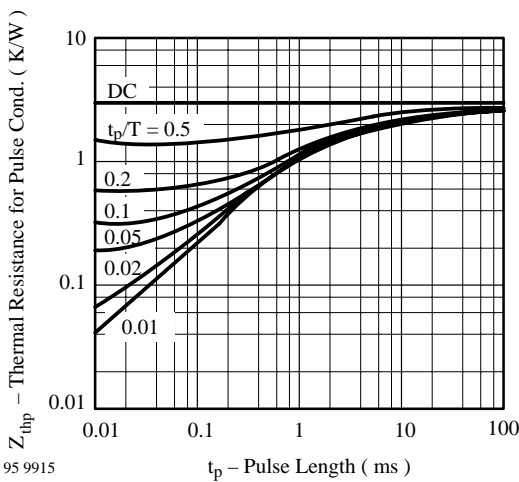

Figure 13. Z_{thp} vs. t_p

TD13004D • TD13005D

Vishay Telefunken



Dimensions in mm

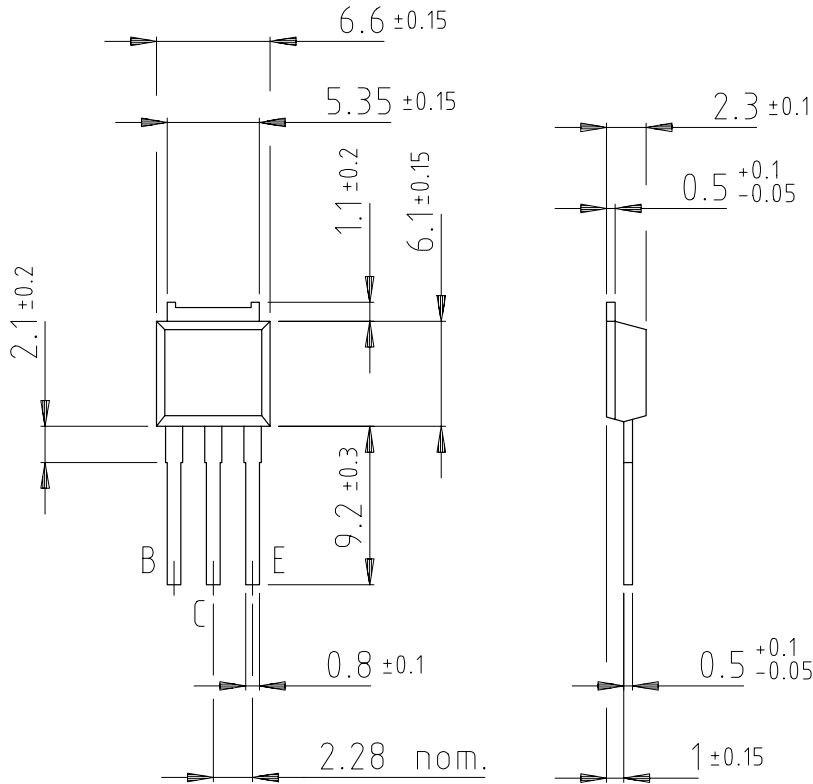

Plastic case JEDEC TO 251
Collector connected with metallic surface

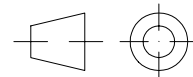

technical drawings
according to DIN
specifications

14292



TD13004D • TD13005D

Vishay Telefunken

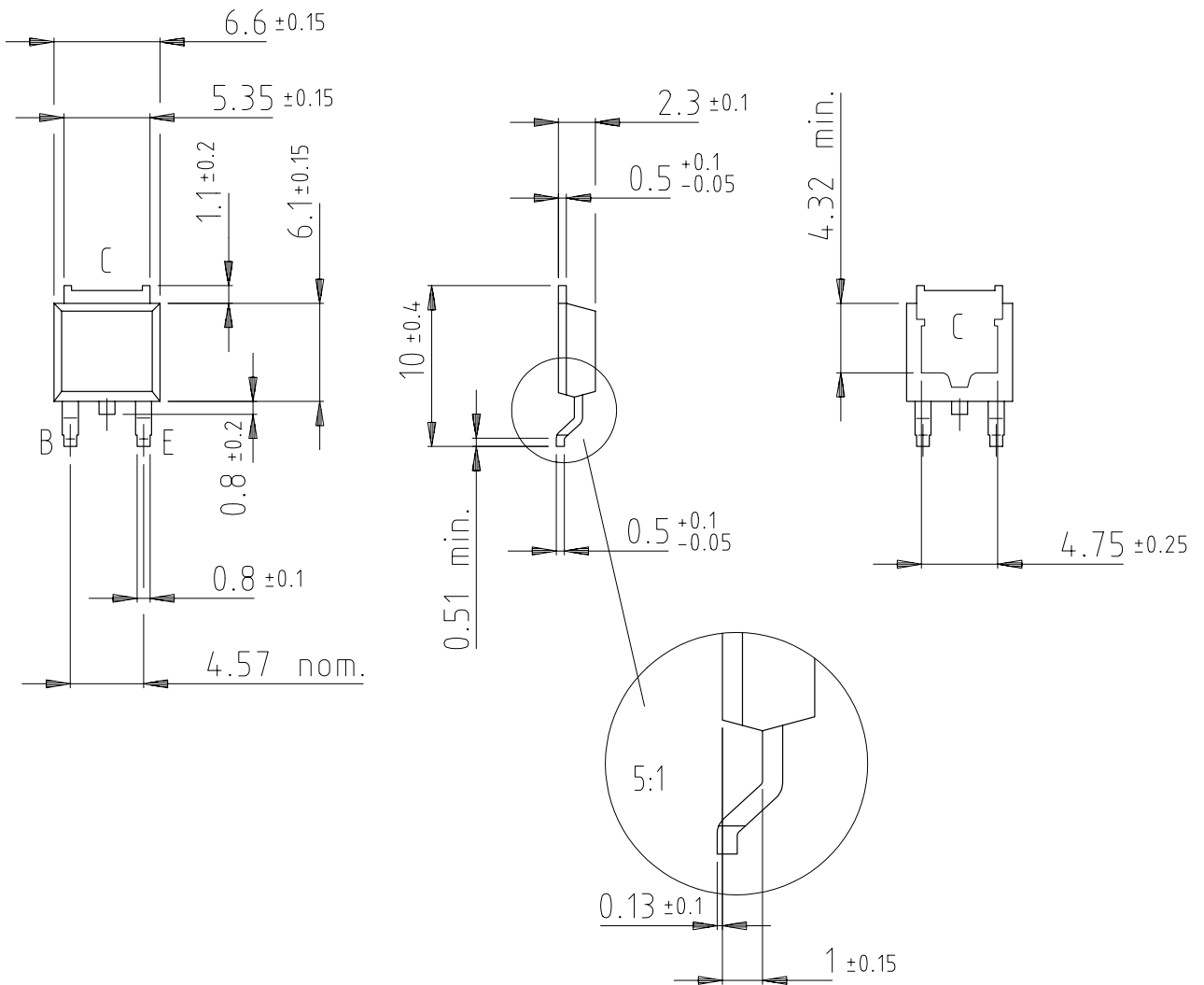

Plastic case JEDEC TO 252
Collector connected with metallic surface

14293

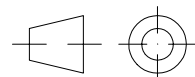

technical drawings
according to DIN
specifications

For ordering TO 252 add SMD to the type number (i.e. TD13004D • TD13005D –SMD)



Ozone Depleting Substances Policy Statement

It is the policy of **Vishay Semiconductor GmbH** to

1. Meet all present and future national and international statutory requirements.
2. Regularly and continuously improve the performance of our products, processes, distribution and operating systems with respect to their impact on the health and safety of our employees and the public, as well as their impact on the environment.

It is particular concern to control or eliminate releases of those substances into the atmosphere which are known as ozone depleting substances (ODSs).

The Montreal Protocol (1987) and its London Amendments (1990) intend to severely restrict the use of ODSs and forbid their use within the next ten years. Various national and international initiatives are pressing for an earlier ban on these substances.

Vishay Semiconductor GmbH has been able to use its policy of continuous improvements to eliminate the use of ODSs listed in the following documents.

1. Annex A, B and list of transitional substances of the Montreal Protocol and the London Amendments respectively
2. Class I and II ozone depleting substances in the Clean Air Act Amendments of 1990 by the Environmental Protection Agency (EPA) in the USA
3. Council Decision 88/540/EEC and 91/690/EEC Annex A, B and C (transitional substances) respectively.

Vishay Semiconductor GmbH can certify that our semiconductors are not manufactured with ozone depleting substances and do not contain such substances.

We reserve the right to make changes to improve technical design and may do so without further notice.

Parameters can vary in different applications. All operating parameters must be validated for each customer application by the customer. Should the buyer use Vishay-Telefunken products for any unintended or unauthorized application, the buyer shall indemnify Vishay-Telefunken against all claims, costs, damages, and expenses, arising out of, directly or indirectly, any claim of personal damage, injury or death associated with such unintended or unauthorized use.

Vishay Semiconductor GmbH, P.O.B. 3535, D-74025 Heilbronn, Germany
Telephone: 49 (0)7131 67 2831, Fax number: 49 (0)7131 67 2423