



PRELIMINARY

**MX9911**

**VIDEO CLOCK GENERATOR**

### FEATURES

- Clock generator for Video Graphic System
- Provide output frequency select pin
- Provide a select pin to select 14/5 or 17/5 times of input frequency
- Provide a TTL interface level output frequency which is input frequency divided by 4
- Provide a TTL interface level output frequency which is 14/5 or 17/5 times of input frequency
- 3.3 V power supply
- Package  
8-pin SOP (150mil)

### GENERAL DESCRIPTION

The product is a clock synthesizer chip for Video Graphic System. It uses advanced Phase lock loop technology to generate desired clock. The reference clock is supplied by external crystal. The crystal frequency is 4 x 3.579545 MHz in NTSC case, and is 4 x 4.43361875 MHz in PAL case. A select pin is provided to select 14/5 or 17/5 times of reference clock. Beside that, reference clock divided by four clock output (FSC) is also provided.

The product is 3.3 V operation, and the package type is 8-pin SOP.

### PIN CONFIGURATIONS

#### 8-PIN SOP

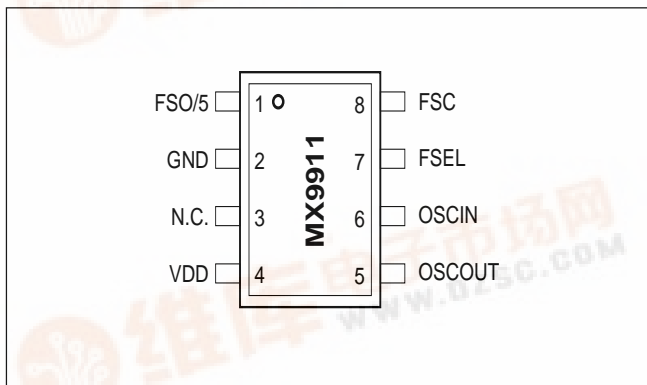

**PIN DESCRIPTION**

SYMBOL	PIN TYPE	PIN NUMBER	DESCRIPTION
FSO/5	O	1	Clock output. Crystal frequency times 17/5 or 14/5
GND		2	Ground
N.C.		3	No connection
VDD		4	Power supply
OSCOUT	O	5	Crystal pin
OSCIN	I	6	Crystal pin
FSEL	I	7	Frequency select pin(High:FSO/5=4*FSC*17/5, Low:FSO/5=4*FSC*14/5). Toggling of FSEL will reset the counter in the FEEDBACK DIVIDER.
FSC	O	8	Clock output. Crystal frequency divided by 4.

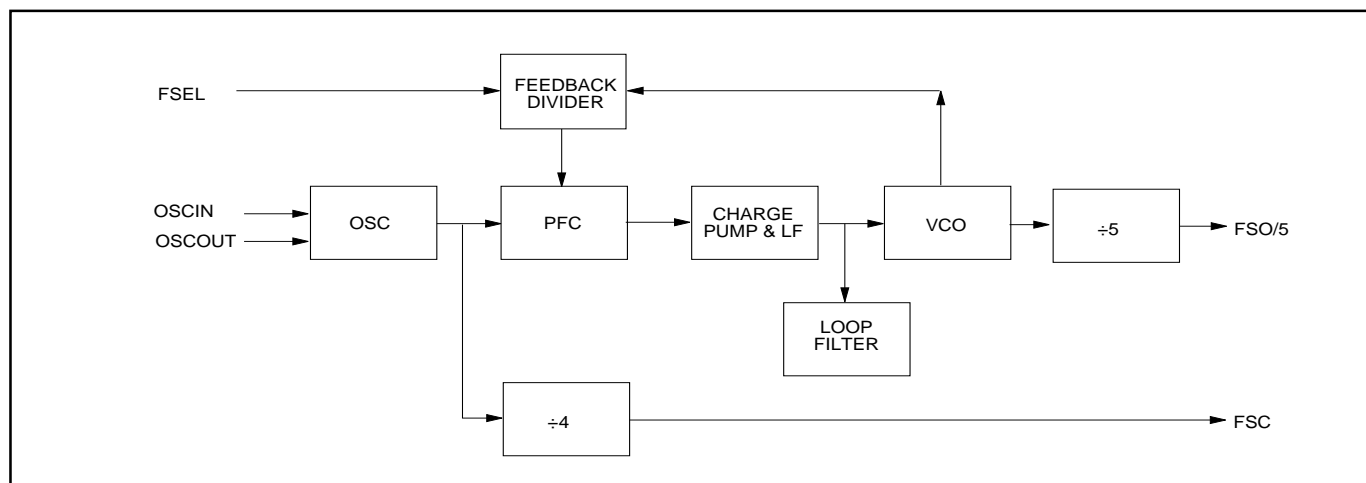
**BLOCK DIAGRAM**

**FUNCTIONAL DESCRIPTION**

The Video clock generator is an integrated circuit of phase locked loop frequency synthesizer. It provides two clock output frequencies. The first output frequency (FSC) is the crystal frequency divided by 4 clock. The second output frequency (FSO/5) is 14/5 or 17/5 times of crystal frequency. The FSO/5 output frequency can be selected by FSEL Pin. When FSEL pin is high, FSO/5 is 17/5 times of crystal frequency. When FSEL is low, FSO/5 is 14/5 times of crystal frequency.

As shown in the block diagram, a Phase locked loop consists of feedback divider, phase frequency comparator(PFC), Charge pump, voltage controlled oscillator(VCO), and loop filter. All components for PLL are integrated inside the chip.

Note: The counter in the FEEDBACK DIVIDER can be reset by toggling the FSEL after VDD exceed 3.0V. It takes 5ms for FSO to be stable after FSEL's toggling.

**FREQUENCY TABLE( in MHz)  
(in NTSC case)**

CRYSTAL	FSEL	FSC	FSO/5
4*3.579545	1	3.579545	4*3.579545*17/5
4*3.579545	0	3.579545	4*3.579545*14/5

**(in PAL case)**

CRYSTAL	FSEL	FSC	FSO/5
4*4.43361875	1	4.43361875	4*4.43361875*17/5
4*4.43361875	0	4.43361875	4*4.43361875*14/5



## ABSOLUTE MAXIMUM RATINGS

RATING	VALUE
Storage Temperature	-85°C to 150°C
Applied Input Voltage	-0.5V to VDD + 0.5V
Applied Output Voltage	-0.5V to VDD + 0.5V
Supply Voltage	-0.5V to 5V
Operating Temperature	0 to 80°C
Power Dissipation	0.5Watts

### NOTICE:

Stresses greater than those listed under ABSOLUTE MAXIMUM RATINGS may cause permanent damage to the device. This is a stress rating only and functional operation of the device at these or any other conditions above those indicated in the operational sections of this specification is not implied. Exposure to absolute maximum rating conditions for extended period may affect reliability.

### NOTICE:

Specifications contained within the following tables are subject to change.

## DC CHARACTERISTICS TA = 0°C to 80°C, VDD = 3.15V to 3.6V

SYMBOL	PARAMETER	MIN.	TYP.	MAX.	UNIT	CONDITIONS
VIL	Input Low Voltage			0.8	V	
VIH	Input High Voltage	2.4			V	
IIL	Input Low Current			-5	uA	
IIH	Input High Current			5	uA	
IVDD	VDD Current	20	30	40	mA	
VOL	Output Low Voltage			0.4	V	IOL=8mA, FSO/5 output
VOH	Output High Voltage	2.4			V	IOH=-4mA, FSO/5 output
CI	Input Capacitance			10	pF	
Ro (PMOS)	Output Resistance	175	350	525	Ohm	IOH=-600uA, FSC output
Ro (NMOS)	Output Resistance	85	175	260	Ohm	IOL=600uA, FSC output

## AC CHARACTERISTICS TA = 0°C to 80°C, VDD = 3.15V to 3.6V

SYMBOL	PARAMETER	MIN.	TYP.	MAX.	UNIT	CONDITIONS
Dt <sub>1</sub>	Duty Cycle	45		55	%	FSC
Dt <sub>2</sub>	Duty Cycle	55	59	62	%	FSO/5 for Rev.E, 30pF load
Tr/Tf	Rise/Fall Time	2	3.5	5	ns	FSO/5 output, 30 pF load
Tup	Power up Time		1	5	ms	1. After power is stable 2. FSO/5 frequency from 0 to 50MHz

## ORDERING INFORMATION

PART NO.	PACKAGE
MX9911MC	8-PIN SOP

## PACKAGE INFORMATION

8-PIN PLASTIC SOP (150 mil)

ITEM	MILLIMETER	INCHES
A	$4.90 \pm .05$	$.193 \pm .002$
B	$.60 \pm .10$	$.024 \pm .004$
C	1.27 [TP]	.050 [TP]
D	$.41 \pm .10$	$.016 \pm .004$
E	$.13 \pm .03$	$.005 \pm .001$
F	$1.60 \pm .13$	$.063 \pm .005$
G	$1.45 \pm .13$	$.057 \pm .005$
H	$5.99 \pm .3$	$.236 \pm .012$
I	$3.91 \pm .13$	$.154 \pm .005$
J	$1.02 \pm .13$	$.040 \pm .005$
K	.20	.008
L	$.60 \pm .10$	$.024 \pm .004$

**NOTE:** Each lead centerline is located within .25 mm [.01 inch] of its true position [TP] at maximum material condition.

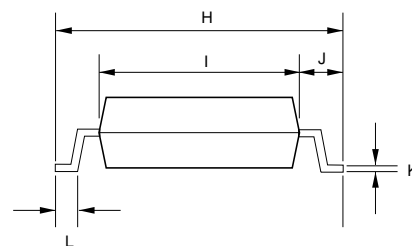
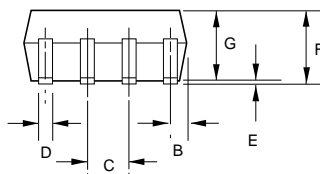
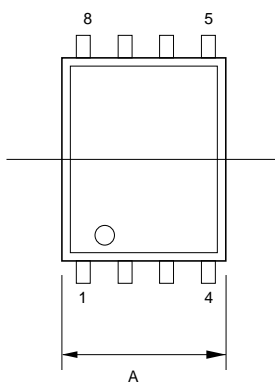



MX9911

---

---

## MACRONIX INTERNATIONAL CO., LTD

**HEADQUARTERS :**

TEL : +886-3-578-8888  
FAX : +886-3-578-8887

**EUROPE OFFICE :**

TEL : +32-2-456-8020  
FAX : +32-2-456-8021

**JAPAN OFFICE :**

TEL : +81-44-246-9100  
FAX : +81-44-246-9105

**SINGAPORE OFFICE :**

TEL : +65-747-2309  
FAX : +65-748-4090

**TAIPEI OFFICE :**

TEL : +886-2-2509-3300  
FAX : +886-2-2509-2200

**MACRONIX AMERICA INC.**

TEL : +1-408-453-8088  
FAX : +1-408-453-8488

**CHICAGO OFFICE :**

TEL : +1-847-963-1900  
FAX : +1-847-963-1909

**[http : //www.macronix.com](http://www.macronix.com)**

---