

DALLAS SEMICONDUCTOR

DS1207 TimeKey

FEATURES

- Cannot be deciphered by reverse engineering
- Time allotment from one day to 512 days for trial periods, rentals, and leasing
- Partitioned memory thwarts pirating
- User-insertable packaging allows personal possession
- Exclusive blank keys on request
- Appropriate identification can be made with a 64-bit reprogrammable memory
- Unreadable 64-bit match code virtually prevents discovery by exhaustive search with over 10^{19} possibilities
- Random data generation on incorrect match codes obscures real accesses
- 384 bits of secure read/write memory create additional barriers by permitting data changes as often as needed
- Rapid erasure of identification, security match code and secure read/write memory can occur if tampering is detected
- Durable and rugged
- Applications include software authorization, gray market software protection, proprietary data, financial transactions, secure personnel areas, and system access control

DESCRIPTION

The DS1207 TimeKey is a miniature security system that stores 64 bits of user-definable identification code and a 64-bit security match code that protects 384 bits of read/write nonvolatile memory. The 64-bit identification code and the security match code are programmed into the TimeKey via a special program mode operation. After programming, the TimeKey follows a procedure with a serial format to retrieve or update data. The TimeKey is set to expire from one day to 512 days or infinity, as

PIN ASSIGNMENT

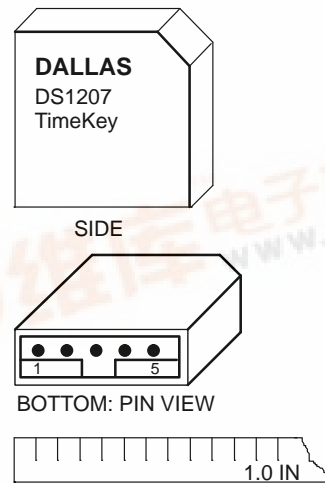

See Mech. Drawings Section

PIN DESCRIPTION

Pin 1	NC	No connection
Pin 2	$\overline{\text{RST}}$	Reset
Pin 3	DQ	Data input/output
Pin 4	CLK	Clock
Pin 5	GND	Ground

specified by the customer. The TimeKey starts its count-down from the first access by the end user.

Interface cost to a microprocessor is minimized by on-chip circuitry that permits data transfer with only three signals: Clock (CLK), Reset ($\overline{\text{RST}}$) and Data Input/Output (DQ). Low pin count and a guided entry for a mating receptacle overcome mechanical problems normally encountered with conventional integrated circuit packaging, making the device transportable and user-insertable.

OPERATION – NORMAL MODE

The TimeKey has two modes of operation: normal and program. The normal mode of operation provides the functions of reading and writing the 384-bit secure memory. The block diagram (Figure 1) illustrates the main elements of the TimeKey when used in the normal mode. To initiate data transfer with the TimeKey, \overline{RST} is taken high and 24 bits are loaded into the command register on each low-to-high transition of the CLK input. The command register must match the exact bit pattern which defines normal operations with a function code of read or write. If one of these patterns is not matched, communications are ignored. If the command register is loaded properly, communications are allowed to continue. Data is clocked out of the TimeKey on the high-to-low transition of the clock. If the pattern matched in the command register calls for a normal read or write, the next 64 cycles following the command word are read and data is clocked out of the identification memory. The next 64 write cycles are written to the compare register (Figure 2). These 64 bits must match the exact pattern stored in the security match memory. If a match is not found, access to additional information is denied. Instead, if a normal read mode is selected, random garbled data is output for the next 384 cycles. If a normal write cycle is selected and a match is not achieved, the TimeKey will ignore any additional information. However, when a security match is achieved, access is permitted to write the 384-bit secure memory.

OPERATION - PROGRAM MODE

The program mode of operation provides the functions of programming the identification and security match memory, and setting and reading the amount of time the TimeKey can be used. The block diagram in Figure 3 illustrates the main elements of the TimeKey when used in the program mode. To initiate the program mode, \overline{RST} is driven high and 24 bits are loaded into the command register on each low-to-high transition of the CLK input. The command register must match the exact bit pattern that defines the program mode for the identification and security match bits or the program mode for setting and reading the amount of time for which the TimeKey can be used. If an exact match for one of the seven function codes of the program mode is not found, the remainder of the program mode is ignored. When the command register is properly loaded for programming the identification and security match bits, the next 128 bits are written to the identification and security match memory (Figure 4). When this mode of operation is invoked, all memory contents are erased.

SETTING AND READING TIME REMAINING

There are six functions of the program mode which are used to set or read the amount of time for which the TimeKey will allow full operation. To initiate any of the six functions of the program mode used for setting and reading time remaining, \overline{RST} is driven high and 24 bits are loaded into the command register on each low-to-high transition of the CLK input. If the command register is properly loaded with the function code for reading the 20-bit day clock counter, the next 20 bits will be output (LSB first) as a binary count of the amount of time elapsed in the current day (see Figure 5). The time can be calculated by dividing this count reading by 2^{20} (20 bits is equal to 1,048,576 counts). One minus this result is the fraction of a day remaining. The 20-bit day clock counter is driven by an internal oscillator that has a period of 82.4 ms. If the command register is properly loaded with the function code for reading the 9-bit number of days counter, the next 9 bits will be output (LSB first) as a binary count of the days remaining (see Figure 6). This count is decremented each time the day clock counter rolls over to zero. When the number of days remaining counter rolls through zero, normal and program mode write cycles are inhibited. If the program mode read cycle to the number of days counter is attempted, the nine bits will be returned as all ones.

If the command register is properly loaded with the function code for writing the 9-bit number of days counter, the next nine bits will be input (LSB first) as a binary count of the desired number of days in which the TimeKey will be fully functional (see Figure 7). The number of days counter can be changed by writing over an entered value as often as required until the lock command is entered. The lock command is given when the command register is properly loaded with the function code for locking up the number of days counter. The lock command consists of the 24-bit command word only (see Figure 8). Once the lock command is given, all future write cycles to the number of days register are ignored. After the correct value has been written and locked into the number of days counter, the DS1207 will start counting the time from the entered value to zero after the first access to the TimeKey is executed, provided the arm oscillator bit is set. The arm oscillator bit is set when the command register has been properly loaded with the function code for arming the oscillator. The arm oscillator command consists of the 24-bit command word only (see Figure 9). One other command is also available for use in setting and reading time remaining. A stop oscillator command is given when the command register is

properly loaded with the function code for stopping the oscillator. The stop oscillator command consists of the 24-bit command word only (see Figure 10). This command will only execute prior to issuing a lock command. After the lock command is issued, stop oscillator commands are ignored.

A sequence for properly setting the expiration time of the DS1207 is as follows (see Figure 11). First, program the identification and security match bits to the desired value. Use normal mode operation to write the appropriate secure data. Second, write the number days remaining register to the desired value. This number can be immediately verified by reading the number of days remaining. Next, arm the oscillator by writing the appropriate command. Then do a normal mode read. This action will start the internal oscillator. Now read the 20-bit day clock counter several times to verify that the oscillator is running. After oscillator activity has been verified, issue the stop oscillator command. The lock command should be issued, followed by the arm oscillator command. The TimeKey will start the countdown to expiration on the next access. To guarantee security, a locked TimeKey cannot be unlocked. The key cannot be reprogrammed after expiration. The oscillator verification portion of this sequence is not required and can be deleted when speed in setting time remaining is important.

COMMAND WORD

Each data transfer for normal and program mode begins with a 3-byte command word as shown in Figure 12. As defined, the first byte of the command word specifies the function code. Eight function codes are acceptable (Figure 13). If any one of the bits of the first byte of the command word fails to meet one of the exact patterns for function codes, the data transfer will be aborted.

The first two bits of the second byte of the command word specify whether the data transfer to follow is program or normal mode. The bit pattern for program mode is 0 in bit 0 and 1 in bit 1. The bit pattern for normal mode is a 1 in bit 0 and a 0 in bit 1. The other two possible combinations for the first two bits of byte 2 will cause the transfer to abort. The program mode can be invoked with one of seven function codes: program identification and security match, read the 20-bit day clock counter, read the number of days count, write the number of days

count, lock number of days count, arm oscillator, and stop oscillator.

The remaining six bits of byte 2 and the first four bits of byte 3 must be written to match one of the five patterns as indicated in Figure 12 or data transfer will abort. Under special contract with Dallas Semiconductor, these bits can be defined by the user as any bit pattern other than those specified as unavailable. The bit pattern as defined by the user must be written exactly or data transfer will abort. The last four bits of byte 3 of the command word must be written 1011 or data transfer will abort. Table 1 provides a summary of the command words in hexadecimal as they apply to all function codes for both program mode and normal mode.

RESET AND CLOCK CONTROL

All data transfers are initiated by driving the \overline{RST} input high. The reset input serves three functions. First, it turns on control logic which allows access to the command register for the command sequence. Second, the \overline{RST} signal provides a power source for the cycle to follow. To meet this requirement, a drive source for \overline{RST} of 2 mA at 3.5 volts is required. Third, the \overline{RST} signal provides a method of terminating data transfer.

A clock cycle is a sequence of a falling edge followed by a rising edge. For data inputs, the data must be valid during the rising edge of the clock cycle. Command bits and data bits are input on the rising edge of the clock. Data bits are output on the falling edge of the clock. The rising edge of the clock returns the DQ pin to a high impedance state. All data transfer terminates if the \overline{RST} pin is low and the DQ pin goes to a high impedance state. Data transfer is illustrated in Figure 14 for normal mode and Figure 15 for program mode.

TIMEKEY CONNECTIONS

The TimeKey is designed to be plugged into a standard 5-pin 0.1 inch center SIP receptacle. A guide is provided to prevent the TimeKey from being plugged in backwards and aid in alignment of the receptacle. For portable applications, contact to the TimeKey pins can be determined to ensure connection integrity before data transfer begins. CLK, \overline{RST} , and DQ all have 20K ohm pulldown resistors to ground that can be sensed by a reading device.

COMMAND WORDS Table 1

Summary of the command words in hexadecimal as they apply to all function codes for both program mode and normal mode for the DS1207-G01 only. (See Figure 12 and Figure 13 for detailed command words.)

MODE	FUNCTION	COMMAND WORDS		
		MSB		LSB
NORMAL	READ	B0	01	62
NORMAL	WRITE	B0	01	9D
PROGRAM	WRITE	B0	02	9D
PROGRAM	READ DAY CLOCK COUNTER	B0	02	F1
PROGRAM	READ DAYS REMAINING	B0	02	F3
PROGRAM	WRITE DAYS REMAINING	B0	02	F2
PROGRAM	ARM OSCILLATOR	B0	02	F5
PROGRAM	LOCK NUMBER OF DAYS COUNT	B0	02	F6
PROGRAM	STOP OSCILLATOR	B0	02	F4

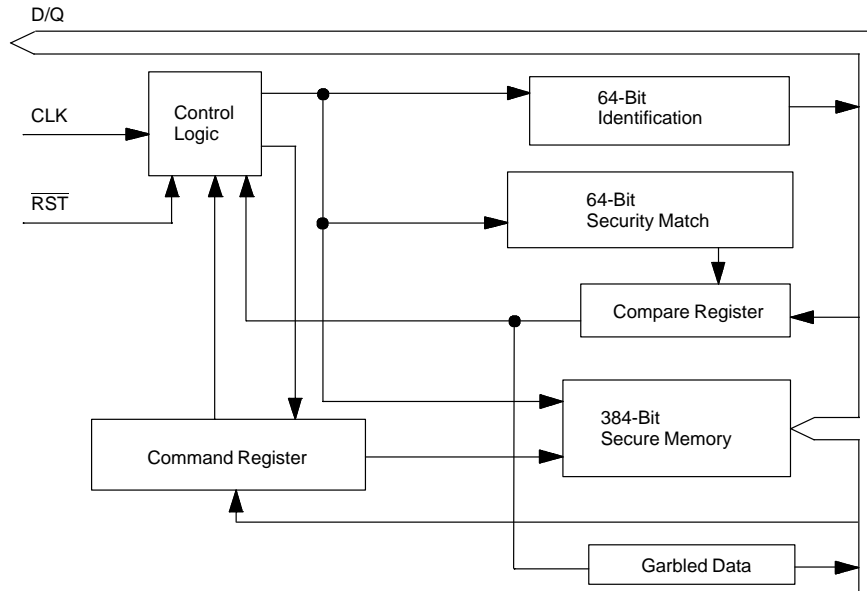
BLOCK DIAGRAM: NORMAL MODE Figure 1

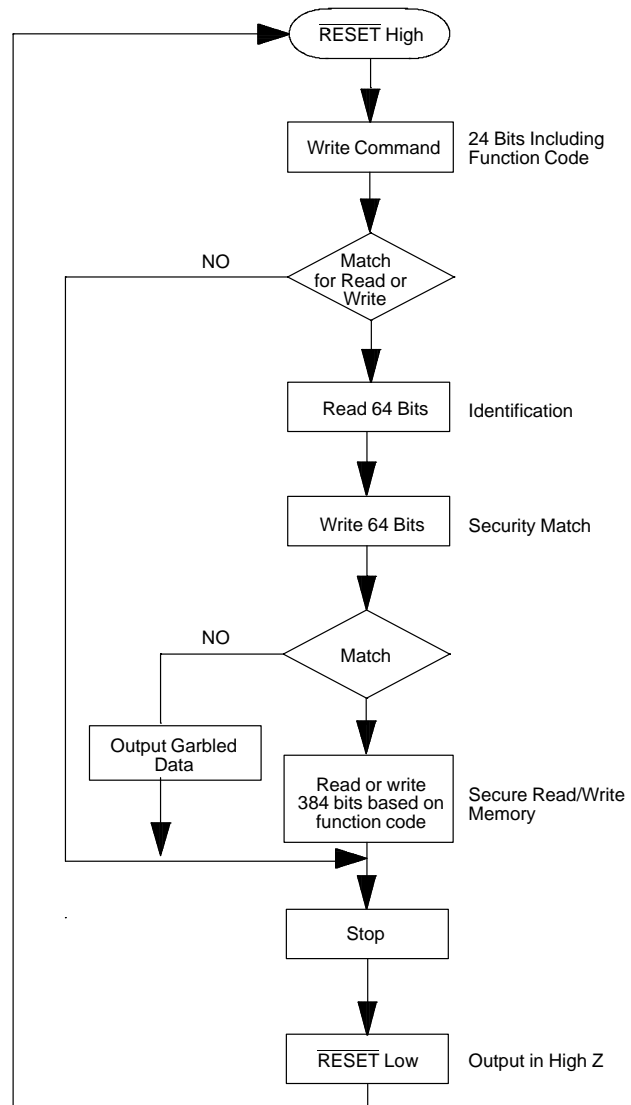
NORMAL MODE: READ OR WRITE SECURE READ/WRITE MEMORY Figure 2A

SEQUENCE: NORMAL MODE, READ OR WRITE SECURE MEMORY Figure 2B

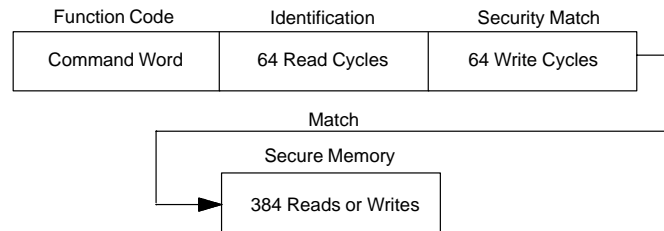

BLOCK DIAGRAM: PROGRAM MODE Figure 3

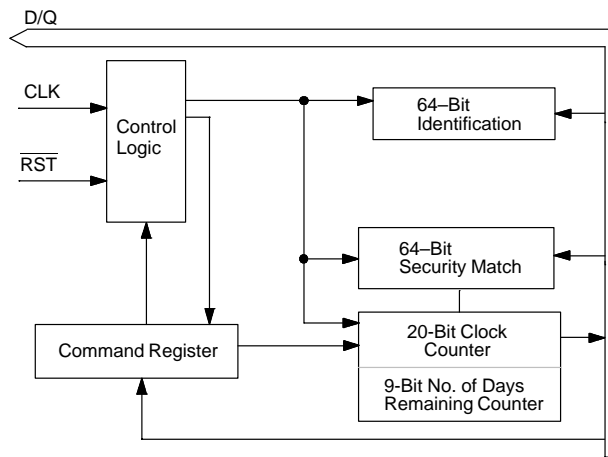

PROGRAM MODE: PROGRAM IDENTIFICATION AND SECURITY MATCH MEMORY Figure 4A

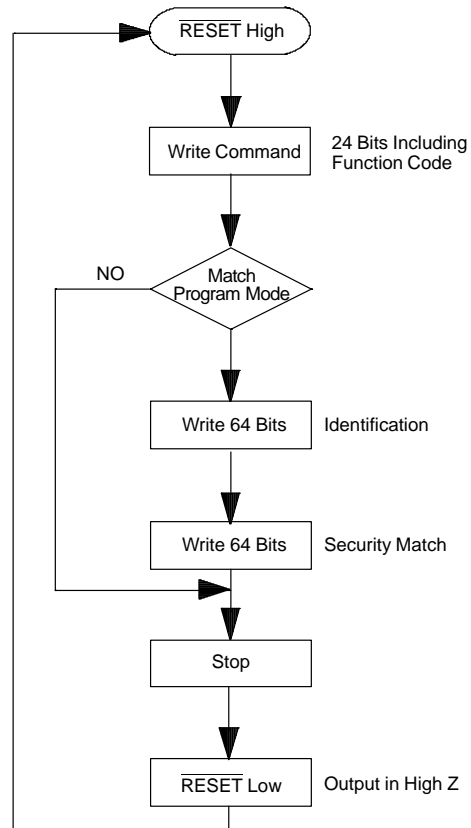

SEQUENCE: PROGRAM MODE, PROGRAM IDENTIFICATION AND SECURITY MATCH BITS Figure 4B

Function Code	Identification	Security Match
Command Word	64 Write Cycles	64 Write Cycles

FLOW CHART: PROGRAM MODE, READING THE 20-BIT DAY CLOCK CALENDAR Figure 5A

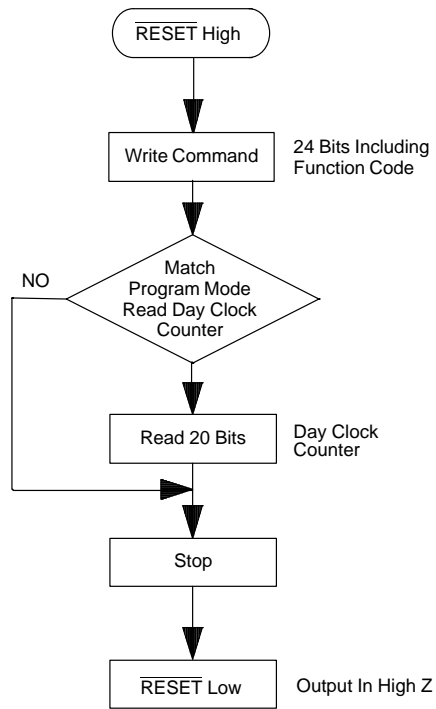

SEQUENCE: PROGRAM MODE, READING THE 20-BIT DAY CLOCK COUNTER Figure 5B



FLOW CHART: PROGRAM, READING THE 9-BIT NUMBER OF DAYS COUNTER Figure 6A

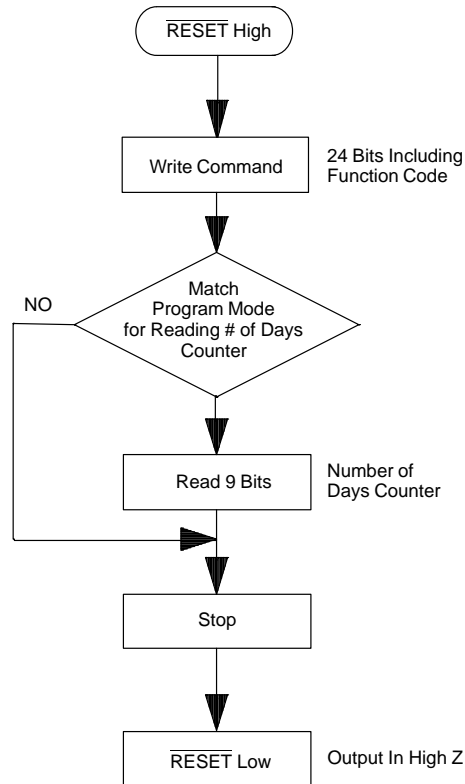

SEQUENCE: PROGRAM MODE, READING THE 9-BIT NUMBER OF DAYS COUNTER Figure 6B



FLOW CHART: PROGRAM MODE, WRITING TO NUMBER OF DAYS COUNTER Figure 7A

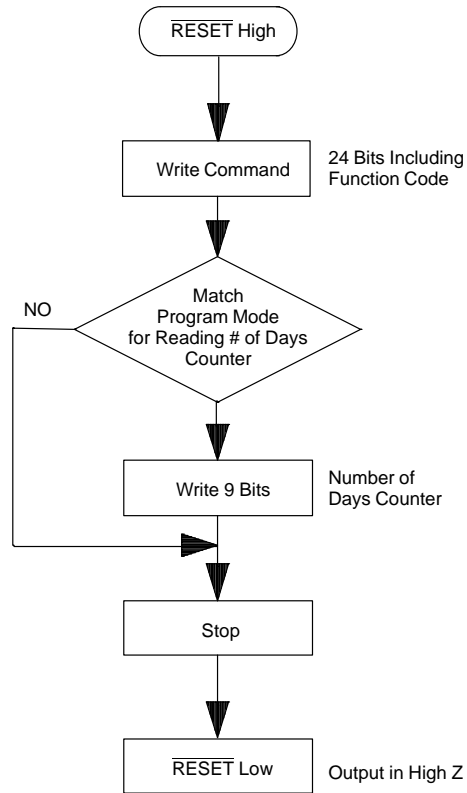

SEQUENCE: PROGRAM MODE, WRITING THE NUMBER OF DAYS COUNTER Figure 7B

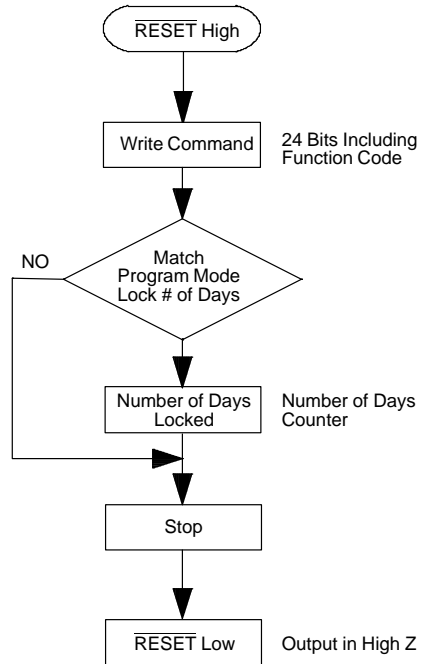
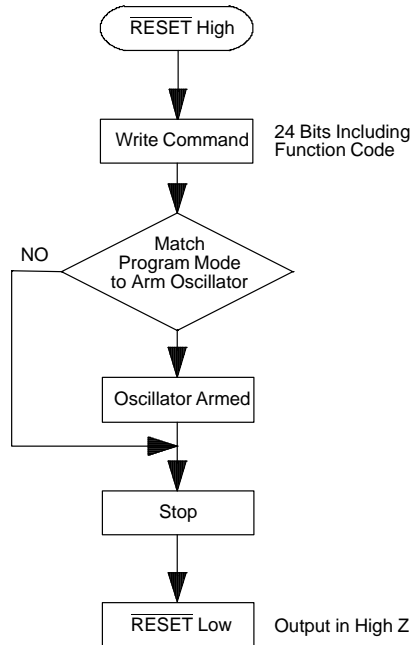

FLOW CHART: PROGRAM MODE, LOCK NUMBER OF DAYS REGISTER Figure 8**FLOW CHART: PROGRAM MODE, ARM OSCILLATOR** Figure 9

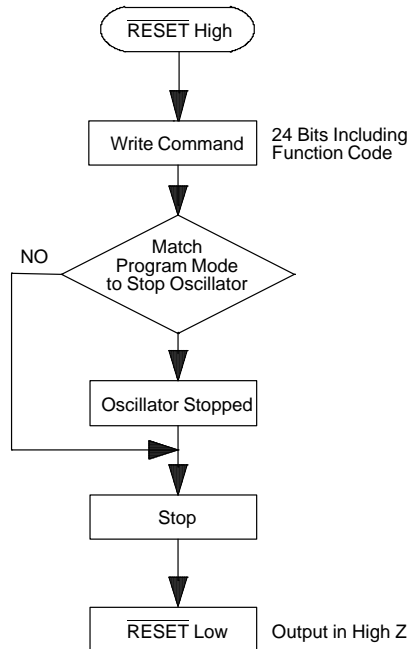
FLOW CHART: PROGRAM MODE, STOP OSCILLATOR Figure 10**SETTING THE TIME UNTIL EXPIRATION OF THE DS1207** Figure 11

Step 1	Program identification memory Program security match bits Write normal mode secure data
Step 2	Program write the number of days remaining Program read the number of days remaining for verification
Step 3*	Issue arm oscillator command
Step 4*	Do a read of any kind
Step 5*	Program read the day clock counter several times (verify that the oscillator is running)
Step 6*	Issue the stop oscillator command
Step 7	Issue the lock command
Step 8	Issue the arm oscillator command (time of expiration will start on first access)

* This is a stress rating only and functional operation of the device at these or any other conditions above those indicated in the operation sections of this specification is not implied. Exposure to absolute maximum rating conditions for extended periods of time may affect reliability.

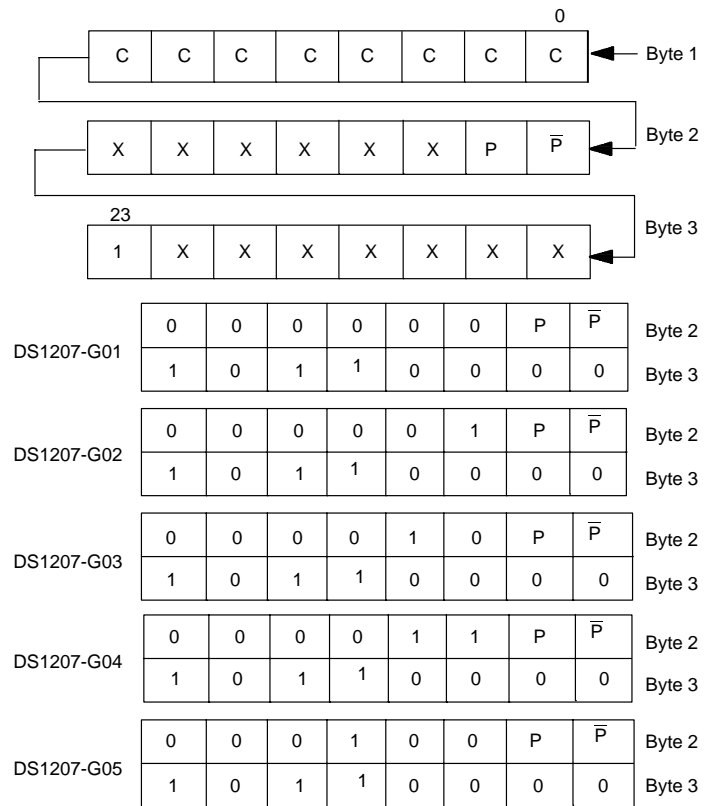
COMMAND WORD Figure 12

FUNCTION CODES: FIRST BYTE OF COMMAND WORD Figure 13

MSB				LSB				
0	1	1	0	0	0	1	0	READ
1	0	0	1	1	1	0	1	WRITE
1	1	1	1	0	0	0	1	READ DAY CLOCK COUNTER
1	1	1	1	0	0	1	0	WRITE NUMBER OF DAYS REMAINING
1	1	1	1	0	0	1	1	READ NUMBER OF DAYS REMAINING
1	1	1	1	0	1	0	0	STOP OSCILLATOR
1	1	1	1	0	1	0	1	ARM OSCILLATOR
1	1	1	1	0	1	1	0	LOCK NUMBER OF DAYS COUNT

DATA TRANSFER: NORMAL MODE, READ OR WRITE SECURE READ/WRITE MEMORY
Figure 14

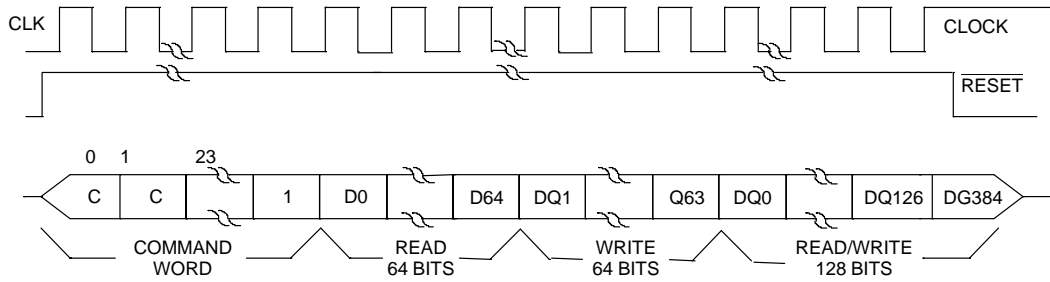

DATA TRANSFER: PROGRAM MODE, PROGRAM IDENTIFICATION AND SECURITY MATCH MEMORY Figure 15A

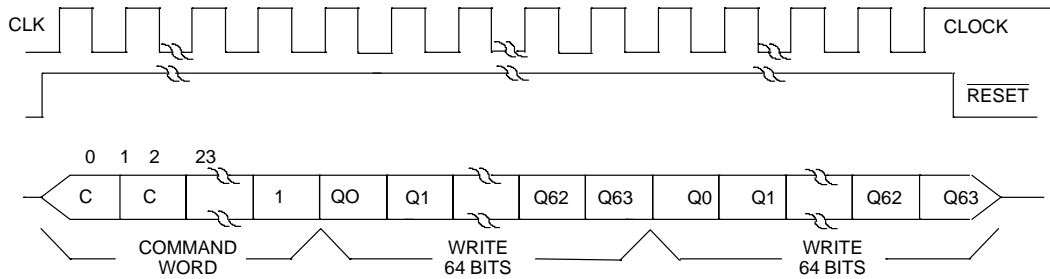

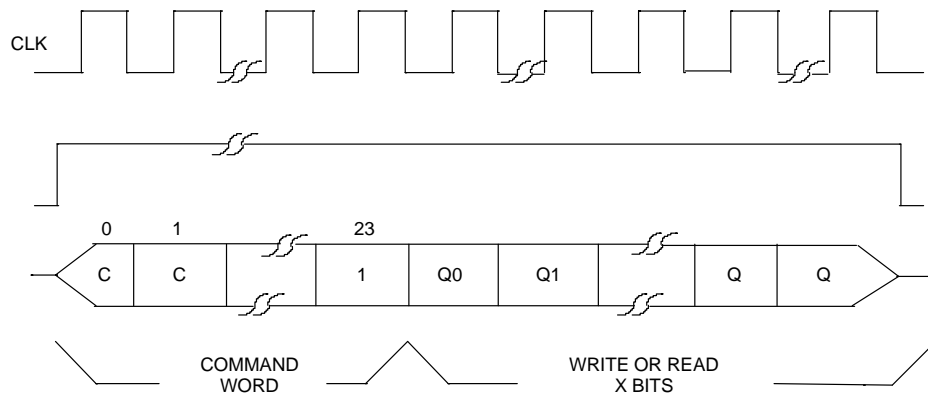
DATA TRANSFER: PROGRAM MODE, DAY CLOCK, DAYS REMAINING AND OSCILLATOR CONTROL Figure 15B

NOTE: The number of bits which follow the command word will be either 0, 9, or 20 bits based on the function code.

ABSOLUTE MAXIMUM RATINGS*

Voltage on any Pin Relative to Ground	-1.0V to +7.0V
Operating Temperature	0°C to 70°C
Storage Temperature	-40°C to +70°C

* This is a stress rating only and functional operation of the device at these or any other conditions above those indicated in the operation sections of this specification is not implied. Exposure to absolute maximum rating conditions for extended periods of time may affect reliability.

RECOMMENDED DC OPERATING CONDITIONS

(0°C to 70°C)

PARAMETER	SYMBOL	MIN	TYP	MAX	UNITS	NOTES
Logic 1	V _{IH}	2.0			V	1
Logic 0	V _{IL}	-0.3		+0.8	V	1
Reset Logic 1	V _{IHE}	3.5			V	1

DC ELECTRICAL CHARACTERISTICS(0°C to 70°C; $\overline{RST} = 3.5V$)

PARAMETER	SYMBOL	MIN	TYP	MAX	UNITS	NOTES
Input Leakage	I _{IL}			+500	μA	4
Output Leakage	I _{LO}			+500	μA	
Output Current @2.4V	I _{OH}	-1			mA	
Output Current @0.4V	I _{OL}			+2	mA	
\overline{RST} Input Resistance	Z _{RST}	10		60	K ohms	
D/Q Input Resistance	Z _{DQ}	10		60	K ohms	
CLK Input Resistance	Z _{CLK}	10		60	K ohms	
\overline{RST} Current @3.5V	I _{RST}			2	mA	6, 9

CAPACITANCE(t_A = 25°C)

PARAMETER	SYMBOL	MIN	TYP	MAX	UNITS	NOTES
Input Capacitance	C _{IN}			5	pF	
Output Capacitance	C _{OUT}			7	pF	

AC ELECTRICAL CHARACTERISTICS

(0°C to 70°C)

PARAMETER	SYMBOL	MIN	TYP	MAX	UNITS	NOTES
Data To CLK Setup	t _{DC}	50			ns	2, 7
CLK to Data Hold	t _{CDH}	70			ns	2, 7
CLK to Data	t _{CDD}			200	ns	2, 3, 5, 7
CLK Low Time Delay	t _{CL}	250			ns	2, 7
CLK High Time	t _{CH}	250			ns	2, 7
CLK Frequency	f _{CLK}	DC		2.0	MHz	2, 7
CLK Rise & Fall	t _R , t _F			500	ns	2, 7
\overline{RST} to CLK Setup	t _{CC}	1			μs	2, 7
CLK to \overline{RST} Hold	t _{CCH}	60			ns	2, 7
\overline{RST} Inactive Time	t _{CWH}	10			ms	2, 7,
\overline{RST} To I/O High Z	t _{CDZ}			70	ns	2, 7

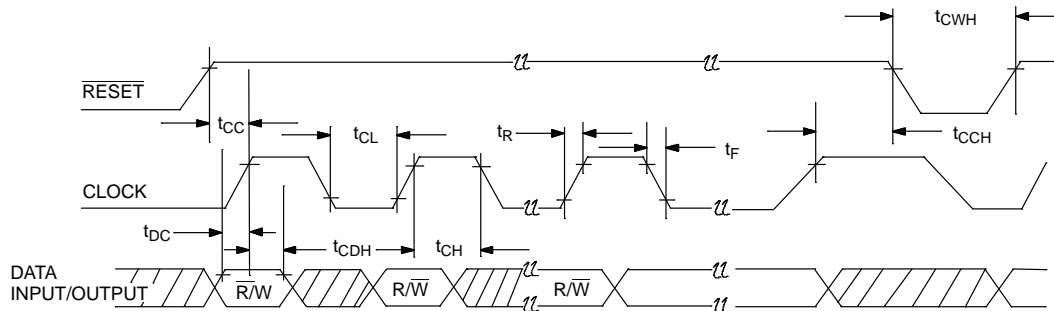
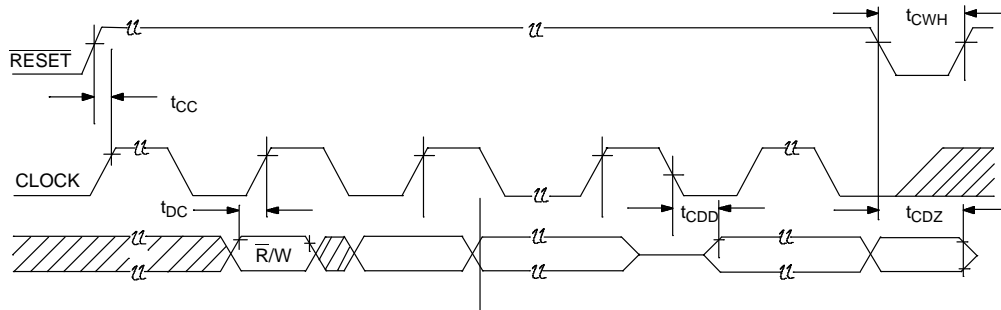
TIMING DIAGRAM: WRITE DATA**TIMING DIAGRAM: READ DATA****NOTES:**

1. All voltages are referenced to GND.
2. Measured at $V_{IH} = 2.0$ or $V_{IL} = .8V$ and 10 ns maximum rise and fall time.
3. Measured at $V_{OH} = 2.4$ volts and $V_{OL} = 0.4$ volts.
4. For CLK, D/Q, and \overline{RST} .
5. Load capacitance = 50 pF.
6. Measured with outputs open.
7. Measured at V_{IH} of \overline{RST} greater than or equal to 3.5 volts.
8. Each DS1207 is marked with a 4-digit code AABB. AA designates the year of manufacture. BB designates the week of manufacture. The expected t_{DR} is defined as starting at the date of manufacture.
9. Average AC \overline{RST} current can be determined using the following formula:

$$I_{TOTAL} = 2 + I_{LOAD\ DC} + (4 \times 10^{-3})(CL + 280)^f$$

$$I_{TOTAL} \text{ and } I_{LOAD} \text{ are in mA; } CL \text{ is in pF; } f \text{ is in MHz.}$$
 Applying the above formula, a load capacitance of 50 pF running at a frequency of 2.0 MHz gives an I_{TOTAL} of 1.6 mA.