

ATABX051

Features

- Compatible with 40-pin MCS-51™ sockets
- Compatible with in-circuit-emulators with 40-pin sockets
- 32 Programmable I/O Lines or 15 Programmable I/O Lines

Description⁽¹⁾

Atmel's 20- to 40-pin adapter board is for use in designing AT89C1051/AT89C2051 systems. The ATABX051 maps the pins on the 20-pin device to the corresponding pin locations in a 40-pin 80C51 footprint. Customers can use this board to adapt existing in-circuit-emulators for use in AT89C1051/AT89C2051 designs (note that a comparator must also be added for full emulation) or to plug in 40-pin 80C51 devices into 20-pin AT89C1051/AT89C2051 sockets. In addition, the board can be used to adapt the 20-pin footprint to an existing 40-pin socket.

Microcontroller Two Way Adaptor Board

Pin Configurations

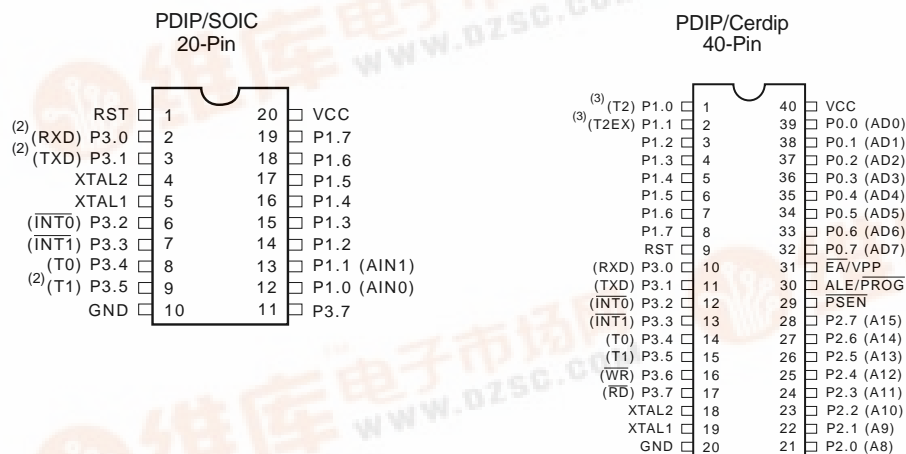

- Notes:
1. This adapter cannot be used with programmers for programming purposes. Although the pins are defined the same in operation mode, the pin definitions and algorithms are different from the AT89C51 in programming mode.
 2. Pins (RXD) P3.0, (TXD) P3.1, and (T1) P3.5 are AT89C2051 pins only, but not for AT89C1051.
 3. Pins (T2) P1.0 and (T2EX) P1.1 are AT89C52 pins only.





ABX051 Two Way Adapter Board

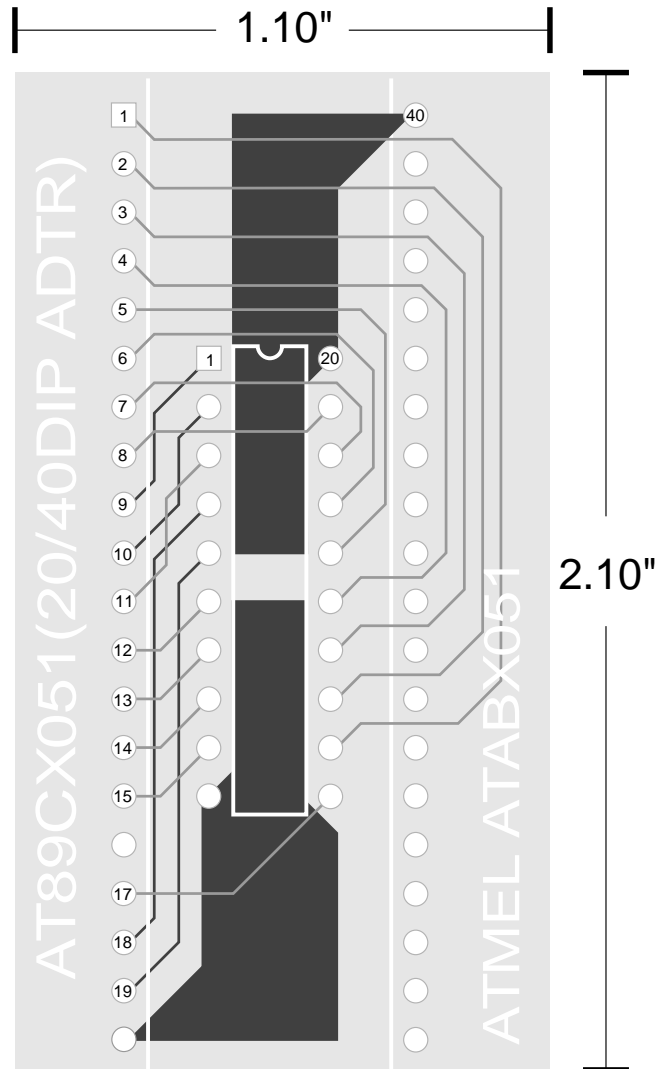

Board Characteristics

1. Holes: .040 Diameter; Plated
2. Material: .063 Thick FR4; 10Z Copper
3. Finish: SMOBC
4. Soldermask both sides per artwork

Ordering Information

Contact the lead Atmel Sales Representative for availability and ordering information.