

SMT Inductors, SIMID Series

B82494-A

SIMID 1008-A, SIMID 1008-G

B82494-G

SMD

Size 1008 (EIA) or 2520 (IEC)
Rated inductance 0,010 to 100 μ H
Rated current 10 to 280 mA



Construction

- Ferrite core
- Molded epoxy encapsulation

Features

- High Q factor
- High resonance frequency
- Suitable for reflow (IR and vapor phase) and wave soldering

Applications

- Filtering of supply voltages, coupling, decoupling
- Antenna systems
- Automotive electronics
- Telecommunications

Terminals

- Electro-plated
- 2–4 μ m Ni, $\geq 5 \mu$ m Sn60Pb40
- Base material phosphor bronze

Marking

Marking on component:
L value (in μ H)

Minimum data on reel:
Manufacturer, part number, ordering code,
L value and tolerance of L value,
quantity, date of packing

Delivery mode

8-mm blister tape, wound on 178-mm \varnothing reel
For details on taping, packing and packing units [see page 153](#)





SMT Inductors, SIMID Series

B82494-A

SIMID 1008-A, SIMID 1008-G

B82494-G



General technical data

Rated inductance L_R	Measured with impedance analyzer HP 4191A at frequency f_L
Q factor Q_{\min}	Measured with impedance analyzer HP 4191A at frequency f_Q
Rated current I_R	Maximum permissible dc with inductance decrease $\Delta L/L_0 \leq 10\%$ and temperature increase of $\leq 20\text{ K}$ at rated temperature of 85°C
Self-resonance frequency $f_{\text{res, min}}$	Measured with network analyzer HP 8753
DC resistance R_{max}	Measured at 20°C ambient temperature, measuring current $< I_R$
Climatic category	In accordance with IEC 60068-1 55/085/56 ($-55^\circ\text{C}/+85^\circ\text{C}/56$ days damp heat test)
Solderability	In accordance with IEC 60062-2-58 ($230 \pm 5^\circ\text{C}$, $(3 \pm 0,5)$ s Wetting of soldering area: $\geq 90\%$
Resistance to soldering heat	In accordance with IEC 60068-2-20 260°C , 10 s $\Delta L/L \leq \pm 5\%$; $\Delta Q/Q \leq \pm 20\%$ after 5 minutes preheating at 120°C
Permissible PCB bending	2 mm (100 mm long standard PCB)
Weight	Approx. 21 mg



Dimensional drawing

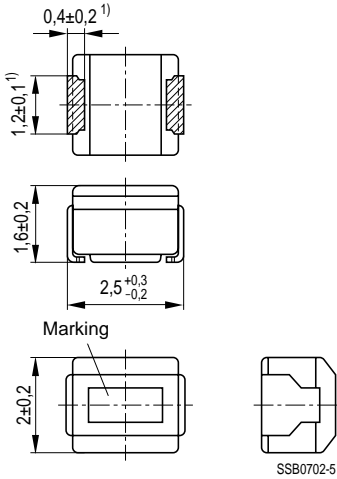

Layout recommendation

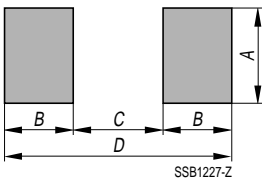

Dimensions (mm)	A	B	C	D
Wave soldering	1,2	1,25	1,5	4,0
Reflow soldering	1,6	1,05	1,5	3,5



SMT Inductors, SIMID Series

B82494-A

SIMID 1008-A, SIMID 1008-G

B82494-G



Characteristics and ordering codes

L_R μH	Tolerance	Q_{min}	$f_L; f_Q$ MHz	I_R mA	R_{max} Ω	$f_{res, min}$ MHz	Ordering code
Non-shielded							
0,010	± 10 % △ K	10	100	280	0,32	2500	B82494-A1100-K
0,012		10	100	270	0,34	2200	B82494-A1120-K
0,015		10	100	255	0,38	1800	B82494-A1150-K
0,018		10	100	250	0,40	1550	B82494-A1180-K
0,022		15	100	240	0,43	1350	B82494-A1220-K
0,027		15	100	230	0,47	1150	B82494-A1270-K
0,033		15	100	220	0,51	1000	B82494-A1330-K
0,039		15	100	215	0,55	890	B82494-A1390-K
0,047		15	100	205	0,59	770	B82494-A1470-K
0,056		15	100	200	0,63	670	B82494-A1560-K
0,068		15	100	190	0,68	590	B82494-A1680-K
0,082		15	100	185	0,73	520	B82494-A1820-K
0,10		10	25,2	175	0,80	460	B82494-A1101-K
0,12		10	25,2	170	0,87	400	B82494-A1121-K
0,15		10	25,2	160	0,98	340	B82494-A1151-K
0,18	10	25,2	155	1,05	300	B82494-A1181-K	
0,22	25	25,2	190	0,70	230	B82494-A1221-K	
0,27	25	25,2	180	0,75	210	B82494-A1271-K	
0,33	25	25,2	170	0,85	190	B82494-A1331-K	
0,39	25	25,2	160	0,95	175	B82494-A1391-K	
0,47	25	25,2	155	1,00	160	B82494-A1471-K	
0,56	25	25,2	150	1,10	150	B82494-A1561-K	
0,68	25	25,2	140	1,25	135	B82494-A1681-K	
0,82	25	25,2	130	1,40	125	B82494-A1821-K	
1,0	25	7,96	195	0,65	115	B82494-A1102-K	
1,2	25	7,96	180	0,75	100	B82494-A1122-K	
1,5	25	7,96	170	0,85	90	B82494-A1152-K	
1,8	25	7,96	160	0,95	85	B82494-A1182-K	
2,2	25	7,96	155	1,05	80	B82494-A1222-K	
2,7	25	7,96	145	1,20	75	B82494-A1272-K	
3,3	25	7,96	135	1,30	65	B82494-A1332-K	
3,9	25	7,96	130	1,40	60	B82494-A1392-K	
4,7	25	7,96	125	1,55	55	B82494-A1472-K	



SMT Inductors, SIMID Series

B82494-A

SIMID 1008-A, SIMID 1008-G

B82494-G



Characteristics and ordering codes (continued)

L_R μH	Tolerance	Q_{\min}	$f_L; f_Q$ MHz	I_R mA	R_{\max} Ω	$f_{\text{res, min}}$ MHz	Ordering code
Non-shielded							
5,6	$\pm 10\%$ $\triangleq K$	25	7,96	120	1,75	50	B82494-A1562-K
6,8		25	7,96	115	1,95	45	B82494-A1682-K
8,2		25	7,96	105	2,2	40	B82494-A1822-K
10		25	2,52	80	3,5	32	B82494-A1103-K
12		25	2,52	75	3,8	30	B82494-A1123-K
15		25	2,52	70	4,4	28	B82494-A1153-K
18		25	2,52	65	5,0	25	B82494-A1183-K
22		25	2,52	60	5,8	22	B82494-A1223-K
27		20	2,52	115	6,3	21	B82494-A1273-K
33		20	2,52	110	7,1	20	B82494-A1333-K
39		20	2,52	90	9,5	18	B82494-A1393-K
47		20	2,52	80	11,0	17	B82494-A1473-K
56		20	2,52	75	12,1	16	B82494-A1563-K
68		20	2,52	70	16,6	15	B82494-A1683-K
82		20	2,52	65	19,0	13	B82494-A1823-K
100	15	0,796	60	21,0	12	B82494-A1104-K	
Shielded ¹⁾							
27	$\pm 10\%$ $\triangleq K$	40	2,52	18	4,5	20	B82494-G1273-K
33		40	2,52	14	5,2	18	B82494-G1333-K
39		40	2,52	13	5,7	15	B82494-G1393-K
47		40	2,52	12	6,6	14	B82494-G1473-K
56		40	2,52	10	7,1	13	B82494-G1563-K
68		25	2,52	17	6,5	13	B82494-G1683-K
82		25	2,52	14	7,4	13	B82494-G1823-K
100		25	0,796	10	8,4	12	B82494-G1104-K



中发网 WWW.ZFA.CN

全球最大的PDF中文下载站



中发网
www.zfa.cn

PDF 资料下载尽在中发网