

## PROGRAMMABLE OUTPUT POWER FACTOR PREREGULATOR

### FEATURES

- Controls Boost Preregulator to Near-Unity Power Factor
- World Wide Line Operation
- Over-Voltage Protection
- Accurate Power Limiting
- Average Current Mode Control
- Improved Noise Immunity
- Improved Feed-Forward Line Regulation
- Leading Edge Modulation
- 150- $\mu$ A Typical Start-Up Current
- Low-Power BiCMOS Operation
- 10.8-V to 17-V Operation
- Programmable Output Voltage (Tracking Boost Topology)

### DESCRIPTION

The UCC2819A/UCC3819A provides all the functions necessary for active power factor corrected preregulators. The controller achieves near unity power factor by shaping the ac-input line current waveform to correspond to that of the ac-input line voltage. Average current mode control maintains stable, low distortion sinusoidal line current.

Designed in Texas Instrument's BiCMOS process, the UCC3819A offers new features such as lower start-up current, lower power dissipation, overvoltage protection, a shunt UVLO detect circuitry and a leading-edge modulation technique to reduce ripple current in the bulk capacitor.

The UCC3819A allows the output voltage to be programmed by bringing out the error amplifier noninverting input.

### BLOCK DIAGRAM

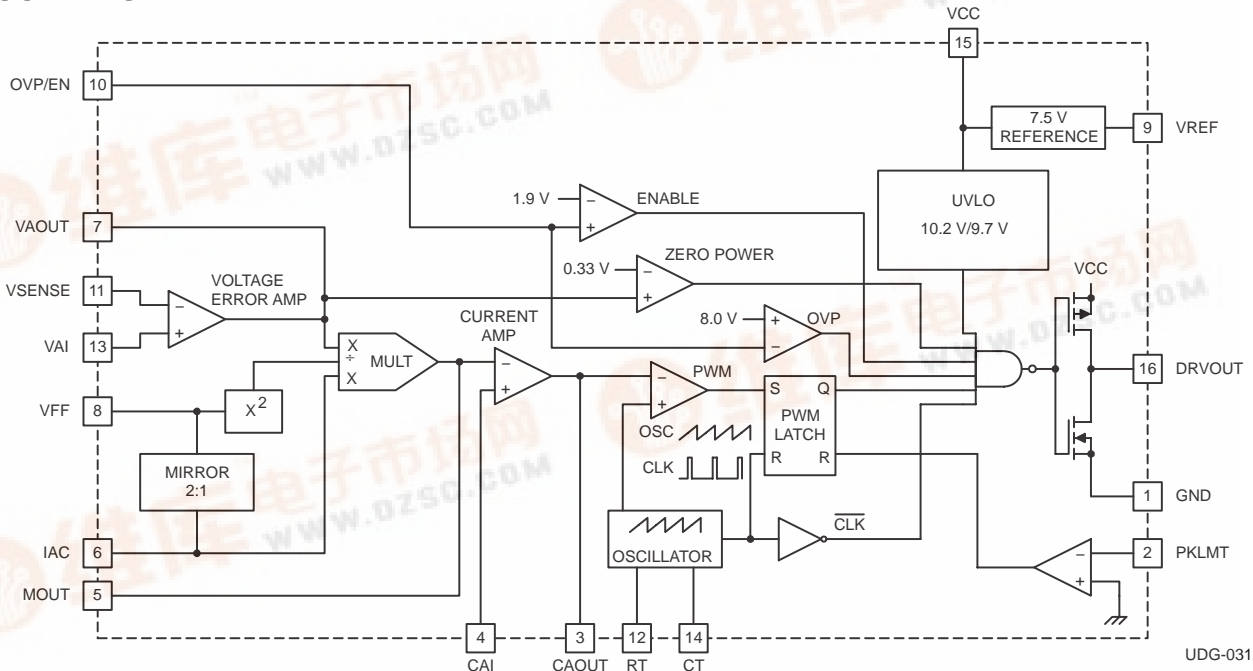

UDG-03124

Please be aware that an important notice concerning availability, standard warranty, and use in critical applications of Texas Instruments semiconductor products and disclaimers thereto appears at the end of this data sheet.



# UCC2819A UCC3819A

SLUS579 – OCTOBER, 2003

## DESCRIPTION (CONTINUED)

The UCC3819A is directly pin for pin compatible with the UCC3819. Only the output stage of UCC3819A has been modified to allow use of a smaller external gate drive resistor values. For some power supply designs where an adequately high enough gate drive resistor can not be used, the UCC3819A offers a more robust output stage at the cost of increasing the internal gate resistances. The gate drive of the UCC3819A remains strong at  $\pm 1.2$  A of peak current capability.

Available in the 16-pin D, N, and PW packages.

## PIN CONNECTION DIAGRAM

**D, N, AND PW PACKAGES  
(TOP VIEW)**

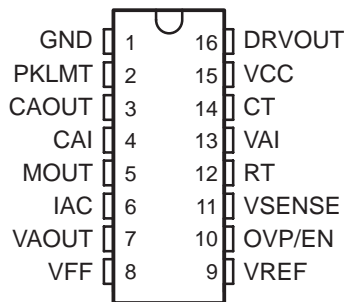

**AVAILABLE OPTIONS TABLE**

T <sub>A</sub> = T <sub>J</sub>	PACKAGE DEVICES		
	SOIC (D) PACKAGE(1)	PDIP (N) PACKAGE	TSSOP (PW) PACKAGE(1)
0°C to 70°C	UCC3819AD	UCC3819AN	UCC3819APW
-40°C to 85°C	UCC2819AD	UCC2819AN	UCC2819APW

NOTES: (1) The D and PW packages are available taped and reeled. Add R suffix to the device type (e.g. UCC3819ADR) to order quantities of 2,500 devices per reel (D package) and 2,000 devices per reel (for PW package). Bulk quantities are 40 units (D package) and 90 units (PW package) per tube.

**THERMAL RESISTANCE TABLE**

PACKAGE	$\theta_{jc}$ (°C/W)	$\theta_{ja}$ (°C/W)
SOIC-16 (D)	22	40 to 70 (1)
PDIP-16 (N)	12	25 to 50 (1)
TSSOP-16 (PW)	14 (2)	123 to 147 (2)

NOTES: (1) Specified  $\theta_{ja}$  (junction to ambient) is for devices mounted to 5-inch<sup>2</sup> FR4 PC board with one ounce copper where noted. When resistance range is given, lower values are for 5 inch<sup>2</sup> aluminum PC board. Test PWB was 0.062 inch thick and typically used 0.635-mm trace widths for power packages and 1.3-mm trace widths for non-power packages with a 100-mil x 100-mil probe land area at the end of each trace.

(2) Modeled data. If value range given for  $\theta_{ja}$ , lower value is for 3x3 inch. 1 oz internal copper ground plane, higher value is for 1x1-inch. ground plane. All model data assumes only one trace for each non-fused lead.

## ABSOLUTE MAXIMUM RATINGS

over operating free-air temperature (unless otherwise noted)†

	UCCx81xA	UNIT
Supply voltage VCC	18	V
Gate drive current, continuous	0.2	A
Gate drive current	1.2	
Input voltage, CAI, MOUT, SS	8	V
Input voltage, PKLMT	5	
Input voltage, VSENSE, OVP/EN, VAI	10	
Input current, RT, IAC, PKLMT	10	mA
Maximum negative voltage, DRVOUT, PKLMT, MOUT	-0.5	V
Power dissipation	1	W
Junction temperature, T <sub>J</sub>	-55 to 150	°C
Storage temperature, T <sub>stg</sub>	-65 to 150	
Lead temperature, T <sub>sol</sub> (soldering, 10 seconds)	300	

† Stresses beyond those listed under “absolute maximum ratings” may cause permanent damage to the device. These are stress ratings only, and functional operation of the device at these or any other conditions beyond those indicated under recommended operating conditions is not implied. Exposure to absolute-maximum-rated conditions for extended periods may affect device reliability.

## ELECTRICAL CHARACTERISTICS

T<sub>A</sub> = 0°C to 70°C for the UCC3819A, -40°C to 85°C for the UCC2819A, VCC = 12 V, R<sub>T</sub> = 22 kΩ, C<sub>T</sub> = 270 pF, (unless otherwise noted)

PARAMETER	TEST CONDITIONS	MIN	TYP	MAX	UNITS
<b>Supply Current</b>					
Supply current, off	VCC = (VCC turnon threshold - 0.3 V)		150	300	μA
Supply current, on	VCC = 12 V, No load on DRVOUT	2	4	6	mA
<b>UVLO</b>					
VCC turnon threshold		9.7	10.2	10.8	V
VCC turnoff threshold		9.4	9.7		
UVLO hysteresis		0.3	0.5		
<b>Voltage Amplifier</b>					
VIO	VAOUT = 2.75 V, VCM = 3.75 V	-15		15	mV
VAI bias current	VAOUT = 2.75 V, VCM = 3.75 V		50	200	nA
VSENSE bias current	VSENSE = VREF, VAOUT = 2.5 V		50	200	
CMRR	VCM = 1 V to 7.5 V	50	70		dB
Open loop gain	VAOUT = 2 V to 5 V	50	90		
High-level output voltage	I <sub>L</sub> = -150 μA	5.3	5.5	5.6	V
Low-level output voltage	I <sub>L</sub> = 150 μA	0	50	150	mV

- NOTES: 1. Ensured by design, Not production tested.  
2. Reference variation for V<sub>CC</sub> < 10.8 V is shown in Figure 2.

# UCC2819A UCC3819A

SLUS579 – OCTOBER, 2003

## ELECTRICAL CHARACTERISTICS

$T_A = 0^\circ\text{C}$  to  $70^\circ\text{C}$  for the UCC3819A,  $-40^\circ\text{C}$  to  $85^\circ\text{C}$  for the UCC2819A,  $V_{CC} = 12\text{ V}$ ,  $R_T = 22\text{ k}\Omega$ ,  $C_T = 270\text{ pF}$ , (unless otherwise noted)

PARAMETER	TEST CONDITIONS	MIN	TYP	MAX	UNITS
<b>Over Voltage Protection and Enable</b>					
Over voltage reference		$V_{REF} + 0.48$	$V_{REF} + 0.50$	$V_{REF} + 0.52$	V
Hysteresis		300	500	600	mV
Enable threshold		1.7	1.9	2.1	V
Enable hysteresis		0.1	0.2	0.3	
<b>Current Amplifier</b>					
Input offset voltage	$V_{CM} = 0\text{ V}$ , $V_{CAOUT} = 3\text{ V}$	-3.5	0	2.5	mV
Input bias current	$V_{CM} = 0\text{ V}$ , $V_{CAOUT} = 3\text{ V}$		-50	-100	nA
Input offset current	$V_{CM} = 0\text{ V}$ , $V_{CAOUT} = 3\text{ V}$		25	100	
Open loop gain	$V_{CM} = 0\text{ V}$ , $V_{CAOUT} = 2\text{ V to } 5\text{ V}$	90			dB
Common-mode rejection ratio	$V_{CM} = 0\text{ V to } 1.5\text{ V}$ , $V_{CAOUT} = 3\text{ V}$	60	80		
High-level output voltage	$I_L = -120\text{ }\mu\text{A}$	5.6	6.5	6.8	V
Low-level output voltage	$I_L = 1\text{ mA}$	0.1	0.2	0.5	
Gain bandwidth product	See Note 1		2.5		MHz
<b>Voltage Reference</b>					
Input voltage, (UCC3819A)	$T_A = 0^\circ\text{C to } 70^\circ\text{C}$	7.387	7.5	7.613	V
Input voltage, (UCC2819A)	$T_A = -40^\circ\text{C to } 85^\circ\text{C}$	7.369	7.5	7.631	
Load regulation	$I_{REF} = 1\text{ mA to } 2\text{ mA}$	0		10	mV
Line regulation	$V_{CC} = 10.8\text{ V to } 15\text{ V}$ , See Note 2	0		10	
Short-circuit current	$V_{REF} = 0\text{ V}$	-20	-25	-50	mA
<b>Oscillator</b>					
Initial accuracy	$T_A = 25^\circ\text{C}$	85	100	115	kHz
Voltage stability	$V_{CC} = 10.8\text{ V to } 15\text{ V}$	-1%		1%	
Total variation	Line, temp, See Note 1	80		120	kHz
Ramp peak voltage		4.5	5	5.5	V
Ramp amplitude voltage (peak to peak)		3.5	4	4.5	
<b>Peak Current Limit</b>					
PKLMT reference voltage		-15		15	mV
PKLMT propagation delay		150	350	500	ns

NOTES: (1) Ensured by design, Not production tested.  
(2) Reference variation for  $V_{CC} < 10.8\text{ V}$  is shown in Figure 2.

**ELECTRICAL CHARACTERISTICS**

$T_A = 0^\circ\text{C}$  to  $70^\circ\text{C}$  for the UCC3819A,  $-40^\circ\text{C}$  to  $85^\circ\text{C}$  for the UCC2819A,  $V_{CC} = 12\text{ V}$ ,  $R_T = 22\text{ k}\Omega$ ,  $C_T = 270\text{ pF}$ , (unless otherwise noted)

PARAMETER	TEST CONDITIONS	MIN	TYP	MAX	UNITS
<b>Multiplier</b>					
$I_{MOUT}$ , high line, low power output current, ( $0^\circ\text{C}$ to $85^\circ\text{C}$ )	$I_{AC} = 500\ \mu\text{A}$ , $V_{FF} = 4.7\text{ V}$ , $VA_{OUT} = 1.25\text{ V}$	0	-6	-20	$\mu\text{A}$
$I_{MOUT}$ , high line, low power output current, ( $-40^\circ\text{C}$ to $85^\circ\text{C}$ )	$I_{AC} = 500\ \mu\text{A}$ , $V_{FF} = 4.7\text{ V}$ , $VA_{OUT} = 1.25\text{ V}$	0		-23	
$I_{MOUT}$ , high line, high power output current	$I_{AC} = 500\ \mu\text{A}$ , $V_{FF} = 4.7\text{ V}$ , $VA_{OUT} = 5\text{ V}$	-70	-90	-105	
$I_{MOUT}$ , low line, low power output current	$I_{AC} = 150\ \mu\text{A}$ , $V_{FF} = 1.4\text{ V}$ , $VA_{OUT} = 1.25\text{ V}$	-10	-19	-50	
$I_{MOUT}$ , low line, high power output current	$I_{AC} = 150\ \mu\text{A}$ , $V_{FF} = 1.4\text{ V}$ , $VA_{OUT} = 5\text{ V}$	-268	-300	-346	
$I_{MOUT}$ , IAC limited	$I_{AC} = 150\ \mu\text{A}$ , $V_{FF} = 1.3\text{ V}$ , $VA_{OUT} = 5\text{ V}$	-250	-300	-400	
Gain constant (K)	$I_{AC} = 300\ \mu\text{A}$ , $V_{FF} = 3\text{ V}$ , $VA_{OUT} = 2.5\text{ V}$	0.5	1	1.5	1/V
$I_{MOUT}$ , zero current	$I_{AC} = 150\ \mu\text{A}$ , $V_{FF} = 1.4\text{ V}$ , $VA_{OUT} = 0.25\text{ V}$		0	-2	$\mu\text{A}$
	$I_{AC} = 500\ \mu\text{A}$ , $V_{FF} = 4.7\text{ V}$ , $VA_{OUT} = 0.25\text{ V}$		0	-2	
$I_{MOUT}$ , zero current, ( $0^\circ\text{C}$ to $85^\circ\text{C}$ )	$I_{AC} = 500\ \mu\text{A}$ , $V_{FF} = 4.7\text{ V}$ , $VA_{OUT} = 0.5\text{ V}$		0	-3	
$I_{MOUT}$ , zero current, ( $-40^\circ\text{C}$ to $85^\circ\text{C}$ )	$I_{AC} = 500\ \mu\text{A}$ , $V_{FF} = 4.7\text{ V}$ , $VA_{OUT} = 0.5\text{ V}$		0	-3.5	
Power limit ( $I_{MOUT} \times V_{FF}$ )	$I_{AC} = 150\ \mu\text{A}$ , $V_{FF} = 1.4\text{ V}$ , $VA_{OUT} = 5\text{ V}$	-375	-420	-485	$\mu\text{W}$
<b>Feed-Forward</b>					
VFF output current	$I_{AC} = 300\ \mu\text{A}$	-140	-150	-160	$\mu\text{A}$
<b>Gate Driver</b>					
Pullup resistance	$I_O = -100\text{ mA}$ to $-200\text{ mA}$		9	12	$\Omega$
Pulldown resistance	$I_O = 100\text{ mA}$		4	10	
Output rise time	$C_L = 1\text{ nF}$ , $R_L = 10\ \Omega$ , $V_{DRVOUT} = 0.7\text{ V}$ to $9\text{ V}$		25	50	ns
Output fall time	$C_L = 1\text{ nF}$ , $R_L = 10\ \Omega$ , $V_{DRVOUT} = 9\text{ V}$ to $0.7\text{ V}$		10	50	
Maximum duty cycle		93%	95%	100%	
Minimum controlled duty cycle	At 100 kHz			2%	
<b>Zero Power</b>					
Zero power comparator threshold	Measured on $VA_{OUT}$	0.20	0.33	0.50	V

NOTES: (1) Ensured by design, Not production tested.  
(2) Reference variation for  $V_{CC} < 10.8\text{ V}$  is shown in Figure 2.

# UCC2819A UCC3819A

SLUS579 – OCTOBER, 2003

## PIN ASSIGNMENTS

TERMINAL		I/O	DESCRIPTION
NAME	NO.		
CAI	4	I	Current amplifier noninverting input
CAOUT	3	O	Current amplifier output
CT	14	I	Oscillator timing capacitor
DRVOUT	16	O	Gate drive
GND	1	–	Ground
IAC	6	I	Current proportional to input voltage
MOUT	5	I/O	Multiplier output and current amplifier inverting input
OVP/EN	10	I	Over-voltage/enable
PKLMT	2	I	PFC peak current limit
RT	12	I	Oscillator charging current
VAI	13	I	Voltage amplifier non-inverting input
VAOUT	7	O	Voltage amplifier output
VCC	15	I	Positive supply voltage
VFF	8	I	Feed-forward voltage
VSENSE	11	I	Voltage amplifier inverting input
VREF	9	O	Voltage reference output

## Pin Descriptions

**CAI:** Place a resistor between this pin and the GND side of current-sense resistor. This input and the inverting input (MOUT) remain functional down to and below GND.

**CAOUT:** This is the output of a wide bandwidth operational amplifier that senses line current and commands the PFC pulse-width modulator (PWM) to force the correct duty cycle. Compensation components are placed between CAOUT and MOUT.

**CT:** A capacitor from CT to GND sets the PWM oscillator frequency according to:

$$f \approx \left( \frac{0.6}{RT \times CT} \right)$$

The lead from the oscillator timing capacitor to GND should be as short and direct as possible.

**DRVOUT:** The output drive for the boost switch is a totem-pole MOSFET gate driver on DRVOUT. To avoid the excessive overshoot of the DRVOUT while driving a capacitive load, a series gate current-limiting/damping resistor is recommended to prevent interaction between the gate impedance and the output driver. The value of the series gate resistor is based on the pulldown resistance ( $R_{\text{pulldown}}$  which is 4- $\Omega$  typical), the maximum VCC voltage (VCC), and the required maximum gate drive current ( $I_{\text{max}}$ ). Using the equation below, a series gate resistance of resistance 11  $\Omega$  would be required for a maximum VCC voltage of 18 V and for 1.2 A of maximum sink current. The source current will be limited to approximately 900 mA (based on the  $R_{\text{pullup}}$  of 9- $\Omega$  typical).

$$R_{\text{GATE}} = \frac{VCC - (I_{\text{MAX}} \times R_{\text{pulldown}})}{I_{\text{MAX}}}$$

**GND:** All voltages measured with respect to ground. VCC and REF should be bypassed directly to GND with a 0.1- $\mu$ F or larger ceramic capacitor.

## Pin Descriptions (continued)

**IAC:** This input to the analog multiplier is a current proportional to instantaneous line voltage. The multiplier is tailored for very low distortion from this current input ( $I_{IAC}$ ) to multiplier output. The recommended maximum  $I_{IAC}$  is 500  $\mu$ A.

**MOUT:** The output of the analog multiplier and the inverting input of the current amplifier are connected together at MOUT. As the multiplier output is a current, this is a high-impedance input so the amplifier can be configured as a differential amplifier. This configuration improves noise immunity and allows for the leading-edge modulation operation. The multiplier output current is limited to  $(2 \times I_{IAC})$ . The multiplier output current is given by the equation:

$$I_{MOUT} = \frac{I_{IAC} \times (V_{VAOUT} - 1)}{V_{VFF}^2 \times K}$$

where  $K = \frac{1}{V}$  is the multiplier gain constant.

**OVP/EN:** A window comparator input that disables the output driver if the boost output voltage is a programmed level above the nominal or disables both the PFC output driver and resets SS if pulled below 1.9 V (typ).

**PKLMT:** The threshold for peak limit is 0 V. Use a resistor divider from the negative side of the current sense resistor to VREF to level shift this signal to a voltage level defined by the value of the sense resistor and the peak current limit. Peak current limit is reached when PKLMT voltage falls below 0 V.

**RT:** A resistor from RT to GND is used to program oscillator charging current. A resistor between 10 k $\Omega$  and 100 k $\Omega$  is recommended. Nominal voltage on this pin is 3 V.

**VAI:** This input can be tied to the VREF or any other voltage reference ( $\leq 7.5$  V) to set the boost regulator output voltage.

**VAOUT:** This is the output of the operational amplifier that regulates output voltage. The voltage amplifier output is internally limited to approximately 5.5 V to prevent overshoot.

**VCC:** Connect to a stable source of at least 20 mA between 10 V and 17 V for normal operation. Bypass VCC directly to GND to absorb supply current spikes required to charge external MOSFET gate capacitances. To prevent inadequate gate drive signals, the output devices are inhibited unless  $V_{VCC}$  exceeds the upper under-voltage lockout voltage threshold and remains above the lower threshold.

**VFF:** The RMS voltage signal generated at this pin by mirroring 1/2 of the  $I_{IAC}$  into a single pole external filter. At low line, the VFF roll should be 14 V.

**VSENSE:** This is normally connected to a compensation network and to the boost converter output through a divider network.

**VREF:** VREF is the output of an accurate 7.5-V voltage reference. This output is capable of delivering 20 mA to peripheral circuitry and is internally short-circuit current limited. VREF is disabled and remains at 0 V when  $V_{VCC}$  is below the UVLO threshold. Bypass VREF to GND with a 0.1- $\mu$ F or larger ceramic capacitor for best stability. Please refer to Figures 8 and 9 for VREF line and load regulation characteristics.

# UCC2819A UCC3819A

SLUS579 – OCTOBER, 2003

## APPLICATION INFORMATION

The UCC3819A is based on the UCC3818 PFC preregulator. For a more detailed application information for this part, please refer to the UCC3818 datasheet product folder.

The main difference between the UCC3818 and the UCC3819A is that the non-inverting input of the voltage error amplifier is made available to the user through an external pin (VAI) in the UCC3819A. The SS pin and function were eliminated to accommodate this change.

The benefit of VAI pin is that it can be used to dynamically change the PFC output voltage based on the line voltage (RMS) level or other conditions. Figure 1 shows one suggested implementation of the tracking boost PFC converter as this approach is sometimes referred to. The VAI pin is tied to the VFF pin and hence output voltage scales up with the line voltage. The benefit of this approach is that at lower line voltages the output voltage is lower and that leads to smaller boost inductor value, lower MOSFET conduction losses and reduced component stresses. In order for this feature to work, the downstream converter has to operate over a wider input range.

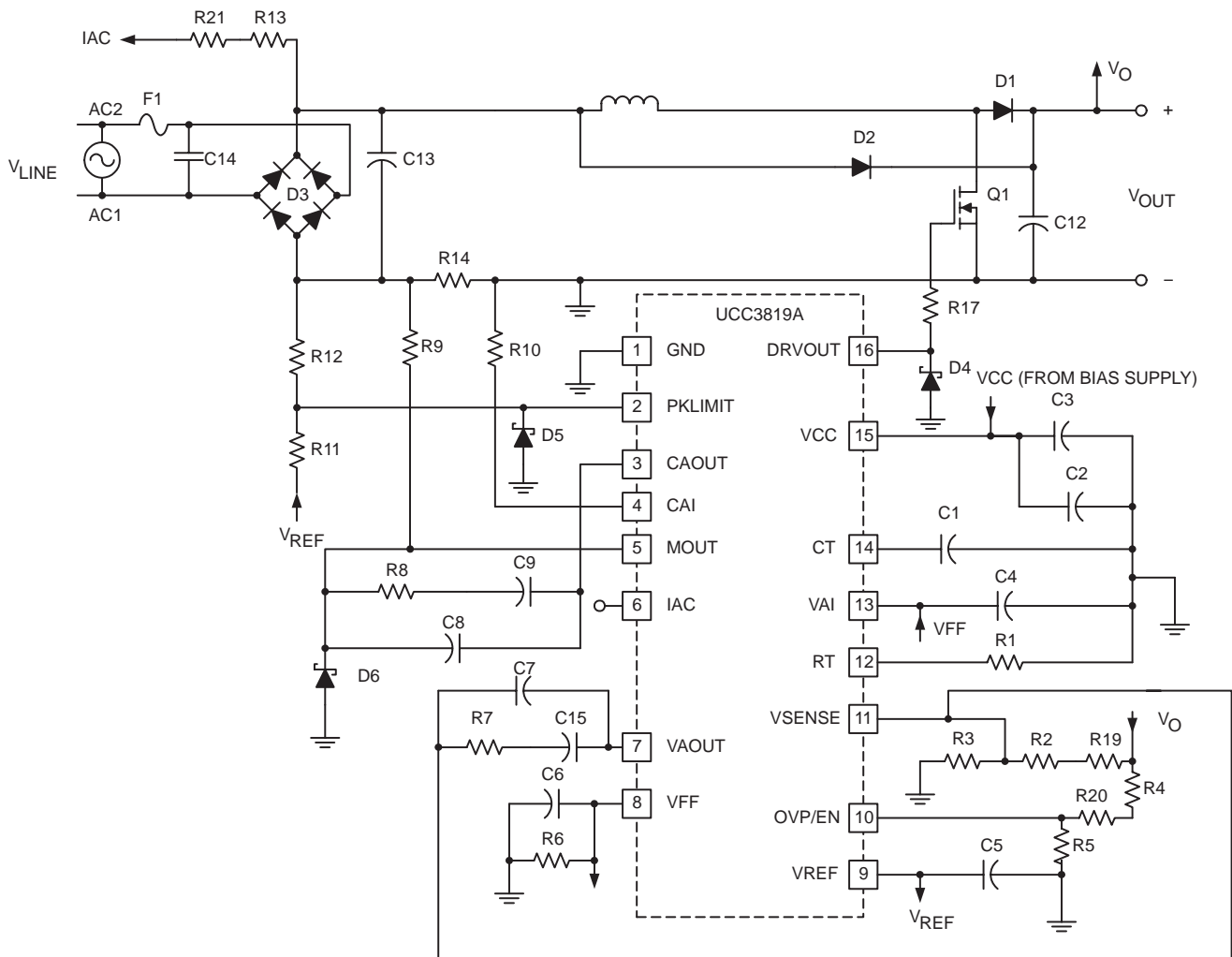

UDG-01008

Figure 1. Suggested Implementation of UCC3819A in a Tracking Boost PFC Preregulator



APPLICATION INFORMATION

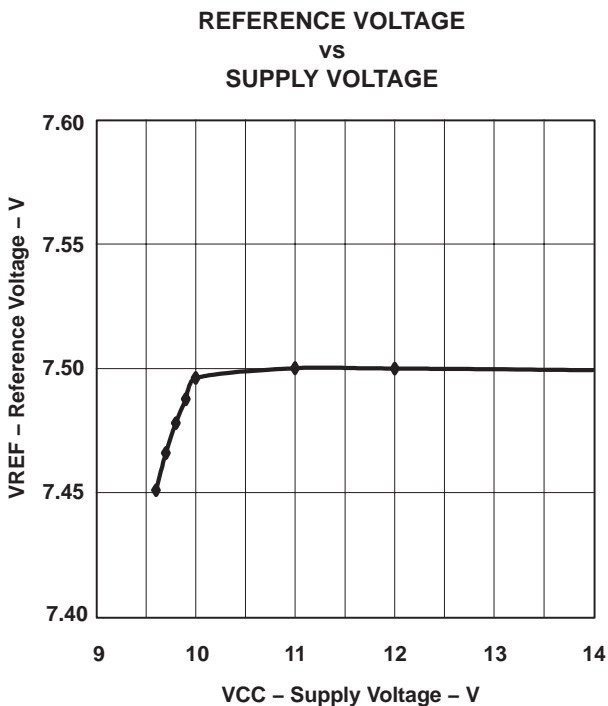

Figure 2

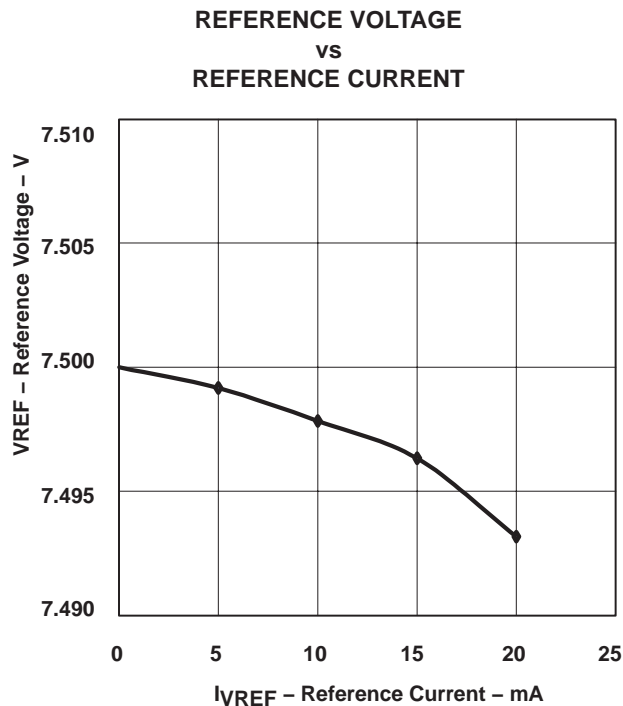

Figure 3

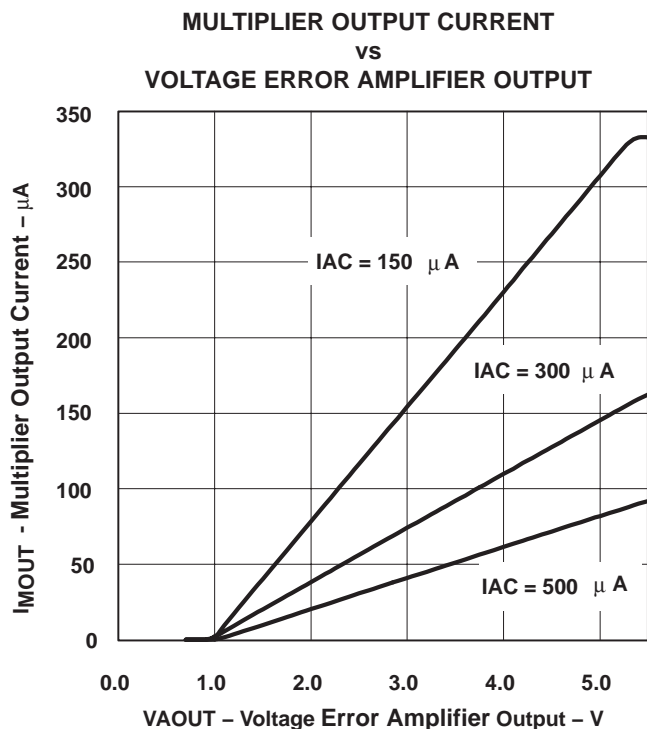

Figure 4

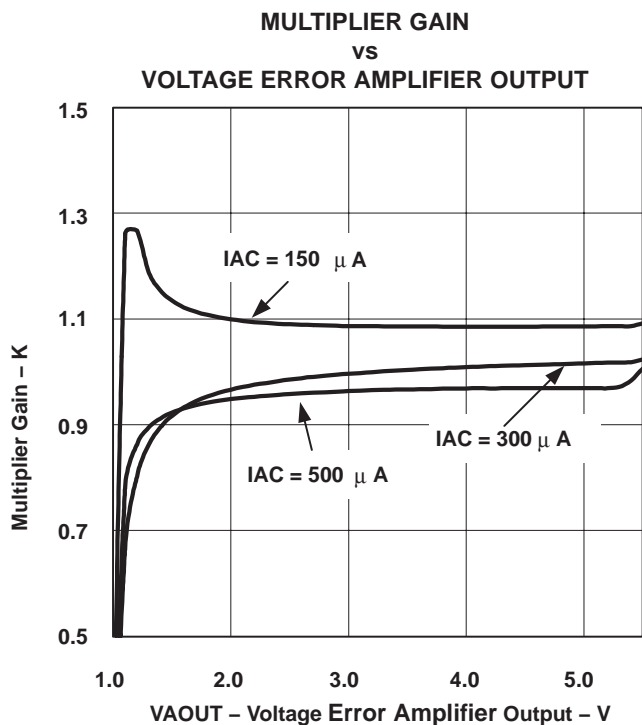
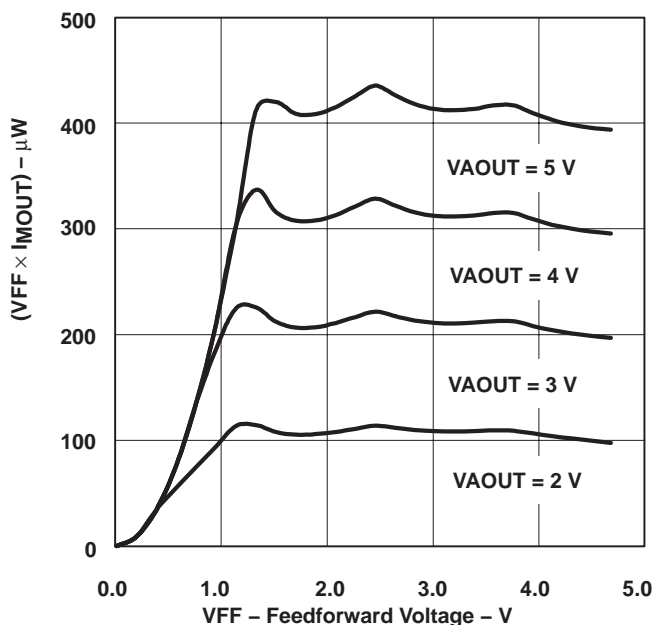

Figure 5

**APPLICATION INFORMATION**

**MULTIPLIER CONSTANT POWER PERFORMANCE**



**Figure 6**

**References and Resources:**

Application Note: *Differences Between UCC3817A/18A/19A and UCC3817/18/19*, Texas Instruments Literature Number SLUA294

User's Guide: *UCC3817 BiCMOS Power Factor Preregulator Evaluation Board*, Texas Instruments Literature Number SLUU077

Application Note: *Synchronizing a PFC Controller from a Down Stream Controller Gate Drive*, Texas Instruments Literature Number SLUA245

Seminar topic: *High Power Factor Switching Preregulator Design Optimization*, L.H. Dixon, SEM-700,1990.

Seminar topic: *High Power Factor Preregulator for Off-line Supplie*", L.H. Dixon, SEM-600, 1988.

**Related Products**

DEVICE	DESCRIPTION	CONTROL METHOD	TYPICAL POWER LEVEL
UCC3817/A,18/A	BiCMOS PFC controller	ACM(2)	75 W to 2 kW+
UC3854	PFC controller	ACM(2)	200 W to 2 kW+
UC3854A/B	Improved PFC controller	ACM(2)	200 W to 2 kW+
UC3855A/B	High performance soft switching PFC controller	ACM(2)	400 W to 2 kW+
UCC38050/1	Transition mode PFC controller	CRM(1)	50 W to 400 W
UCC28510/11/12/13	Advanced PFC+PWM combo controller	ACM(2)	75 W to 1kW+
UCC28514/15/16/17	Advanced PFC+PWM combo controller	ACM(2)	75 W to 1kW+

NOTES: (1). Critical conduction mode  
(2). Average current mode



**UCC2819A**  
**UCC3819A**

SLUS579 – OCTOBER, 2003

**MECHANICAL DATA**

**N (R-PDIP-T\*\*)**

**PLASTIC DUAL-IN-LINE PACKAGE**

16 PINS SHOWN

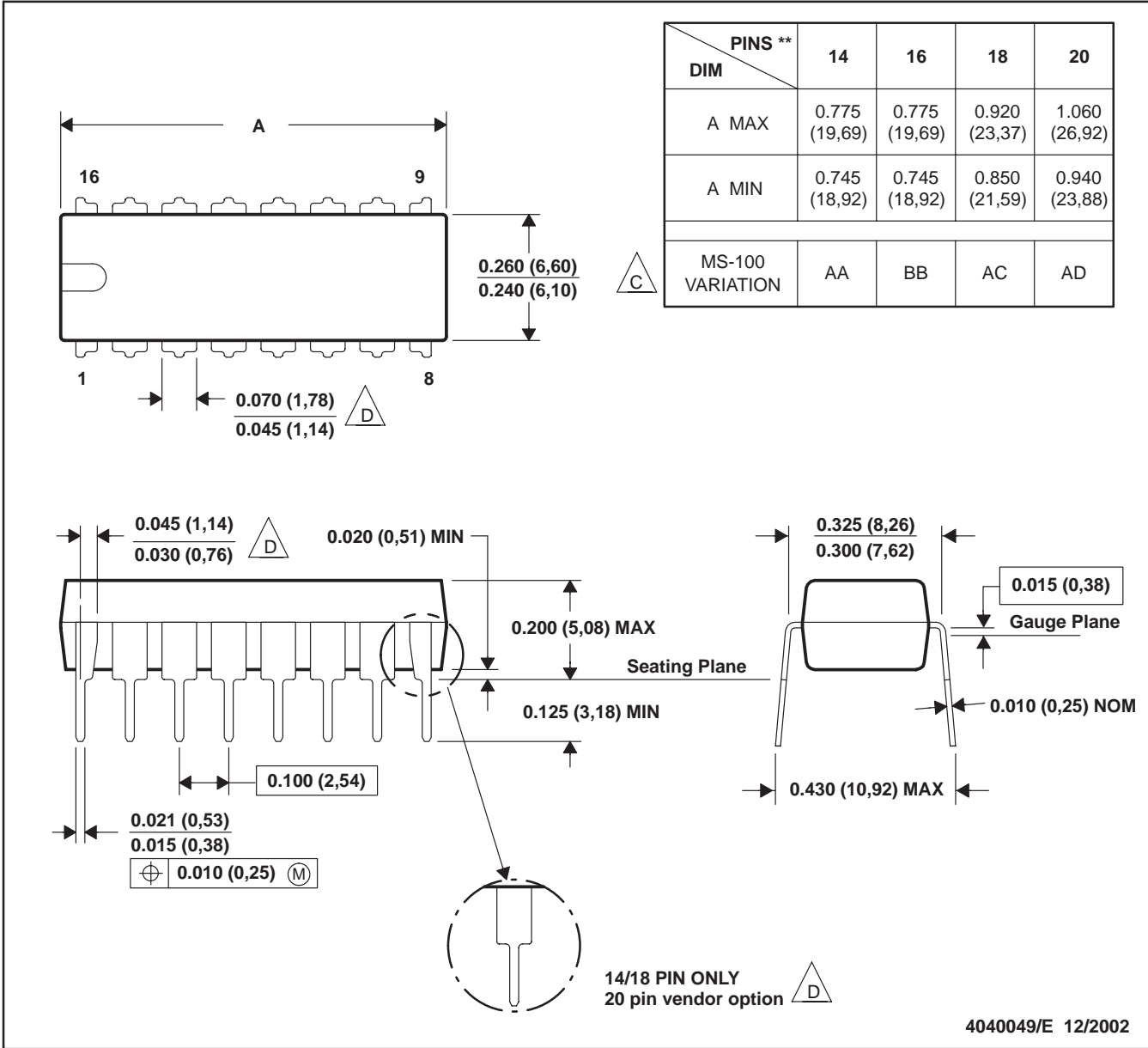

- NOTES: D. All linear dimensions are in inches (millimeters).  
 E. This drawing is subject to change without notice.  
 F. Falls within JEDEC MS-001, except 18 and 20 pin minimum body length (Dim A).  
 G. The 20 pin end lead shoulder width is a vendor option, either half or full width.

MECHANICAL DATA

PW (R-PDSO-G\*\*)

PLASTIC SMALL-OUTLINE PACKAGE

14 PINS SHOWN

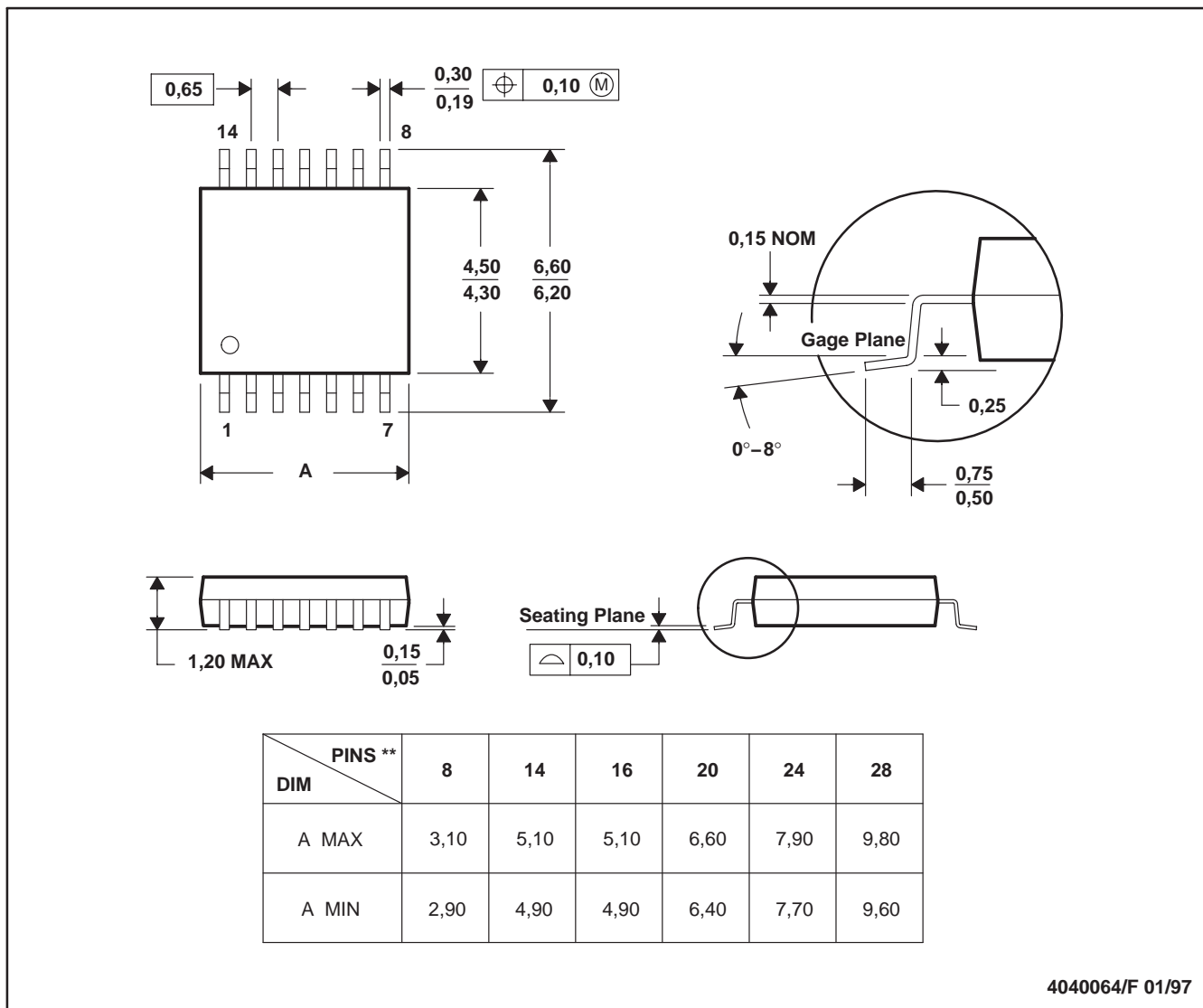

- NOTES: H. All linear dimensions are in millimeters.  
I. This drawing is subject to change without notice.  
J. Body dimensions do not include mold flash or protrusion not to exceed 0,15.

## PACKAGING INFORMATION

Orderable Device	Status <sup>(1)</sup>	Package Type	Package Drawing	Pins	Package Qty	Eco Plan <sup>(2)</sup>	Lead/Ball Finish	MSL Peak Temp <sup>(3)</sup>
UCC2819AD	ACTIVE	SOIC	D	16	40	Green (RoHS & no Sb/Br)	Call TI	Level-1-260C-UNLIM
UCC2819ADG4	ACTIVE	SOIC	D	16	40	Green (RoHS & no Sb/Br)	Call TI	Level-1-260C-UNLIM
UCC2819ADR	ACTIVE	SOIC	D	16	2500	Green (RoHS & no Sb/Br)	Call TI	Level-1-260C-UNLIM
UCC2819ADRG4	ACTIVE	SOIC	D	16	2500	Green (RoHS & no Sb/Br)	Call TI	Level-2-260C-1 YEAR
UCC2819AN	ACTIVE	PDIP	N	16	50	Green (RoHS & no Sb/Br)	CU NIPDAU	N / A for Pkg Type
UCC2819APW	ACTIVE	TSSOP	PW	16	90	Green (RoHS & no Sb/Br)	CU NIPDAU	Level-2-260C-1 YEAR
UCC2819APWG4	ACTIVE	TSSOP	PW	16	90	Green (RoHS & no Sb/Br)	CU NIPDAU	Level-2-260C-1 YEAR
UCC2819APWR	ACTIVE	TSSOP	PW	16	2000	Green (RoHS & no Sb/Br)	CU NIPDAU	Level-2-260C-1 YEAR
UCC2819APWRG4	ACTIVE	TSSOP	PW	16	2000	Green (RoHS & no Sb/Br)	CU NIPDAU	Level-2-260C-1 YEAR
UCC3819AD	ACTIVE	SOIC	D	16	40	Green (RoHS & no Sb/Br)	Call TI	Level-1-260C-UNLIM
UCC3819ADR	ACTIVE	SOIC	D	16	2500	Green (RoHS & no Sb/Br)	Call TI	Level-1-260C-UNLIM
UCC3819ADRG4	ACTIVE	SOIC	D	16	2500	Green (RoHS & no Sb/Br)	Call TI	Level-1-260C-UNLIM
UCC3819AN	ACTIVE	PDIP	N	16	25	Green (RoHS & no Sb/Br)	CU NIPDAU	N / A for Pkg Type
UCC3819APW	ACTIVE	TSSOP	PW	16	90	Green (RoHS & no Sb/Br)	CU NIPDAU	Level-2-260C-1 YEAR
UCC3819APWR	ACTIVE	TSSOP	PW	16	2000	Green (RoHS & no Sb/Br)	CU NIPDAU	Level-2-260C-1 YEAR
UCC3819APWRG4	ACTIVE	TSSOP	PW	16	2000	Green (RoHS & no Sb/Br)	CU NIPDAU	Level-2-260C-1 YEAR

<sup>(1)</sup> The marketing status values are defined as follows:

**ACTIVE:** Product device recommended for new designs.

**LIFEBUY:** TI has announced that the device will be discontinued, and a lifetime-buy period is in effect.

**NRND:** Not recommended for new designs. Device is in production to support existing customers, but TI does not recommend using this part in a new design.

**PREVIEW:** Device has been announced but is not in production. Samples may or may not be available.

**OBSOLETE:** TI has discontinued the production of the device.

<sup>(2)</sup> Eco Plan - The planned eco-friendly classification: Pb-Free (RoHS), Pb-Free (RoHS Exempt), or Green (RoHS & no Sb/Br) - please check <http://www.ti.com/productcontent> for the latest availability information and additional product content details.

**TBD:** The Pb-Free/Green conversion plan has not been defined.

**Pb-Free (RoHS):** TI's terms "Lead-Free" or "Pb-Free" mean semiconductor products that are compatible with the current RoHS requirements for all 6 substances, including the requirement that lead not exceed 0.1% by weight in homogeneous materials. Where designed to be soldered at high temperatures, TI Pb-Free products are suitable for use in specified lead-free processes.

**Pb-Free (RoHS Exempt):** This component has a RoHS exemption for either 1) lead-based flip-chip solder bumps used between the die and package, or 2) lead-based die adhesive used between the die and leadframe. The component is otherwise considered Pb-Free (RoHS compatible) as defined above.

**Green (RoHS & no Sb/Br):** TI defines "Green" to mean Pb-Free (RoHS compatible), and free of Bromine (Br) and Antimony (Sb) based flame retardants (Br or Sb do not exceed 0.1% by weight in homogeneous material)

(3) MSL, Peak Temp. -- The Moisture Sensitivity Level rating according to the JEDEC industry standard classifications, and peak solder temperature.

**Important Information and Disclaimer:**The information provided on this page represents TI's knowledge and belief as of the date that it is provided. TI bases its knowledge and belief on information provided by third parties, and makes no representation or warranty as to the accuracy of such information. Efforts are underway to better integrate information from third parties. TI has taken and continues to take reasonable steps to provide representative and accurate information but may not have conducted destructive testing or chemical analysis on incoming materials and chemicals. TI and TI suppliers consider certain information to be proprietary, and thus CAS numbers and other limited information may not be available for release.

In no event shall TI's liability arising out of such information exceed the total purchase price of the TI part(s) at issue in this document sold by TI to Customer on an annual basis.

# MECHANICAL DATA

## N (R-PDIP-T\*\*)

16 PINS SHOWN

## PLASTIC DUAL-IN-LINE PACKAGE

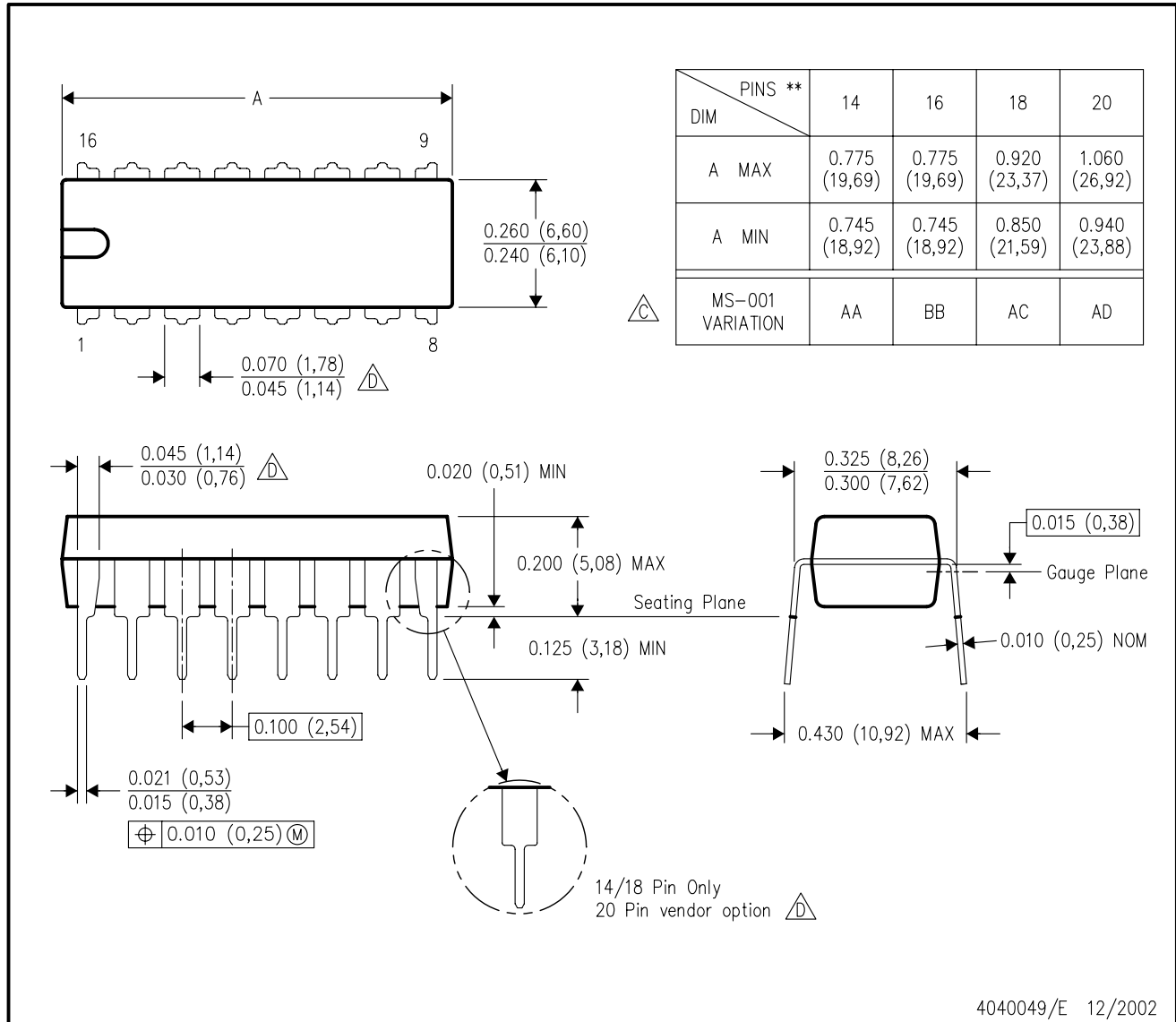

4040049/E 12/2002

- NOTES:
- A. All linear dimensions are in inches (millimeters).
  - B. This drawing is subject to change without notice.
  - $\triangle C$  Falls within JEDEC MS-001, except 18 and 20 pin minimum body length (Dim A).
  - $\triangle D$  The 20 pin end lead shoulder width is a vendor option, either half or full width.





# MECHANICAL DATA

MTSS001C – JANUARY 1995 – REVISED FEBRUARY 1999

**PW (R-PDSO-G\*\*)**

**PLASTIC SMALL-OUTLINE PACKAGE**

14 PINS SHOWN

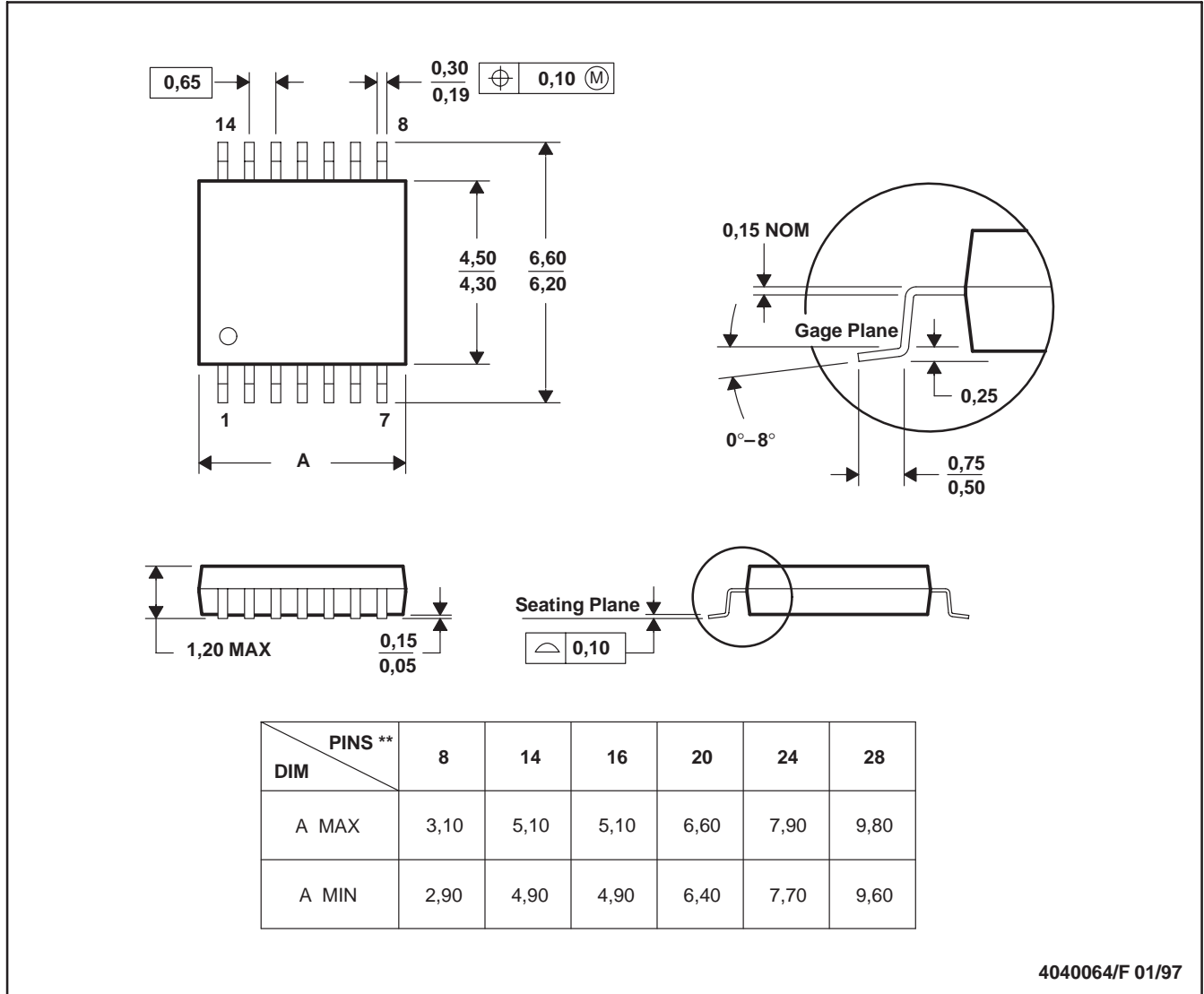

- NOTES: A. All linear dimensions are in millimeters.  
 B. This drawing is subject to change without notice.  
 C. Body dimensions do not include mold flash or protrusion not to exceed 0,15.  
 D. Falls within JEDEC MO-153

## IMPORTANT NOTICE

Texas Instruments Incorporated and its subsidiaries (TI) reserve the right to make corrections, modifications, enhancements, improvements, and other changes to its products and services at any time and to discontinue any product or service without notice. Customers should obtain the latest relevant information before placing orders and should verify that such information is current and complete. All products are sold subject to TI's terms and conditions of sale supplied at the time of order acknowledgment.

TI warrants performance of its hardware products to the specifications applicable at the time of sale in accordance with TI's standard warranty. Testing and other quality control techniques are used to the extent TI deems necessary to support this warranty. Except where mandated by government requirements, testing of all parameters of each product is not necessarily performed.

TI assumes no liability for applications assistance or customer product design. Customers are responsible for their products and applications using TI components. To minimize the risks associated with customer products and applications, customers should provide adequate design and operating safeguards.

TI does not warrant or represent that any license, either express or implied, is granted under any TI patent right, copyright, mask work right, or other TI intellectual property right relating to any combination, machine, or process in which TI products or services are used. Information published by TI regarding third-party products or services does not constitute a license from TI to use such products or services or a warranty or endorsement thereof. Use of such information may require a license from a third party under the patents or other intellectual property of the third party, or a license from TI under the patents or other intellectual property of TI.

Reproduction of information in TI data books or data sheets is permissible only if reproduction is without alteration and is accompanied by all associated warranties, conditions, limitations, and notices. Reproduction of this information with alteration is an unfair and deceptive business practice. TI is not responsible or liable for such altered documentation.

Resale of TI products or services with statements different from or beyond the parameters stated by TI for that product or service voids all express and any implied warranties for the associated TI product or service and is an unfair and deceptive business practice. TI is not responsible or liable for any such statements.

Following are URLs where you can obtain information on other Texas Instruments products and application solutions:

<b>Products</b>		<b>Applications</b>	
Amplifiers	<a href="http://amplifier.ti.com">amplifier.ti.com</a>	Audio	<a href="http://www.ti.com/audio">www.ti.com/audio</a>
Data Converters	<a href="http://dataconverter.ti.com">dataconverter.ti.com</a>	Automotive	<a href="http://www.ti.com/automotive">www.ti.com/automotive</a>
DSP	<a href="http://dsp.ti.com">dsp.ti.com</a>	Broadband	<a href="http://www.ti.com/broadband">www.ti.com/broadband</a>
Interface	<a href="http://interface.ti.com">interface.ti.com</a>	Digital Control	<a href="http://www.ti.com/digitalcontrol">www.ti.com/digitalcontrol</a>
Logic	<a href="http://logic.ti.com">logic.ti.com</a>	Military	<a href="http://www.ti.com/military">www.ti.com/military</a>
Power Mgmt	<a href="http://power.ti.com">power.ti.com</a>	Optical Networking	<a href="http://www.ti.com/opticalnetwork">www.ti.com/opticalnetwork</a>
Microcontrollers	<a href="http://microcontroller.ti.com">microcontroller.ti.com</a>	Security	<a href="http://www.ti.com/security">www.ti.com/security</a>
		Telephony	<a href="http://www.ti.com/telephony">www.ti.com/telephony</a>
		Video & Imaging	<a href="http://www.ti.com/video">www.ti.com/video</a>
		Wireless	<a href="http://www.ti.com/wireless">www.ti.com/wireless</a>

Mailing Address: Texas Instruments  
Post Office Box 655303 Dallas, Texas 75265