

POSITIVE AND NEGATIVE OUTPUT DC-DC CONVERTER

FEATURES

- Dual Adjustable Output Voltages Up to +15 V and Down to –15 V
- 800-mA Typical Switch Current Limit at Boost and Inverter Main Switches at TPS65130
- 2-A Typical Switch Current Limit at Boost and Inverter Main Switches at TPS65131
- Up to 89% Efficiency at Positive Output Voltage Rail
- Up to 81% Efficiency at Negative Output Voltage Rail
- Power-Save Mode for High Efficiency at Low Load Currents
- Independent Enable Inputs for Power Up and Power Down Sequencing
- Control Output for External PFET to Support Completely Disconnecting the Battery
- 2.7-V to 5.5-V Input Voltage Range
- Minimum 1.25-MHz Fixed Frequency PWM Operation
- Thermal Shutdown
- Overvoltage Protection on Both Outputs
- 1- μ A Shutdown Current
- Small 4 mm x 4 mm QFN-24 Package (RGE)

APPLICATIONS

- Small to Medium Size OLED Displays
- (TFT) LCD and CCD Bias Supply
- PDAs, Pocket PCs, Smartphones
- Digital Cameras
- Camcorders

DESCRIPTION

The TPS65130/1 is dual-output dc-dc converter generating a positive output voltage up to 15 V and a negative output voltage down to -15 V with output currents in a 200-mA range in typical applications, depending on input voltage to output voltage ratio. With a total efficiency up to 85%, the device is ideal for portable battery-powered equipment. The input voltage range of 2.7 V to 5.5 V allows the TPS65130/1 to be directly powered from a Li-ion battery, from 3 cells NiMH/NiCd or alkaline batteries. The TPS65130/1 comes in a small 4 mm x 4 mm QFN-24 package. Together with a minimum switching frequency of 1.25 MHz it enables designing small power supply applications because it requires only a few small external components.

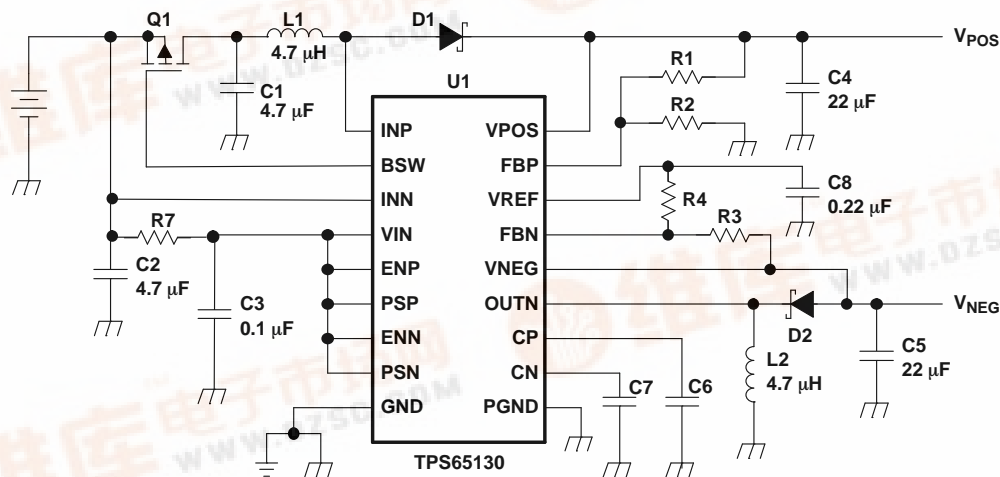

Please be aware that an important notice concerning availability, standard warranty, and use in critical applications of Texas Instruments semiconductor products and disclaimers thereto appears at the end of this data sheet.

PowerPAD is a trademark of Texas Instruments.



This integrated circuit can be damaged by ESD. Texas Instruments recommends that all integrated circuits be handled with appropriate precautions. Failure to observe proper handling and installation procedures can cause damage.

ESD damage can range from subtle performance degradation to complete device failure. Precision integrated circuits may be more susceptible to damage because very small parametric changes could cause the device not to meet its published specifications.

DESCRIPTION (CONTINUED)

The converter operates with a fixed frequency PWM control topology and, if power-save mode is enabled, it uses a pulse-skipping mode at light load currents. It operates with only 500-µA device quiescent current. Independent enable pins allow power up and power down sequencing for both outputs. The device has an internal current limit overvoltage protection and a thermal shutdown for highest reliability under fault conditions.

ORDERING INFORMATION

T _A	SWITCH CURRENT LIMIT		PART NUMBER ⁽¹⁾
	BOOST CONVERTER	INVERTING CONVERTER	
-40°C to 85°C	800 mA	800 mA	TPS65130RGE
-40°C to 85°C	1950 mA	1950 mA	TPS65131RGE

- (1) The RGE package is available taped and reeled. Add an R suffix to the device type (i.e., TPS65130RGER) to order quantities of 3000 devices per reel. It is also available in minireels. Add a T suffix to the device type (i.e., TPS65130RGET) to order quantities of 250 devices per reel.

ABSOLUTE MAXIMUM RATINGS

over operating free-air temperature range unless otherwise noted⁽¹⁾

		TPS65130/1
V _{IN} , I _{NN}	Input voltage range at pins ⁽²⁾	-0.3 V to +6.0 V
V _{POS}	Maximum voltage at pin ⁽²⁾	17 V
V _{NEG}	Minimum voltage at pin ⁽²⁾	-17 V
	Voltage at pins ENN, ENP, FBP, FBN, CN, CP, PSP, PSN, BSW ⁽²⁾	-0.3 V to V _{IN} + 0.3 V
I _{NP}	Input voltage at pin ⁽²⁾	17 V
	Differential voltage between pins OUTN to V _{INN} ⁽²⁾	24 V
T _J	Operating virtual junction temperature	-40°C to 150°C
T _{STG}	Storage temperature range	-65°C to 150°C

- (1) Stresses beyond those listed under "absolute maximum ratings" may cause permanent damage to the device. These are stress ratings only, and functional operation of the device at these or any other conditions beyond those indicated under "recommended operating conditions" is not implied. Exposure to absolute-maximum-rated conditions for extended periods may affect device reliability.
 (2) All voltage values are with respect to network ground terminal, unless otherwise noted.

DISSIPATION RATINGS TABLE ⁽¹⁾

PACKAGE	Θ _{JA}	Θ _{JB}	Θ _{JC}	T _A ≤ 25°C POWER RATING	DERATING FACTOR ABOVE T _A = 25°C	T _A = 70°C POWER RATING	T _A = 85°C POWER RATING
RGE	37.8 °C/W	27.8 °C/W	57.9 °C/W	2646 mW	26 mW/°C	1455 mW	1058 mW

- (1) This thermal data is based on assembly of the device on a JEDEC high K board. The PowerPAD must be soldered on a pad on the board. There must be vias within the pad that contact the ground plane in the PCB. Exceeding the maximum junction temperature will force the device into thermal shutdown.

RECOMMENDED OPERATING CONDITIONS

		MIN	NOM	MAX	UNIT
V_I	Input voltage range	2.7		5.5	V
T_A	Operating free-air temperature range	-40		85	°C
T_J	Operating virtual junction temperature range	-40		125	°C

ELECTRICAL CHARACTERISTICS

Over recommended free-air temperature range and over recommended input voltage range, typical at an ambient temperature of 25°C (unless otherwise noted)

PARAMETER		TEST CONDITIONS	MIN	TYP	MAX	UNIT
DC-DC STAGE (V_{POS}, V_{NEG})						
V_{POS}	Adjustable output voltage range		$V_{IN} + 0.5$ V		15	V
V_{NEG}	Adjustable output voltage range		-15		-2	V
V_{REF}	Reference voltage	$I_{REF} = 10 \mu A$	1.2	1.213	1.225	V
I_{FBP}	Positive feedback input bias current	$V_{FBP} = V_{REF}$		50		nA
I_{FBN}	Negative feedback input bias current	$V_{FBN} = 0.1 V_{REF}$		50		nA
V_{FBP}	Positive feedback regulation voltage	$V_{IN} = 2.7$ V to 5.5 V	1.189	1.213	1.237	V
V_{FBN}	Negative feedback regulation voltage	$V_{IN} = 2.7$ V to 5.5 V	-0.024	0	0.024	V
	Total Output DC accuracy			+3%		
$R_{DS(ONN)}$	Inverter switch on-resistance	$V_{IN} = 3.6$ V		440	620	mΩ
		$V_{IN} = 5.0$ V		330	530	
I_{LIMN}	TPS65130 Inverter switch current limit	2.7 V < V_{IN} < 5.5 V	700	800	900	mA
I_{LIM}	TPS65131 Inverter switch current limit	$V_{IN} = 3.6$ V	1800	1950	2200	mA
$R_{DS(ONP)}$	Boost switch on-resistance	$V_{POS} = 5$ V		230	300	mΩ
		$V_{POS} = 10$ V		170	200	
I_{LIMP}	TPS65130 Boost switch current limit	2.7 V < V_{IN} < 5.5 V	700	800	900	mA
I_{LIMP}	TPS65131 Boost switch current limit	$V_{IN} = 3.6$ V, $V_{POS} = 8.0$ V	1800	1950	2200	mA
D_{MAXP}	Maximum duty cycle boost converter			87.5%		
D_{MAXN}	Maximum duty cycle inverting converter			87.5%		
D_{MINP}	Minimum duty cycle boost converter			12.5%		
D_{MINN}	Minimum duty cycle inverting converter			12.5%		
CONTROL STAGE						
f_S	Oscillator frequency		1250	1380	1500	kHz
$V_{ENP,ENN,PSP,PSN}$	High level input voltage		1.4			V
$V_{ENP,ENN,PSP,PSN}$	Low level input voltage				0.4	V
$I_{ENP,ENN,PSP,PSN}$	Input current	ENP, ENN, PSP, PSN = GND or VIN		0.01	0.1	μA
R_{BSW}	Output resistance			27		kΩ
V_{IN}	Input voltage range		2.7		5.5	V

ELECTRICAL CHARACTERISTICS (continued)

Over recommended free-air temperature range and over recommended input voltage range, typical at an ambient temperature of 25°C (unless otherwise noted)

PARAMETER		TEST CONDITIONS	MIN	TYP	MAX	UNIT	
$I_{(Q)}$	Quiescent current	VIN	$V_{IN} = 3.6\text{ V}$, $I_{OUTP} = I_{OUTN} = 0$, ENP = ENN = PSP = PSN = V_{IN} , $V_{POS} = 8\text{ V}$, $V_{NEG} = -5\text{ V}$		300	500	μA
		VPOS			100	120	μA
		VNEG			100	120	μA
I_{SD}	Shutdown supply current	ENN = ENP = GND		0.2	1.5	μA	
V_{UVLO}	Undervoltage lockout threshold		2.1	2.35	2.7	V	
	Thermal shutdown			150		$^{\circ}\text{C}$	
	Thermal shutdown hysteresis	Junction temperature decreasing		5		$^{\circ}\text{C}$	

PIN ASSIGNMENTS

HTTSOP PowerPAD™
(TOP VIEW)

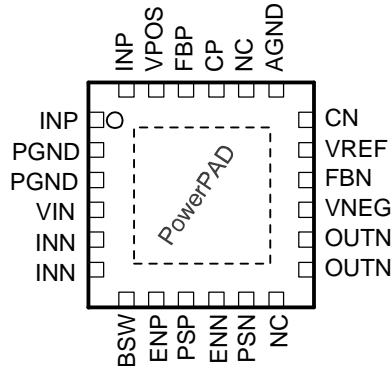

NC – No internal connection

Terminal Functions

TERMINAL NAME	NO.	I/O	DESCRIPTION
INP	1, 24	I	Boost converter switch input.
INN	5, 6	I	Inverting converter switch input
PGND	2, 3		Power ground pin
AGND	19		Analog ground pin
ENN	10	I	Enable pin for the negative output voltage (0 V: disabled, VIN: enabled)
ENP	8	I	Enable pin for the positive output voltage (0 V: disabled, VIN: enabled)
FBN	16	I	Feedback pin for the negative output voltage divider
FBP	22	I	Feedback pin for the positive output voltage divider
OUTN	13, 14	O	Inverting converter switch output.
VREF	17	O	Reference output voltage. Bypass this pin with a 220-nF capacitor to ground. Connect the lower resistor of the negative output voltage divider to this pin
CP	21		Compensation pin for boost converter control
CN	18		Compensation pin for inverting converter control
VIN	4	I	Control supply input
VPOS	23	I	Positive output voltage sense input
VNEG	15	I	Negative output voltage sense input

PIN ASSIGNMENTS (continued)

Terminal Functions (continued)

TERMINAL NAME	NO.	I/O	DESCRIPTION
PSP	9	I	Power-save mode enable for boost converter stage (0 V: disabled, VIN: enabled)
PSN	11	I	Power-save mode enable for inverter stage (0 V: disabled, VIN: enabled)
BSW	7	O	Gate control pin for external battery switch. This pin goes low when ENP is set high.
NC	12, 20		Not connected

FUNCTIONAL BLOCK DIAGRAM

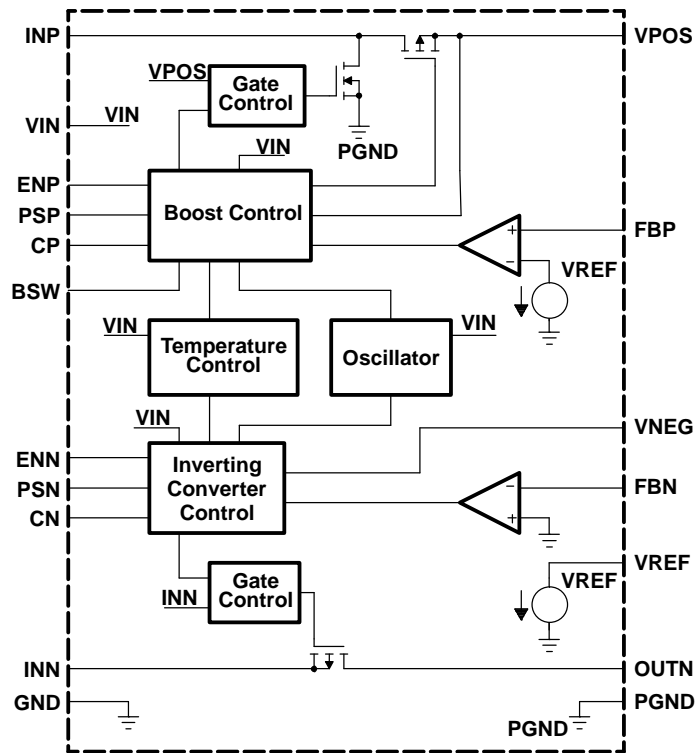

TYPICAL CHARACTERISTICS

PARAMETER MEASUREMENT INFORMATION

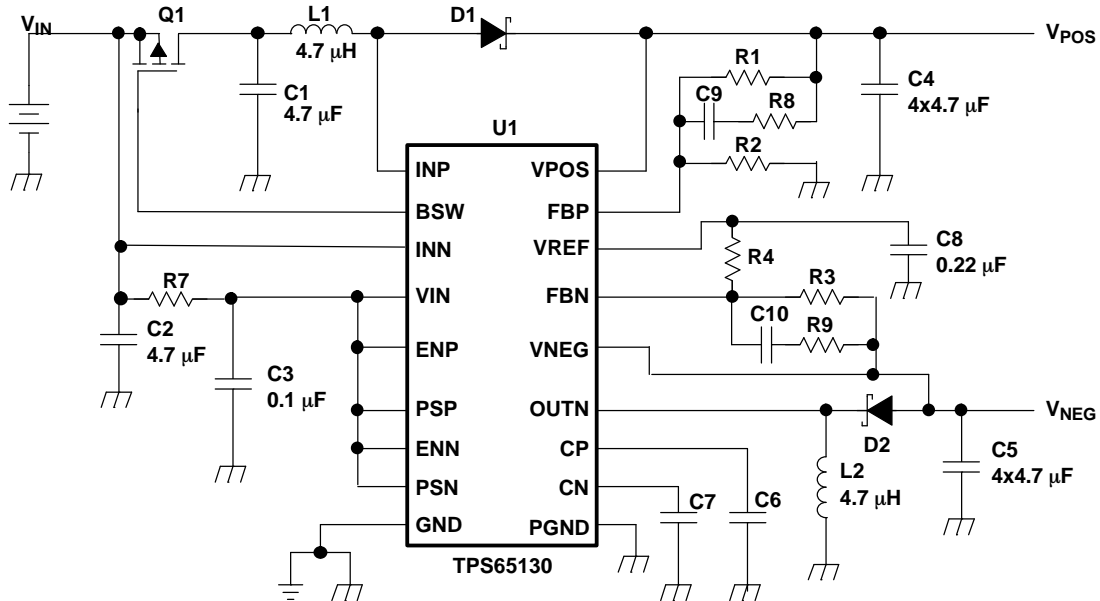

List of Components

REFERENCE	DESCRIPTION
C1, C2	X7R/X5R ceramic
C4, C5	4x4.7 μ F X7R/X5R ceramic
D1, D2	MBRM120
L1, L2	Würth Elektronik 7447789004 (TPS65130), EPCOS B82462-G4472 (TPS65131)

PERFORMANCE GRAPHS

Table of Graphs

GRAPH	DESCRIPTION
Figure 1	TPS65130 maximum output current versus input voltage, $V_{POS} = 12\text{ V}, 8\text{ V}, 5\text{ V}$
Figure 2	TPS65131 maximum output current versus input voltage, $V_{POS} = 15\text{ V}, 10\text{ V}, 5\text{ V}$
Figure 3	TPS65130 maximum output current versus input voltage, $V_{NEG} = -4\text{ V}, -8\text{ V}, -10\text{ V}$
Figure 4	TPS65131 maximum output current versus input voltage, $V_{NEG} = -4\text{ V}, -10\text{ V}, -15\text{ V}$
Figure 5	TPS65130 efficiency versus output current, $V_{POS} = 5\text{ V}$
Figure 6	TPS65131 efficiency versus output current, $V_{POS} = 5\text{ V}$
Figure 7	TPS65130 efficiency versus output current, $V_{POS} = 8\text{ V}$
Figure 8	TPS65131 efficiency versus output current, $V_{POS} = 10\text{ V}$
Figure 9	TPS65130 efficiency versus output current, $V_{POS} = 12\text{ V}$
Figure 10	TPS65131 efficiency versus output current, $V_{POS} = 15\text{ V}$
Figure 11	TPS65130 efficiency versus output current, $V_{NEG} = -4\text{ V}, (V_{IN} = 4\text{ V}, 3\text{ V})$
Figure 12	TPS65131 efficiency versus output current, $V_{NEG} = -4\text{ V}, (V_{IN} = 5\text{ V}, 3\text{ V})$
Figure 13	TPS65130 efficiency versus output current, $V_{NEG} = -8\text{ V}, (V_{IN} = 4.2\text{ V}, 3\text{ V})$
Figure 14	TPS65131 efficiency versus output current, $V_{NEG} = -10\text{ V}, (V_{IN} = 5\text{ V}, 3\text{ V})$
Figure 15	TPS65130 efficiency versus output current, $V_{NEG} = -10\text{ V}, (V_{IN} = 4.2\text{ V}, 3\text{ V})$

Table of Graphs (continued)

GRAPH	DESCRIPTION
Figure 16	TPS65131 efficiency versus output current, $V_{NEG} = -15\text{ V}$, ($V_{IN} = 5\text{ V}, 3\text{ V}$)
Figure 17	TPS65130 efficiency versus input voltage, $V_{POS} = 5\text{ V}$ in power-save mode
Figure 18	TPS65130 efficiency versus input voltage, $V_{POS} = 8\text{ V}$ in power-save mode
Figure 19	TPS65130 efficiency versus input voltage, $V_{POS} = 12\text{ V}$ in power-save mode
Figure 20	TPS65130 efficiency versus input voltage, $V_{NEG} = -4\text{ V}$ in power-save mode
Figure 21	TPS65130 efficiency versus input voltage, $V_{NEG} = -8\text{ V}$ in power-save mode
Figure 22	TPS65130 efficiency versus input voltage, $V_{NEG} = -10\text{ V}$ in power-save mode
Figure 23	TPS65130 efficiency versus output current, $V_O = 13.5\text{ V}$ (+9 V, -4.5 V), ($V_{IN} = 4.2\text{ V}, 3\text{ V}$)
Figure 24	TPS65131 efficiency versus output current, $V_O = 30\text{ V}$ ($\pm 15\text{ V}$, ($V_{IN} = 5\text{ V}, 3\text{ V}$))
Figure 25	TPS65130 efficiency versus input voltage, $V_O = 13.5\text{ V}$ (9 V, -4.5 V) in power save mode
Figure 26	TPS65130 output voltage versus output current, $V_{POS} = 5\text{ V}$, $V_{IN} = 3\text{ V}$
Figure 27	TPS65131 output voltage versus output current, $V_{POS} = 5\text{ V}$, $V_{IN} = 4.2\text{ V}$
Figure 28	TPS65130 output voltage versus output current, $V_{POS} = 8\text{ V}$, $V_{IN} = 3\text{ V}$
Figure 29	TPS65131 output voltage versus output current, $V_{POS} = 10\text{ V}$, $V_{IN} = 5\text{ V}$
Figure 30	TPS65130 output voltage versus output current, $V_{POS} = 12\text{ V}$ ($V_{IN} = 3\text{ V}$)
Figure 31	TPS65131 output voltage versus output current, $V_{POS} = 15\text{ V}$ ($V_{IN} = 5\text{ V}$)
Figure 32	TPS65130 output voltage versus output current, $V_{NEG} = -4\text{ V}$, $V_{IN} = 3\text{ V}$
Figure 33	TPS65131 output voltage versus output current, $V_{NEG} = -4\text{ V}$, $V_{IN} = 5\text{ V}$
Figure 34	TPS65130 output voltage versus output current, $V_{NEG} = -8\text{ V}$, $V_{IN} = 3\text{ V}$
Figure 35	TPS65131 output voltage versus output current, $V_{NEG} = -10\text{ V}$, $V_{IN} = 5\text{ V}$
Figure 36	TPS65130 output voltage versus output current, $V_{NEG} = -10\text{ V}$, $V_{IN} = 3\text{ V}$
Figure 37	TPS65131 output voltage versus output current, $V_{NEG} = -15\text{ V}$, $V_{IN} = 5\text{ V}$
Figure 38	No load supply current into V_{IN} versus input voltage
Figure 39	No load supply current into V_{POS} versus input voltage
Figure 40	No load supply current into V_{NEG} versus input voltage
Figure 41	Positive output voltage in continuous current mode
Figure 42	Negative output voltage in continuous current mode
Figure 43	Positive output voltage at power-save mode disabled
Figure 44	Negative output voltage at power-save mode disabled
Figure 45	Positive output voltage in power-save mode, $V_I = 3.6\text{ V}$, $V_{POS} = 5.5\text{ V}$
Figure 46	Negative output voltage in power-save mode, $V_I = 3.6\text{ V}$, $V_{NEG} = -8\text{ V}$
Figure 47	Load transient response, $V_I = 3.6\text{ V}$, $V_{POS} = 8\text{ V}$
Figure 48	Load transient response, $V_I = 3.6\text{ V}$, $V_{NEG} = -8\text{ V}$
Figure 49	Line transient response, $V_I = 3.6\text{ V}$ to 4.2 V , $V_{POS} = 8\text{ V}$
Figure 50	Line transient response, $V_I = 3.6\text{ V}$ to 4.2 V , $V_{NEG} = -8\text{ V}$
Figure 51	Start-up after enable, $V_{POS} = 8\text{ V}$, $V_I = 3.6\text{ V}$
Figure 52	Start-up after enable, $V_{NEG} = -8\text{ V}$, $V_I = 3.6\text{ V}$

TYPICAL CHARACTERISTICS

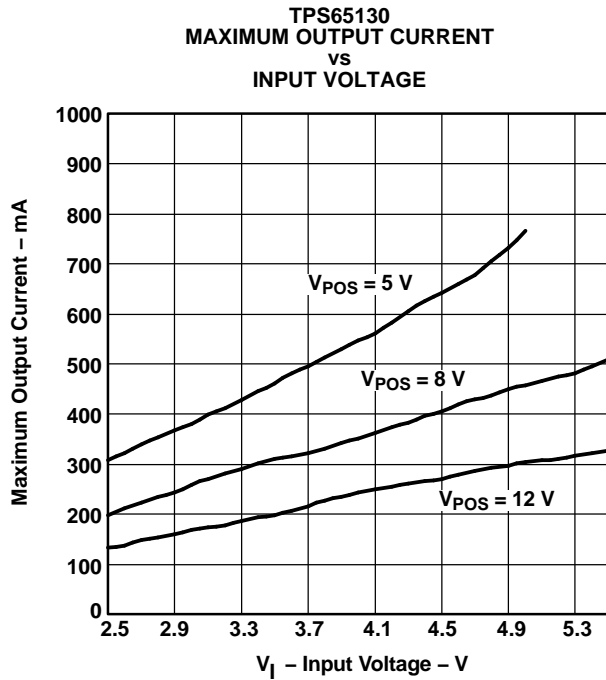

Figure 1.

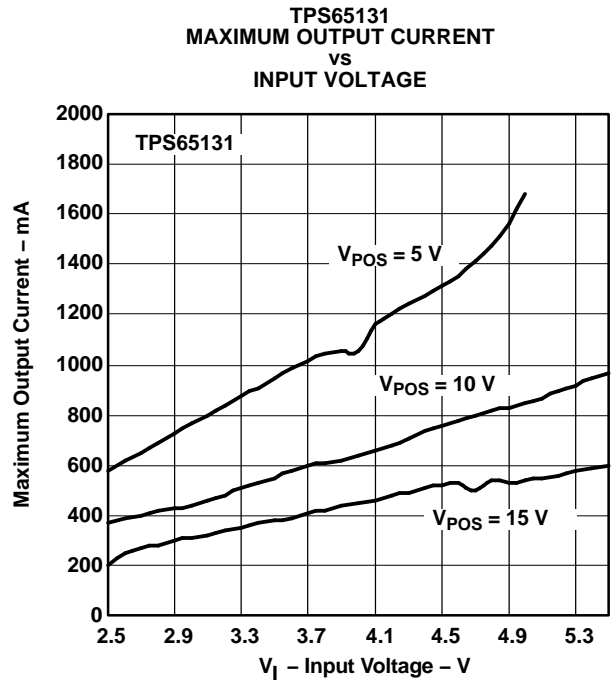

Figure 2.

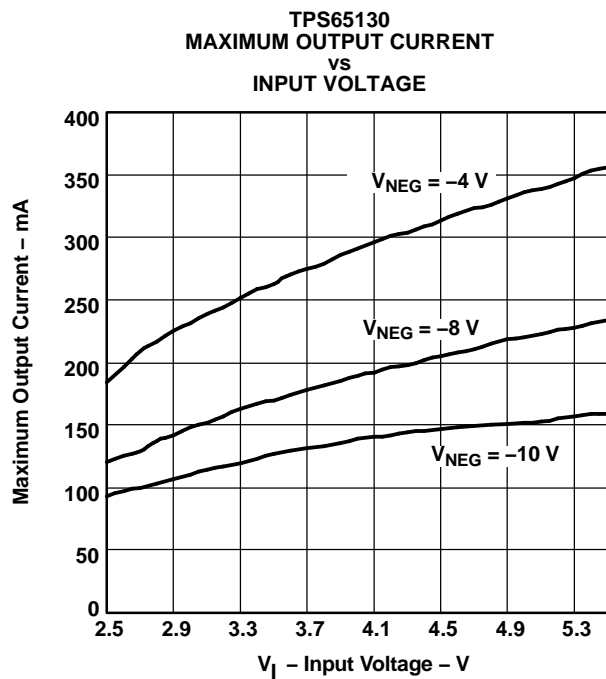

Figure 3.

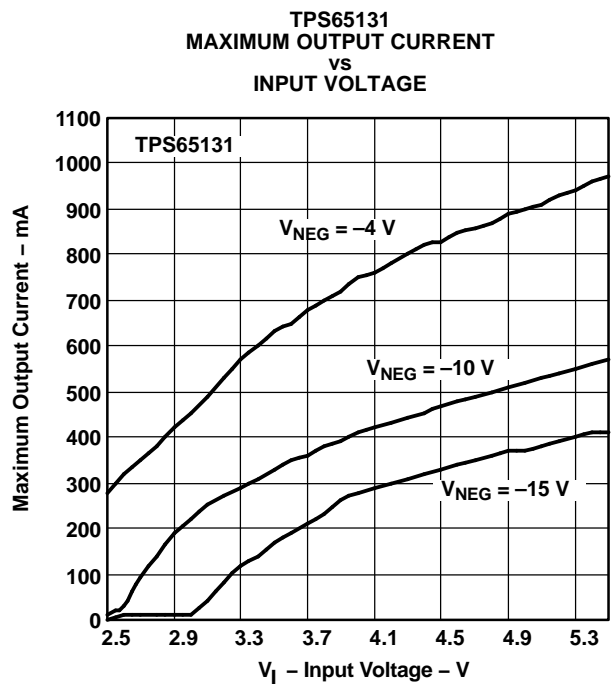

Figure 4.

TYPICAL CHARACTERISTICS (continued)

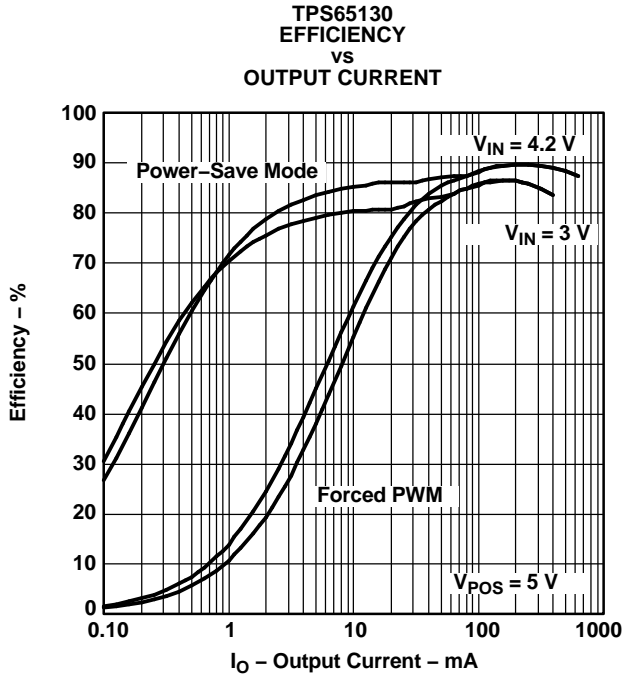

Figure 5.

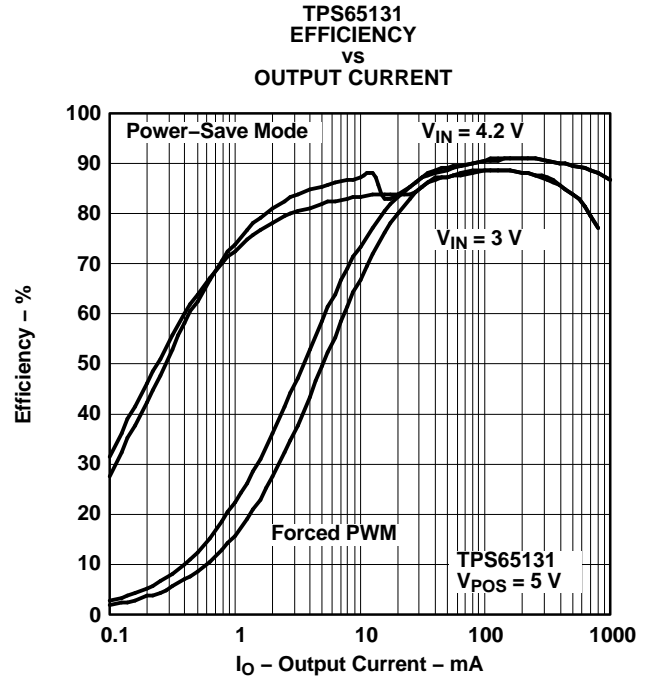

Figure 6.

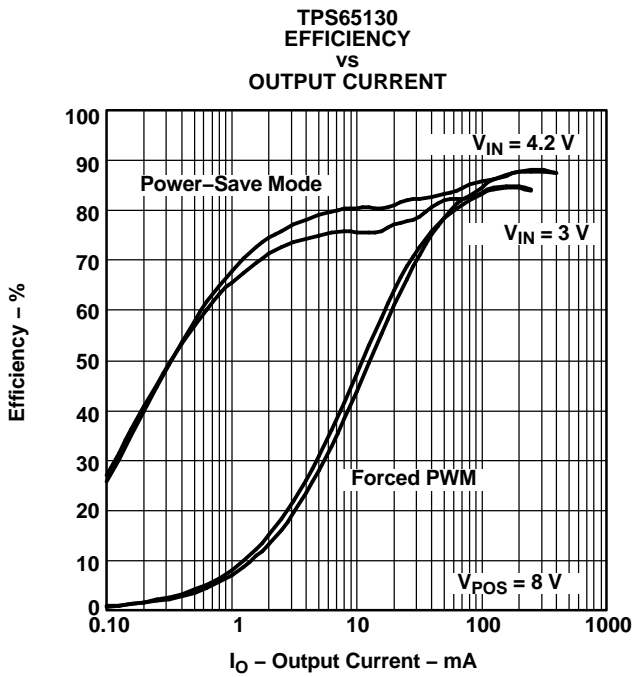

Figure 7.

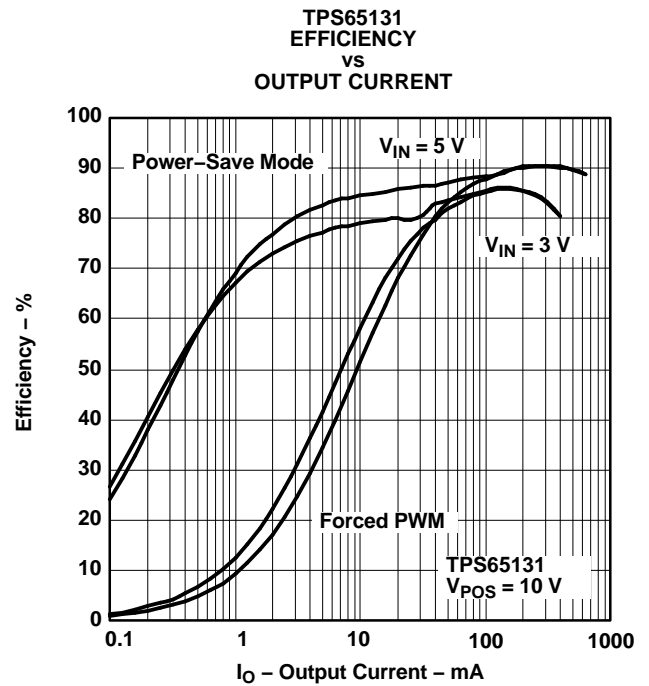

Figure 8.

TYPICAL CHARACTERISTICS (continued)

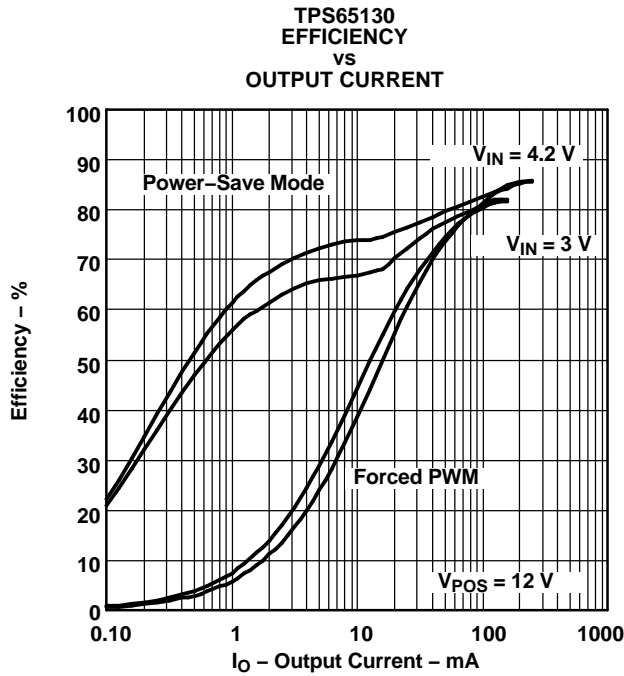

Figure 9.

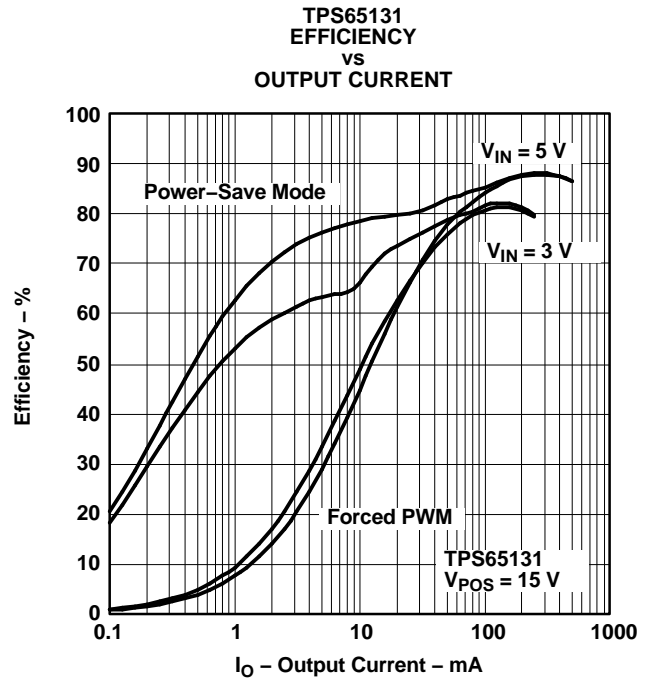

Figure 10.

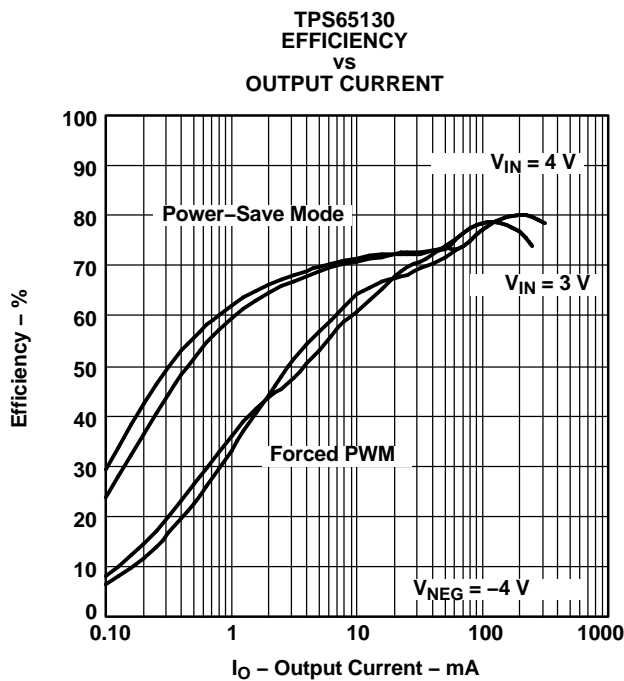

Figure 11.

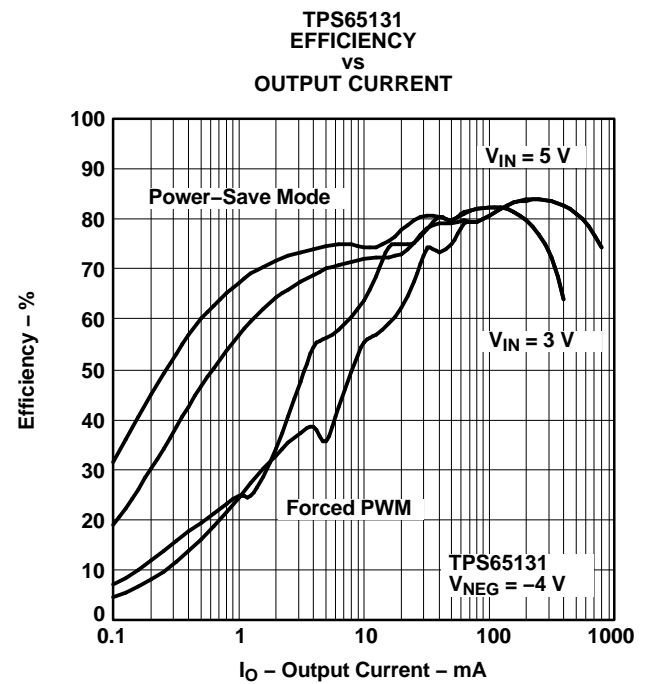

Figure 12.

TYPICAL CHARACTERISTICS (continued)

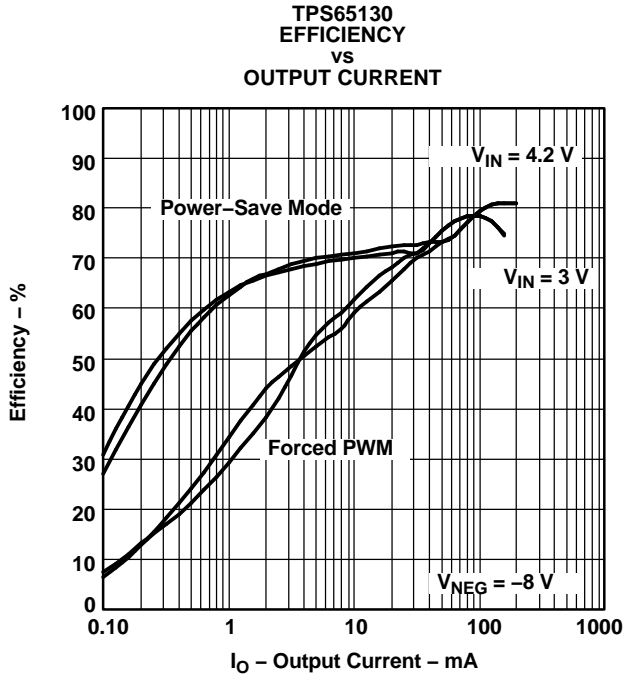

Figure 13.

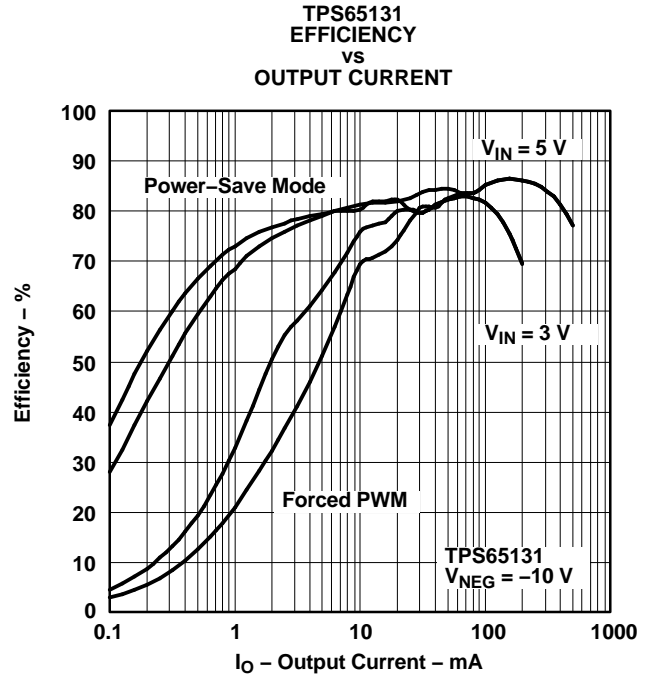

Figure 14.

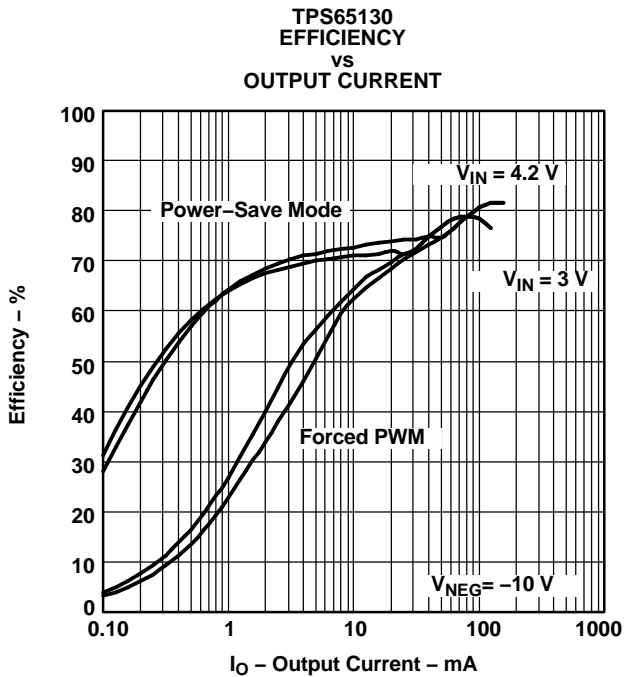

Figure 15.

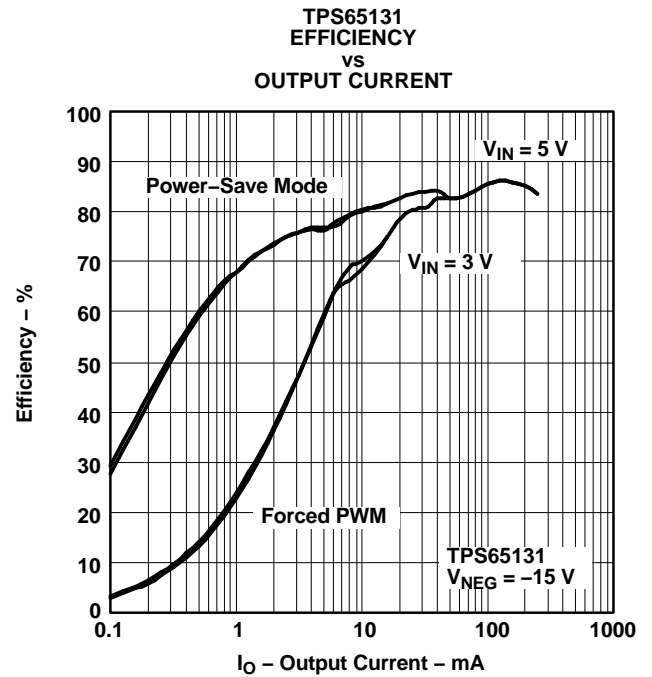

Figure 16.

TYPICAL CHARACTERISTICS (continued)

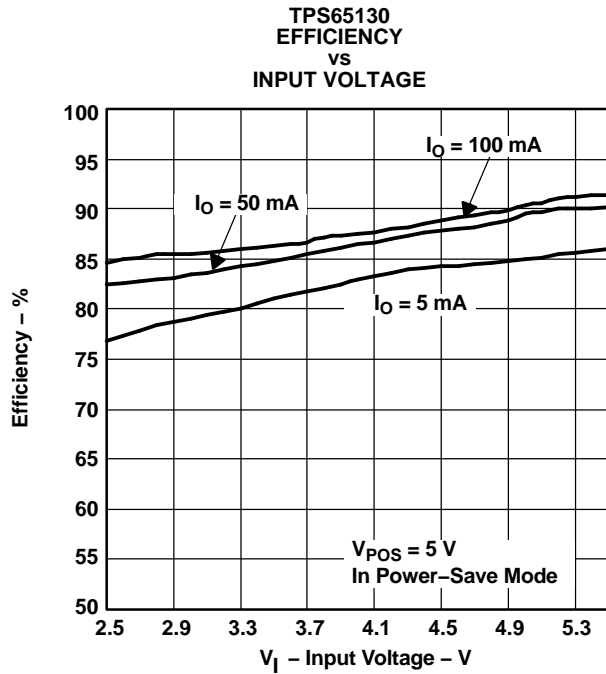

Figure 17.

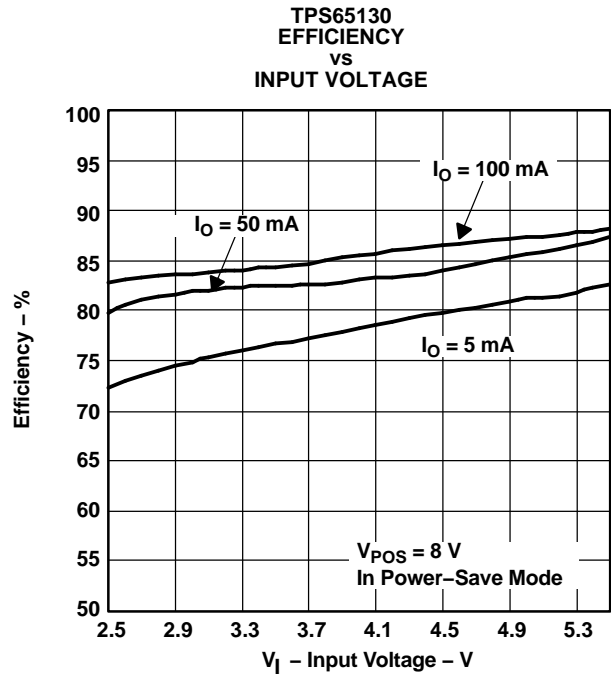

Figure 18.

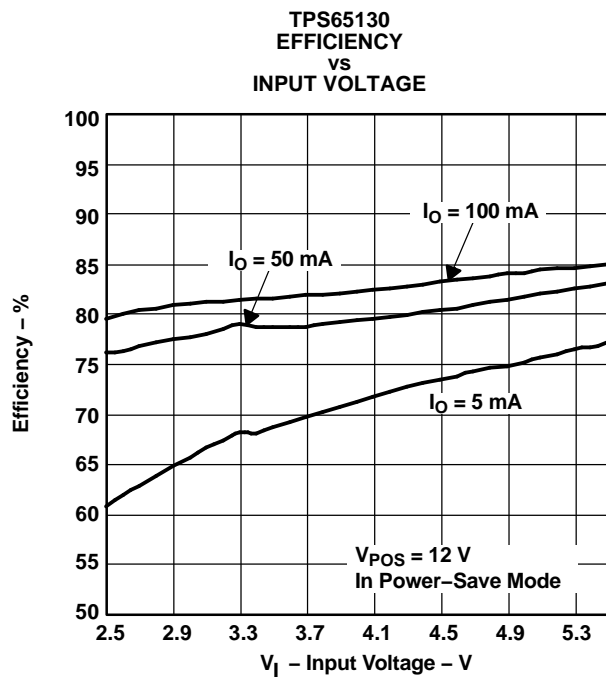

Figure 19.

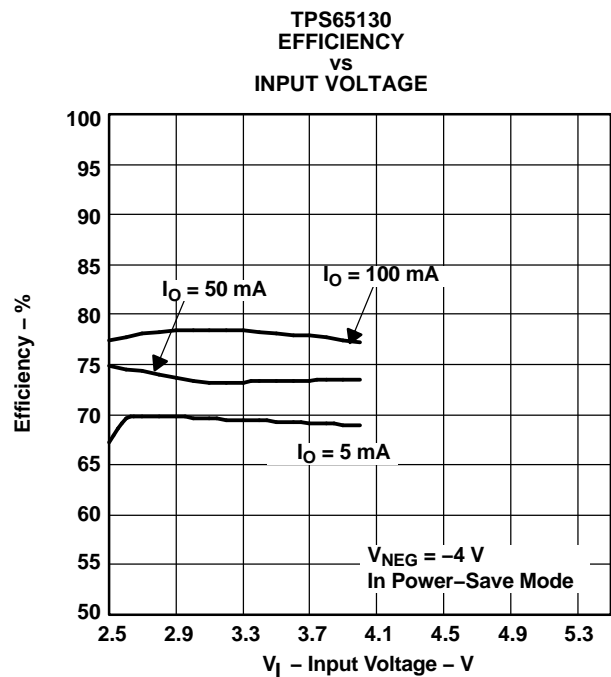

Figure 20.

TYPICAL CHARACTERISTICS (continued)

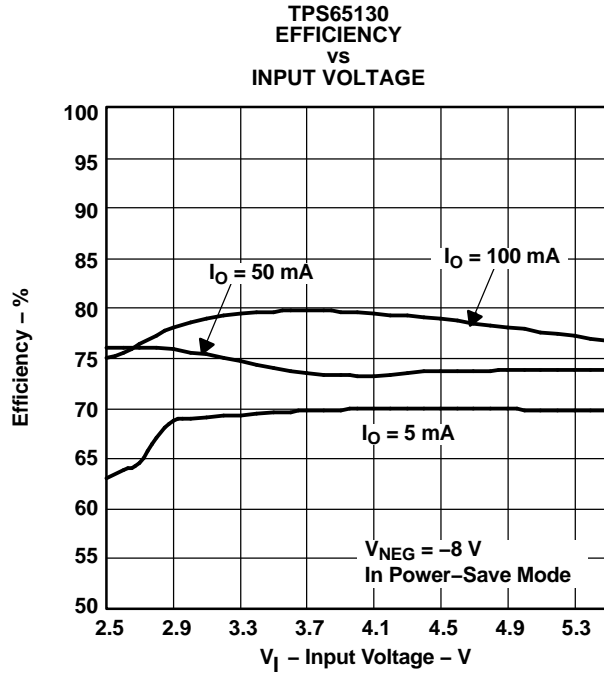

Figure 21.

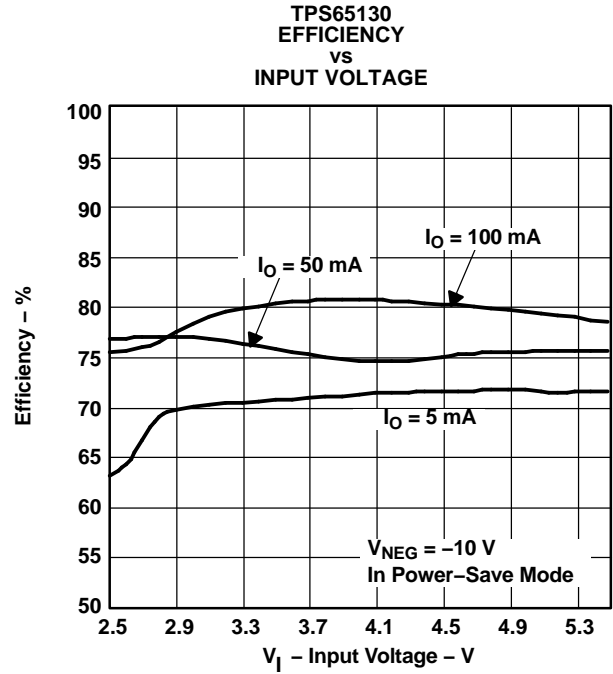

Figure 22.

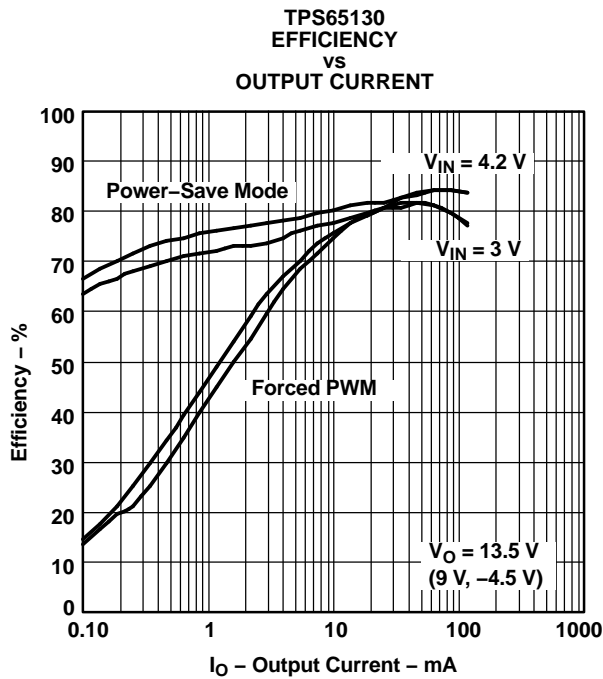

Figure 23.

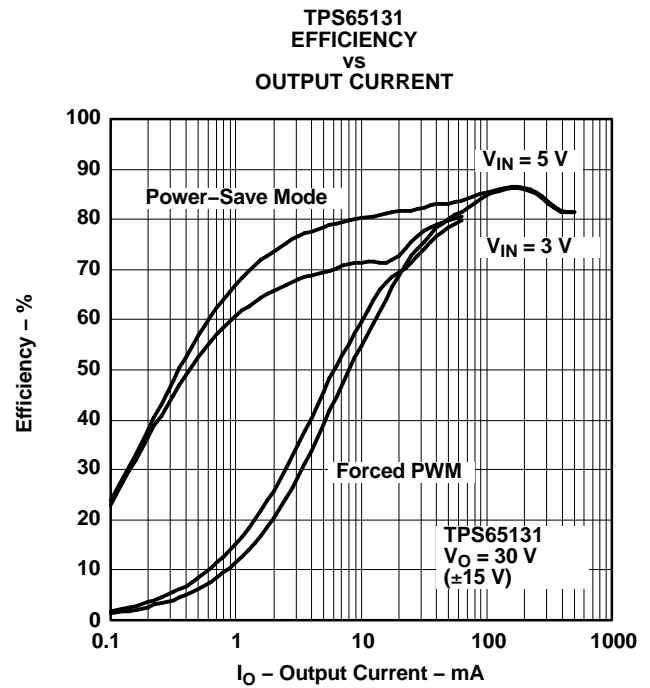

Figure 24.

TYPICAL CHARACTERISTICS (continued)

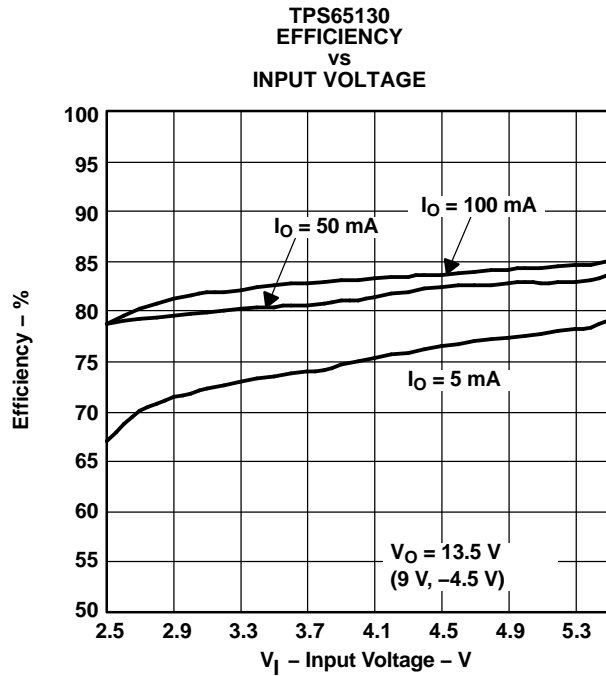

Figure 25.

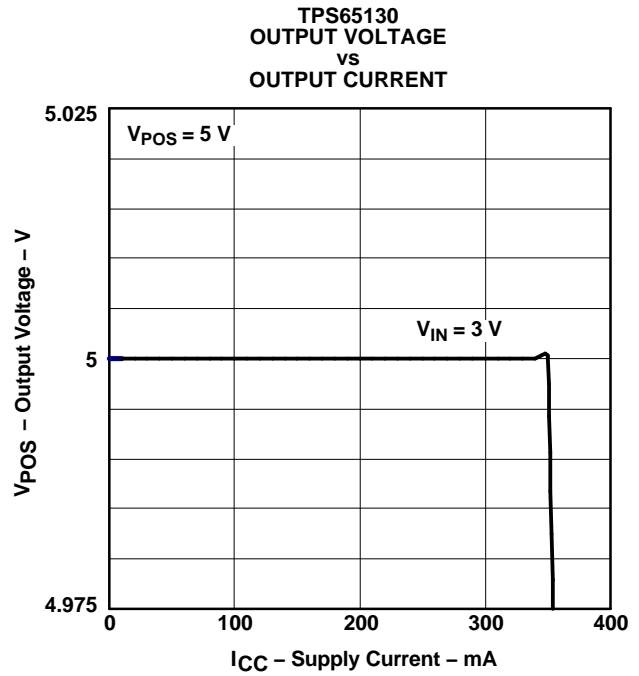

Figure 26.

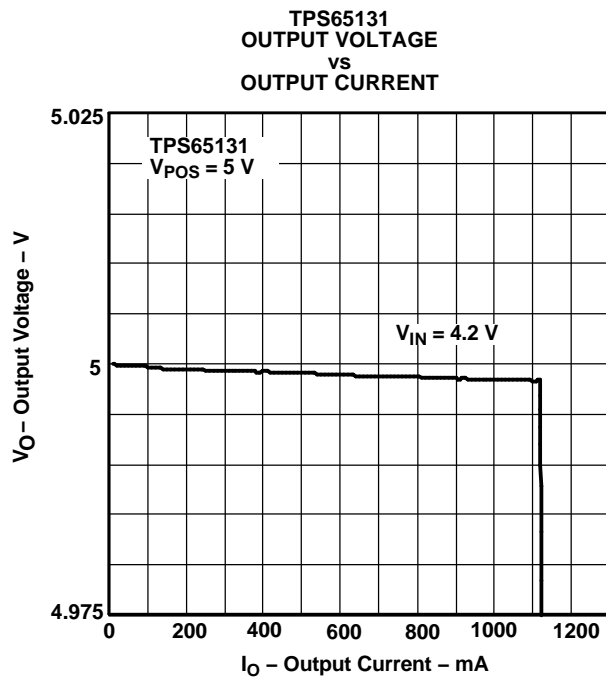

Figure 27.

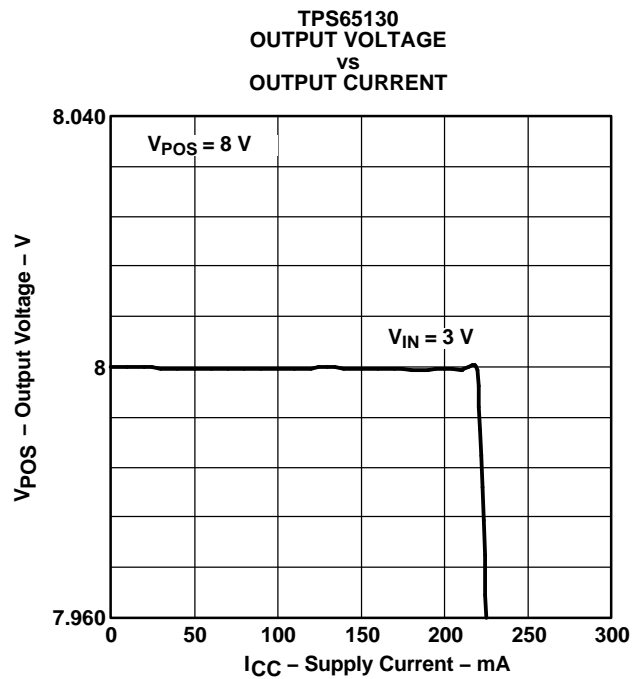
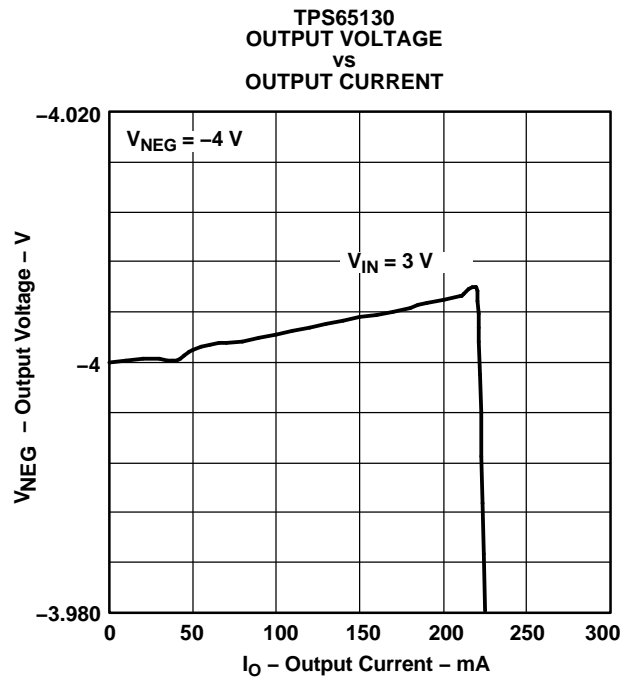
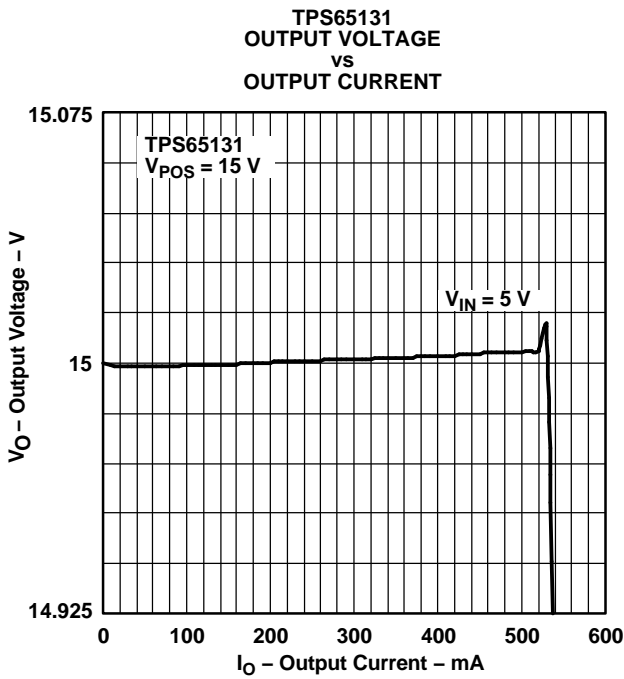
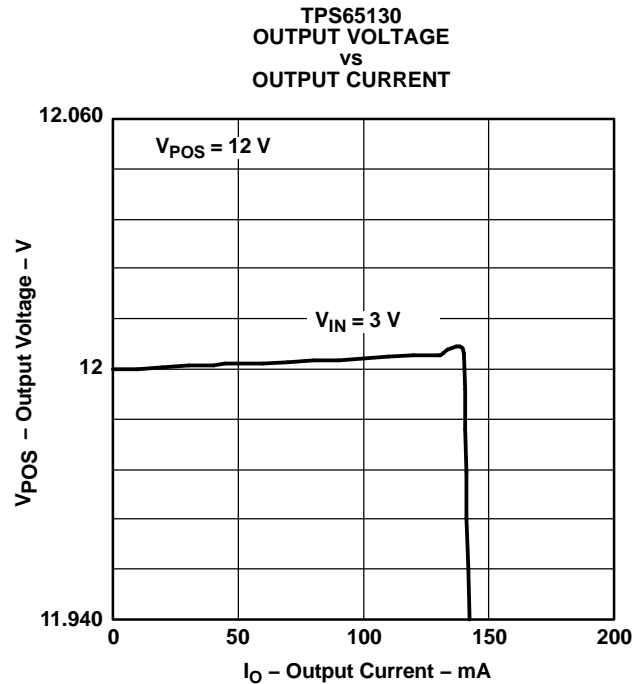
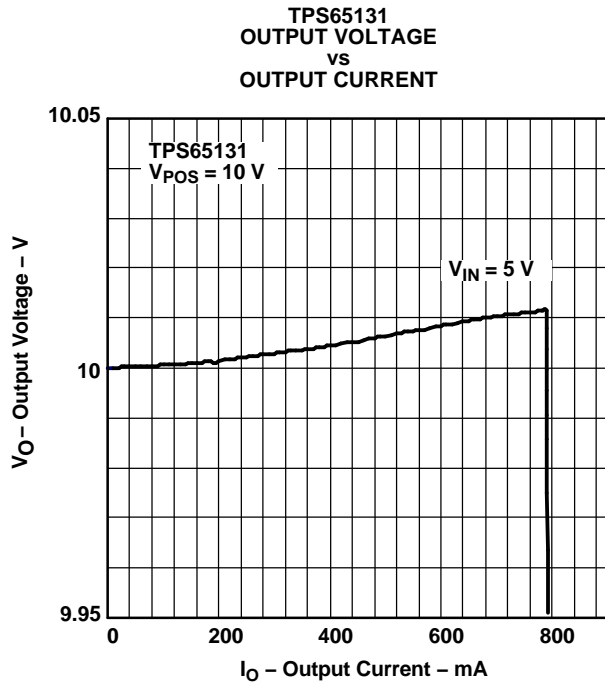
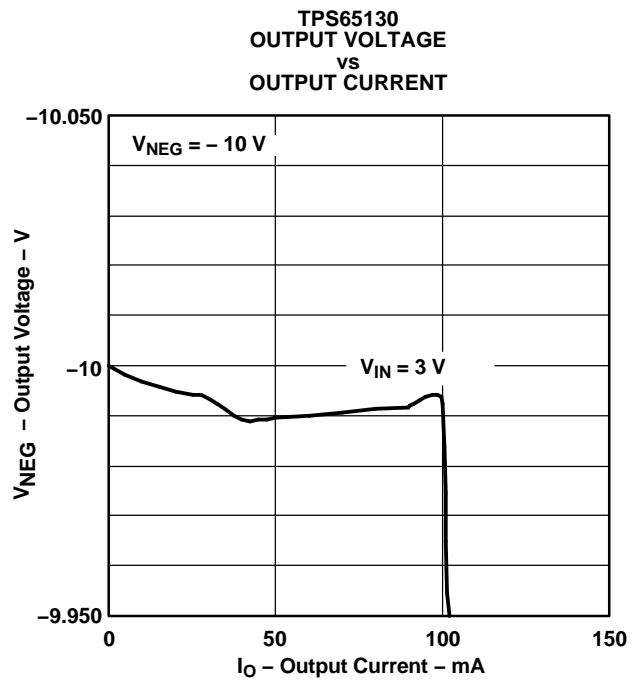
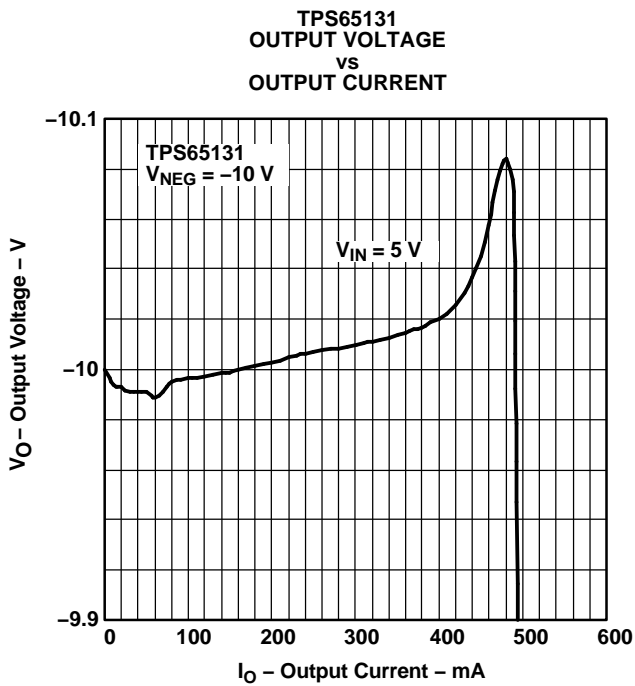
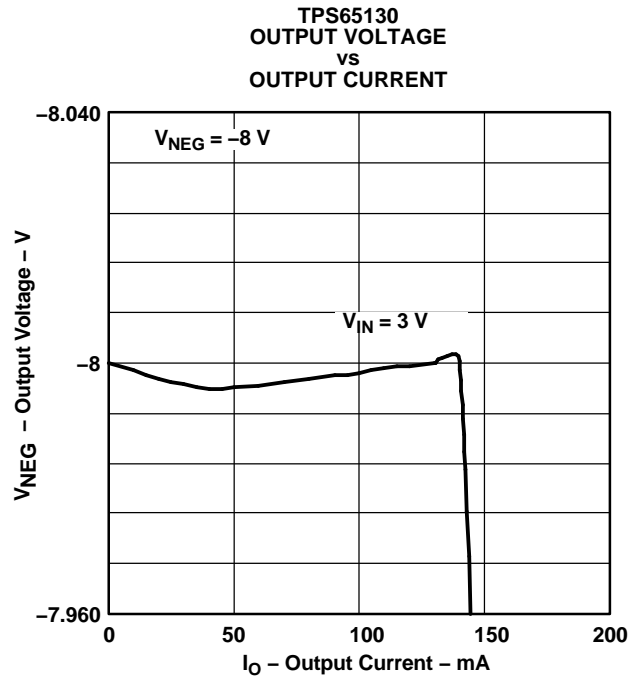
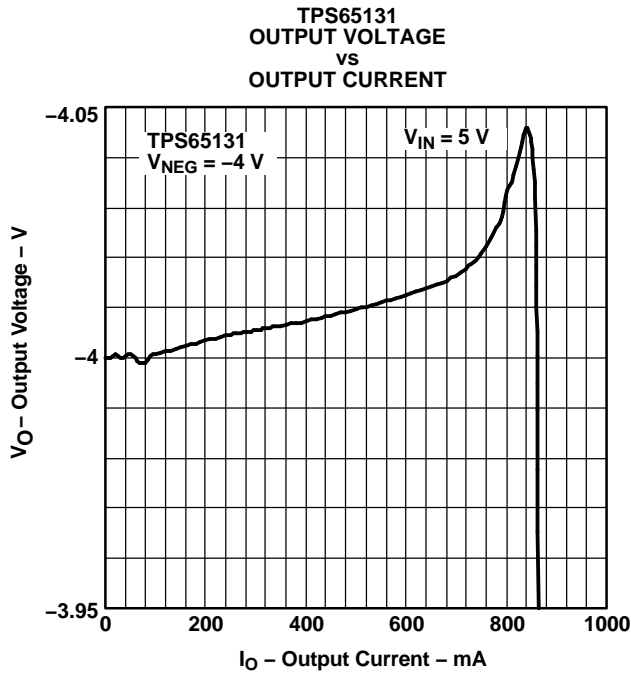

Figure 28.

TYPICAL CHARACTERISTICS (continued)



TYPICAL CHARACTERISTICS (continued)



TYPICAL CHARACTERISTICS (continued)

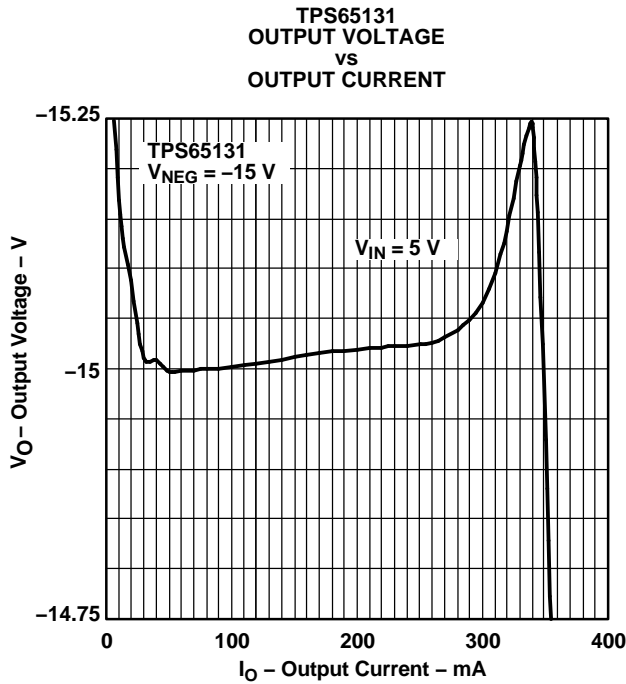

Figure 37.

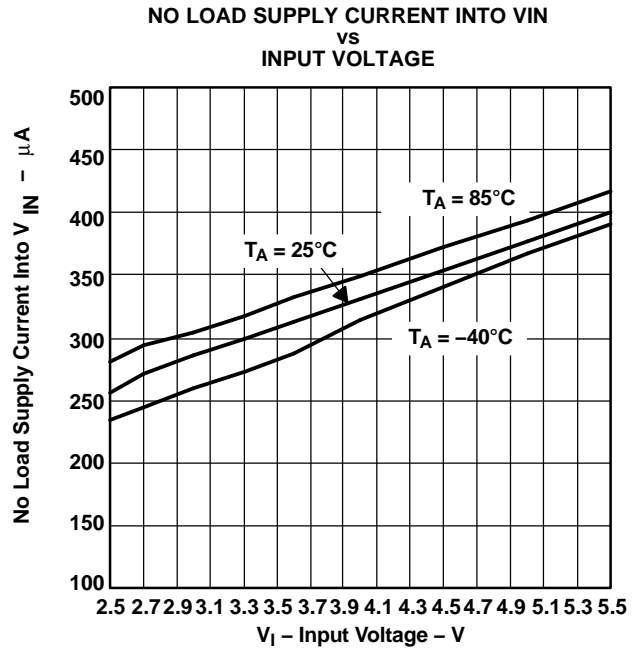

Figure 38.

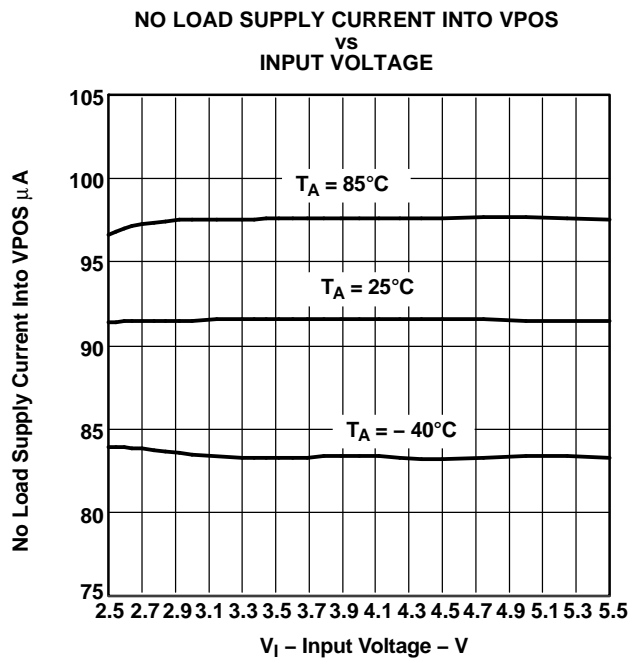

Figure 39.

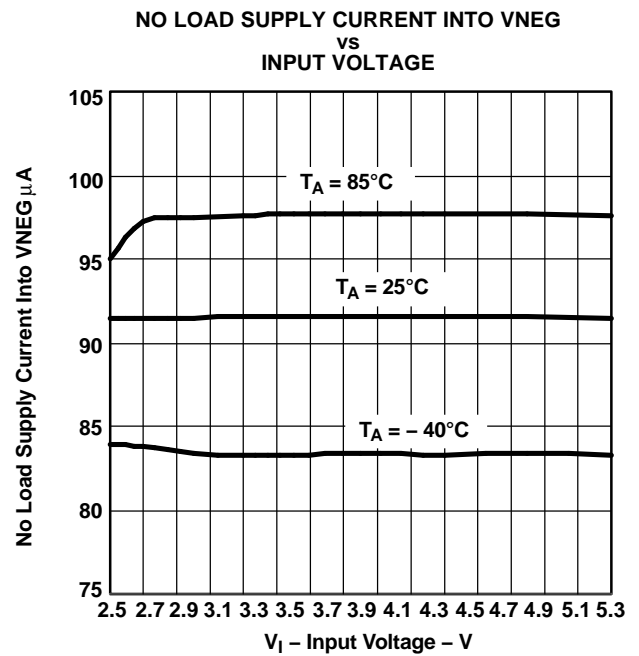

Figure 40.

TYPICAL CHARACTERISTICS (continued)

POSITIVE OUTPUT VOLTAGE
IN CONTINUOUS CURRENT MODE

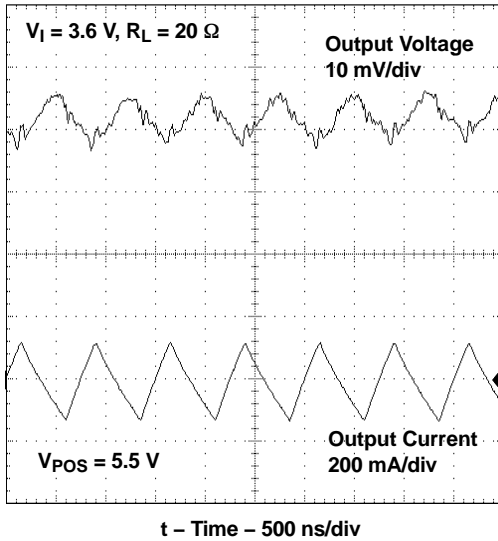

Figure 41.

NEGATIVE OUTPUT VOLTAGE
IN CONTINUOUS CURRENT MODE

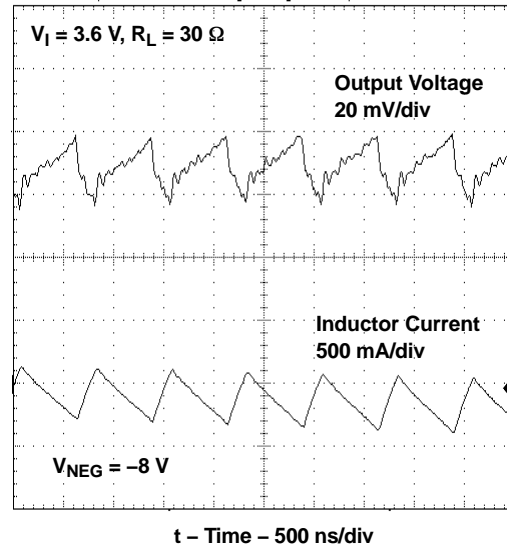

Figure 42.

POSITIVE OUTPUT VOLTAGE
AT POWER-SAVE MODE DISABLED

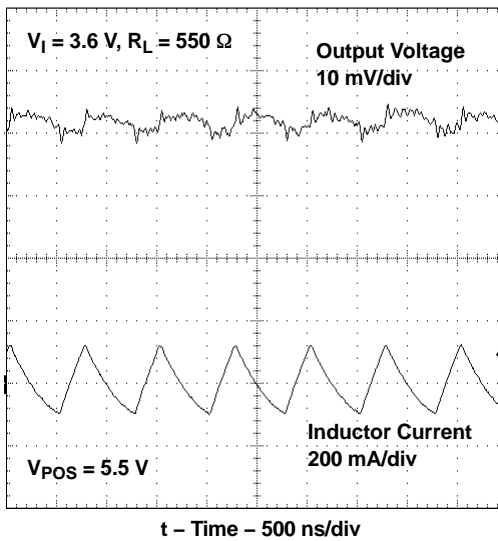

Figure 43.

NEGATIVE OUTPUT VOLTAGE
AT POWER-SAVE MODE DISABLED

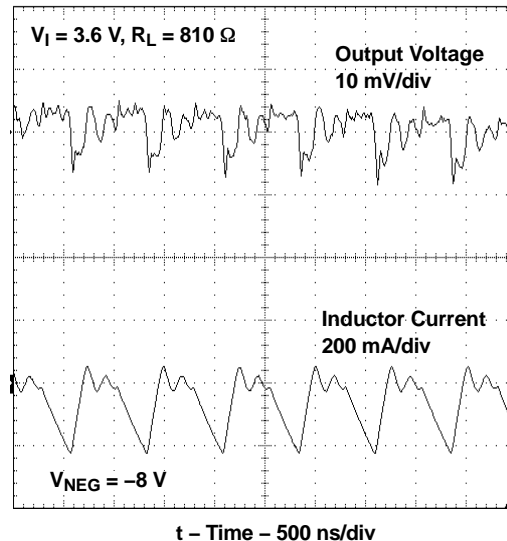
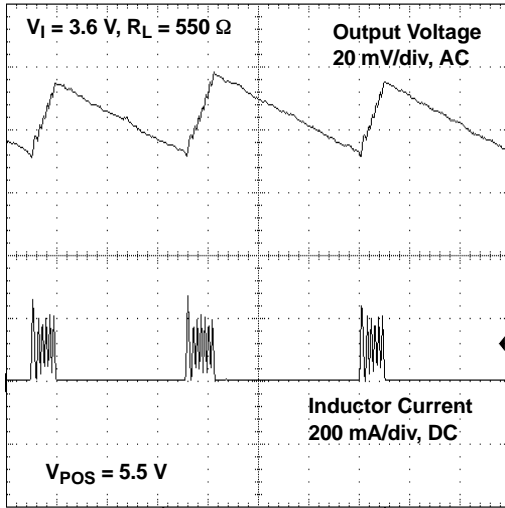

Figure 44.

TYPICAL CHARACTERISTICS (continued)

**POSITIVE OUTPUT VOLTAGE
IN POWER-SAVE MODE**



t – Time – 10 $\mu\text{s}/\text{div}$

Figure 45.

**NEGATIVE OUTPUT VOLTAGE
IN POWER-SAVE MODE**

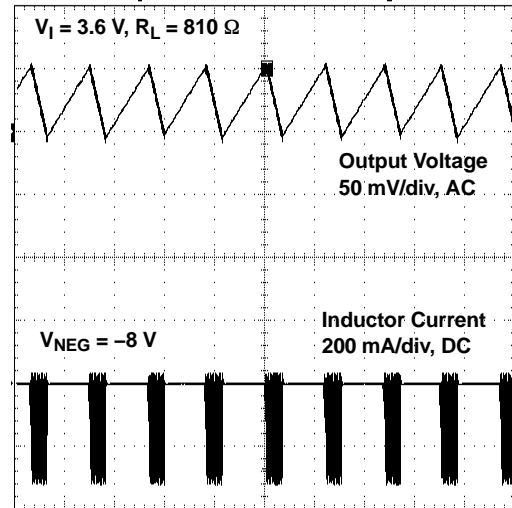

t – Time – 50 $\mu\text{s}/\text{div}$

Figure 46.

LOAD TRANSIENT RESPONSE

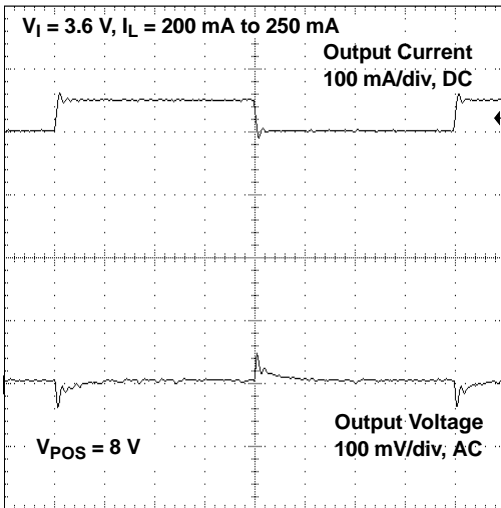

t – Time – 500 $\mu\text{s}/\text{div}$

Figure 47.

LOAD TRANSIENT RESPONSE

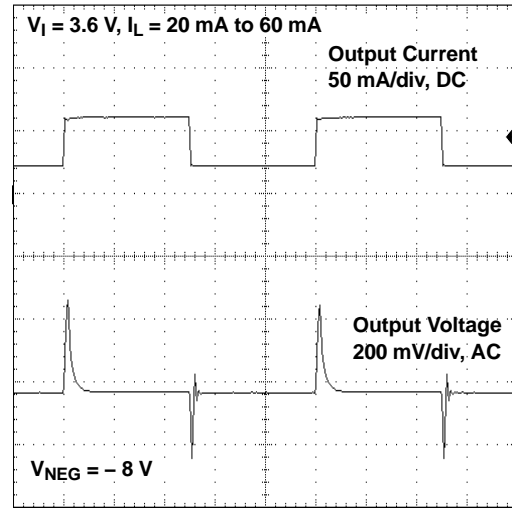

t – Time – 2 ms/div

Figure 48.

TYPICAL CHARACTERISTICS (continued)

LINE TRANSIENT RESPONSE

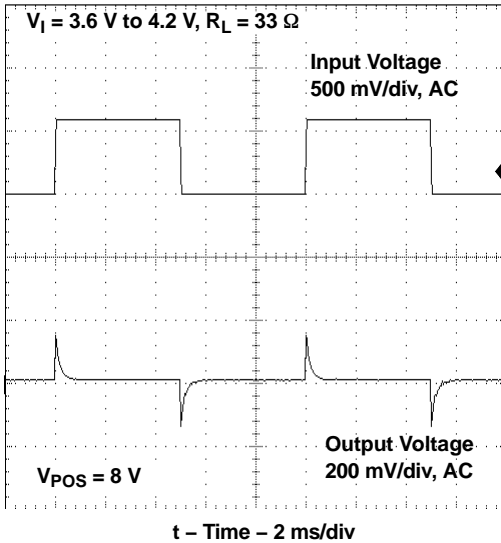

Figure 49.

LINE TRANSIENT RESPONSE

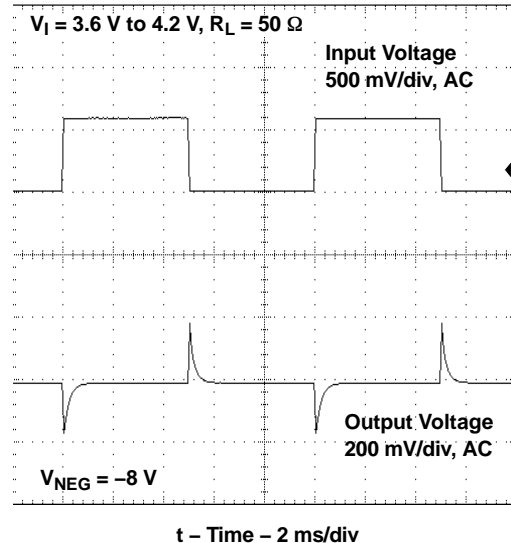

Figure 50.

START-UP AFTER ENABLE

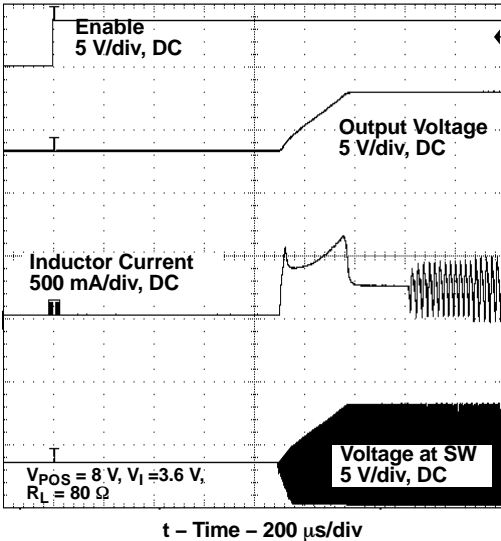

Figure 51.

START-UP AFTER ENABLE

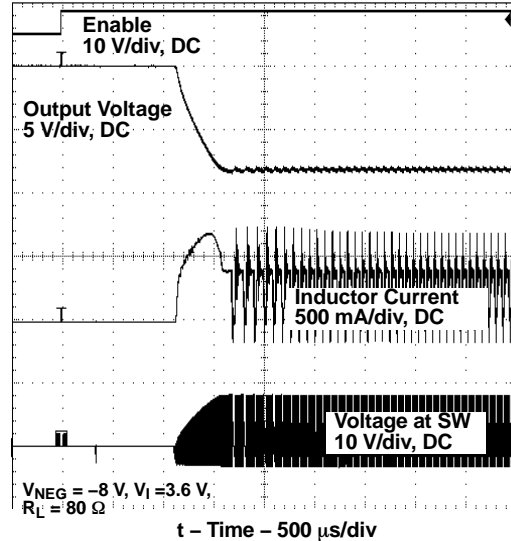

Figure 52.

DETAILED DESCRIPTION

The TPS65130/1 operates with an input voltage range of 2.7 V to 5.5 V and can generate both a positive and negative output. Both converters work independently of each other. They only share a common clock and a common voltage reference. Both outputs are separately controlled by a fixed-frequency, pulse-width-modulated (PWM) regulator. In general, each converter operates at continuous conduction mode (CCM). At light loads, the negative converter can enter discontinuous conduction mode (DCM). As the load current decreases, the converters can enter a power-save mode if enabled. This works independently at both converters. Output voltages can go up to 15 V at the boost output and down to -15 V at the inverter output.

DETAILED DESCRIPTION (continued)**Power Conversion**

Both converters operate in a fixed-frequency, PWM control scheme. So, the on-time of the switches varies depending on input-to-output voltage ratio and the load. During this on-time, the inductors connected to the converters are charged with current. In the remaining time, the time period set by the fixed operating frequency, the inductors discharge into the output capacitors via the rectifier diodes. Usually at higher loads, the inductor currents are continuous. At lighter loads, the boost converter uses an additional internal switch to allow current flowing back to the input. This avoids inductor current becoming discontinuous in the boost converter. So, the boost converter is always controlled in a continuous current mode. At the inverting converter, during light loads, the inductor current can become discontinuous. In this case, the control circuit of the inverting controller output automatically takes care of these changing conditions to always operate with an optimum control setup.

Control

The controller circuits of both converters are based on a fixed-frequency, multiple-feedforward controller topology. Input voltage, output voltage, and voltage drop across the switches are monitored and forwarded to the regulator. Changes in the operating conditions of the converters directly affect the duty cycle and must not take the indirect and slow way through the output voltage control loops. Measurement errors in this feedforward system are corrected by a self-learning control system. To avoid output voltage steps due to output changes of this self-learning control system, its output is dampened by an external capacitor.

The voltage loops, determined by the error amplifiers, only have to handle small signal errors. The error amplifiers are internally compensated. Their inputs are the feedback voltages on the FBP and FBN pins. These voltages are compared with the internal reference voltage to generate an accurate and stable output voltage.

Power-Save Mode

The PSN and PSP can be used to select different operating modes. To enable power-save mode for the corresponding converter, the dedicated PS pin must be set high. Power-save mode can be used to improve efficiency at light load. In power-save mode, the converter only operates when the output voltage falls below a set threshold voltage. It ramps up the output voltage with one or several operating pulses and goes again into power-save mode once the inductor current goes discontinuous. The power-save mode can be disabled separately for each converter by setting the corresponding PS pin low.

Enable

Applying a low signal at the enable ENP or ENN pins shuts down the corresponding converter. When both enable pins are tied low, the device enters shutdown mode, where all internal circuitry is turned off. The device now just consumes low shutdown current flowing into the VIN pin. The output loads of the converters are disconnected from the battery as described in the following paragraph. Pulling the enable pins high enables the corresponding converter. Internal circuitry, necessary to operate the specific converter, is then turned on.

Load Disconnect

The device supports completely disconnecting the load, when the converters are disabled. At the inverting converter, this is done by just turning off the internal PMOS switch. If the inverting converter is turned off, no DC current path remains which could discharge the battery. This is different at the boost converter. The external rectifying diode, together with the boost inductor, form a DC current path which could discharge the battery if any load is connected at the output. The device has no internal switch to prevent current from flowing. For this reason, a PMOS gate control output (BSW) is implemented. A PMOS switch can be placed into this DC current path, ideally, directly between the boost inductor and battery. To be able to really disconnect the battery, the forward direction of the parasitic backgate diode of this switch must point to the battery. The external PMOS switch, connected to BSW, turns on when the boost converter is enabled and is turned off when the boost converter is disabled.

DETAILED DESCRIPTION (continued)

Soft Start

Both converters have implemented soft-start functions. When each converter is enabled, the implemented switch current limit ramps up slowly to its nominal programmed value in about 1 ms. Soft start is implemented to limit the input current during start-up to avoid high peak currents at the battery which could interfere with other systems connected to the same battery. Without soft start, uncontrolled input peak currents flow to charge up the output capacitors and to supply the load during start-up. Their values could increase the implemented switch current limit, which has serious impact to the converter itself and other parts of the system, by causing significant voltage drops across the series resistance of the battery and its connections.

Overvoltage Protection

Both built-in converters have implemented overvoltage protection. If the feedback voltage under normal operation exceeds the nominal value by typically 5%, the corresponding converter shuts down immediately to protect any connected circuitry from possible damage.

Undervoltage Lockout

An undervoltage lockout prevents the device from starting up and operating if the supply voltage at VIN is lower than the programmed threshold shown in the electrical characteristic table. The device automatically shuts down both converters when the supply voltage at VIN falls below this threshold. Nevertheless, parts of the control circuits remain active, which is different than device shutdown using EN inputs. The undervoltage lockout function is implemented to prevent device malfunction.

Overtemperature Shutdown

The device automatically shuts down both converters if the implemented internal temperature detector detects a chip temperature above the programmed threshold shown in the electrical characteristics table. It automatically starts operating again when the chip temperature falls below this threshold. A built-in hysteresis avoids undefined operation caused by ringing from shutdown and prevents operating at a temperature close to the overtemperature shutdown threshold.

APPLICATION INFORMATION

Design Procedure

The TPS65130/1 dc-dc converter is intended for systems typically powered by a single-cell Li-ion or Li-polymer battery with a terminal voltage between 2.7 V up to 4.2 V. Because the recommended input voltage goes up to 5.5 V, the device is also suitable for 3-cell alkaline, NiCd, or NiMH batteries, as well as any regulated supply voltages between 2.7 V and 5.5 V. It provides two independent output voltage rails which are programmed as follows.

Programming the Output Voltage

Boost Converter

The output voltage of the TPS65130/1 boost converter stage can be adjusted with an external resistor divider connected to the FBP pin. The typical value of the voltage at the FBP pin is the reference voltage, which is 1.213 V. The maximum recommended output voltage at the boost converter is 15 V. To achieve appropriate accuracy, the current through the feedback divider should be about 100 times higher than the current into the FBP pin. Typical current into the FBP pin is 0.05 μ A, and the voltage across R_2 is 1.213 V. Based on those values, the recommended value for R_2 should be lower than 200 k Ω in order to set the divider current at 5 μ A or higher. Depending on the needed output voltage (V_{POS}), the value of the resistor R_1 can then be calculated using Equation 1:

$$R_1 = R_2 \times \left(\frac{V_{POS}}{V_{REF}} - 1 \right) \quad (1)$$

As an example, if an 8-V output is needed, and a resistor of 180 k Ω has been chosen for R_2 , a 1-M Ω resistor is needed to program the desired output voltage.

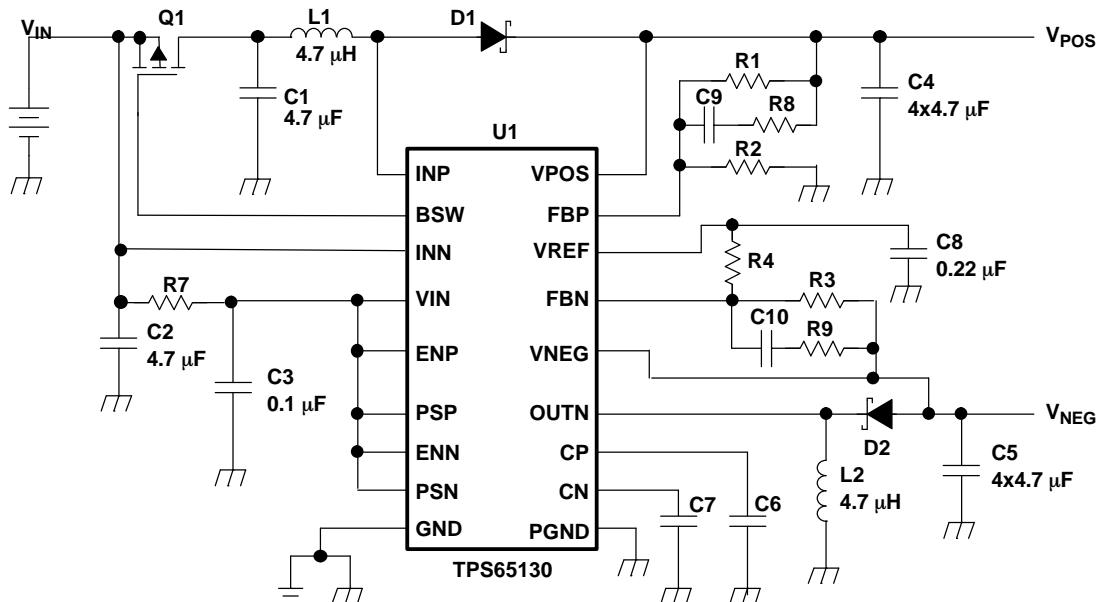

Inverting Converter

The output voltage of the TPS65130/1 inverting converter stage can also be adjusted with an external resistor divider. It must be connected to the FBN pin. In difference to the feedback divider at the boost converter, the reference point of the feedback divider is not GND; it is V_{REF} . So the typical value of the voltage at the FBN pin is 0 V. The minimum recommended output voltage at the inverting converter is –15 V. Feedback divider current

APPLICATION INFORMATION (continued)

considerations are similar to the considerations at the boost converter. For the same reasons, the feedback divider current should be in the range of 5 μ A or higher. The voltage across R_4 is 1.213 V. Based on those values, the recommended value for R_4 should be lower than 200 k Ω in order to set the divider current at the required value. The value of the resistor R_3 , depending on the needed output voltage (V_{NEG}), can be calculated using Equation 2:

$$R_3 = R_4 \times \left(\frac{V_{REF} - V_{NEG}}{V_{REF}} - 1 \right) \tag{2}$$

If as an example an output voltage of -5 V is needed and a resistor of 180 k Ω has been chosen for R_4 , a 750-k Ω resistor is needed to program the desired output voltage.

Inductor Selection

An inductive converter normally requires two main passive components for storing energy during the conversion. An inductor and a storage capacitor at the output are required. In selecting the right inductor, it is recommended to keep the possible peak inductor current below the current-limit threshold of the power switch in the chosen configuration. For example, the current-limit threshold of the switch for the boost converter and for the inverting converter, is nominally 800 mA at TPS65130 and 1950 mA at TPS65131. The highest peak current through the switches and the inductor depend on the output load, the input voltage (V_{IN}), and the output voltages (V_{POS} , V_{NEG}). Estimation of the peak inductor current in the boost converter can be done using Equation 3. Equation 4 shows the corresponding formula for the inverting converter.

$$I_{LP} = \frac{V_{POS}}{V_{IN} \times 0.64} \times I_{OUTP} \tag{3}$$

$$I_{LN} = \frac{V_{IN} - V_{NEG}}{V_{IN} \times 0.64} \times I_{OUTN} \tag{4}$$

The second parameter for choosing the inductor is the desired current ripple in the inductor. Normally, it is advisable to work with a ripple of less than 20% of the average inductor current. A smaller ripple reduces the losses in the inductor, as well as output voltage ripple and EMI. But in the same way, output voltage regulation gets slower, causing higher voltage changes at fast load changes. In addition, a larger inductor usually increases the total system cost. Keeping those parameters in mind, the possible inductor value can be calculated using Equation 5 for the boost converter and Equation 6 for the inverting converter.

$$L_P = \frac{V_{IN} \times (V_{POS} - V_{IN})}{\Delta I_{LP} \times f_S \times V_{POS}} \tag{5}$$

$$L_N = \frac{V_{IN} \times V_{NEG}}{\Delta I_{LN} \times f_S \times (V_{NEG} - V_{IN})} \tag{6}$$

Parameter f is the switching frequency and ΔI_L is the ripple current in the inductor, i.e., 20% $\times I_L$. V_{IN} is the input voltage, which is assumed to be at 3.3 V in this example. So, the calculated inductance value for the boost inductor is 5.1 μ H and for the inverting converter inductor is 5.1 μ H. With these calculated values and the calculated currents, it is possible to choose a suitable inductor. In typical applications, a 4.7- μ H inductor is recommended. The device has been optimized to work with inductance values between 3.3 μ H and 6.8 μ H. Nevertheless, operation with higher inductance values may be possible in some applications. Detailed stability analysis is then recommended. Care has to be taken for the possibility that load transients and losses in the circuit can lead to higher currents as estimated in Equation 3 and Equation 4. Also, the losses caused by magnetic hysteresis losses and copper losses are a major parameter for total circuit efficiency.

APPLICATION INFORMATION (continued)

The following inductor series from different suppliers have been used with the TPS65130/1 converter:

List of Inductors

VENDOR	INDUCTOR SERIES
EPCOS	B8246284-G4
Würth Elektronik	7447789XXX
	744031XXX
TDK	VL3010
	VL4012
Cooper Electronics Technologies	SD12

Capacitor Selection

Input Capacitor

At least a 4.7- μ F input capacitor is recommended for the input of the boost converter (INP) and for the input of the inverting converter (INN) to improve transient behavior of the regulators and EMI behavior of the total power supply circuit. A ceramic capacitor or a tantalum capacitor with a smaller ceramic capacitor (100 nF) in parallel, placed close to the input pins, is recommended.

Output Capacitors

One of the major parameters necessary to define the capacitance value of the output capacitor is the maximum allowed output voltage ripple of the converter. This ripple is determined by two parameters of the capacitor, the capacitance and the ESR. It is possible to calculate the minimum capacitance needed for the defined ripple, supposing that the ESR is zero, by using Equation 7 for the boost converter output capacitor and Equation 8 for the inverting converter output capacitor.

$$C_{\min P} = \frac{I_{\text{OUTP}} \times (V_{\text{POS}} - V_{\text{IN}})}{f_S \times \Delta V_P \times V_{\text{POS}}} \quad (7)$$

$$C_{\min N} = \frac{I_{\text{OUTN}} \times V_{\text{NEG}}}{f_S \times \Delta V_N \times (V_{\text{NEG}} - V_{\text{IN}})} \quad (8)$$

Parameter f is the switching frequency and ΔV is the maximum allowed ripple.

With a chosen ripple voltage in the range of 10 mV, a minimum capacitance of 12 μ F is needed. The total ripple is larger due to the ESR of the output capacitor. This additional component of the ripple can be calculated using Equation 9 for the boost converter and Equation 10 for the inverting converter.

$$\Delta V_{\text{ESRP}} = I_{\text{OUTP}} \times R_{\text{ESRP}} \quad (9)$$

$$\Delta V_{\text{ESRN}} = I_{\text{OUTN}} \times R_{\text{ESRN}} \quad (10)$$

An additional ripple of 2 mV is the result of using a typical ceramic capacitor with an ESR in a 10-m Ω range. The total ripple is the sum of the ripple caused by the capacitance and the ripple caused by the ESR of the capacitor. In this example, the total ripple is 10 mV. Additional ripple is caused by load transients. When the load current increases rapidly, the output capacitor must provide the additional current until the inductor current has been increased by the control loop by setting a higher on-time at the main switch (duty cycle). The higher duty cycle results in longer inductor charging periods. But the rate of increase of the inductor current is also limited by the inductance itself. When the load current decreases rapidly, the output capacitor needs to store the excessive energy (stored in the inductor) until the regulator has decreased the inductor current by reducing the duty cycle. The recommendation is to use higher capacitance values, as the foregoing calculations show.

Stabilizing the Control Loop

Feedback Divider

To speed up the control loop, feedforward capacitors are recommended in the feedback divider, parallel to R1 (boost converter) and R3 (inverting converter). Equation 11 shows how to calculate the appropriate value for the boost converter, and Equation 12 for the inverting converter.

$$C9 = \frac{6.8 \mu\text{s}}{R1} \quad (11)$$

$$C10 = \frac{7.5 \mu\text{s}}{R3} \quad (12)$$

To avoid coupling noise into the control loop from the feedforward capacitors, the feedforward effect can be bandwidth-limited by adding a series resistor. Any value between 10 k Ω and 100 k Ω is suitable. The higher the resistance, the lower the noise coupled into the control loop system.

Compensation Capacitors

The control loops of both converters are completely compensated internally. The complex internal input voltage output voltage, and input-current feedforward system has built-in error correction which requires external capacitors. A 10-nF capacitor at CP of the boost converter and a 4.7-nF capacitor at CN of the inverting converter is recommended.

Layout Considerations

As for all switching power supplies, the layout is an important step in the design, especially at high peak currents and high switching frequencies. If the layout is not carefully done, the regulator could show stability problems as well as EMI problems. Therefore, use wide and short traces for the main current paths and for the power ground tracks. The input capacitors, output capacitors, the inductors, and the rectifying diodes should be placed as close as possible to the IC to keep parasitic inductances low. Use a common ground node for power ground and a different node for control grounds to minimize the effects of ground noise. Connect these ground nodes at any place close to one of the ground pins of the IC.

The feedback dividers should be placed as close as possible to the control ground pin (boost converter) or the VREF pin (inverting converter) of the IC. To lay out the control ground, it is recommended to use short traces as well, separated from the power ground traces. This avoids ground shift problems, which can occur due to superimposition of power ground current and control ground current.

THERMAL INFORMATION

Implementation of integrated circuits in low-profile and fine-pitch surface-mount packages typically requires special attention to power dissipation. Many system-dependent issues, such as thermal coupling, airflow, added heatsinks and convection surfaces, and the presence of heat-generating components affect the power-dissipation limits of a given component.

Three basic approaches for enhancing thermal performance follow.

- Improving the power dissipation capability of the PCB design
- Improving the thermal coupling of the component to the PCB
- Introducing airflow to the system

The maximum recommended junction temperature (T_J) of the TPS65130/1 devices is 125°C. The thermal resistance of the 24-pin QFN, 4x4-mm package (RGE) is $R_{\theta JA} = 37.8^\circ\text{C/W}$. Specified regulator operation is ensured to a maximum ambient temperature T_A of 85°C. Therefore, the maximum power dissipation is about 1058 mW. More power can be dissipated if the maximum ambient temperature of the application is lower.

$$P_{D\text{MAX}} = \frac{T_{J\text{MAX}} - T_A}{R_{\theta JA}} \quad (13)$$

PACKAGING INFORMATION

Orderable Device	Status ⁽¹⁾	Package Type	Package Drawing	Pins	Package Qty	Eco Plan ⁽²⁾	Lead/Ball Finish	MSL Peak Temp ⁽³⁾
TPS65130RGER	ACTIVE	QFN	RGE	24	3000	Green (RoHS & no Sb/Br)	CU NIPDAU	Level-2-260C-1 YEAR
TPS65130RGERG4	ACTIVE	QFN	RGE	24	3000	Green (RoHS & no Sb/Br)	CU NIPDAU	Level-2-260C-1 YEAR
TPS65130RGET	ACTIVE	QFN	RGE	24	250	Green (RoHS & no Sb/Br)	CU NIPDAU	Level-2-260C-1 YEAR
TPS65130RGETG4	ACTIVE	QFN	RGE	24	250	Green (RoHS & no Sb/Br)	CU NIPDAU	Level-2-260C-1 YEAR
TPS65131RGER	ACTIVE	QFN	RGE	24	3000	Green (RoHS & no Sb/Br)	CU NIPDAU	Level-2-260C-1 YEAR
TPS65131RGERG4	ACTIVE	QFN	RGE	24	3000	Green (RoHS & no Sb/Br)	CU NIPDAU	Level-2-260C-1 YEAR
TPS65131RGET	ACTIVE	QFN	RGE	24	250	Green (RoHS & no Sb/Br)	CU NIPDAU	Level-2-260C-1 YEAR
TPS65131RGETG4	ACTIVE	QFN	RGE	24	250	Green (RoHS & no Sb/Br)	CU NIPDAU	Level-2-260C-1 YEAR

⁽¹⁾ The marketing status values are defined as follows:

ACTIVE: Product device recommended for new designs.

LIFEBUY: TI has announced that the device will be discontinued, and a lifetime-buy period is in effect.

NRND: Not recommended for new designs. Device is in production to support existing customers, but TI does not recommend using this part in a new design.

PREVIEW: Device has been announced but is not in production. Samples may or may not be available.

OBSOLETE: TI has discontinued the production of the device.

⁽²⁾ Eco Plan - The planned eco-friendly classification: Pb-Free (RoHS), Pb-Free (RoHS Exempt), or Green (RoHS & no Sb/Br) - please check <http://www.ti.com/productcontent> for the latest availability information and additional product content details.

TBD: The Pb-Free/Green conversion plan has not been defined.

Pb-Free (RoHS): TI's terms "Lead-Free" or "Pb-Free" mean semiconductor products that are compatible with the current RoHS requirements for all 6 substances, including the requirement that lead not exceed 0.1% by weight in homogeneous materials. Where designed to be soldered at high temperatures, TI Pb-Free products are suitable for use in specified lead-free processes.

Pb-Free (RoHS Exempt): This component has a RoHS exemption for either 1) lead-based flip-chip solder bumps used between the die and package, or 2) lead-based die adhesive used between the die and leadframe. The component is otherwise considered Pb-Free (RoHS compatible) as defined above.

Green (RoHS & no Sb/Br): TI defines "Green" to mean Pb-Free (RoHS compatible), and free of Bromine (Br) and Antimony (Sb) based flame retardants (Br or Sb do not exceed 0.1% by weight in homogeneous material)

⁽³⁾ MSL, Peak Temp. -- The Moisture Sensitivity Level rating according to the JEDEC industry standard classifications, and peak solder temperature.

Important Information and Disclaimer:The information provided on this page represents TI's knowledge and belief as of the date that it is provided. TI bases its knowledge and belief on information provided by third parties, and makes no representation or warranty as to the accuracy of such information. Efforts are underway to better integrate information from third parties. TI has taken and continues to take reasonable steps to provide representative and accurate information but may not have conducted destructive testing or chemical analysis on incoming materials and chemicals. TI and TI suppliers consider certain information to be proprietary, and thus CAS numbers and other limited information may not be available for release.

In no event shall TI's liability arising out of such information exceed the total purchase price of the TI part(s) at issue in this document sold by TI to Customer on an annual basis.

MECHANICAL DATA

RGE (S-PQFP-N24)

PLASTIC QUAD FLATPACK

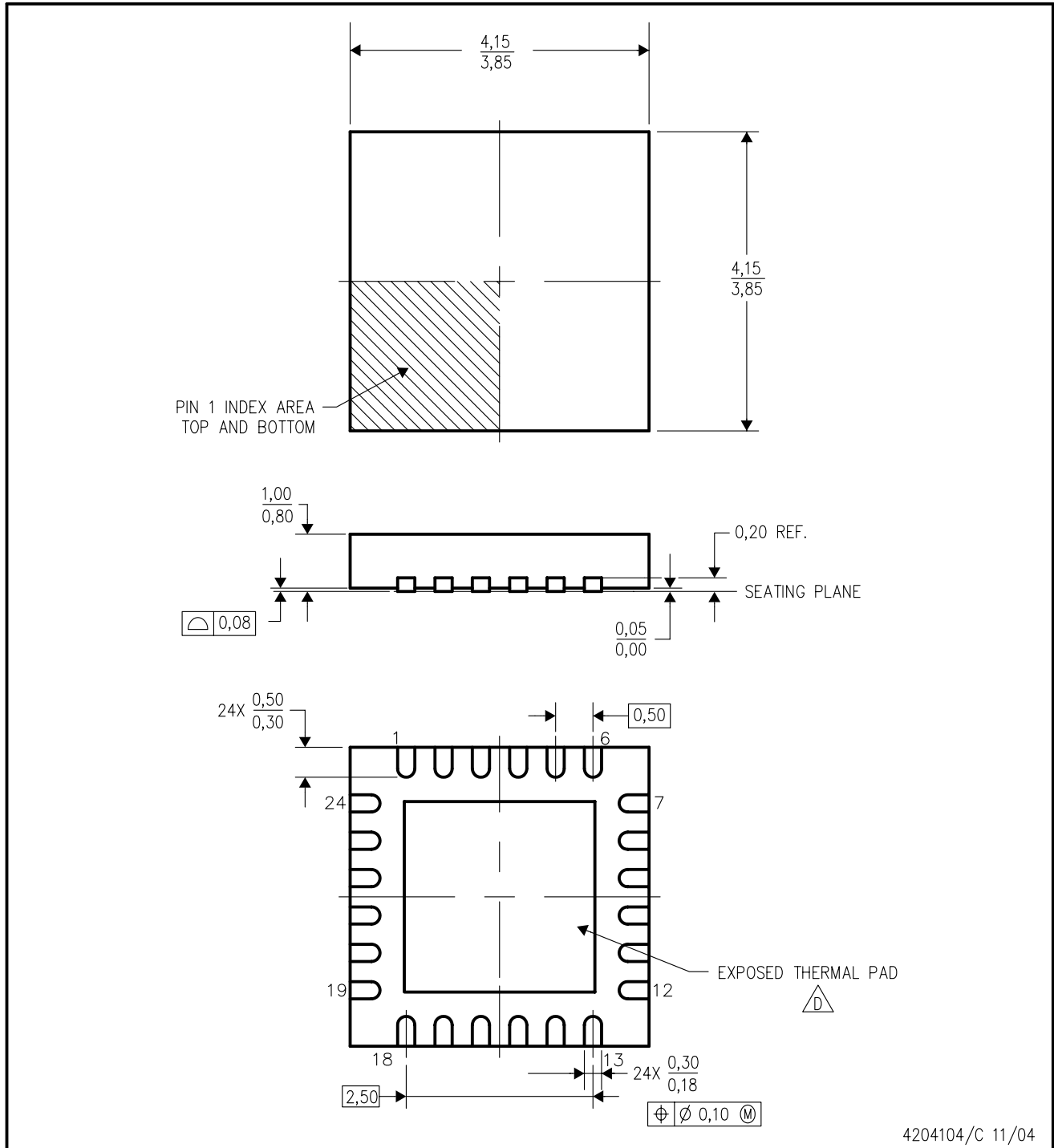

- NOTES:
- A. All linear dimensions are in millimeters. Dimensioning and tolerancing per ASME Y14.5M-1994.
 - B. This drawing is subject to change without notice.
 - C. Quad Flatpack, No-Leads (QFN) package configuration.
 - △ The package thermal pad must be soldered to the board for thermal and mechanical performance. See the Product Data Sheet for details regarding the exposed thermal pad dimensions.
 - E. Falls within JEDEC MO-220.

THERMAL INFORMATION

This package incorporates an exposed thermal pad that is designed to be attached directly to an external heatsink. The thermal pad must be soldered directly to the printed circuit board (PCB), the PCB can be used as a heatsink. In addition, through the use of thermal vias, the thermal pad can be attached directly to a ground plane or special heatsink structure designed into the PCB. This design optimizes the heat transfer from the integrated circuit (IC).

For information on the Quad Flatpack No-Lead (QFN) package and its advantages, refer to Application Report, Quad Flatpack No-Lead Logic Packages, Texas Instruments Literature No. SCBA017. This document is available at www.ti.com.

The exposed thermal pad dimensions for this package are shown in the following illustration.

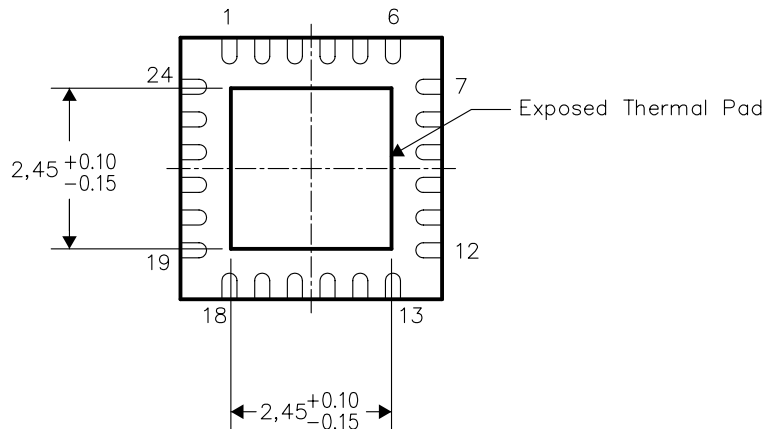

Bottom View

NOTE: All linear dimensions are in millimeters

Exposed Thermal Pad Dimensions

IMPORTANT NOTICE

Texas Instruments Incorporated and its subsidiaries (TI) reserve the right to make corrections, modifications, enhancements, improvements, and other changes to its products and services at any time and to discontinue any product or service without notice. Customers should obtain the latest relevant information before placing orders and should verify that such information is current and complete. All products are sold subject to TI's terms and conditions of sale supplied at the time of order acknowledgment.

TI warrants performance of its hardware products to the specifications applicable at the time of sale in accordance with TI's standard warranty. Testing and other quality control techniques are used to the extent TI deems necessary to support this warranty. Except where mandated by government requirements, testing of all parameters of each product is not necessarily performed.

TI assumes no liability for applications assistance or customer product design. Customers are responsible for their products and applications using TI components. To minimize the risks associated with customer products and applications, customers should provide adequate design and operating safeguards.

TI does not warrant or represent that any license, either express or implied, is granted under any TI patent right, copyright, mask work right, or other TI intellectual property right relating to any combination, machine, or process in which TI products or services are used. Information published by TI regarding third-party products or services does not constitute a license from TI to use such products or services or a warranty or endorsement thereof. Use of such information may require a license from a third party under the patents or other intellectual property of the third party, or a license from TI under the patents or other intellectual property of TI.

Reproduction of information in TI data books or data sheets is permissible only if reproduction is without alteration and is accompanied by all associated warranties, conditions, limitations, and notices. Reproduction of this information with alteration is an unfair and deceptive business practice. TI is not responsible or liable for such altered documentation.

Resale of TI products or services with statements different from or beyond the parameters stated by TI for that product or service voids all express and any implied warranties for the associated TI product or service and is an unfair and deceptive business practice. TI is not responsible or liable for any such statements.

Following are URLs where you can obtain information on other Texas Instruments products and application solutions:

Products		Applications	
Amplifiers	amplifier.ti.com	Audio	www.ti.com/audio
Data Converters	dataconverter.ti.com	Automotive	www.ti.com/automotive
DSP	dsp.ti.com	Broadband	www.ti.com/broadband
Interface	interface.ti.com	Digital Control	www.ti.com/digitalcontrol
Logic	logic.ti.com	Military	www.ti.com/military
Power Mgmt	power.ti.com	Optical Networking	www.ti.com/opticalnetwork
Microcontrollers	microcontroller.ti.com	Security	www.ti.com/security
		Telephony	www.ti.com/telephony
		Video & Imaging	www.ti.com/video
		Wireless	www.ti.com/wireless

Mailing Address: Texas Instruments
Post Office Box 655303 Dallas, Texas 75265