

## PC CARD POWER-INTERFACE SWITCH FOR PCMCIA CONTROLLERS

### FEATURES

- Fully Integrated  $V_{CC}$  and  $V_{PP}/V_{CORE}$  Switching
- Meets PC Card Standards
- $V_{PP}/V_{CORE}$  Output Programmed Independent of  $V_{CC}$
- TTL-Logic Compatible Inputs
- Short Circuit and Thermal Protection
- 20-Pin HTSSOP or 30-Pin SSOP (Dual With Serial Interface) Package
- 14-pin HTSSOP Package (Single With Parallel Interface)
- 95  $\mu$ A Typ Quiescent Current on 3.3 VIN Input (Dual With Serial Interface)
- 64  $\mu$ A Typ Quiescent Current on 3.3 VIN Input (Single With Parallel Interface)
- Break-Before-Make Switching
- Power On Reset
- $-40^{\circ}\text{C}$  to  $85^{\circ}\text{C}$  Ambient Operating Temperature Range

### APPLICATIONS

- Notebook/Desktop Computers
- Personal Digital Assistants (PDAs)
- Digital Cameras
- Bar-code Scanners

### DESCRIPTION

The TPS2228 and TPS2221 PC card power interface switches provide an integrated power management solution for both dual and single PC card sockets. The TPS2228 is a dual-slot power interface switch for serial PCMCIA controllers. The TPS2221 is a single-slot power interface switch for parallel PCMCIA controllers. These power interface switches support the distribution of 3.3 V, 5 V and 1.8 V to the PC card slot while providing current-limiting protection with overcurrent reporting.

### ORDERING INFORMATION(1)

$T_A$	PACKAGED DEVICES	
	DUAL HTSSOP, SSOP	SINGLE HTSSOP
$-40^{\circ}\text{C}$ to $85^{\circ}\text{C}$	TPS2228PWP (20)	TPS2221PWP (14)
	TPS2228DB (30)	

(1) Both DB and PWP packages are available taped and reeled (indicated by the R suffix on the device type; e.g., TPS2228PWPR).

## ABSOLUTE MAXIMUM RATINGS

over operating free-air temperature range unless otherwise noted<sup>(1)</sup>

		TPS2228, TPS2221
Input voltage range for card power	V <sub>I</sub> (3.3VIN)	-0.3 V to 6 V
	V <sub>I</sub> (5VIN)	-0.3 V to 6 V
	V <sub>I</sub> (1.8VIN)	-0.3 V to 6 V
Logic input/output voltage		-0.3 V to 6 V
Output voltage range	V <sub>O</sub> (XVCC)	-0.3 V to 6 V
	V <sub>O</sub> (XVPP/VCORE)	-0.3 V to 6 V
Continuous total power dissipation		See Dissipation Rating Table
Output current	I <sub>O</sub> (XVCC)	Internally Limited
	I <sub>O</sub> (XVPP/VCORE)	
Operating virtual junction temperature range, T <sub>J</sub>		-40°C to 100°C
Storage temperature range, T <sub>stg</sub>		-55°C to 150°C
Lead temperature 1,6 mm (1/16 inch) from case for 10 seconds		260°C
OC sink current		10 mA

(1) Stresses beyond those listed under “absolute maximum ratings” may cause permanent damage to the device. These are stress ratings only, and functional operation of the device at these or any other conditions beyond those indicated under “recommended operating conditions” is not implied. Exposure to absolute-maximum-rated conditions for extended periods may affect device reliability.

## DISSIPATION RATINGS TABLE (THERMAL RESISTANCE = °C/W)<sup>(1)</sup>

PACKAGE <sup>(2)</sup>	DERATING FACTOR ABOVE T <sub>A</sub> = 25°C	T <sub>A</sub> ≤ 25°C POWER RATING	T <sub>A</sub> = 70°C POWER RATING	T <sub>A</sub> = 85°C POWER RATING
20-PWP	30.67 mW/°C	2300 mW	920.25 mW	460.12 mW
14-PWP	26.67 mW/°C	2000 mW	800 mW	400 mW
DB-30	10.95 mW/°C	821.47 mW	328.59 mW	164.3 mW

(1) Reference *Calculating Junction Temperature* in the application information section of this data sheet.

(2) These devices are mounted on an JEDEC low-k board (2 oz. traces on surface) (Based on the maximum recommended junction temperature of 100°C)

## RECOMMENDED OPERATING CONDITIONS

		MIN	MAX	UNIT
Input voltage, V <sub>I</sub> 3.3VIN is required for all circuit operations. 5VIN and 1.8VIN are only required for their respective functions.	V <sub>I</sub> (3.3VIN)	3.0	3.6	V
	V <sub>I</sub> (5VIN)	2.7	5.5	V
	V <sub>I</sub> (1.8VIN)	1.7	1.9	V
Output current	I <sub>O</sub> (XVCC) at T <sub>J</sub> = 100°C		1	A
	I <sub>O</sub> (XVPP/VCORE) when switched to 5VIN at T <sub>J</sub> = 100°C		100	mA
	I <sub>O</sub> (XVPP/VCORE) when switched to 3.3VIN or 1.8VIN at T <sub>J</sub> = 100°C		500	mA
Clock frequency			2.5	MHz
Pulse duration	Data	200		ns
	Latch	250		ns
	Clock	100		ns
	Reset	100		ns
Data to clock hold time (Figure 2)		100		ns
Data to clock setup time (Figure 2)		100		ns
Latch delay time (Figure 2)		100		ns
Clock delay time (Figure 2)		250		ns
Operating virtual junction temperature, T <sub>J</sub> (maximum to be calculated at worst case PD at 85°C ambient)		-40	100	°C

## ELECTRICAL CHARACTERISTICS

$T_J = -40^\circ\text{C}$  to  $100^\circ\text{C}$ ,  $V_{I(5V_{IN})} = 5\text{ V}$ ,  $V_{I(3.3V_{IN})} = 3.3\text{ V}$ ,  $V_{I(1.8V_{IN})} = 1.8\text{ V}$ , all outputs unloaded (unless otherwise noted)<sup>(1)</sup>

PARAMETER		TEST CONDITIONS	MIN	TYP	MAX	UNIT	
<b>POWER SWITCH</b>							
Switch resistance	3.3VIN to XVCC with two switches on for dual	$T_J = 25^\circ\text{C}$ , $I = 750\text{ mA}$ each		72	95	m $\Omega$	
		$T_J = 100^\circ\text{C}$ , $I = 750\text{ mA}$ each			120		
	5VIN to XVCC with two switches on for dual	$T_J = 25^\circ\text{C}$ , $I = 500\text{ mA}$ each		97	125	m $\Omega$	
		$T_J = 100^\circ\text{C}$ , $I = 500\text{ mA}$ each			160		
	1.8VIN to XVPP/VCORE with two switches on for dual	$T_J = 25^\circ\text{C}$ , $I = 375\text{ mA}$ each		69	95	m $\Omega$	
		$T_J = 100^\circ\text{C}$ , $I = 375\text{ mA}$ each			120		
	3.3VIN to XVPP/VCORE with two switches on for dual	$T_J = 25^\circ\text{C}$ , $I = 250\text{ mA}$ each		196	260	m $\Omega$	
		$T_J = 100^\circ\text{C}$ , $I = 250\text{ mA}$ each			325		
	5VIN to XVPP/VCORE with two switches on for dual	$T_J = 25^\circ\text{C}$ , $I = 100\text{ mA}$ each		0.9	1.3	$\Omega$	
		$T_J = 100^\circ\text{C}$ , $I = 100\text{ mA}$ each			1.6		
	$R_{O(XVCC)}$ discharge resistance		$I_{\text{discharge}} = 1\text{ mA}$	0.1		0.5	k $\Omega$
	$R_{O(XVPP/VCORE)}$ discharge resistance		$I_{\text{discharge}} = 1\text{ mA}$	0.1		0.5	k $\Omega$
$I_{OS}$ Short-circuit output current <sup>(1)</sup>	$I_{O(XVCC)}$ 3.3VIN or 5VIN to XVCC	Limit (limit is the steady state value.)	$T_J$ at $25^\circ\text{C}$ , output powered into a short	1	1.5	A	
			$T_J$ [ $-40, 100^\circ\text{C}$ ], output powered into a short	1	2.5		
	$I_{O(XVPP/VCORE)}$ 5VIN to XVPP/VCORE	Limit	$T_J$ at $25^\circ\text{C}$ , output powered into a short	120	175	mA	
			$T_J$ [ $-40, 100^\circ\text{C}$ ], output powered into a short	120	300		
	$I_{O(XVPP/VCORE)}$ 1.8VIN or 3.3VIN to XVPP/VCORE	Limit	$T_J$ at $25^\circ\text{C}$ , output powered into a short	500	680	mA	
			$T_J$ [ $-40, 100^\circ\text{C}$ ], output powered into a short	500	1250		
Thermal shutdown	Trip point, $T_J$	Rising temperature, not in overcurrent condition	155	165	$^\circ\text{C}$		
		Overcurrent condition	120	130			
	Hysteresis			10			
Current limit response time <sup>(2)(3)</sup>			$V_{O(XVCC)} = 5\text{ V}$ , $100\text{ m}\Omega$ short to GND, $T_J = 25^\circ\text{C}$		10	$\mu\text{s}$	
			$V_{O(XVCC)} = 3.3\text{ V}$ , $100\text{ m}\Omega$ short to GND, $T_J = 25^\circ\text{C}$		20		
			$V_{O(XVPP/VCORE)} = 5\text{ V}$ , $100\text{ m}\Omega$ short to GND, $T_J = 25^\circ\text{C}$		2		
			$V_{O(XVPP/VCORE)} = 3.3\text{ V}$ , $100\text{ m}\Omega$ short to GND, $T_J = 25^\circ\text{C}$		35		
			$V_{O(XVPP/VCORE)} = 1.8\text{ V}$ , $100\text{ m}\Omega$ short to GND, $T_J = 25^\circ\text{C}$		250		
$I_I$ Input Quiescent current	Normal operation of TPS2228	$I_{I(3.3V_{IN})}$	$V_{O(XVCC)} = V_{O(XVPP/VCORE)} = V_{I(3.3V_{IN})}$ , Output pins are floated		95	140	$\mu\text{A}$
		$I_{I(5V_{IN})}$			5	10	
		$I_{I(1.8V_{IN})}$				5	
	Normal operation of TPS2221	$I_{I(3.3V_{IN})}$	$V_{O(XVCC)} = V_{O(XVPP/VCORE)} = V_{I(3.3V_{IN})}$ , Output pins are floated		64	100	$\mu\text{A}$
		$I_{I(5V_{IN})}$			5	10	
		$I_{I(1.8V_{IN})}$				5	
	Shutdown mode (based on control data)	$I_{I(3.3V_{IN})}$	Output pins are floated			5	$\mu\text{A}$
	$V_{O(XVCC)} = \text{Hi-Z}$	$I_{I(5V_{IN})}$				5	
	$V_{O(XVPP/VCORE)} = \text{Hi-Z}$	$I_{I(1.8V_{IN})}$				5	

(1) Pulse-testing techniques maintain junction temperature close to ambient temperature; thermal effects must be taken into account separately.

(2) Specified by design, not tested in production.

(3) From application of short to 110% of final current limit.

### ELECTRICAL CHARACTERISTICS (continued)

T<sub>J</sub> = -40°C to 100°C, V<sub>I(5VIN)</sub> = 5 V, V<sub>I(3.3VIN)</sub> = 3.3 V, V<sub>I(1.8VIN)</sub> = 1.8 V, all outputs unloaded (unless otherwise noted)<sup>(1)</sup>

PARAMETER		TEST CONDITIONS	MIN	TYP	MAX	UNIT
<b>POWER SWITCH (continued)</b>						
Forward leakage current I <sub>ikg_FWD</sub> (current measured from output pins to ground)	I <sub>O(xVCC)</sub>	All switches are in Hi-Z state xVCC and xVPP/VCORE are grounded		1	10	μA
	I <sub>O(xVPP/VCORE)</sub>			1	10	
Reverse leakage current I <sub>ikg_RVS</sub> (current measured from output pins going in)	I <sub>O(3.3VIN)</sub>	All switches are in Hi-Z state, 3.3VIN, 5VIN, and 1.8VIN are grounded V <sub>O(xVPP/VCORE)</sub> = V <sub>O(xVCC)</sub> = 5 V		1	10	μA
	I <sub>O(5VIN)</sub>			1	10	
	I <sub>O(1.8VIN)</sub>			1	10	

(1) Pulse-testing techniques maintain junction temperature close to ambient temperature; thermal effects must be taken into account separately.

(2) Specified by design, not tested in production.

(3) From application of short to 110% of final current limit.

### ELECTRICAL CHARACTERISTICS

T<sub>J</sub> = -40°C to 100°C, V<sub>I(5VIN)</sub> = 5 V, V<sub>I(3.3VIN)</sub> = 3.3 V, V<sub>I(1.8VIN)</sub> = 1.8 V, all outputs unloaded (unless otherwise noted)<sup>(1)</sup>

PARAMETER		TEST CONDITIONS <sup>(1)</sup>	MIN	TYP	MAX	UNIT
<b>LOGIC SECTION (CLOCK, DATA, LATCH, RESET, SHDN, OC, VDO, VD1, VD2, VD3)</b>						
Logic input current	I( $\overline{\text{RESET}}$ ) <sup>(3)</sup>	$\overline{\text{RESET}} = 5.5 \text{ V}$ , sinking or sourcing		0	1	μA
		$\overline{\text{RESET}} = 0 \text{ V}$ , sourcing	10		30	
	I( $\overline{\text{SHDN}}$ ) <sup>(3)</sup> Or I( $\overline{\text{SHDN\_RST}}$ ) <sup>(3)</sup>	$\overline{\text{SHDN}}$ or $\overline{\text{SHDN\_RST}} = 5.5 \text{ V}$ , sinking or sourcing		0	1	
		$\overline{\text{SHDN}}$ or $\overline{\text{SHDN\_RST}} = 0 \text{ V}$ , sourcing	10		30	
	I(LATCH) <sup>(1)</sup>	LATCH = 5.5 V, sinking			50	
LATCH = 0 V, sinking or sourcing				1		
	I(CLOCK, DATA, VDO, VD1, VD2, VD3)	0 V to 5.5 V, sinking or sourcing			1	
Logic input high level <sup>(4)</sup>			2			V
Logic input low level <sup>(4)</sup>					0.8	
OC output saturation voltage		I <sub>O</sub> = 2 mA			0.4	
OC leakage current		V <sub>O(OC)</sub> = 5.5 V			1	μA
OC deglitch <sup>(2)</sup>	Falling edge	Falling into overcurrent condition	5		15	mS
	Rising edge	Coming out of overcurrent condition	5		15	

PARAMETER		TEST CONDITIONS <sup>(1)</sup>	MIN	TYP	MAX	UNIT
<b>UVLO</b>						
3.3VIN UVLO		3.3VIN level below which all switches are in Hi-Z state	2.2		2.9	V
3.3VIN Hysteresis <sup>(2)</sup>				0.1		
5VIN UVLO		5VIN level below which only 5VIN switches are in Hi-Z state	2.0		2.6	mV
5VIN Hysteresis <sup>(2)</sup>				80		
1.8VIN UVLO		1.8VIN level below which only 1.8VIN switches are in Hi-Z state	1.25		1.62	V
1.8VIN Hysteresis <sup>(2)</sup>				50		mV

(1) Refer to Parameter Measurement Information, Figure 1.

(2) Specified by design, not tested in production.

(3) RESET and SHDN (or SHDN/RST for TPS2221) have low current pullup; LATCH has low current pulldown.

(4) For recommended operating ranges only.

## ELECTRICAL CHARACTERISTICS

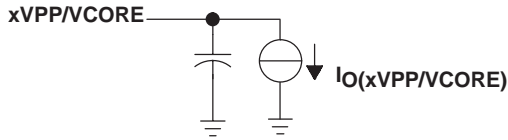
$T_J = -40^\circ\text{C}$  to  $100^\circ\text{C}$ ,  $V_I(5\text{VIN}) = 5\text{ V}$ ,  $V_I(3.3\text{VIN}) = 3.3\text{ V}$ ,  $V_I(1.8\text{VIN}) = 1.8\text{ V}$ , all outputs unloaded (unless otherwise noted)(1)

PARAMETER(1)		TEST CONDITIONS(1)		MIN	TYP	MAX	UNIT	
<b>SWITCHING CHARACTERISTICS</b>								
$t_r$ Output rise times(2)	5VIN to xVCC	$C_L(xVCC) = 0.1\ \mu\text{F}$ , $I_O(xVCC) = 0\ \text{A}$ ,		0.5		2	ms	
	3.3VIN to xVCC			0.5		2		
	1.8VIN to xVPP/VCORE	$C_L(xVPP/VCORE) = 0.1\ \mu\text{F}$ , $I_O(xVPP/VCORE) = 0\ \text{A}$		0.5		2		
	3.3VIN to xVPP/VCORE			0.15		1		
	5VIN to xVPP/VCORE	$C_L(xVPP/VCORE) = 0.1\ \mu\text{F}$ , $I_O(xVPP/VCORE) = 0\ \text{A}$		0.05		0.14		
	5VIN to xVCC			$C_L(xVCC) = 150\ \mu\text{F}$ , $I_O(xVCC) = 0.75\text{A}$		0.75		
	3.3VIN to xVCC	0.75				2.0		
	1.8VIN to xVPP/VCORE	$C_L(xVPP/VCORE) = 150\ \mu\text{F}$ , $I_O(xVPP/VCORE) = 0.375\text{A}$		0.50		2.0		
	3.3VIN to xVPP/VCORE			0.50		1.15		
	5VIN to xVPP/VCORE	$C_L(xVPP/VCORE) = 10\ \mu\text{F}$ , $I_O(xVPP/VCORE) = 0.05\text{A}$		0.15		0.375		
$t_f$ Output fall times(2)	5VIN to xVCC	$C_L(xVCC) = 0.1\ \mu\text{F}$ , $I_O(xVCC) = 0\ \text{A}$ ,		0.25		1.0	ms	
	3.3VIN to xVCC			0.35		1.0		
	1.8VIN to xVPP/VCORE	$C_L(xVCC) = 0.1\ \mu\text{F}$ , $I_O(xVCC) = 0\ \text{A}$ ,		0.25		1.0		
	3.3VIN to xVPP/VCORE			0.1		0.5		
	5VIN to xVPP/VCORE	$C_L(xVPP/VCORE) = 0.1\ \mu\text{F}$ , $I_O(xVPP/VCORE) = 0\ \text{A}$		0.075		0.15		
	5VIN to xVCC	$C_L(xVCC) = 150\ \mu\text{F}$ , $I_O(xVCC) = 0.75\text{A}$		1.4		2.5		
	3.3VIN to xVCC			1.4		1.7		
	1.8VIN to xVPP/VCORE	$C_L(xVCC) = 150\ \mu\text{F}$ , $I_O(xVPP/VCORE) = 0.375\ \text{A}$		1.4		2.0		
	3.3VIN to xVPP/VCORE			2.5		3.1		
	5VIN to xVPP/VCORE	$C_L(xVPP/VCORE) = 10\ \mu\text{F}$ , $I_O(xVPP/VCORE) = 0.05\ \text{A}$		1.7		2.1		
$t_{pd}$ Propagation delay(2)	Latch $\uparrow$ to xVPP/VCORE (1.8 V)	$C_L(xVPP/VCORE) = 0.1\ \mu\text{F}$ , $I_O(xVPP/VCORE) = 0\ \text{A}$		$t_{pdon}$	0.15		1.4	ms
				$t_{pdoff}$	2.5		8.6	
	Latch $\uparrow$ to xVPP/VCORE (3.3 V)	$C_L(xVPP/VCORE) = 0.1\ \mu\text{F}$ , $I_O(xVPP/VCORE) = 0\ \text{A}$		$t_{pdon}$	0.05		0.5	
				$t_{pdoff}$	0.5		2.5	
	Latch $\uparrow$ to xVPP/VCORE (5 V)	$C_L(xVPP/VCORE) = 0.1\ \mu\text{F}$ , $I_O(xVPP/VCORE) = 0\ \text{A}$		$t_{pdon}$	0.02		0.3	
				$t_{pdoff}$	0.10		0.3	
	Latch $\uparrow$ to xVCC (5 V)	$C_L(xVCC) = 0.1\ \mu\text{F}$ , $I_O(xVCC) = 0\ \text{A}$		$t_{pdon}$	0.15		0.85	
				$t_{pdoff}$	1.3		3.7	
	Latch $\uparrow$ to xVCC (3.3 V)	$C_L(xVCC) = 0.1\ \mu\text{F}$ , $I_O(xVCC) = 0\ \text{A}$		$t_{pdon}$	0.15		1.0	
				$t_{pdoff}$	1.7		5.3	
$t_{pd}$ Propagation delay(2)	Latch $\uparrow$ to xVPP/VCORE (1.8 V)	$C_L(xVPP/VCORE) = 150\ \mu\text{F}$ , $I_O(xVPP/VCORE) = 0.375\ \text{A}$		$t_{pdon}$	0.35		1.9	ms
				$t_{pdoff}$	2.4		8.5	
	Latch $\uparrow$ to xVPP/VCORE (3.3 V)	$C_L(xVPP/VCORE) = 150\ \mu\text{F}$ , $I_O(xVPP/VCORE) = 0.375\ \text{A}$		$t_{pdon}$	0.2		0.75	
				$t_{pdoff}$	0.5		2.5	
	Latch $\uparrow$ to xVPP/VCORE (5 V)	$C_L(xVPP/VCORE) = 10\ \mu\text{F}$ , $I_O(xVPP/VCORE) = 0.05\ \text{A}$		$t_{pdon}$	0.05		0.15	
				$t_{pdoff}$	0.15		0.35	
	Latch $\uparrow$ to xVCC (5 V)	$C_L(xVCC) = 150\ \mu\text{F}$ , $I_O(xVCC) = 0.75\ \text{A}$		$t_{pdon}$	0.35		1.2	
				$t_{pdoff}$	1.3		3.7	
	Latch $\uparrow$ to xVCC (3.3 V),	$C_L(xVCC) = 150\ \mu\text{F}$ , $I_O(xVCC) = 0.75\ \text{A}$		$t_{pdon}$	0.4		1.4	
				$t_{pdoff}$	1.5		5.2	

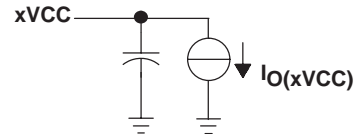
(1) Refer to Parameter Measurement Information, Figure 1.

(2) Specified by design, not tested in production

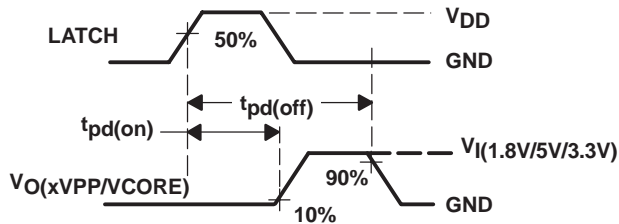
PARAMETER MEASUREMENT INFORMATION



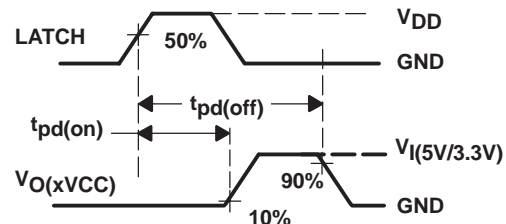
LOAD CIRCUIT (xVPP/VCORE)



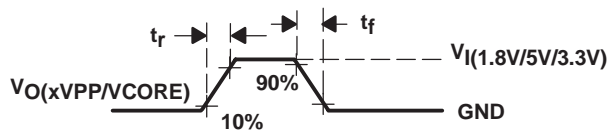
LOAD CIRCUIT (xVCC)



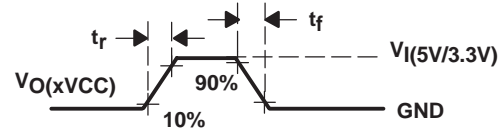
Propagation Delay (xVPP)



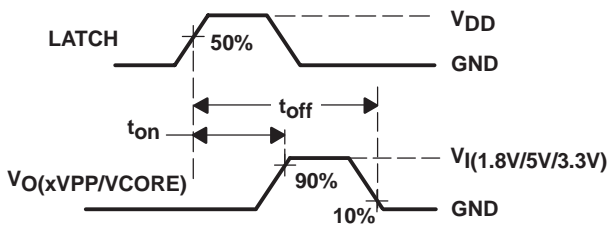
Propagation Delay (xVCC)



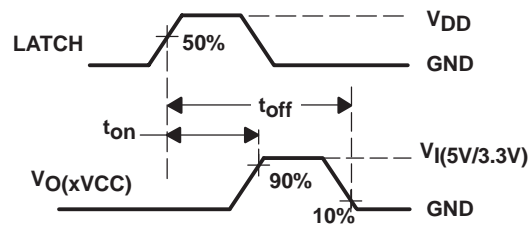
Rise/Fall Time (xVPP)



Rise/Fall Time (xVCC)



Turn On/Off Time (xVPP)

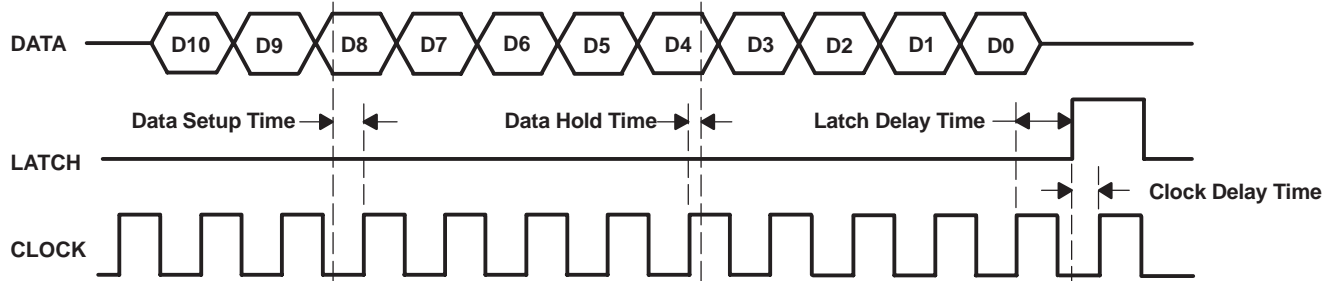


Turn On/Off Time (xVCC)

VOLTAGE WAVEFORMS

Figure 1. Test Circuits and Voltage Waveforms

**PARAMETER MEASUREMENT INFORMATION**



NOTE: Data is clocked in on the positive edge of the clock. The positive edge of the latch signal should occur before the next positive edge of the clock. For definition of D0 to D10, see the control logic table.

**Figure 2. Serial-Interface Timing for TPS2228/TPS2221 Power Interface Switch**

**TABLE OF GRAPHS FOR POWER MEASUREMENT INFORMATION**

		<b>FIGURE</b>
Short-Circuit Current Response, Short Applied to Powered-on 5VIN-to-xVCC Switch Output	vs Time	3
Short-Circuit Current Response, Short Applied to Powered-on 3.3VIN-to-xVCC Switch Output	vs Time	4
OC Response With 5VIN-to-xVCC Switch Output Turned on Into a Short	vs Time	5
OC Response With 3.3VIN-to-xVCC Switch Output Turned on Into a Short	vs Time	6
3.3VIN and 5VIN Input Current	vs Junction Temperature	7
3.3VIN and 5VIN Input Current	vs Junction Temperature	8
1.8VIN Input Current	vs Junction Temperature	9
Static Drain-Source On-State Resistance, 3.3VIN to xVCC Switch	vs Junction Temperature	10
Static Drain-Source On-State Resistance, 5VIN to xVCC Switch	vs Junction Temperature	11
Static Drain-Source On-State Resistance, 3.3VIN to xVPP/VCORE Switch	vs Junction Temperature	12
Static Drain-Source On-State Resistance, 5VIN to xVPP/VCORE Switch	vs Junction Temperature	13
Static Drain-Source On-State Resistance, 1.8VIN to xVPP/VCORE Switch	vs Junction Temperature	14
Short-Circuit Current Limit, 3.3VIN to xVCC Switch	vs Junction Temperature	15
Short-Circuit Current Limit, 5VIN to xVCC Switch	vs Junction Temperature	16
Short-Circuit Current Limit, 3.3VIN to xVPP/VCORE Switch	vs Junction Temperature	17
Short-Circuit Current Limit, 5VIN to xVPP/VCORE Switch	vs Junction Temperature	18
Short-Circuit Current Limit, 1.8VIN to xVPP/VCORE Switch	vs Junction Temperature	19

PARAMETER MEASUREMENT INFORMATION

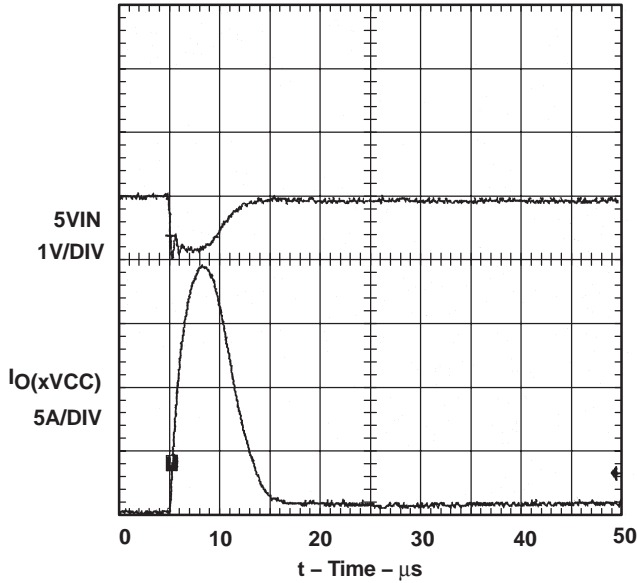


Figure 3. Short-Circuit Response, Short Applied to Powered-on 5VIN-to-xVCC Switch Output

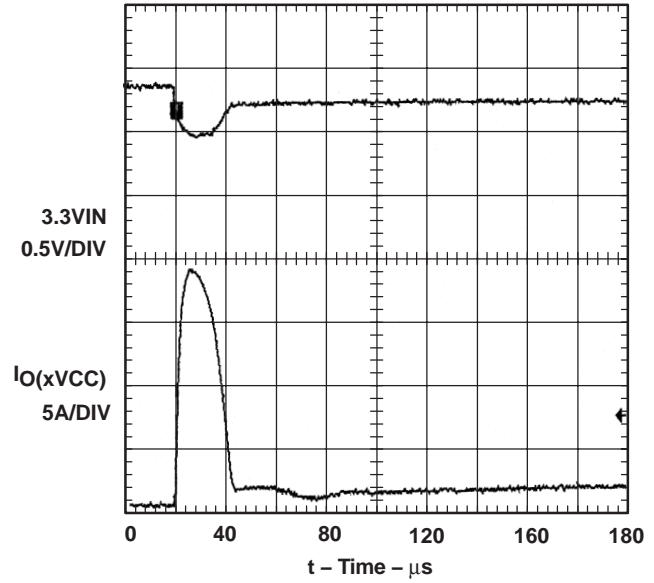


Figure 4. Short-Circuit Response, Short Applied to Powered-on 3.3VIN-to-xVCC-Switch Output

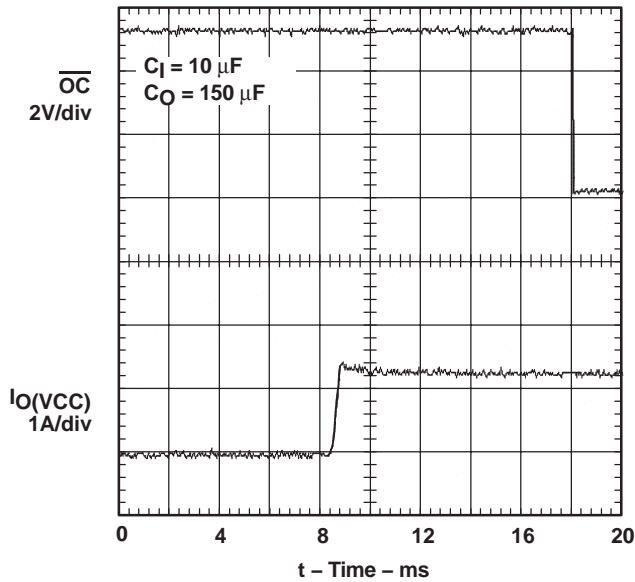


Figure 5. OC Response With 5VIN-to-xVCC Switch Output Turned on Into a Short

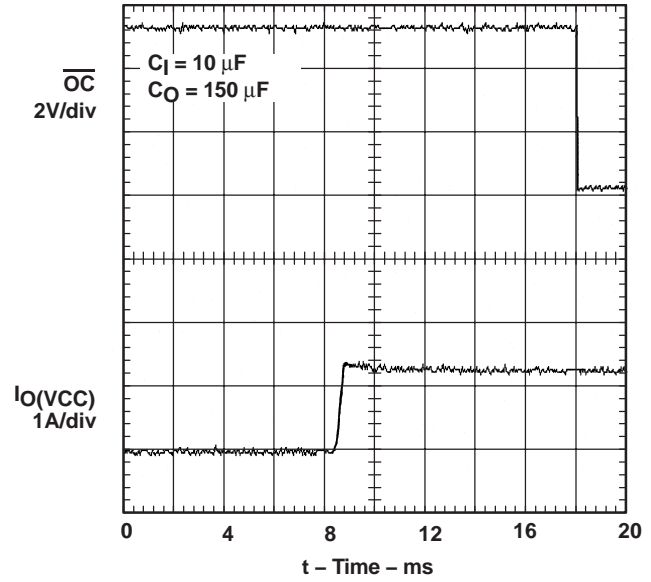
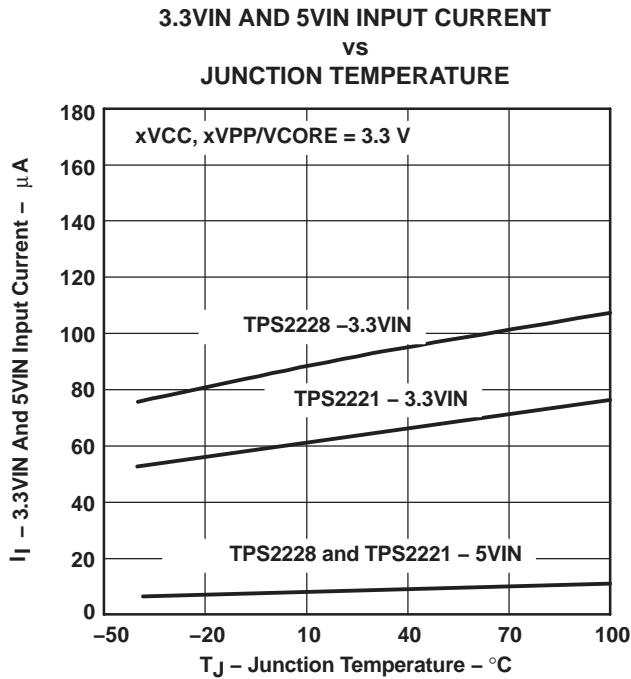


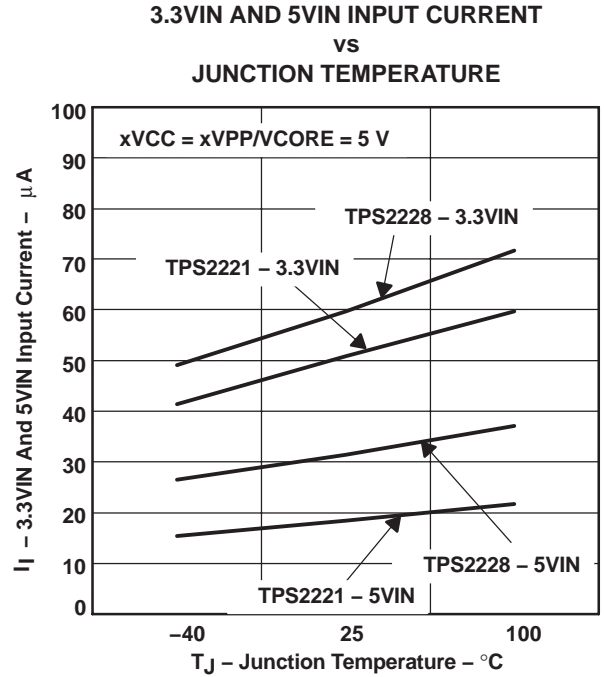
Figure 6. OC Response With 3.3VIN-to-xVCC Switch Output Turned on Into a Short



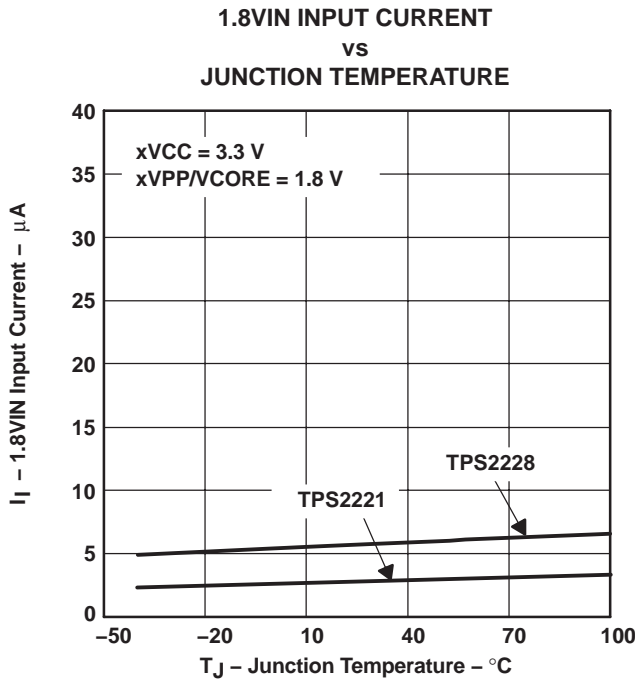
**PARAMETER MEASUREMENT INFORMATION**



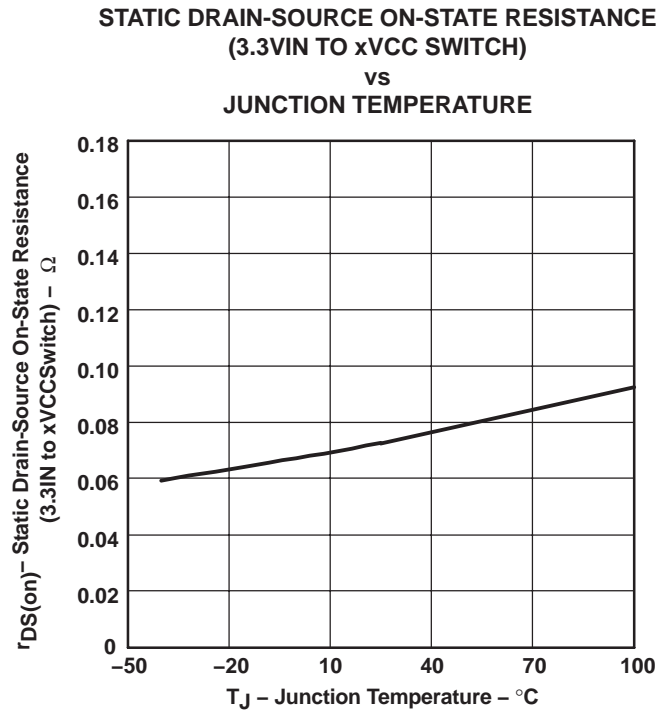
**Figure 7**



**Figure 8**



**Figure 9**



**Figure 10**

PARAMETER MEASUREMENT INFORMATION

STATIC DRAIN-SOURCE ON-STATE RESISTANCE  
(5VIN TO xVCC SWITCH)  
vs  
JUNCTION TEMPERATURE

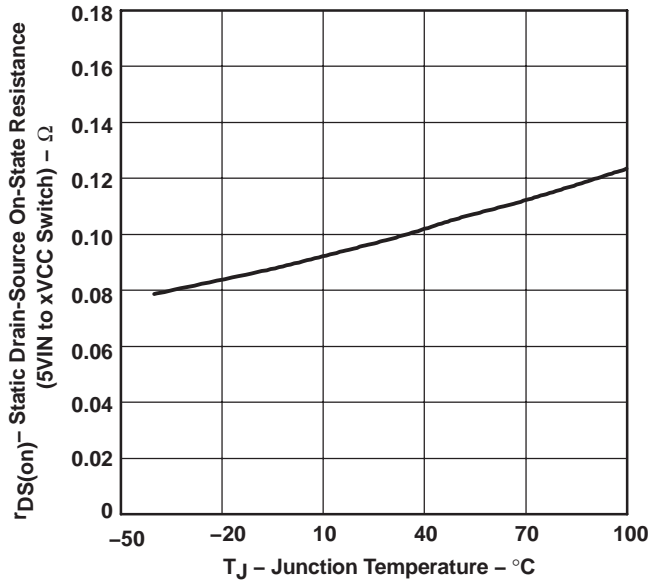


Figure 11

STATIC DRAIN-SOURCE ON-STATE RESISTANCE  
(3.3VIN TO xVPP/VCORE SWITCH)  
vs  
JUNCTION TEMPERATURE

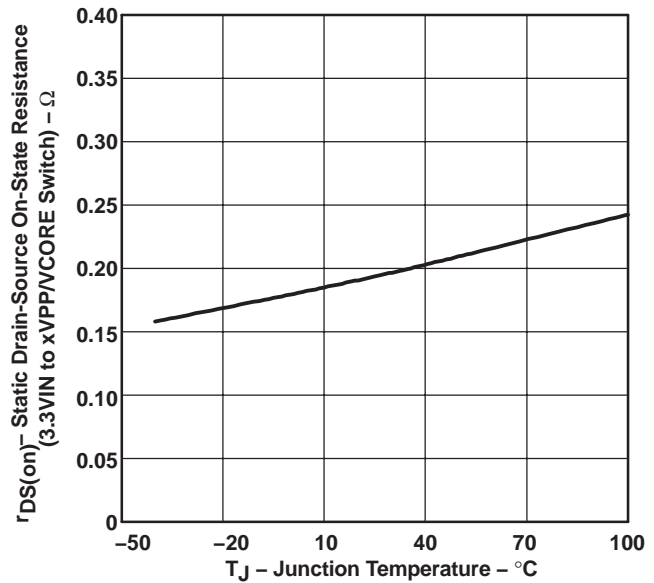


Figure 12

STATIC DRAIN-SOURCE ON-STATE RESISTANCE  
(5VIN TO xVPP/VCORE SWITCH)  
vs  
JUNCTION TEMPERATURE

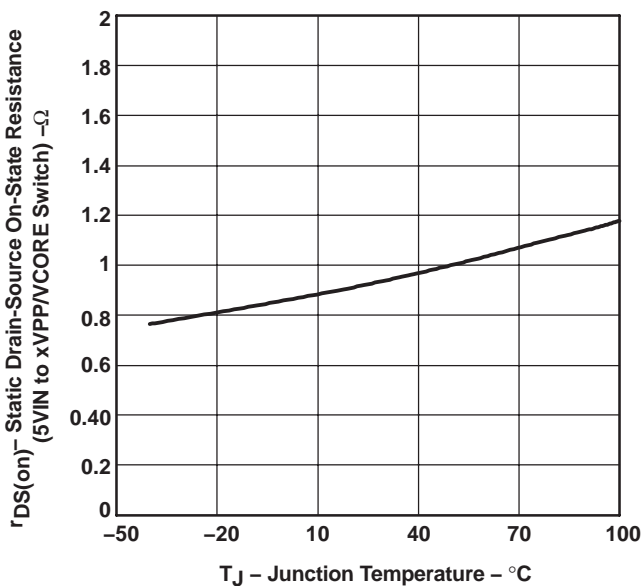


Figure 13

STATIC DRAIN-SOURCE ON-STATE RESISTANCE  
(1.8VIN TO xVPP/VCORE SWITCH)  
vs  
JUNCTION TEMPERATURE

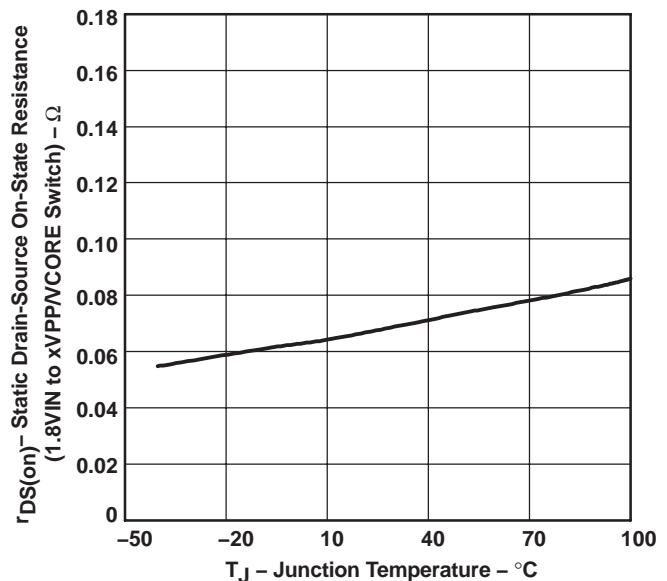
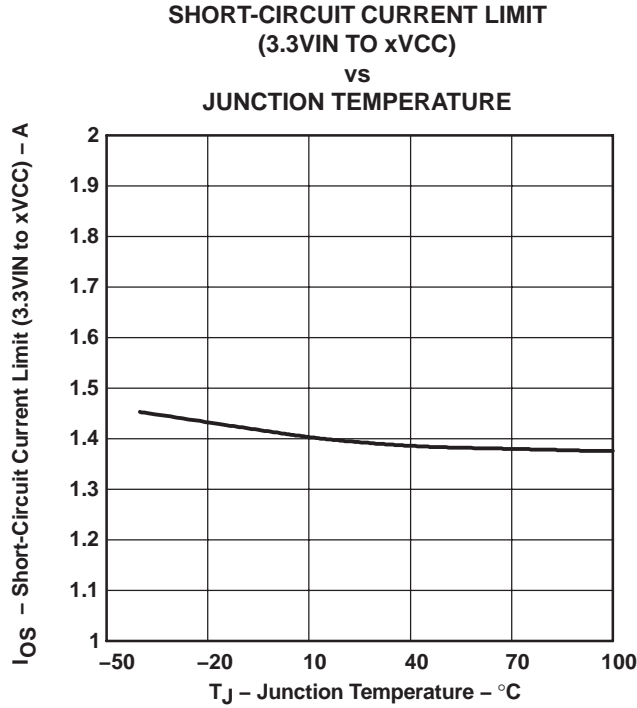
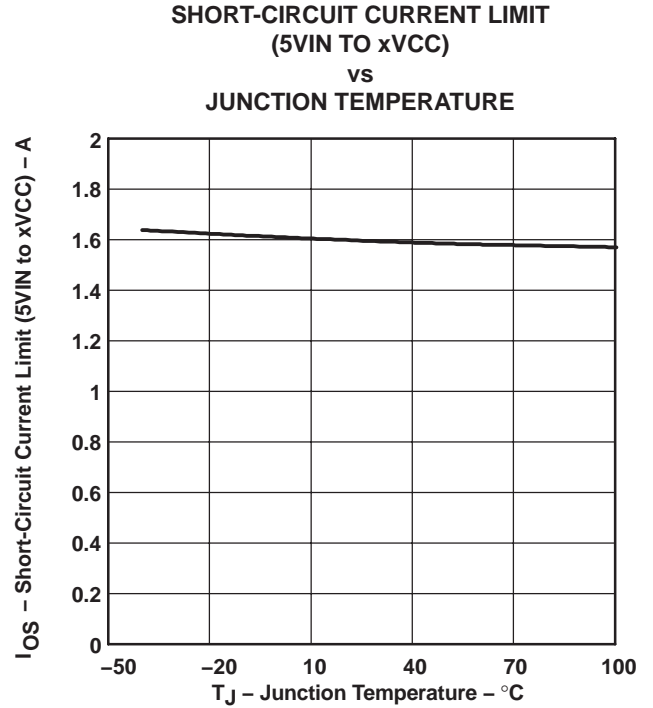


Figure 14

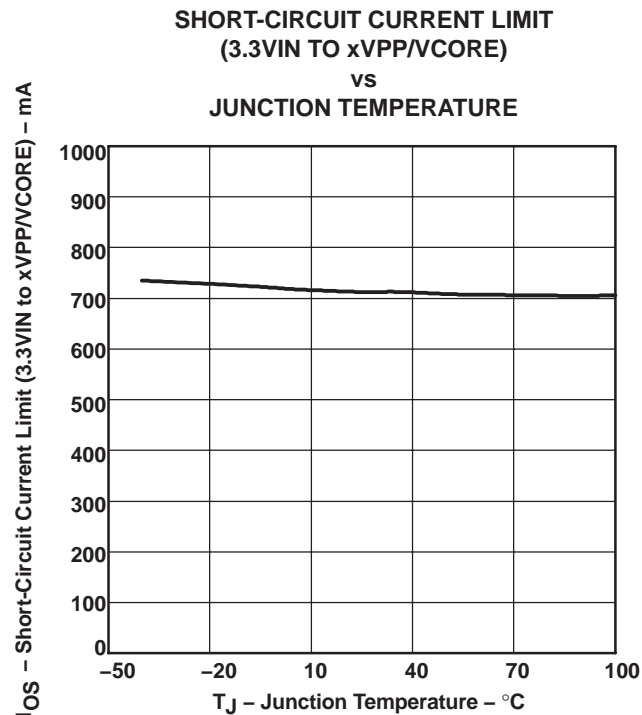
**PARAMETER MEASUREMENT INFORMATION**



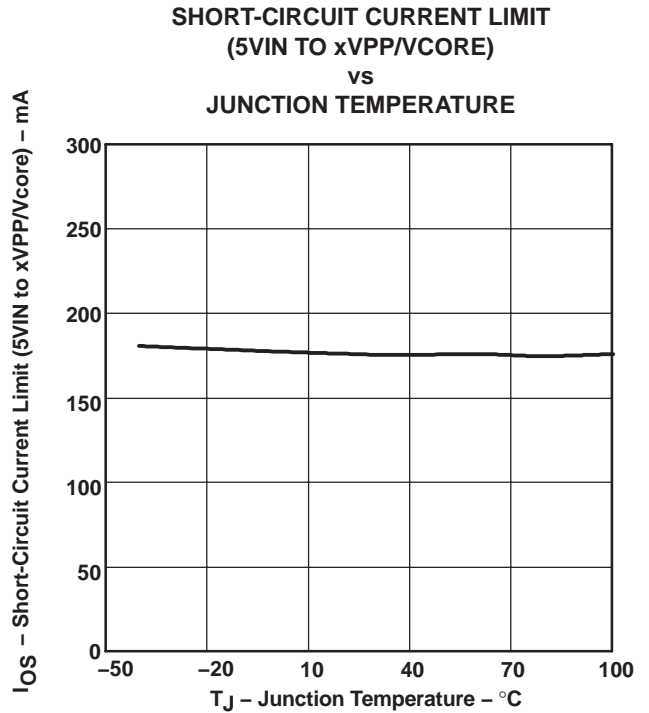
**Figure 15**



**Figure 16**

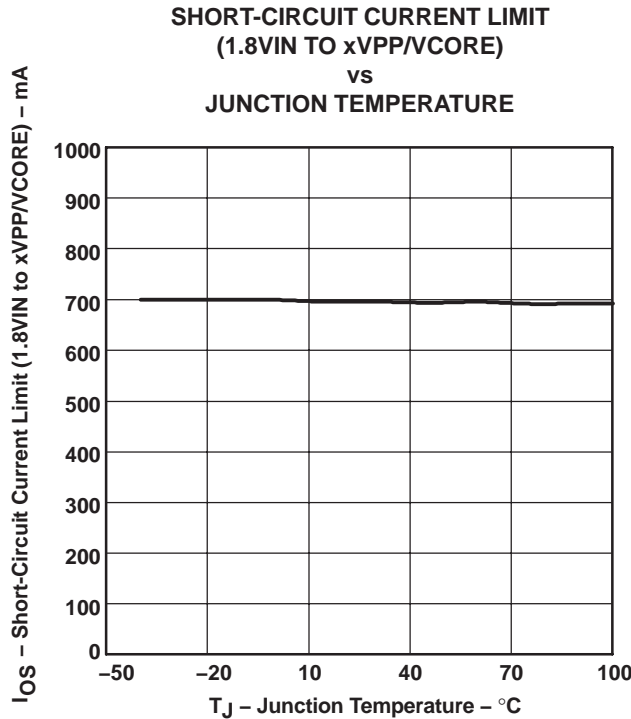


**Figure 17**



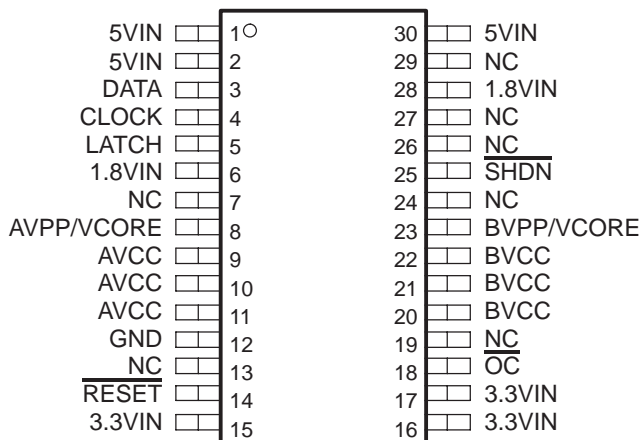
**Figure 18**

**PARAMETER MEASUREMENT INFORMATION**

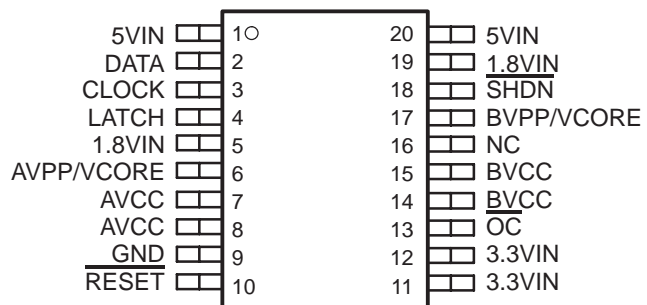


**PIN ASSIGNMENTS**

**TPS2228DB**

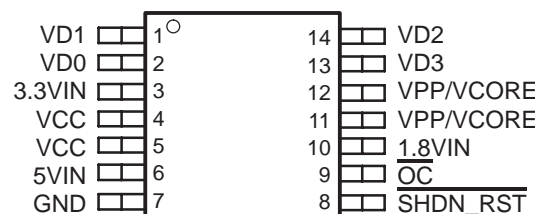


**TPS2228PWP**



NC – No internal connection

**TPS2221PWP**



## PARAMETER MEASUREMENT INFORMATION

### Terminal Functions (Dual-Serial)

TERMINAL			I/O	DESCRIPTION
NAME	NO.			
	2228 (DB-30)	2228 (PWP-20)		
1.8VIN	6, 28	5, 19	I	1.8-V input for card power (xVPP/VCORE). Pins 6 and 28 must be connected together externally.
3.3VIN	15, 16, 17	11, 12	I	3.3-V input for card power (xVCC and xVPP/Vcore) and chip power (3.3VIN must be connected to a voltage source for the device to operate)
5VIN	1, 2, 30	1, 20	I	5-V input for card power (xVCC and xVPP/Vcore)
AVCC	9, 10, 11	7, 8	O	Switched output that delivers 0 V, 3.3 V, 5 V, or high impedance to card
AVPP/VCORE	8	6	O	Switched output that delivers 0 V, 1.8 V, 3.3 V, 5 V, or high impedance to card
BVCC	20, 21, 22	14, 15	O	Switched output that delivers 0 V, 3.3 V, 5 V, or high impedance to card
BVPP/VCORE	23	17	O	Switched output that delivers 0 V, 1.8 V, 3.3 V, 5 V, or high impedance to card
CLOCK	4	3	I	Logic-level clock for serial data word
DATA	3	2	I	Logic-level serial data word
GND	12	9		Ground
LATCH	5	4	I	Logic-level latch for serial data word, an internal pulldown is provided
NC	7, 13, 19, 24, 26, 27, 29	16		No internal connection
$\overline{\text{OC}}$	18	13	O	Open-drain output that is asserted low when an overcurrent condition exists.
$\overline{\text{RESET}}$	14	10	I	Logic-level RESET input. Asynchronous command active low. An internal pullup is provided. When active, all line switches are off and all the output discharge switches are on.
$\overline{\text{SHDN}}$	25	18	I	Hi-Z (open) all switches. Identical function to serial shutdown with D8=0. Asynchronous command active low. An internal pullup is provided.

### Terminal Functions (Single - Parallel)

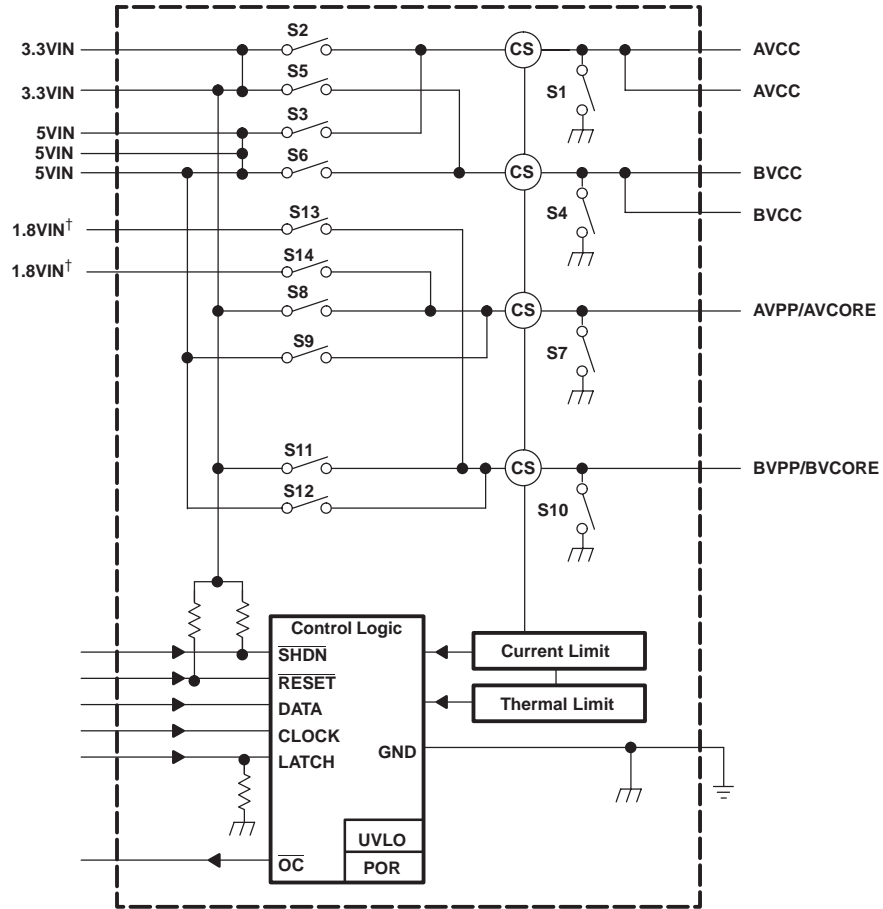
TERMINAL			I/O	DESCRIPTION
NAME	NO.			
	2221 (PWP-14)			
1.8VIN	10		I	1.8-V input for card power (VPP/VCORE)
3.3VIN	3		I	3.3-V input for card power (VCC and VPP/Vcore) and chip power (3.3VIN must be connected to a voltage source for the device to operate)
5VIN	6		I	5-V input for card power (VCC and VPP/Vcore)
GND	7			Ground
$\overline{\text{OC}}$	9		O	Open-drain output that is asserted low when an overcurrent condition exists.
$\overline{\text{SHDN\_RST}}$	8		I	Hi-Z (open) all switches. Identical function to serial shutdown mode by parallel data VD (3:0). Asynchronous command active low. An internal pullup is provided.
VCC	4, 5		O	Switched output that delivers 0 V, 3.3 V, 5 V, or high impedance to card
VD0	2		I	Parallel control signal 0 (see Table 2. TPS2221 Control Logic)
VD1	1		I	Parallel control signal 1 (see Table 2. TPS2221 Control Logic)
VD2	14		I	Parallel control signal 2 (see Table 2. TPS2221 Control Logic)
VD3	13		I	Parallel control signal 3 (see Table 2. TPS2221 Control Logic)
VPP/VCORE	11, 12		O	Switched output that delivers 0 V, 1.8 V, 3.3 V, 5 V, or high impedance to card

**TPS2228**  
**TPS2221**

SLVS419A – MAY 2002 REVISED SEPTEMBER 2002

**FUNCTIONAL BLOCK DIAGRAM**

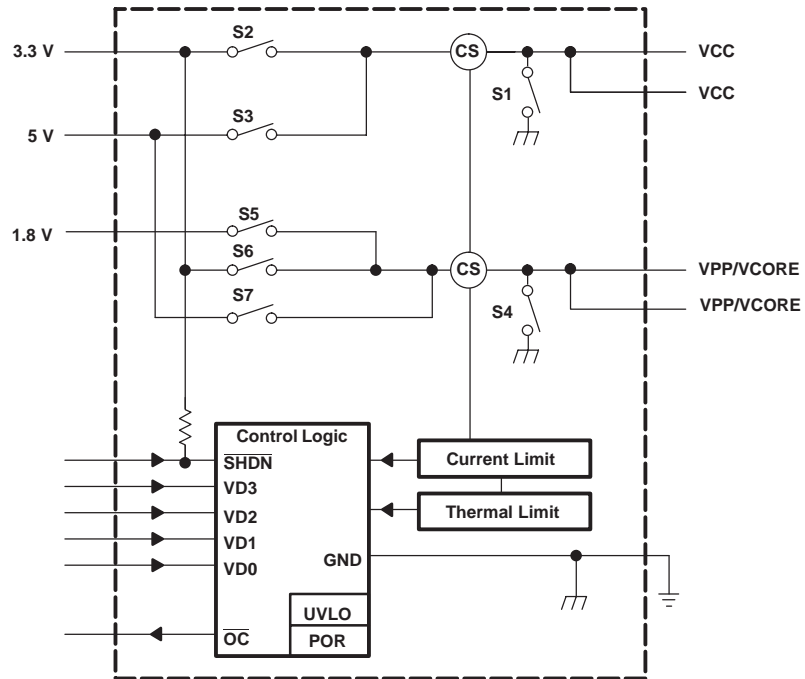
**DUAL WITH SERIAL INTERFACE**



† The two 1.8VIN pins must be connected together externally

## FUNCTIONAL BLOCK DIAGRAM

### SINGLE WITH PARALLEL INTERFACE



## APPLICATION INFORMATION

### OVERVIEW

PC cards were initially introduced as a means to add EEPROM (flash memory) to portable computers with limited onboard memory. The idea of add-in cards quickly took hold; modems, wireless LANs, GPS systems, multimedia, and hard-disk versions were soon available. As the number of PC card applications grew, the engineering community quickly recognized the need for a standard to ensure compatibility across platforms. As a result, the PCMCIA (Personal Computer Memory Card International Association) was established, comprised of members from leading computer, software, PC card, and semiconductor manufacturers. One key goal was to realize the *plug-and-play* concept, so that cards and hosts from different vendors could communicate with one another transparently.

### PC CARD POWER SPECIFICATION

The current PC card standard set forth by the PCMCIA committee states that power is to be transferred between the host and the card through eight of the PC card connector's 68 terminals. This power interface consists of two  $V_{CC}$ , two  $V_{PP}/V_{CORE}$ , and four ground terminals. Multiple power and ground terminals minimize connector-terminal and line resistance. The two  $V_{pp}/V_{core}$  terminals were originally specified as separate signals, but the host is no longer required to provide separate programmable voltages on each pin. Primary power for the card is supplied through the  $V_{CC}$  terminals; flash-memory programming and erase voltage is supplied through the  $V_{PP}/V_{CORE}$  terminals. The  $V_{PP}/V_{CORE}$  terminals are also intended to be used as a supplemental source of power, such as a core voltage for integrated circuits.

### OVERCURRENT AND OVER TEMPERATURE PROTECTION

PC cards are inherently subject to damage caused by mishandling. Host systems require protection against short-circuited cards that could lead to power supply or PCB trace damage. Even systems sufficiently robust to withstand a short circuit would still undergo rapid battery discharge into the damaged PC card, resulting in the rather sudden and unacceptable loss of system power. The TPS2228/2221 power interface switch is designed to respond quickly to an overcurrent condition to protect the system. During an overcurrent event, the current limit circuit of the TPS2228/2221 generates an internal error signal that linearly limits the output current of the affected output. The propagation delay associated with activating the current-limit circuit has an effect on the amount of current initially delivered to the output. During this time, the

input voltage to the switch may droop a small amount. The amount of voltage droop is system dependent. Power supply bulk capacitors play an important role in minimizing this voltage droop.

Overcurrent sensing is applied to each output separately. As a result, only the affected output is current-limited during an overcurrent event. The TPS2228/2221 also has an overcurrent status output ( $\overline{OC}$ ) that is asserted low to provide feedback that an overcurrent condition has occurred.

The TPS2228/2221 has two thermal shutdown circuits. The higher thermal shutdown circuit protects the device from a high junction temperature condition. In the event that the junction temperature exceeds a minimum of 155°C, the higher thermal shutdown circuit turns off all switches to protect the device. Normal switch operation resumes when the junction temperature cools down approximately 10°C.

In the event of an overcurrent condition, the lower thermal shutdown circuit activates when the junction temperature exceeds a minimum of 120°C. On the TPS2221, this lower thermal shutdown circuit disables both the  $V_{CC}$  and the  $V_{PP}/V_{CORE}$  switches once the junction temperature exceeds the lower thermal trip point. On the TPS2228, only the channel in overcurrent (either  $AV_{CC}$  and  $AV_{PP}/V_{CORE}$ , or  $BV_{CC}$  and  $BV_{PP}/V_{CORE}$ ) is disabled. For both the TPS2221 and the TPS2228, normal operation of the switches resumes once the junction temperature cools down approximately 10°C. This cycle continues until the overcurrent condition is removed.

### VOLTAGE TRANSITIONING REQUIREMENT

PC cards, like portables, are migrating from 5 V to 3.3 V and even 1.8 V to minimize power consumption, optimize board space, and increase logic speeds. The TPS2228/2221 power interface switch is designed to meet all combinations of power delivery as currently defined in the PC card standard. The latest protocol accommodates mixed 3.3 V/ 5 V systems by first powering the card with 5 V, then polling it to determine if it is compatible with 3.3-V power. The PC card standard requires that the capacitors on 3.3-V compatible cards be discharged to below 0.8 V before applying 3.3 V power. This ensures that sensitive 3.3-V circuitry is not subjected to any residual 5-V charge and functions as a power reset. The PC card standard requires that  $V_{CC}$  be discharged within 100 ms. PC card resistance can not be relied on to provide a discharge path for voltages stored on PC card capacitance because of possible high-impedance isolation by power-management schemes. The TPS2228/2221 power interface switch includes discharge transistors on all  $V_{CC}$  and  $V_{PP}/V_{CORE}$  outputs to meet the specification requirement.



## SHUTDOWN MODE

In the shutdown mode, each of the  $V_{CC}$  and  $V_{PP}/V_{CORE}$  outputs is forced to a high-impedance state (Hi-Z). In this mode, the chip quiescent current is reduced to conserve battery power.

## POWER SUPPLY CONSIDERATIONS

The TPS2228/2221 power interface switch has multiple pins for each of its power inputs and for the switched  $V_{CC}$  outputs. The two 1.8VIN pins must be connected together externally. It is recommended that all input and output power pins be parallel connected for optimum operation.

To increase the noise immunity of the TPS2228/2221 power interface switch, the power supply inputs should have a minimum of 1 $\mu$ F electrolytic or tantalum bypass capacitor connected in parallel with a 0.047  $\mu$ F to 0.1  $\mu$ F ceramic capacitor. It is strongly recommended that the switched outputs be bypassed with a 0.1  $\mu$ F or larger ceramic capacitor. Doing so improves the immunity of the TPS2228/2221 power interface switch to electrostatic discharge (ESD). Care should be taken to minimize the inductance of PCB traces between the TPS2228/2221 power interface switch and the load.

## RESET

To ensure that cards are in a known state after power brownouts or system initialization, the PC cards should be reset at the same time via the host, by applying low impedance paths from  $V_{CC}$  and  $V_{PP}/V_{CORE}$  terminals to ground. A low-impedance output state allows discharging of residual voltage remaining on PC card filter capacitance, permitting the system (host and PC cards) to be powered up concurrently. The active low  $\overline{\text{RESET}}$  input will program all outputs to 0 V. The TPS2228 power interface switch remains in the low-impedance output state until the signal is deasserted and new data is received. For the TPS2228, the input serial data cannot be latched during reset mode.

## CALCULATING JUNCTION TEMPERATURE

The switch resistance,  $r_{DS(on)}$ , is dependent on the junction temperature,  $T_J$ , of the die. The junction temperature is dependent on both  $r_{DS(on)}$  and the current through the switch. To calculate  $T_J$ , first find  $r_{DS(on)}$  from Figures 10 through 14 using an initial temperature estimate about 50°C above ambient. Then calculate the power dissipation for each switch, using the formula:

$$P_D = r_{DS(on)} \times I^2$$

Next, sum the power dissipation and calculate the junction temperature:

$$T_J = \left( \sum P_D \times R_{\theta JA} \right) + T_A$$

Where  $R_{\theta JA}$  is the inverse of the derating factor in the dissipation rating table.

Compare the calculated junction temperature with the initial temperature estimate. If the temperatures are not within a few degrees of each other, recalculate using the calculated temperature as the initial estimate.

## LOGIC INPUTS AND OUTPUTS

For the TPS2228, the serial interface consists of DATA, CLOCK, and LATCH signals. The data is clocked in on the positive leading edge of the clock (see Figure 2). The 11-bit (D0–D10) serial data word is loaded during the positive edge of the latch signal. The latch signal should occur before the next positive leading edge of the clock.

The serial interface of the TPS2228 power interface switch is designed to be compatible with serial-interface PCMCIA controllers and current PCMCIA and Japan Electronic Industry Development Association (JEIDA) standards.

For the TPS2221, the parallel interface consists of four bits (D3:D0). These four bits must be driven continuously to select the desired voltage outputs based on the input bit pattern. During power up, these inputs can be connected to an external pulldown resistor to ensure that the outputs are at zero volts, especially if the device driving these inputs is in a high impedance state while initializing.

An overcurrent output ( $\overline{OC}$ ) is provided to indicate an overcurrent or over-temperature condition in any of the  $V_{CC}$  and  $V_{PP}/V_{CORE}$  outputs as previously discussed.

## ESD PROTECTION

All TPS2228/2221 power interface switch inputs and outputs incorporate ESD-protection circuitry designed to withstand a 2-kV human-body-model discharge as defined in MIL-STD-883C, Method 3015. The  $V_{CC}$  and  $V_{PP}/V_{CORE}$  outputs can be exposed to potentially higher discharges from the external environment through the PC card connector. Bypassing the outputs with 0.1- $\mu$ F capacitors protects the devices from discharges up to 10 kV.

**Table 1. TPS2228 Power Interface Switch Control Logic**

TPS2228 Serial Interface									
xVPP/VCORE									
D8(SHDN)	AVPP/VCORE CONTROL SIGNALS			OUTPUT V_AVPP/ VCORE	BVPP/VCORE CONTROL SIGNALS				OUTPUT V_BVPP/ VCORE
	D0	D1	D9		D8(SHDN)	D4	D5	D10	
1	0	0	X	0 V	1	0	0	X	0 V
1	0	1	0	3.3 V	1	0	1	0	3.3 V
1	0	1	1	5 V	1	0	1	1	5 V
1	1	0	X	Hi-Z	1	1	0	X	Hi-Z
1	1	1	0	1.8 V	1	1	1	0	1.8 V
1	1	1	1	1.8 V	1	1	1	1	1.8 V
0	X	X	X	Hi-Z	0	X	X	X	Hi-Z

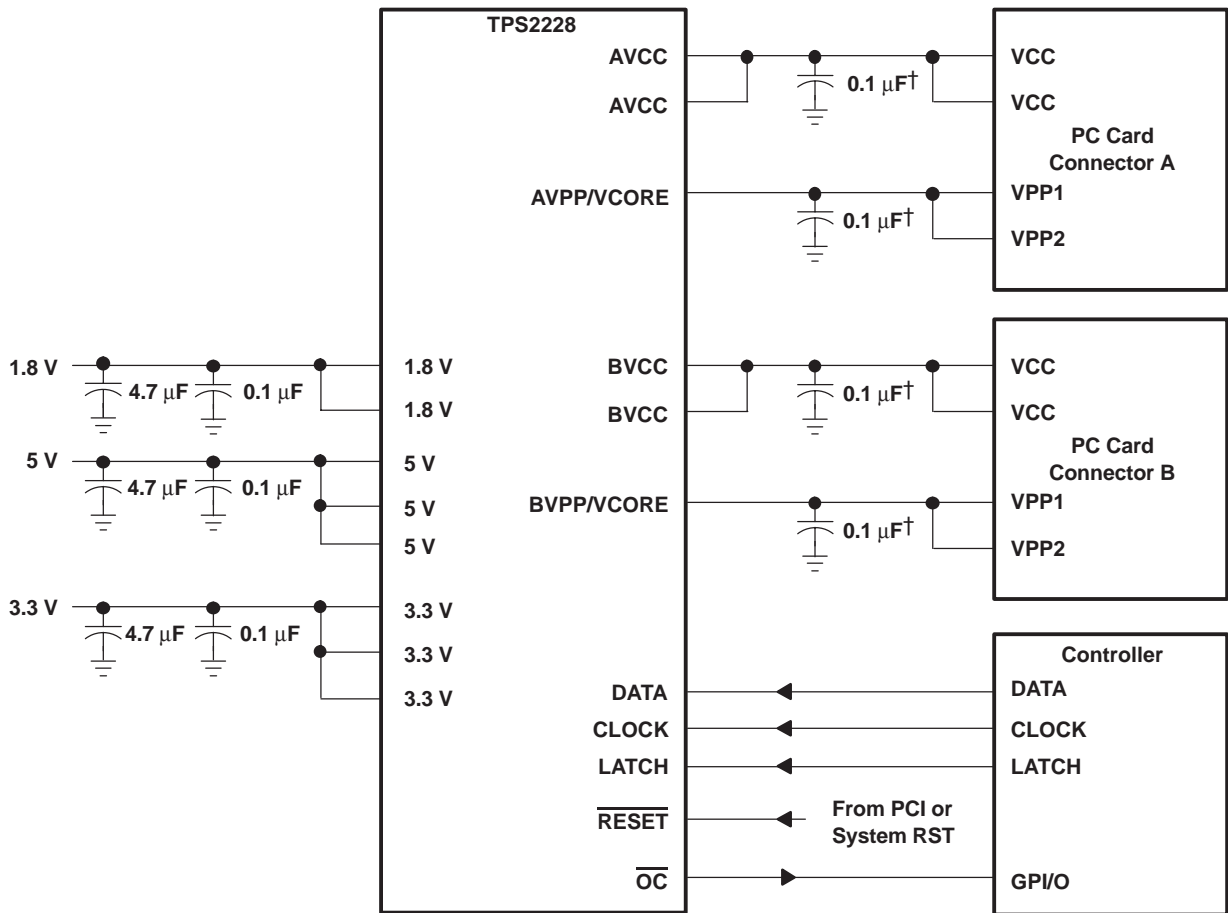
  

xVCC							
D8(SHDN)	AVCC CONTROL SIGNALS		OUTPUT V_AVCC	BVCC CONTROL SIGNALS			OUTPUT V_BVCC
	D3	D2		D8(SHDN)	D6	D7	
1	0	0	0 V	1	0	0	0 V
1	0	1	3.3 V	1	0	1	3.3 V
1	1	0	5 V	1	1	0	5 V
1	1	1	0 V	1	1	1	0 V
0	X	X	Hi-Z	0	X	X	Hi-Z

**Table 2. TPS2221 Control Logic**

TPAS2221 SINGLES					
D0	D1	D2	D3	VCC	VPP/CORE
0	0	0	0	0 V	0 V
0	0	0	1	Hi-Z	Hi-Z
0	0	1	0	Hi-Z	Hi-Z
0	0	1	1	Hi-Z	Hi-Z
0	1	0	0	3.3 V	0 V
0	1	0	1	3.3 V	3.3 V
0	1	1	0	3.3 V	5 V
0	1	1	1	3.3 V	1.8 V
1	0	0	0	5 V	0 V
1	0	0	1	5 V	3.3 V
1	0	1	0	5 V	5 V
1	0	1	1	5 V	1.8 V
1	1	0	0	Hi-Z	Hi-Z
1	1	0	1	3.3 V	Hi-Z
1	1	1	0	5 V	Hi-Z
1	1	1	1	Hi-Z	Hi-Z

NOTE: VCC = VPP/VCORE = Hi-Z indicates the device is in shutdown mode.

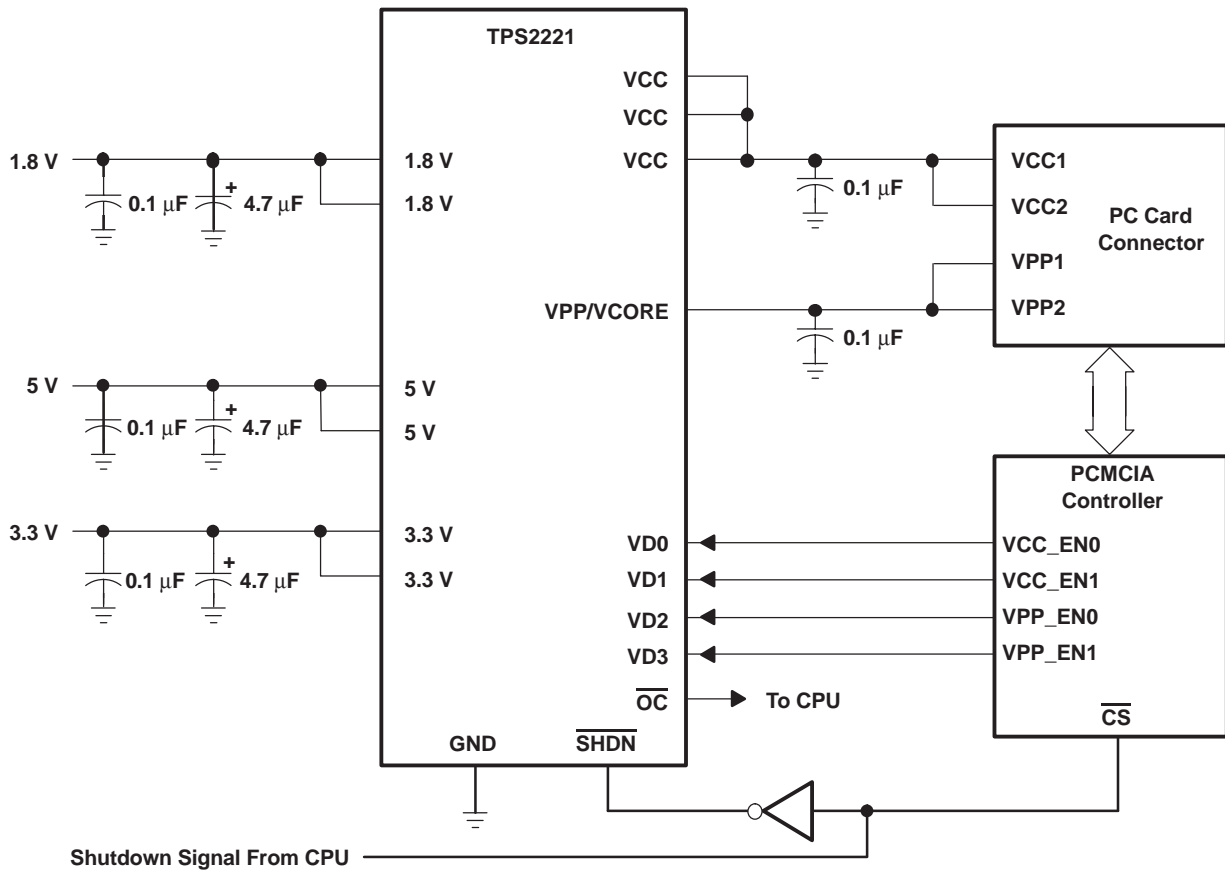


† Maximum recommended output capacitance for xVCC is 150 μF including card capacitance, and for xVPP is 10 μF, without  $\overline{OC}$  glitch when switches are powered on.

**Figure 20. TPS2228 Dual Slot Application**

**TPS2228**  
**TPS2221**

SLVS419A – MAY 2002 REVISED SEPTEMBER 2002



**Figure 21. TPS2221 Single Slot Application**

**PACKAGING INFORMATION**

Orderable Device	Status <sup>(1)</sup>	Package Type	Package Drawing	Pins	Package Qty	Eco Plan <sup>(2)</sup>	Lead/Ball Finish	MSL Peak Temp <sup>(3)</sup>
TPS2221PWP	ACTIVE	HTSSOP	PWP	14	90	Green (RoHS & no Sb/Br)	CU NIPDAU	Level-2-260C-1 YEAR
TPS2221PWPR	ACTIVE	HTSSOP	PWP	14	2000	Green (RoHS & no Sb/Br)	CU NIPDAU	Level-2-260C-1 YEAR
TPS2221PWPRG4	ACTIVE	HTSSOP	PWP	14	2000	Green (RoHS & no Sb/Br)	CU NIPDAU	Level-2-260C-1 YEAR
TPS2228DB	ACTIVE	SSOP	DB	30	50	Green (RoHS & no Sb/Br)	CU NIPDAU	Level-1-260C-UNLIM
TPS2228DBG4	ACTIVE	SSOP	DB	30	50	Green (RoHS & no Sb/Br)	CU NIPDAU	Level-1-260C-UNLIM
TPS2228DBR	ACTIVE	SSOP	DB	30	2000	Green (RoHS & no Sb/Br)	CU NIPDAU	Level-1-260C-UNLIM
TPS2228DBRG4	ACTIVE	SSOP	DB	30	2000	Green (RoHS & no Sb/Br)	CU NIPDAU	Level-1-260C-UNLIM
TPS2228PWP	ACTIVE	HTSSOP	PWP	20	70	Green (RoHS & no Sb/Br)	CU NIPDAU	Level-2-260C-1 YEAR
TPS2228PWPG4	ACTIVE	HTSSOP	PWP	20	70	Green (RoHS & no Sb/Br)	CU NIPDAU	Level-2-260C-1 YEAR
TPS2228PWPR	ACTIVE	HTSSOP	PWP	20	2000	Green (RoHS & no Sb/Br)	CU NIPDAU	Level-2-260C-1 YEAR
TPS2228PWPRG4	ACTIVE	HTSSOP	PWP	20	2000	Green (RoHS & no Sb/Br)	CU NIPDAU	Level-2-260C-1 YEAR

<sup>(1)</sup> The marketing status values are defined as follows:

**ACTIVE:** Product device recommended for new designs.

**LIFEBUY:** TI has announced that the device will be discontinued, and a lifetime-buy period is in effect.

**NRND:** Not recommended for new designs. Device is in production to support existing customers, but TI does not recommend using this part in a new design.

**PREVIEW:** Device has been announced but is not in production. Samples may or may not be available.

**OBSOLETE:** TI has discontinued the production of the device.

<sup>(2)</sup> Eco Plan - The planned eco-friendly classification: Pb-Free (RoHS), Pb-Free (RoHS Exempt), or Green (RoHS & no Sb/Br) - please check <http://www.ti.com/productcontent> for the latest availability information and additional product content details.

**TBD:** The Pb-Free/Green conversion plan has not been defined.

**Pb-Free (RoHS):** TI's terms "Lead-Free" or "Pb-Free" mean semiconductor products that are compatible with the current RoHS requirements for all 6 substances, including the requirement that lead not exceed 0.1% by weight in homogeneous materials. Where designed to be soldered at high temperatures, TI Pb-Free products are suitable for use in specified lead-free processes.

**Pb-Free (RoHS Exempt):** This component has a RoHS exemption for either 1) lead-based flip-chip solder bumps used between the die and package, or 2) lead-based die adhesive used between the die and leadframe. The component is otherwise considered Pb-Free (RoHS compatible) as defined above.

**Green (RoHS & no Sb/Br):** TI defines "Green" to mean Pb-Free (RoHS compatible), and free of Bromine (Br) and Antimony (Sb) based flame retardants (Br or Sb do not exceed 0.1% by weight in homogeneous material)

<sup>(3)</sup> MSL, Peak Temp. -- The Moisture Sensitivity Level rating according to the JEDEC industry standard classifications, and peak solder temperature.

**Important Information and Disclaimer:** The information provided on this page represents TI's knowledge and belief as of the date that it is provided. TI bases its knowledge and belief on information provided by third parties, and makes no representation or warranty as to the accuracy of such information. Efforts are underway to better integrate information from third parties. TI has taken and continues to take reasonable steps to provide representative and accurate information but may not have conducted destructive testing or chemical analysis on incoming materials and chemicals. TI and TI suppliers consider certain information to be proprietary, and thus CAS numbers and other limited information may not be available for release.

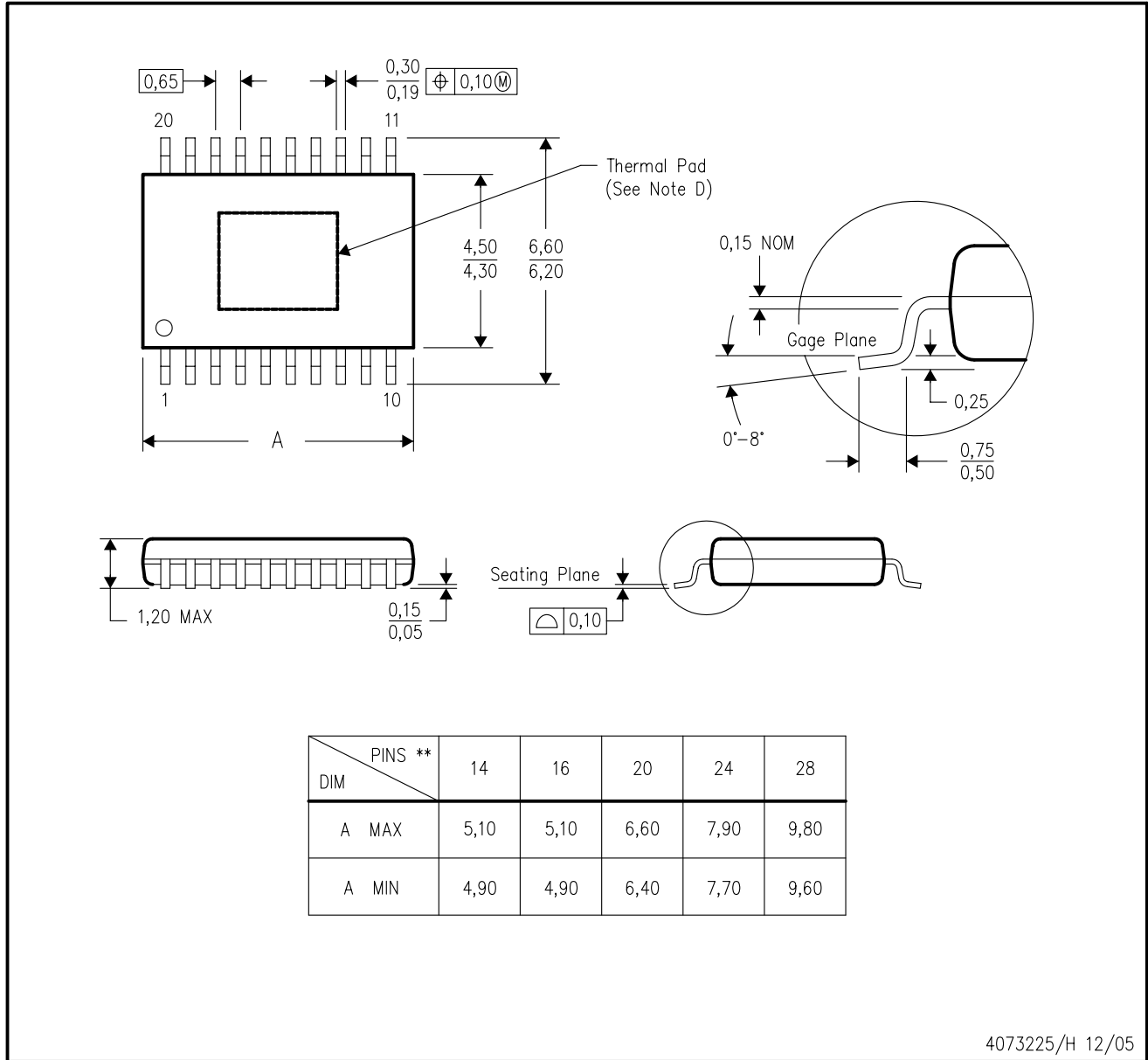
In no event shall TI's liability arising out of such information exceed the total purchase price of the TI part(s) at issue in this document sold by TI

to Customer on an annual basis.

# MECHANICAL DATA

PWP (R-PDSO-G\*\*) 20 PIN SHOWN

PowerPAD™ PLASTIC SMALL-OUTLINE PACKAGE



- NOTES:
- A. All linear dimensions are in millimeters.
  - B. This drawing is subject to change without notice.
  - C. Body dimensions do not include mold flash or protrusions. Mold flash and protrusion shall not exceed 0.15 per side.
  - D. This package is designed to be soldered to a thermal pad on the board. Refer to Technical Brief, PowerPad Thermally Enhanced Package, Texas Instruments Literature No. SLMA002 for information regarding recommended board layout. This document is available at [www.ti.com](http://www.ti.com) <<http://www.ti.com>>.
  - E. Falls within JEDEC MO-153

PowerPAD is a trademark of Texas Instruments.

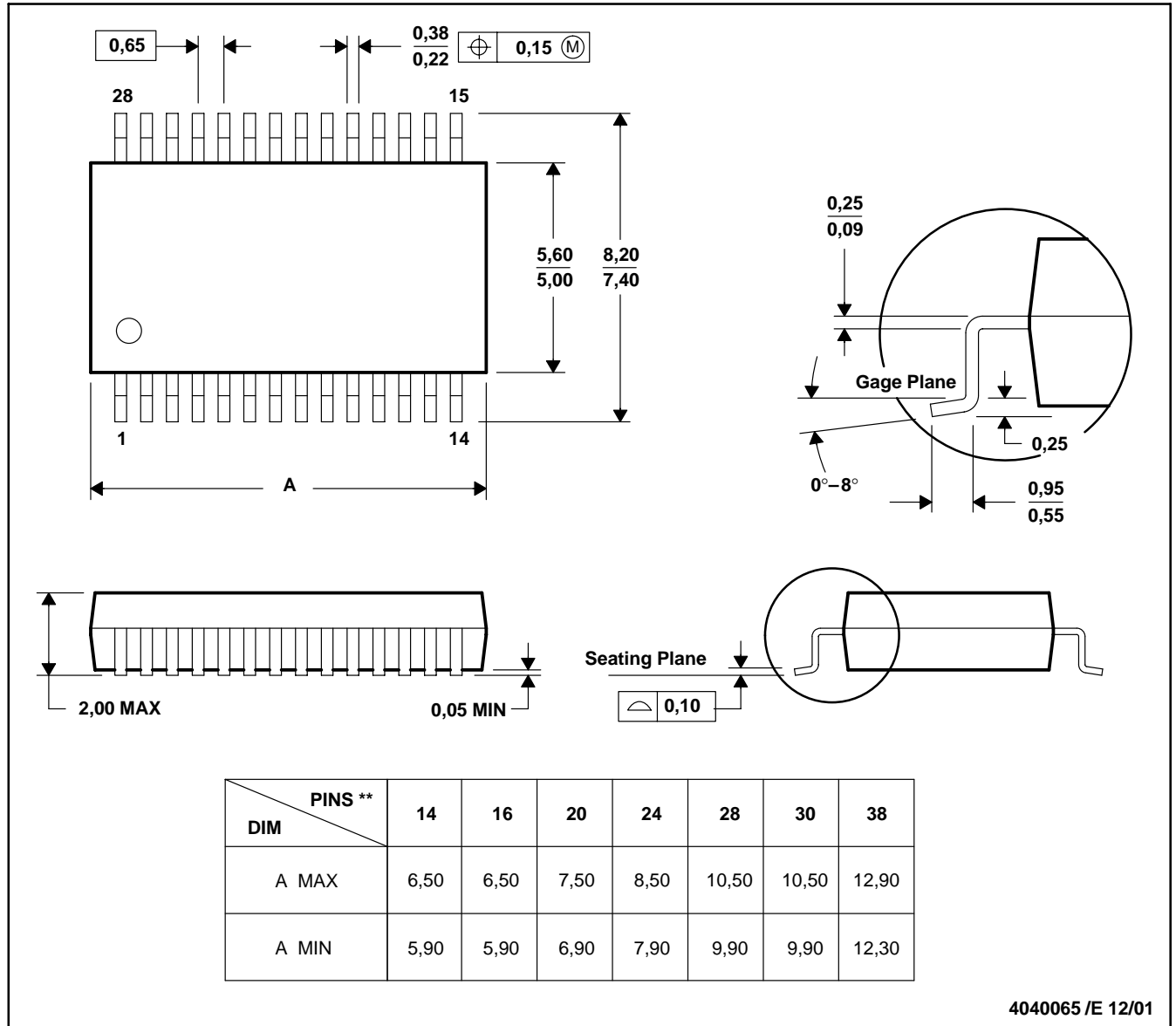
# MECHANICAL DATA

MSS0002E – JANUARY 1995 – REVISED DECEMBER 2001

## DB (R-PDSO-G\*\*)

## PLASTIC SMALL-OUTLINE

28 PINS SHOWN



- NOTES: A. All linear dimensions are in millimeters.  
 B. This drawing is subject to change without notice.  
 C. Body dimensions do not include mold flash or protrusion not to exceed 0,15.  
 D. Falls within JEDEC MO-150



## IMPORTANT NOTICE

Texas Instruments Incorporated and its subsidiaries (TI) reserve the right to make corrections, modifications, enhancements, improvements, and other changes to its products and services at any time and to discontinue any product or service without notice. Customers should obtain the latest relevant information before placing orders and should verify that such information is current and complete. All products are sold subject to TI's terms and conditions of sale supplied at the time of order acknowledgment.

TI warrants performance of its hardware products to the specifications applicable at the time of sale in accordance with TI's standard warranty. Testing and other quality control techniques are used to the extent TI deems necessary to support this warranty. Except where mandated by government requirements, testing of all parameters of each product is not necessarily performed.

TI assumes no liability for applications assistance or customer product design. Customers are responsible for their products and applications using TI components. To minimize the risks associated with customer products and applications, customers should provide adequate design and operating safeguards.

TI does not warrant or represent that any license, either express or implied, is granted under any TI patent right, copyright, mask work right, or other TI intellectual property right relating to any combination, machine, or process in which TI products or services are used. Information published by TI regarding third-party products or services does not constitute a license from TI to use such products or services or a warranty or endorsement thereof. Use of such information may require a license from a third party under the patents or other intellectual property of the third party, or a license from TI under the patents or other intellectual property of TI.

Reproduction of information in TI data books or data sheets is permissible only if reproduction is without alteration and is accompanied by all associated warranties, conditions, limitations, and notices. Reproduction of this information with alteration is an unfair and deceptive business practice. TI is not responsible or liable for such altered documentation.

Resale of TI products or services with statements different from or beyond the parameters stated by TI for that product or service voids all express and any implied warranties for the associated TI product or service and is an unfair and deceptive business practice. TI is not responsible or liable for any such statements.

Following are URLs where you can obtain information on other Texas Instruments products and application solutions:

<b>Products</b>		<b>Applications</b>	
Amplifiers	<a href="http://amplifier.ti.com">amplifier.ti.com</a>	Audio	<a href="http://www.ti.com/audio">www.ti.com/audio</a>
Data Converters	<a href="http://dataconverter.ti.com">dataconverter.ti.com</a>	Automotive	<a href="http://www.ti.com/automotive">www.ti.com/automotive</a>
DSP	<a href="http://dsp.ti.com">dsp.ti.com</a>	Broadband	<a href="http://www.ti.com/broadband">www.ti.com/broadband</a>
Interface	<a href="http://interface.ti.com">interface.ti.com</a>	Digital Control	<a href="http://www.ti.com/digitalcontrol">www.ti.com/digitalcontrol</a>
Logic	<a href="http://logic.ti.com">logic.ti.com</a>	Military	<a href="http://www.ti.com/military">www.ti.com/military</a>
Power Mgmt	<a href="http://power.ti.com">power.ti.com</a>	Optical Networking	<a href="http://www.ti.com/opticalnetwork">www.ti.com/opticalnetwork</a>
Microcontrollers	<a href="http://microcontroller.ti.com">microcontroller.ti.com</a>	Security	<a href="http://www.ti.com/security">www.ti.com/security</a>
		Telephony	<a href="http://www.ti.com/telephony">www.ti.com/telephony</a>
		Video & Imaging	<a href="http://www.ti.com/video">www.ti.com/video</a>
		Wireless	<a href="http://www.ti.com/wireless">www.ti.com/wireless</a>

Mailing Address: Texas Instruments  
Post Office Box 655303 Dallas, Texas 75265