

- $\pm 1\%$ Output Tolerance at 25°C
- $\pm 2\%$ Output Tolerance Over Full Operating Range
- Thermal Shutdown
- Internal Short-Circuit Current Limiting
- Pinout Identical to $\mu A7800$ Series
- Improved Version of $\mu A7800$ Series

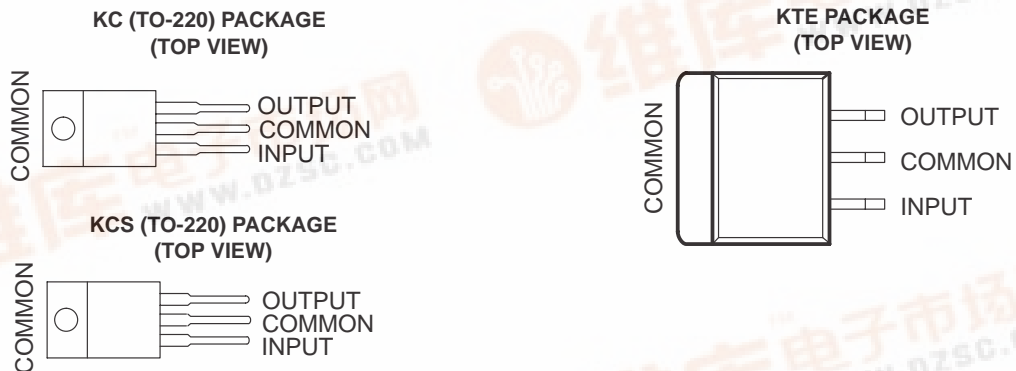

description/ordering information

Each fixed-voltage precision regulator in the TL780 series is capable of supplying 1.5 A of load current. A unique temperature-compensation technique, coupled with an internally trimmed band-gap reference, has resulted in improved accuracy when compared to other three-terminal regulators. Advanced layout techniques provide excellent line, load, and thermal regulation. The internal current-limiting and thermal-shutdown features essentially make the devices immune to overload.

ORDERING INFORMATION

T_J	V_O TYP (V)	PACKAGE†		ORDERABLE PART NUMBER	TOP-SIDE MARKING
0°C to 125°C	5	PowerFLEX™ (KTE)	Reel of 2000	TL780-05CKTER	TL780-05C
		TO-220 (KC)	Tube of 50	TL780-05CKC	TL780-05C
		TO-220, short shoulder (KCS)	Tube of 20	TL780-05KCS	TL780-05
	12	TO-220 (KC)	Tube of 50	TL780-12CKC	TL780-12C
		TO-220, short shoulder (KCS)	Tube of 20	TL780-12KCS	TL780-12
	15	TO-220 (KC)	Tube of 50	TL780-15CKC	TL780-15C
TO-220, short shoulder (KCS)		Tube of 20	TL780-15KCS	TL780-15	

† Package drawings, standard packing quantities, thermal data, symbolization, and PCB design guidelines are available at www.ti.com/sc/package.

Please be aware that an important notice concerning availability, standard warranty, and use in critical applications of Texas Instruments semiconductor products and disclaimers thereto appears at the end of this data sheet.

PowerFLEX is a trademark of Texas Instruments.

PRODUCTION DATA information is current as of publication date. Products conform to specifications per the terms of Texas Instruments standard warranty. Production processing does not necessarily include testing of all parameters.

TL780 SERIES POSITIVE-VOLTAGE REGULATORS

SLVS055L – APRIL 1981 – REVISED APRIL 2005

schematic

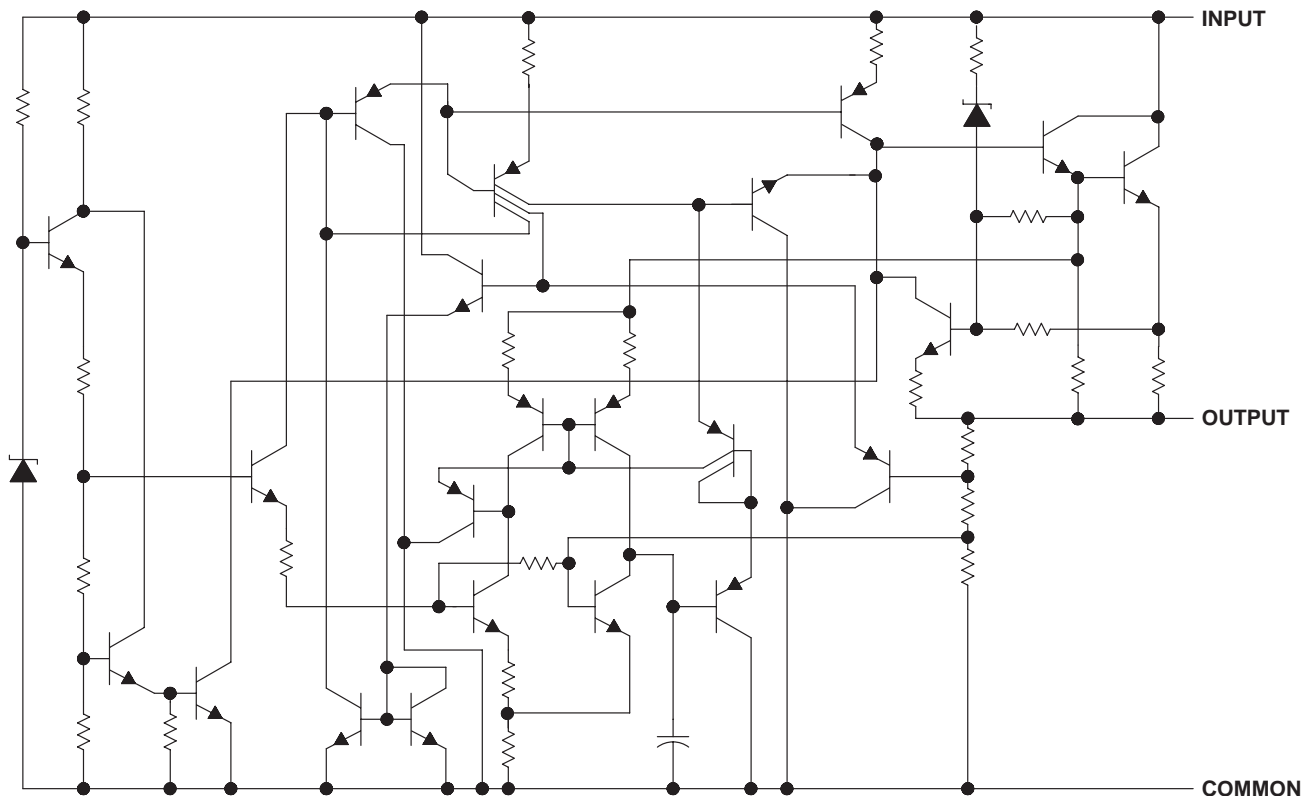

absolute maximum ratings over operating temperature range (unless otherwise noted)†

Input voltage, V_I	35 V
Operating virtual junction temperature, T_J	150°C
Lead temperature 1,6 mm (1/16 inch) from case for 10 seconds	260°C
Storage temperature range, T_{stg}	-65°C to 150°C

† Stresses beyond those listed under “absolute maximum ratings” may cause permanent damage to the device. These are stress ratings only, and functional operation of the device at these or any other conditions beyond those indicated under “recommended operating conditions” is not implied. Exposure to absolute-maximum-rated conditions for extended periods may affect device reliability.

package thermal data (see Note 1)

PACKAGE	BOARD	θ_{JC}	θ_{JA}	$\theta_{JP}‡$
PowerFLEX™ (KTE)	High K, JESD 51-5	3°C/W	23°C/W	
TO-220 (KC/KCS)	High K, JESD 51-5	17°C/W	19°C/W	3°C/W

NOTE 1: Maximum power dissipation is a function of $T_J(\max)$, θ_{JA} , and T_A . The maximum allowable power dissipation at any allowable ambient temperature is $P_D = (T_J(\max) - T_A)/\theta_{JA}$. Operating at the absolute maximum T_J of 150°C can affect reliability. Due to variations in individual device electrical characteristics and thermal resistance, the built-in thermal overload protection may be activated at power levels slightly above or below the rated dissipation.

‡ For packages with exposed thermal pads, such as QFN, PowerPAD, or PowerFLEX, θ_{JP} is defined as the thermal resistance between the die junction and the bottom of the exposed pad.

TL780 SERIES POSITIVE-VOLTAGE REGULATORS

SLVS055L – APRIL 1981 – REVISED APRIL 2005

recommended operating conditions

		MIN	MAX	UNIT	
V_I	Input voltage	TL780-05C	7	25	V
		TL780-12C	14.5	30	
		TL780-15C	17.5	30	
I_O	Output current		1.5	A	
T_J	Operating virtual junction temperature	0	125	°C	

electrical characteristics at specified virtual junction temperature, $V_I = 10\text{ V}$, $I_O = 500\text{ mA}$ (unless otherwise noted)

PARAMETER	TEST CONDITIONS	T_J †	TL780-05C			UNIT
			MIN	TYP	MAX	
Output voltage	$I_O = 5\text{ mA to }1\text{ A}, P \leq 15\text{ W}, V_I = 7\text{ V to }20\text{ V}$	25°C	4.95	5	5.05	V
		0°C to 125°C	4.9		5.1	
Input voltage regulation	$V_I = 7\text{ V to }25\text{ V}$	25°C		0.5	5	mV
	$V_I = 8\text{ V to }12\text{ V}$			0.5	5	
Ripple rejection	$V_I = 8\text{ V to }18\text{ V}, f = 120\text{ Hz}$	0°C to 125°C	70	85		dB
Output voltage regulation	$I_O = 5\text{ mA to }1.5\text{ A}$	25°C		4	25	mV
	$I_O = 250\text{ mA to }750\text{ mA}$			1.5	15	
Output resistance	$f = 1\text{ kHz}$	0°C to 125°C	0.0035			Ω
Temperature coefficient of output voltage	$I_O = 5\text{ mA}$	0°C to 125°C	0.25			mV/°C
Output noise voltage	$f = 10\text{ Hz to }100\text{ kHz}$	25°C	75			μV
Dropout voltage	$I_O = 1\text{ A}$	25°C	2			V
Input bias current		25°C	5 8			mA
Input bias-current change	$V_I = 7\text{ V to }25\text{ V}$	0°C to 125°C	0.7 1.3		mA	
	$I_O = 5\text{ mA to }1\text{ A}$		0.003 0.5			
Short-circuit output current		25°C	750			mA
Peak output current		25°C	2.2			A

† Pulse-testing techniques maintain the junction temperature as close to the ambient temperature as possible. Thermal effects must be taken into account separately. All characteristics are measured with a 0.33- μF capacitor across the input and a 0.22- μF capacitor across the output.

TL780 SERIES POSITIVE-VOLTAGE REGULATORS

SLVS055L – APRIL 1981 – REVISED APRIL 2005

electrical characteristics at specified virtual junction temperature, $V_I = 19\text{ V}$, $I_O = 500\text{ mA}$ (unless otherwise noted)

PARAMETER	TEST CONDITIONS	$T_{J\ddagger}$	TL780-12C			UNIT
			MIN	TYP	MAX	
Output voltage	$I_O = 5\text{ mA to }1\text{ A}, P \leq 15\text{ W}, V_I = 14.5\text{ V to }27\text{ V}$	25°C	11.88	12	12.12	V
		0°C to 125°C	11.76		12.24	
Input voltage regulation	$V_I = 14.5\text{ V to }30\text{ V}$	25°C	1.2		12	mV
	$V_I = 16\text{ V to }22\text{ V}$		1.2		12	
Ripple rejection	$V_I = 15\text{ V to }25\text{ V}, f = 120\text{ Hz}$	0°C to 125°C	65	80		dB
Output voltage regulation	$I_O = 5\text{ mA to }1.5\text{ A}$	25°C	6.5		60	mV
	$I_O = 250\text{ mA to }750\text{ mA}$		2.5		36	
Output resistance	$f = 1\text{ kHz}$	0°C to 125°C	0.0035			Ω
Temperature coefficient of output voltage	$I_O = 5\text{ mA}$	0°C to 125°C	0.6			mV/°C
Output noise voltage	$f = 10\text{ Hz to }100\text{ kHz}$	25°C	180			μV
Dropout voltage	$I_O = 1\text{ A}$	25°C	2			V
Input bias current		25°C	5.5		8	mA
Input bias-current change	$V_I = 14.5\text{ V to }30\text{ V}$	0°C to 125°C	0.4		1.3	mA
	$I_O = 5\text{ mA to }1\text{ A}$		0.03		0.5	
Short-circuit output current		25°C	350			mA
Peak output current		25°C	2.2			A

† Pulse-testing techniques maintain the junction temperature as close to the ambient temperature as possible. Thermal effects must be taken into account separately. All characteristics are measured with a 0.33- μF capacitor across the input and a 0.22- μF capacitor across the output.

electrical characteristics at specified virtual junction temperature, $V_I = 23\text{ V}$, $I_O = 500\text{ mA}$ (unless otherwise noted)

PARAMETER	TEST CONDITIONS	$T_{J\ddagger}$	TL780-15C			UNIT
			MIN	TYP	MAX	
Output voltage	$I_O = 5\text{ mA to }1\text{ A}, P \leq 15\text{ W}, V_I = 17.5\text{ V to }30\text{ V}$	25°C	14.85	15	15.15	V
		0°C to 125°C	14.7		15.3	
Input voltage regulation	$V_I = 17.5\text{ V to }30\text{ V}$	25°C	1.5		15	mV
	$V_I = 20\text{ V to }26\text{ V}$		1.5		15	
Ripple rejection	$V_I = 18.5\text{ V to }28.5\text{ V}, f = 120\text{ Hz}$	0°C to 125°C	60	75		dB
Output voltage regulation	$I_O = 5\text{ mA to }1.5\text{ A}$	25°C	7		75	mV
	$I_O = 250\text{ mA to }750\text{ mA}$		2.5		45	
Output resistance	$f = 1\text{ kHz}$	0°C to 125°C	0.0035			Ω
Temperature coefficient of output voltage	$I_O = 5\text{ mA}$	0°C to 125°C	0.62			mV/°C
Output noise voltage	$f = 10\text{ Hz to }100\text{ kHz}$	25°C	225			μV
Dropout voltage	$I_O = 1\text{ A}$	25°C	2			V
Input bias current		25°C	5.5		8	mA
Input bias-current change	$V_I = 17.5\text{ V to }30\text{ V}$	0°C to 125°C	0.4		1.3	mA
	$I_O = 5\text{ mA to }1\text{ A}$		0.02		0.5	
Short-circuit output current		25°C	230			mA
Peak output current		25°C	2.2			A

† Pulse-testing techniques maintain the junction temperature as close to the ambient temperature as possible. Thermal effects must be taken into account separately. All characteristics are measured with a 0.33- μF capacitor across the input and a 0.22- μF capacitor across the output.

TL780 SERIES POSITIVE-VOLTAGE REGULATORS

SLVS055L – APRIL 1981 – REVISED APRIL 2005

PARAMETER MEASUREMENT INFORMATION

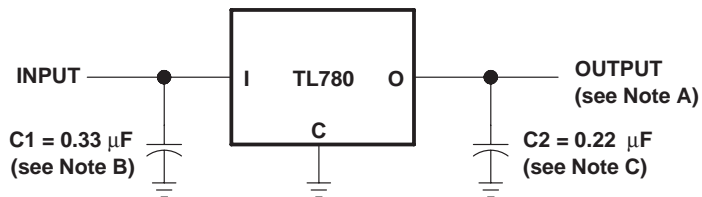

- NOTES: A. Permanent damage can occur when OUTPUT is pulled below ground.
B. C1 is required when the regulator is far from the power-supply filter.
C. C2 is not required for stability; however, transient response is improved.

Figure 1. Test Circuit

TL780 SERIES POSITIVE-VOLTAGE REGULATORS

SLVS055L – APRIL 1981 – REVISED APRIL 2005

APPLICATION INFORMATION

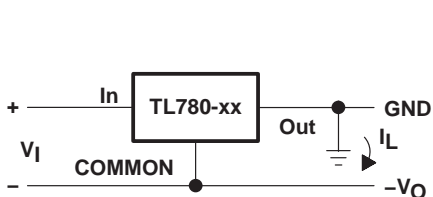
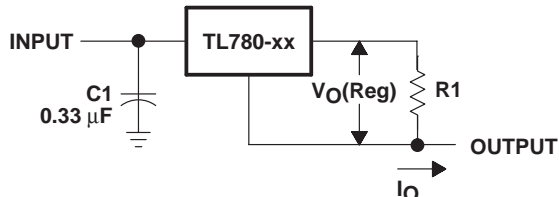

Figure 2. Positive Regulator in Negative Configuration (V_I Must Float)



$$I_O = (V_O/R1) + I_O \text{ Bias Current}$$

Figure 3. Current Regulator

operation with a load common to a voltage of opposite polarity

In many cases, a regulator powers a load that is not connected to ground, but instead, is connected to a voltage source of opposite polarity (e.g., operational amplifiers, level-shifting circuits, etc.). In these cases, a clamp diode should be connected to the regulator output as shown in Figure 4. This protects the regulator from output polarity reversals during startup and short-circuit operation.

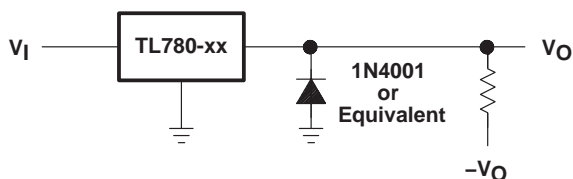

Figure 4. Output Polarity-Reversal-Protection Circuit

reverse-bias protection

Occasionally, the input voltage to the regulator can collapse faster than the output voltage. This, for example, could occur when the input supply is crowbarred during an output overvoltage condition. If the output voltage is greater than approximately 7 V, the emitter-base junction of the series pass element (internal or external) could break down and be damaged. To prevent this, a diode shunt can be employed, as shown in Figure 5.

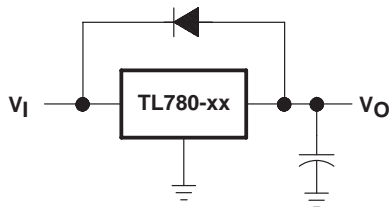

Figure 5. Reverse-Bias-Protection Circuit

PACKAGING INFORMATION

Orderable Device	Status ⁽¹⁾	Package Type	Package Drawing	Pins	Package Qty	Eco Plan ⁽²⁾	Lead/Ball Finish	MSL Peak Temp ⁽³⁾
TL780-05CKC	NRND	TO-220	KC	3	50	TBD	CU SNPB	N / A for Pkg Type
TL780-05CKTER	NRND	PFM	KTE	3	2000	TBD	CU SNPB	Level-1-220C-UNLIM
TL780-05KCS	ACTIVE	TO-220	KCS	3	50	TBD	CU SNPB	N / A for Pkg Type
TL780-12CKC	NRND	TO-220	KC	3	50	TBD	CU SNPB	N / A for Pkg Type
TL780-12CKCE3	NRND	TO-220	KC	3	50	Pb-Free (RoHS)	CU SN	N / A for Pkg Type
TL780-12CKTER	OBSOLETE	PFM	KTE	3		TBD	Call TI	Call TI
TL780-12KCS	ACTIVE	TO-220	KCS	3	50	TBD	CU SNPB	N / A for Pkg Type
TL780-15CKC	NRND	TO-220	KC	3	50	TBD	CU SNPB	N / A for Pkg Type
TL780-15CKTER	OBSOLETE	PFM	KTE	3		TBD	Call TI	Call TI
TL780-15KCS	ACTIVE	TO-220	KCS	3	50	TBD	CU SNPB	N / A for Pkg Type

⁽¹⁾ The marketing status values are defined as follows:

ACTIVE: Product device recommended for new designs.

LIFEBUY: TI has announced that the device will be discontinued, and a lifetime-buy period is in effect.

NRND: Not recommended for new designs. Device is in production to support existing customers, but TI does not recommend using this part in a new design.

PREVIEW: Device has been announced but is not in production. Samples may or may not be available.

OBSOLETE: TI has discontinued the production of the device.

⁽²⁾ Eco Plan - The planned eco-friendly classification: Pb-Free (RoHS), Pb-Free (RoHS Exempt), or Green (RoHS & no Sb/Br) - please check <http://www.ti.com/productcontent> for the latest availability information and additional product content details.

TBD: The Pb-Free/Green conversion plan has not been defined.

Pb-Free (RoHS): TI's terms "Lead-Free" or "Pb-Free" mean semiconductor products that are compatible with the current RoHS requirements for all 6 substances, including the requirement that lead not exceed 0.1% by weight in homogeneous materials. Where designed to be soldered at high temperatures, TI Pb-Free products are suitable for use in specified lead-free processes.

Pb-Free (RoHS Exempt): This component has a RoHS exemption for either 1) lead-based flip-chip solder bumps used between the die and package, or 2) lead-based die adhesive used between the die and leadframe. The component is otherwise considered Pb-Free (RoHS compatible) as defined above.

Green (RoHS & no Sb/Br): TI defines "Green" to mean Pb-Free (RoHS compatible), and free of Bromine (Br) and Antimony (Sb) based flame retardants (Br or Sb do not exceed 0.1% by weight in homogeneous material)

⁽³⁾ MSL, Peak Temp. -- The Moisture Sensitivity Level rating according to the JEDEC industry standard classifications, and peak solder temperature.

Important Information and Disclaimer: The information provided on this page represents TI's knowledge and belief as of the date that it is provided. TI bases its knowledge and belief on information provided by third parties, and makes no representation or warranty as to the accuracy of such information. Efforts are underway to better integrate information from third parties. TI has taken and continues to take reasonable steps to provide representative and accurate information but may not have conducted destructive testing or chemical analysis on incoming materials and chemicals. TI and TI suppliers consider certain information to be proprietary, and thus CAS numbers and other limited information may not be available for release.

In no event shall TI's liability arising out of such information exceed the total purchase price of the TI part(s) at issue in this document sold by TI to Customer on an annual basis.

MECHANICAL DATA

MPFM001E – OCTOBER 1994 – REVISED JANUARY 2001

KTE (R-PSFM-G3)

PowerFLEX™ PLASTIC FLANGE-MOUNT

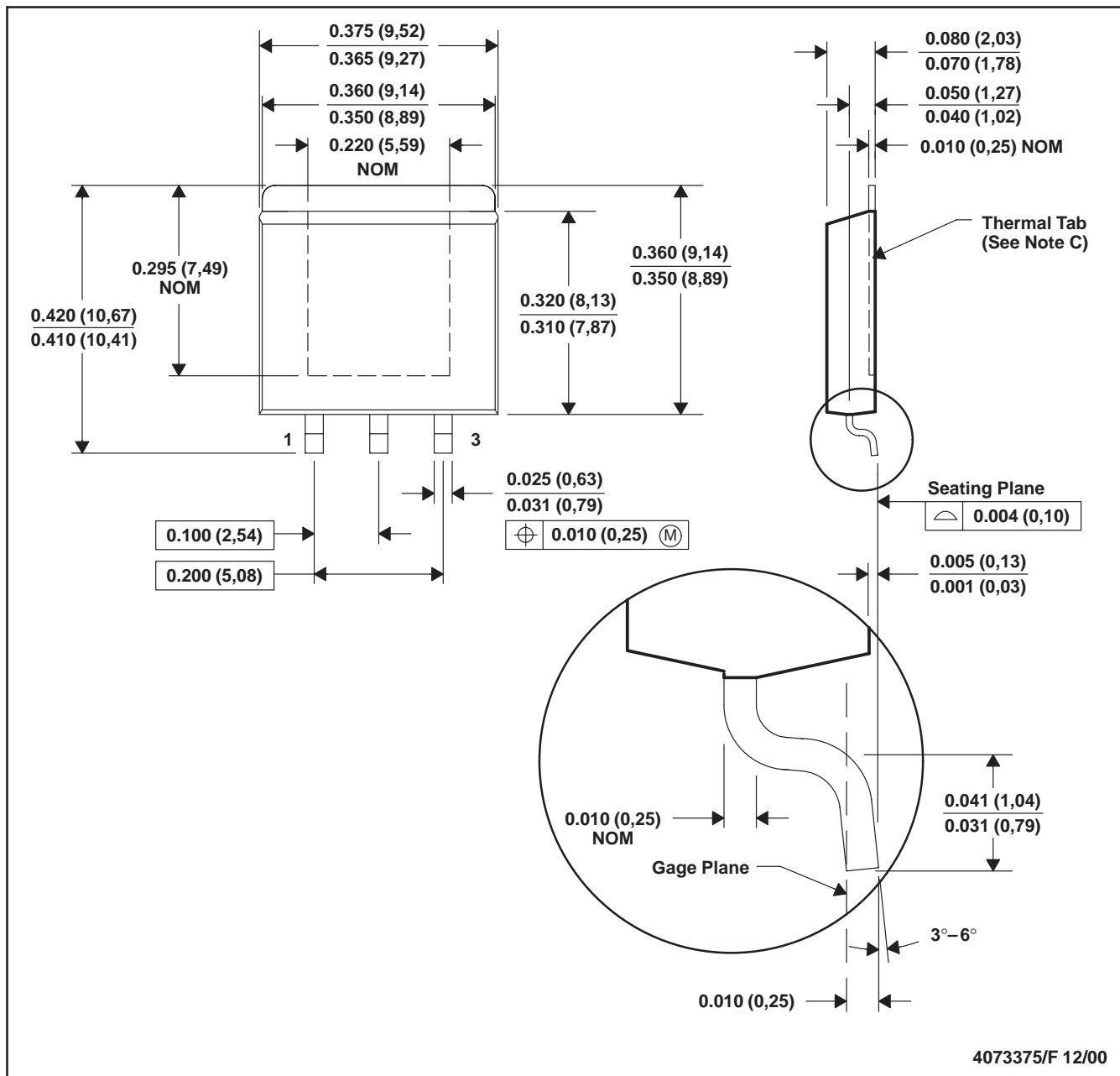

- NOTES:
- A. All linear dimensions are in inches (millimeters).
 - B. This drawing is subject to change without notice.
 - C. The center lead is in electrical contact with the thermal tab.
 - D. Dimensions do not include mold protrusions, not to exceed 0.006 (0,15).
 - E. Falls within JEDEC MO-169

PowerFLEX is a trademark of Texas Instruments.

MECHANICAL DATA

KCS (R-PSFM-T3)

PLASTIC FLANGE-MOUNT PACKAGE

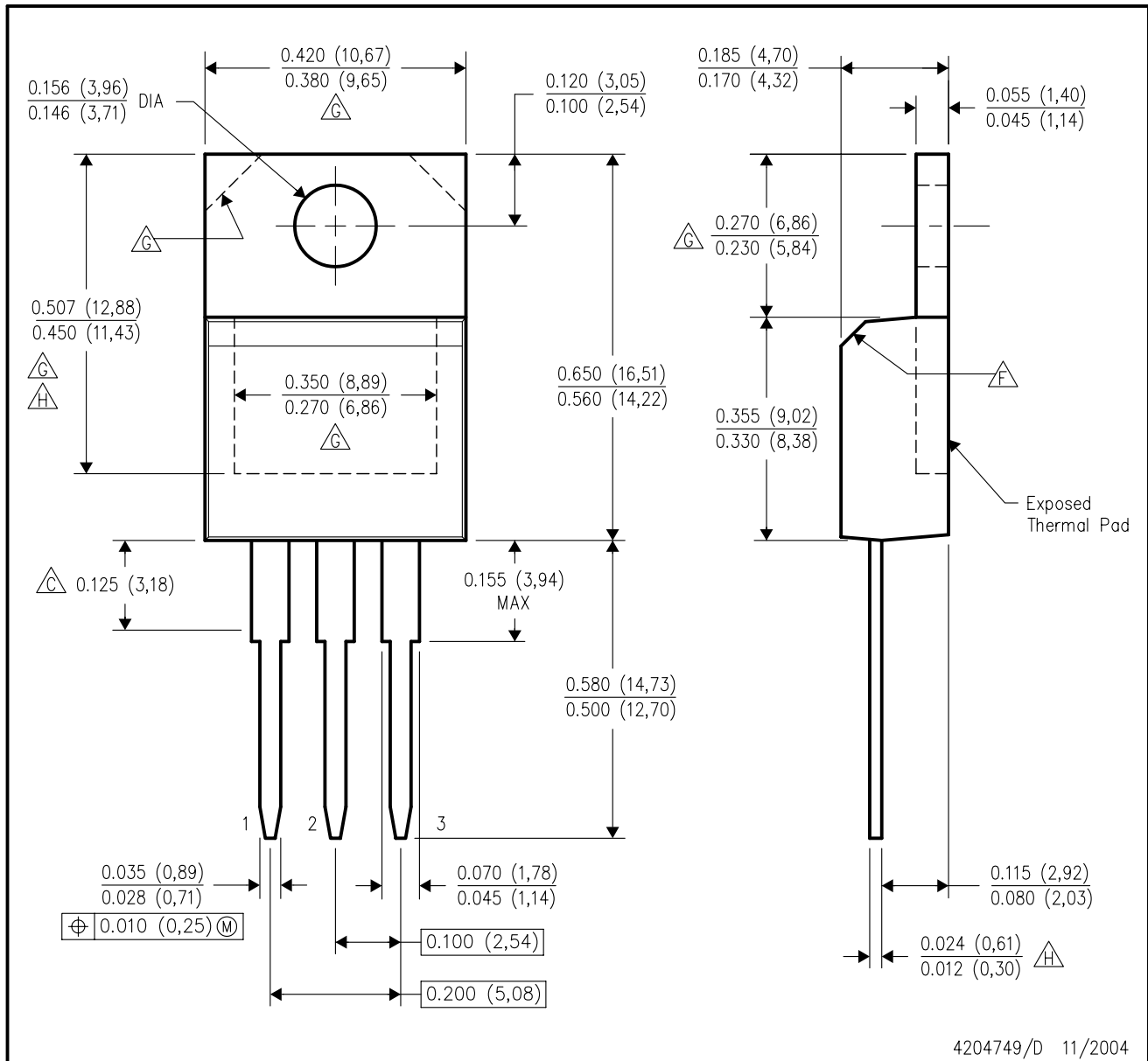

- NOTES:
- All linear dimensions are in inches (millimeters).
 - This drawing is subject to change without notice.
 - Lead dimensions are not controlled within this area.
 - All lead dimensions apply before solder dip.
 - The center lead is in electrical contact with the mounting tab.
 - The chamfer is optional.
 - Thermal pad contour optional within these dimensions.
 - Falls within JEDEC TO-220 variation AB, except minimum lead thickness and minimum exposed pad length.

MECHANICAL DATA

KC (R-PSFM-T3)

PLASTIC FLANGE-MOUNT PACKAGE

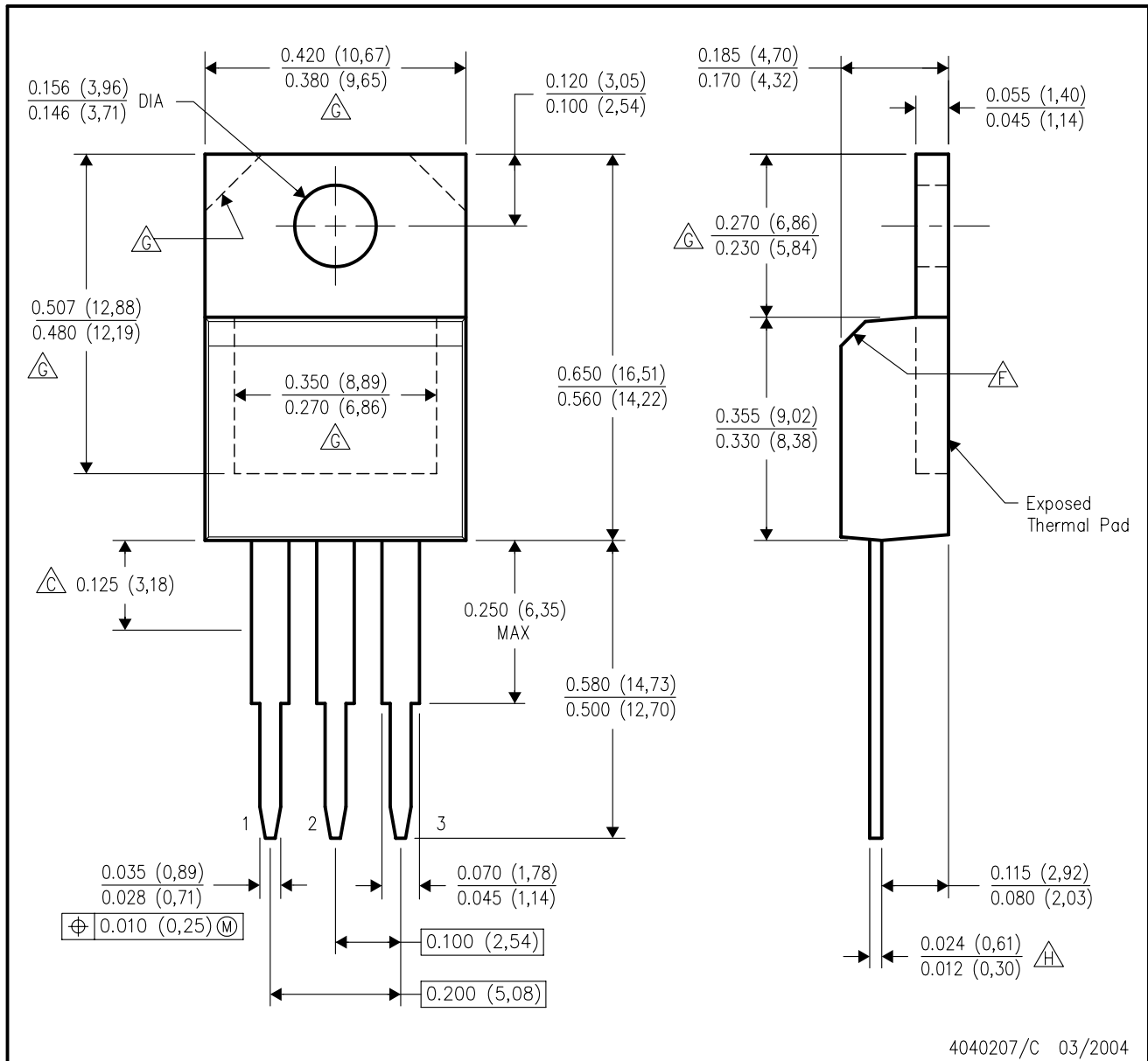

- NOTES:
- All linear dimensions are in inches (millimeters).
 - This drawing is subject to change without notice.
 - Lead dimensions are not controlled within this area.
 - All lead dimensions apply before solder dip.
 - The center lead is in electrical contact with the mounting tab.
 - The chamfer is optional.
 - Thermal pad contour optional within these dimensions.
 - Falls within JEDEC TO-220 variation AB, except minimum lead thickness.

IMPORTANT NOTICE

Texas Instruments Incorporated and its subsidiaries (TI) reserve the right to make corrections, modifications, enhancements, improvements, and other changes to its products and services at any time and to discontinue any product or service without notice. Customers should obtain the latest relevant information before placing orders and should verify that such information is current and complete. All products are sold subject to TI's terms and conditions of sale supplied at the time of order acknowledgment.

TI warrants performance of its hardware products to the specifications applicable at the time of sale in accordance with TI's standard warranty. Testing and other quality control techniques are used to the extent TI deems necessary to support this warranty. Except where mandated by government requirements, testing of all parameters of each product is not necessarily performed.

TI assumes no liability for applications assistance or customer product design. Customers are responsible for their products and applications using TI components. To minimize the risks associated with customer products and applications, customers should provide adequate design and operating safeguards.

TI does not warrant or represent that any license, either express or implied, is granted under any TI patent right, copyright, mask work right, or other TI intellectual property right relating to any combination, machine, or process in which TI products or services are used. Information published by TI regarding third-party products or services does not constitute a license from TI to use such products or services or a warranty or endorsement thereof. Use of such information may require a license from a third party under the patents or other intellectual property of the third party, or a license from TI under the patents or other intellectual property of TI.

Reproduction of information in TI data books or data sheets is permissible only if reproduction is without alteration and is accompanied by all associated warranties, conditions, limitations, and notices. Reproduction of this information with alteration is an unfair and deceptive business practice. TI is not responsible or liable for such altered documentation.

Resale of TI products or services with statements different from or beyond the parameters stated by TI for that product or service voids all express and any implied warranties for the associated TI product or service and is an unfair and deceptive business practice. TI is not responsible or liable for any such statements.

Following are URLs where you can obtain information on other Texas Instruments products and application solutions:

Products		Applications	
Amplifiers	amplifier.ti.com	Audio	www.ti.com/audio
Data Converters	dataconverter.ti.com	Automotive	www.ti.com/automotive
DSP	dsp.ti.com	Broadband	www.ti.com/broadband
Interface	interface.ti.com	Digital Control	www.ti.com/digitalcontrol
Logic	logic.ti.com	Military	www.ti.com/military
Power Mgmt	power.ti.com	Optical Networking	www.ti.com/opticalnetwork
Microcontrollers	microcontroller.ti.com	Security	www.ti.com/security
		Telephony	www.ti.com/telephony
		Video & Imaging	www.ti.com/video
		Wireless	www.ti.com/wireless

Mailing Address: Texas Instruments
Post Office Box 655303 Dallas, Texas 75265