

Multi-Phase PWM Controller for CPU Core Power Supply

General Description

The RT9246 is a multi-phase buck DC/DC controller integrated with all control functions for GHz CPU VRM. The RT9246 controls 2 or 3 buck switching stages operating in interleaved phase set automatically. The multi-phase architecture provides high output current while maintaining low power dissipation on power devices and low stress on input and output capacitors. The high equivalent operating frequency also reduces the component dimension and the output voltage ripple in load transient.

RT9246 controls both voltage and current loops to achieve good regulation, response & power stage thermal balance. Precise current loop using $R_{DS(ON)}$ as sense component builds precise load line for strict VRM DC & transient specification and also ensures thermal balance of different power stages. The settings of current sense, droop tuning, V_{CORE} initial offset and over current protection are independent to compensation circuit of voltage loop. The feature greatly facilitates the flexibility of CPU power supply design and tuning.

The DAC output of RT9246 supports K8 CPU by 5-bit VID input, precise initial value & smooth V_{CORE} transient at VID jump. The IC monitors the V_{CORE} voltage for PGOOD and over-voltage protection. Soft-start, over-current protection and programmable under-voltage lockout are also provided to assure the safety of microprocessor and power system.

Ordering Information

RT9246 □ □

Package Type
C : TSSOP-28

Operating Temperature Range
C : Commercial Standard
P : Pb Free with Commercial Standard

Note :

RichTek Pb-free products are :

-RoHS compliant and compatible with the current requirements of IPC/JEDEC J-STD-020.

-Suitable for use in SnPb or Pb-free soldering processes.

-100% matte tin (Sn) plating.

Features

- Multi-Phase Power Conversion with Automatic Phase Selection
- K8 DAC Output with Active Droop Compensation for Fast Load Transient
- Smooth V_{CORE} Transition at VID Jump
- Power Stage Thermal Balance by $R_{DS(ON)}$ Current Sense
- Hiccup Mode Over-Current Protection
- Programmable Switching Frequency (50kHz to 400kHz per Phase), Under-Voltage Lockout and Soft-Start
- High Ripple Frequency Times Channel Number
- RoHS Compliant and 100% Lead (Pb)-Free

Applications

- AMD® Athlon™ 64 and Opteron™ Processors Voltage Regulator
- Low Output Voltage, High Current DC-DC Converters
- Voltage Regulator Modules

Pin Configurations

(TOP VIEW)

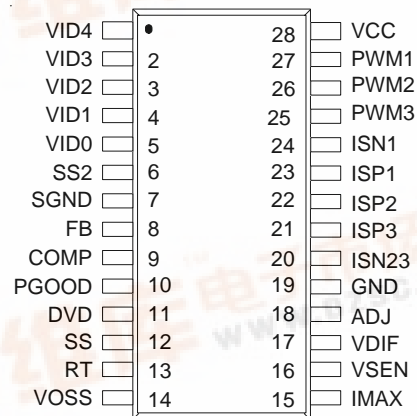

TSSOP-28

Typical Application Circuit

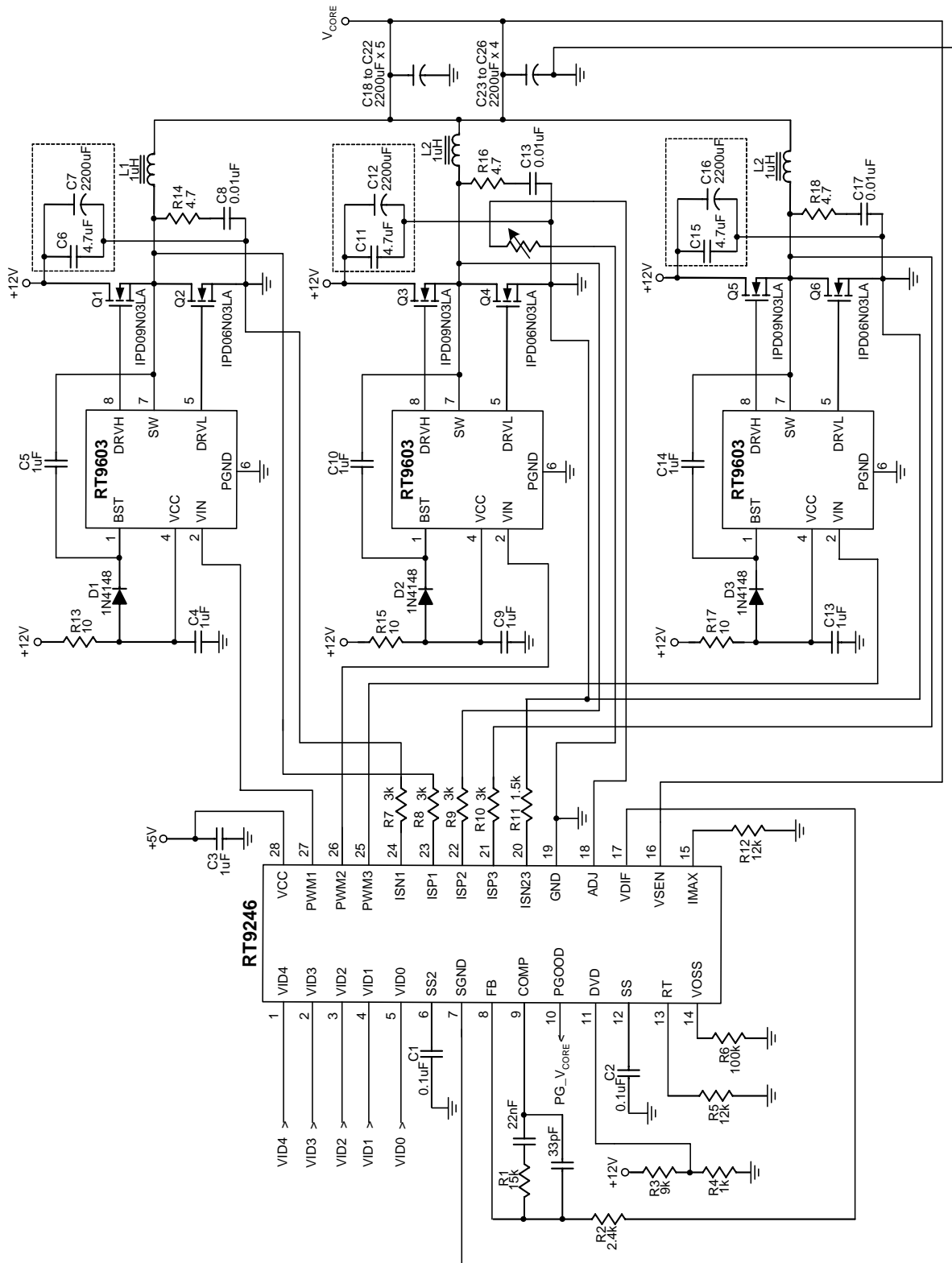

Functional Pin Description

VID4 (Pin 1), VID3 (Pin 2), VID2 (Pin 3), VID1 (Pin 4), VID0 (Pin 5)

DAC voltage identification inputs for K8. These pins are internally pulled to 2.4V if left open.

SS2 (Pin 6)

DAC O/P ramping speed control for K8. Connect this pin to GND with a capacitor to set the rising/falling time at VID jump.

SGND (Pin 7)

V_{CORE} differential sense negative input.

FB (Pin 8)

Inverting input of the internal error amplifier.

COMP (Pin 9)

Output of the error amplifier and input of the PWM comparator.

PGOOD (Pin 10)

Power good open-drain output.

DVD (Pin 11)

Programmable power UVLO detection or converter enable input.

SS (Pin 12)

Connect this SS pin to GND with a capacitor to set the soft-start time interval.

RT (Pin 13)

Switching frequency setting. Connect this pin to GND with a resistor to set the frequency.

VOSS (Pin 14)

V_{CORE} initial value offset. Connect this pin to GND with a resistor to set the offset value.

IMAX (Pin 15)

Over-Current protection set.

VSEN (Pin 16)

V_{CORE} differential sense positive input.

VDIF (Pin 17)

V_{CORE} differential sense output.

ADJ (Pin 18)

Current sense output for active droop adjust. Connect a resistor from this pin to GND to set the load droop.

GND (Pin 19)

IC ground.

ISN23 (Pin 20)

R_{DS(ON)} current sense inputs from converter 2nd & 3rd phase channel sense components' GND node.

ISP1 (Pin 23), ISP2 (Pin 22), ISP3 (Pin 21)

R_{DS(ON)} current sense inputs for individual converter channels. Tie this pin to the component's sense node.

ISN1 (Pin 24)

R_{DS(ON)} current sense inputs from converter 1st channel sense component's GND node.

PWM1 (Pin 27), PWM2 (Pin 26), PWM3 (Pin 25)

PWM outputs for each driven channel. Connect these pins to the PWM input of the MOSFET driver. For systems which use 2 channels, connect PWM3 high.

VCC (Pin 28)

IC power supply. Connect this pin to a 5V supply.

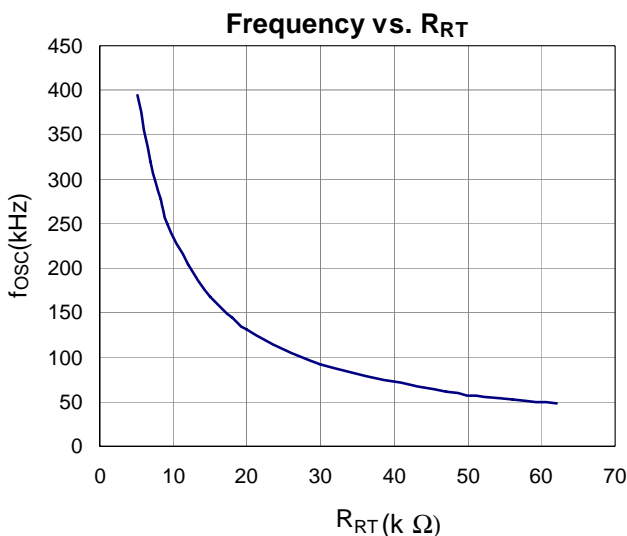

Function Block Diagram

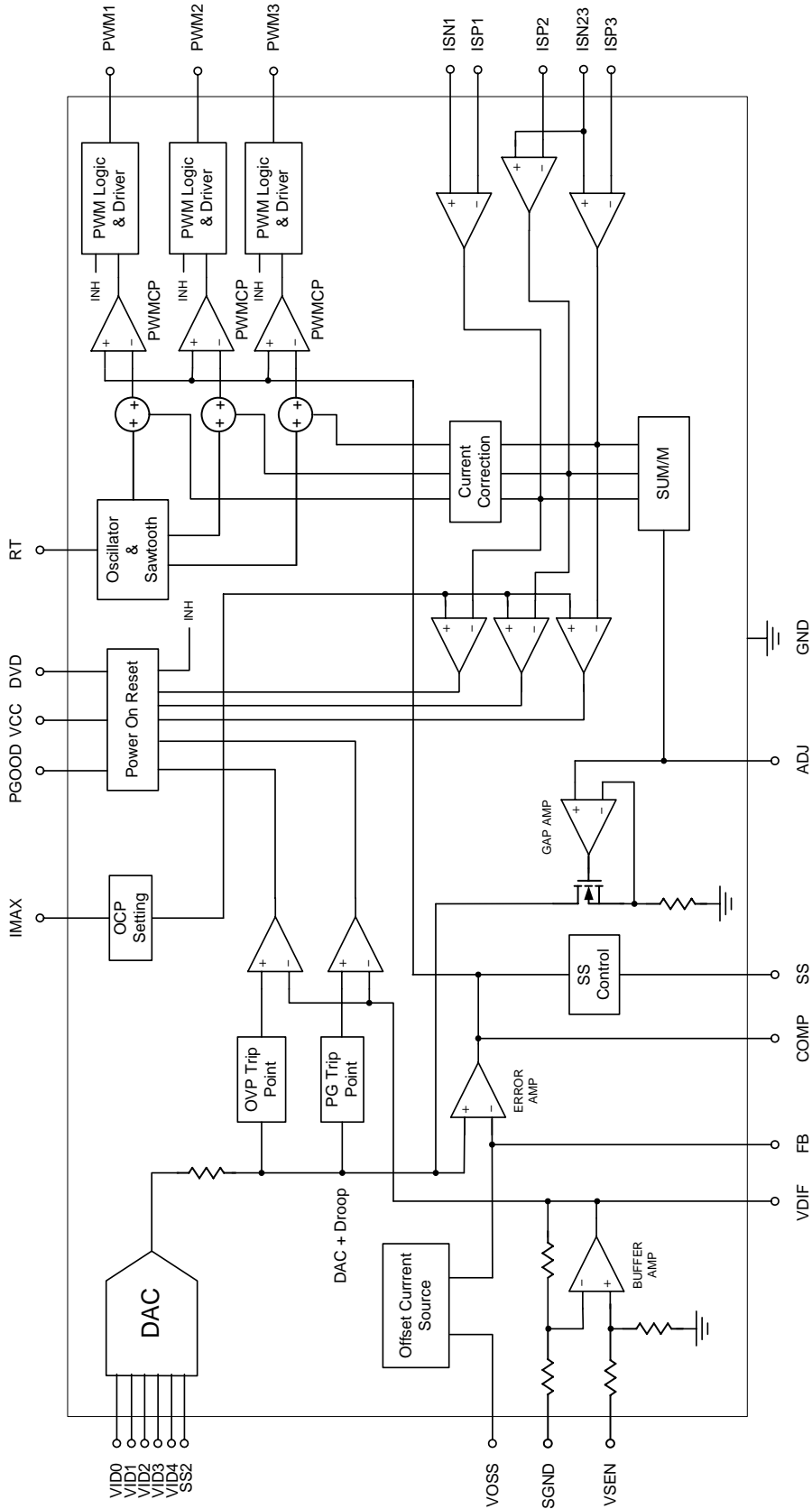

Table 1. Output Voltage Program

VID4	VID3	VID2	VID1	VID0	Nominal Output Voltage DACOUT
0	0	0	0	0	1.550
0	0	0	0	1	1.525
0	0	0	1	0	1.500
0	0	0	1	1	1.475
0	0	1	0	0	1.450
0	0	1	0	1	1.425
0	0	1	1	0	1.400
0	0	1	1	1	1.375
0	1	0	0	0	1.350
0	1	0	0	1	1.325
0	1	0	1	0	1.200
0	1	0	1	1	1.275
0	1	1	0	0	1.250
0	1	1	0	1	1.225
0	1	1	1	0	1.200
0	1	1	1	1	1.175
1	0	0	0	0	1.150
1	0	0	0	1	1.125
1	0	0	1	0	1.100
1	0	0	1	1	1.075
1	0	1	0	0	1.050
1	0	1	0	1	1.025
1	0	1	1	0	1.000
1	0	1	1	1	0.975
1	1	0	0	0	0.950
1	1	0	0	1	0.925
1	1	0	1	0	0.900
1	1	0	1	1	0.875
1	1	1	0	0	0.850
1	1	1	0	1	0.825
1	1	1	1	0	0.800
1	1	1	1	1	Shutdown

Note: (1) 0 : Connected to GND
 (2) 1 : Open

Absolute Maximum Ratings (Note 1)

- Supply Voltage, V_{CC} ----- 7V
- Input, Output or I/O Voltage ----- GND-0.3V to $V_{CC}+0.3V$
- Power Dissipation, P_D @ $T_A = 25^\circ C$
 TSSOP-28 ----- 1W
- Package Thermal Resistance (Note 4)
 TSSOP-28, θ_{JA} ----- $100^\circ C/W$
- Junction Temperature ----- $150^\circ C$
- Lead Temperature (Soldering, 10 sec.) ----- $260^\circ C$
- Storage Temperature Range ----- $-65^\circ C$ to $150^\circ C$
- ESD Susceptibility (Note 2)
 HBM (Human Body Mode) ----- 2kV
 MM (Machine Mode) ----- 200V

Recommended Operating Conditions (Note 3)

- Supply Voltage, V_{CC} ----- $5V \pm 10\%$
- Ambient Temperature Range ----- $0^\circ C$ to $70^\circ C$
- Junction Temperature Range ----- $0^\circ C$ to $125^\circ C$

Electrical Characteristics

($V_{CC} = 5V$, $T_A = 25^\circ C$, unless otherwise specified)

Parameter		Symbol	Test Conditions	Min	Typ	Max	Units
V_{CC} Supply Current							
Nominal Supply Current		I_{CC}	PWM 1,2,3 Open	--	12	--	mA
Power-On Reset							
POR Threshold		V_{CCRTTH}	V_{CC} Rising	4.0	4.2	4.5	V
Hysteresis		V_{CCHYS}		0.2	0.5	--	V
V_{DVD} Threshold	Input High	V_{DVDTP}	Enable	0.79	0.85	0.91	V
	Input Low	V_{DVDHYS}		--	250	--	mV
Oscillator							
Free Running Frequency		f_{OSC}	$R_{RT} = 12k\Omega$	170	200	230	kHz
Frequency Adjustable Range		f_{OSC_ADJ}		50	--	400	kHz
Ramp Amplitude		ΔV_{OSC}	$R_{RT} = 12k\Omega$	--	1.9	--	V
Ramp Valley		V_{RV}		--	1.0	--	V
Maximum On-Time of Each Channel				62	66	75	%
RT Pin Voltage		V_{RT}	$R_{RT} = 12k\Omega$	0.55	0.60	0.65	V
Reference and DAC							
DACOUT Voltage Accuracy		ΔV_{DAC}	$V_{DAC} \geq 1V$	-1	--	+1	%
			$V_{DAC} < 1V$	-10	--	+10	mV
DAC (VID0-VID4) Input Low		ΔV_{ILDAC}		--	--	0.8	V
DAC (VID0-VID4) Input High		ΔV_{IHDAC}		2	--	--	V

To be continued

Parameter	Symbol	Test Conditions	Min	Typ	Max	Units
DAC (VID0-VID4) Pull-up Voltage			2.2	2.4	2.6	V
DAC (VID0-VID4) Bias Current	I_{BIAS_DAC}		40	60	80	μA
VOSS Pin Voltage	V_{VOSS}	$R_{VOSS} = 100k\Omega$	0.95	1.0	1.05	V
Error Amplifier						
DC Gain			--	85	--	dB
Gain-Bandwidth Product	GBW		--	10	--	MHz
Slew Rate	SR	COMP = 10pF	--	3	--	V/ μs
Differential Sense Amplifier						
Input Impedance	Z_{IMP}		--	16	--	k Ω
Gain-Bandwidth Product	GBW		--	10	--	MHz
Slew Rate	SR		--	3	--	V/ μs
Current Sense GM Amplifier						
ISP 1,2,3 Full Scale Source Current	I_{ISPFSS}		60	--	--	μA
ISP 1,2,3 Current for OCP	I_{ISPOCP}		90	--	--	μA
Protection						
IMAX Voltage	V_{IMAX}	$R_{IMAX} = 10k$	0.55	0.60	0.65	V
SS Current	I_{SS}	$V_{SS} = 1V$	--	13	--	μA
Over-Voltage Trip (VSEN/DACOUT)	Δ_{OVT}		--	140	--	%
Power Good						
Lower Threshold (VSEN/DACOUT)	V_{PGOOD-}	VSEN Rising	--	92	--	%
Output Low Voltage	V_{PGOODL}	$I_{PGOOD} = 4mA$	--	--	0.2	V

Note 1. Stresses listed as the above "Absolute Maximum Ratings" may cause permanent damage to the device. These are for stress ratings. Functional operation of the device at these or any other conditions beyond those indicated in the operational sections of the specifications is not implied. Exposure to absolute maximum rating conditions for extended periods may remain possibility to affect device reliability.

Note 2. Devices are ESD sensitive. Handling precaution recommended.

Note 3. The device is not guaranteed to function outside its operating conditions.

Note 4. θ_{JA} is measured in the natural convection at $T_A = 25^\circ C$ on a low effective thermal conductivity test board of JEDEC 51-3 thermal measurement standard.

Typical Operating Characteristics

Current Balance

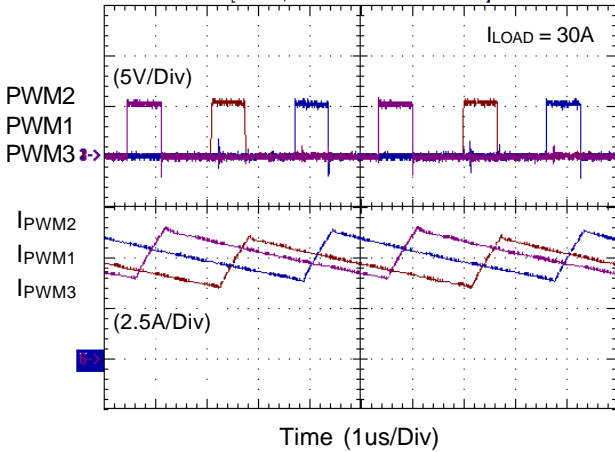

Current Balance

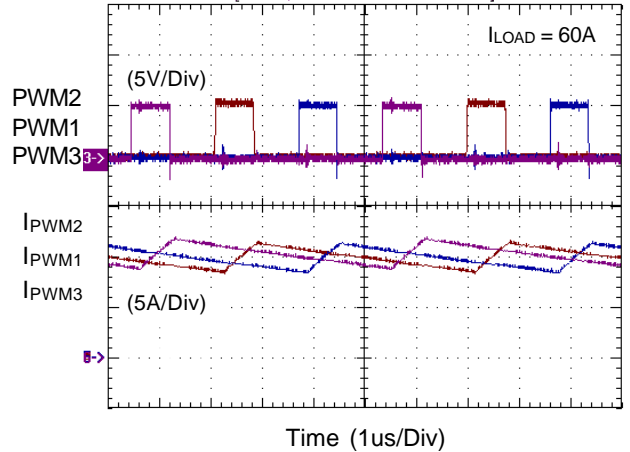

Current Balance @ Soft Start

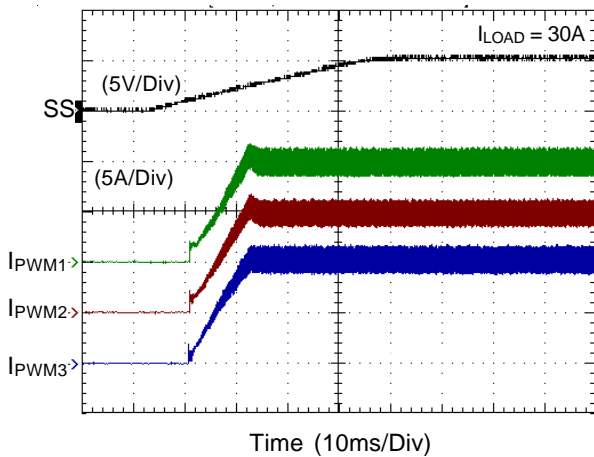

Current Balance @ Soft Start

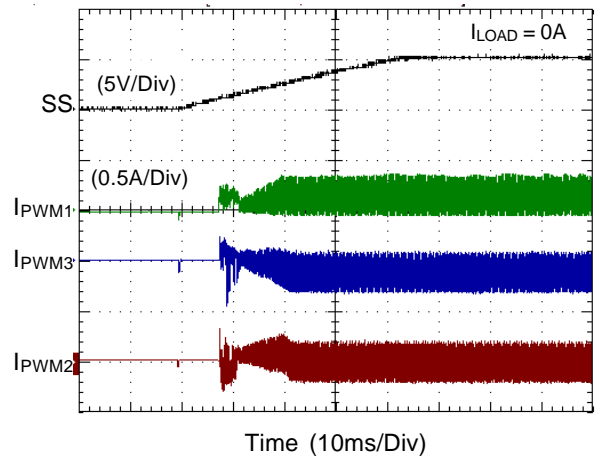

DVD Disable

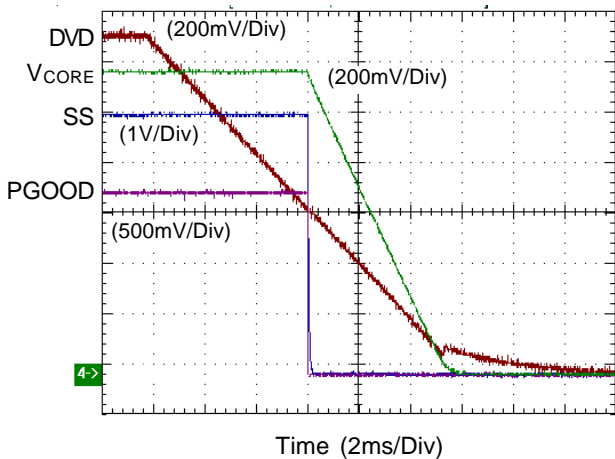

DVD Enable

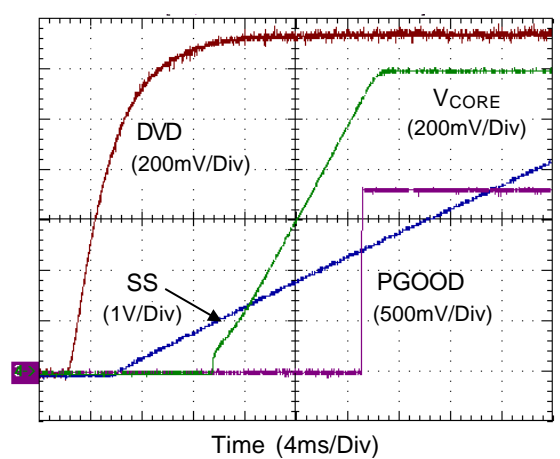

OCP Steady State

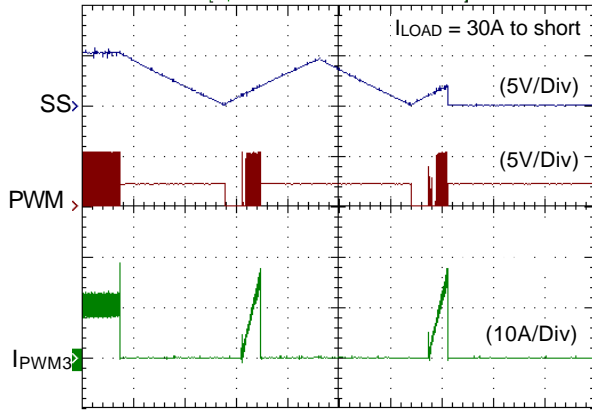

Time (20ms/Div)

OCP Power Up

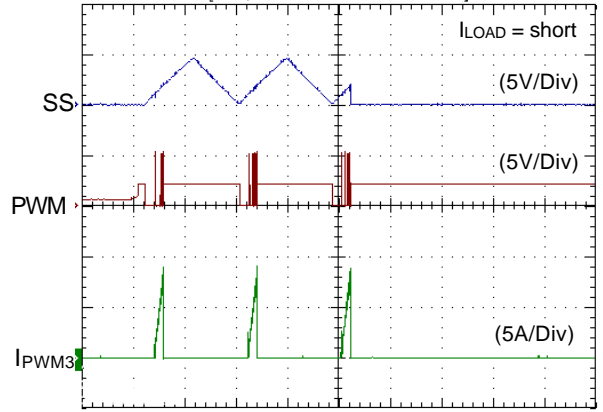

Time (40ms/Div)

Soft Start

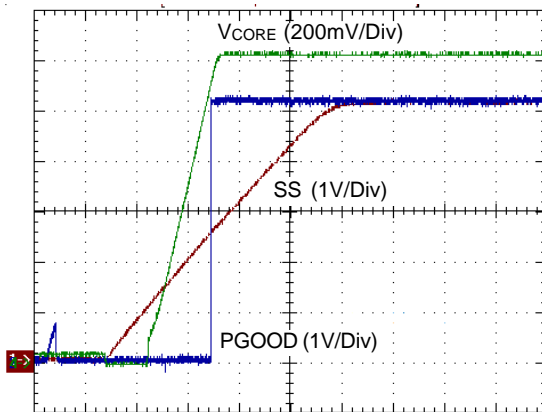

Time (10ms/Div)

Transient Response

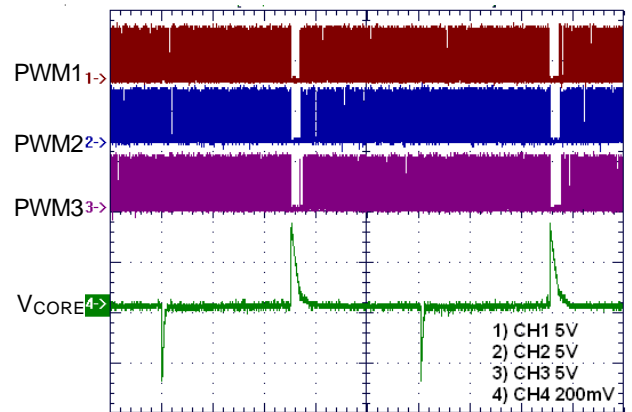

Time (200us/Div)

V_{ID} On Fly Falling

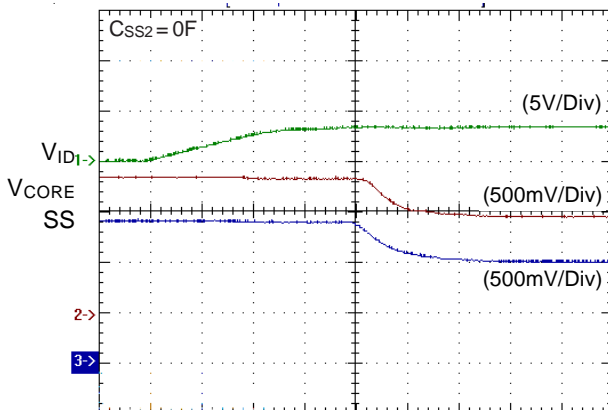

Time (200ns/Div)

V_{ID} On Fly Rising

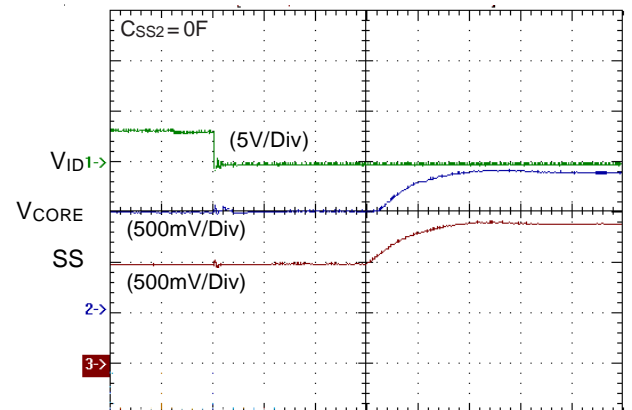

Time (200ns/Div)

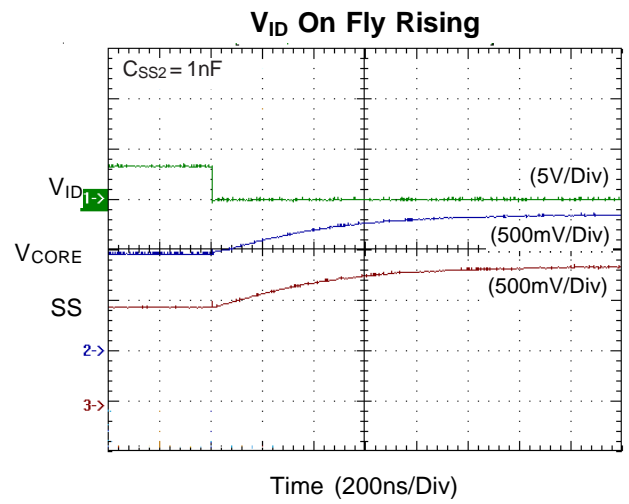
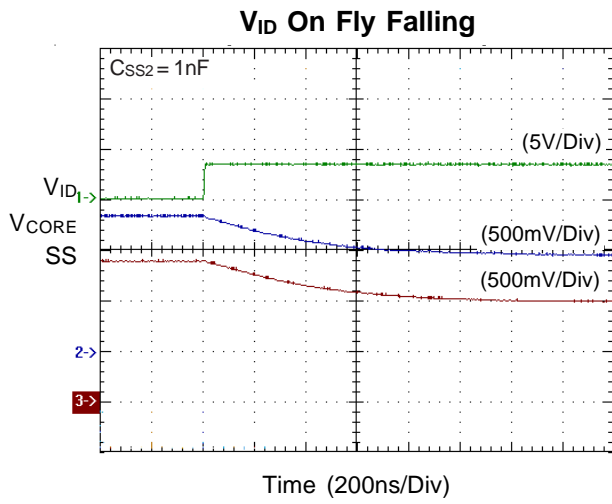

Application Information

RT9246 is a multi-phase DC/DC controller that precisely regulates CPU core voltage and balances the current of different power channels. The converter consisting of RT9246 and its companion MOSFET driver provides high quality CPU power and all protection functions to meet the requirement of modern VRM.

Voltage Control

RT9246 senses the CPU V_{CORE} by an precise instrumental amplifier to minimize the voltage drop on PCB trace at heavy load. V_{SEN} & $SGND$ are the differential inputs. V_{DIF} is the output node of the differential voltage & the input for PGOOD & OVP sense. The internal high accuracy V_{ID} DAC provides the reference voltage for K8 compliance. Control loop consists of error amplifier, multi-phase pulse width modulator, driver and power components. Like conventional voltage mode PWM controller, the output voltage is locked at the V_{REF} of error amplifier and the error signal is used as the control signal V_C of pulse width modulator. The PWM signals of different channels are generated by comparison of EA output and split-phase sawtooth wave. Power stage transforms V_{IN} to output by PWM signal on-time ratio.

Current Balance

RT9246 senses the current of low side MOSFET in each synchronous rectifier when it is conducting for channel current balance and droop tuning. The differential sensing GM amplifier converts the voltage on the sense component (can be a sense resistor or the $R_{DS(ON)}$ of the low side MOSFET) to current signal into internal balance circuit. The current balance circuit sums and averages the current signals then produces the balancing signals injected to pulse width modulator. If the current of some power channel is greater than average, the balancing signal reduces the output pulse width to keep the balance.

Load Droop

The sensed power channel current signals regulate the reference of DAC to form a output voltage droop proportional to the load current. The droop or so-called "active voltage positioning" can reduce the output voltage ripple at load transient and the LC filter size.

Fault Detection

The chip detects V_{CORE} for over voltage and power good detection. The "hiccup mode" operation of over-current protection is adopted to reduce the short circuit current. The inrush current at the start up is suppressed by the soft start circuit through clamping the pulse width and output voltage.

Phase Setting and Converter Start Up

RT9246 interfaces with companion MOSFET drivers (like RT9600, RT9602 or RT9603 series) for correct converter initialization. The tri-state PWM output (high, low and high impedance) pins sense the interface voltage at IC POR period (both V_{CC} and DVD trip). The channel is enabled if the pin voltage is 1.2V less than V_{CC} . Please tie the PWM output to V_{CC} and the current sense pins to GND or left floating if the channel is unused. For 2-Channel application, connect PWM3 high.

Current Sensing Setting

RT9246 senses the current of low side MOSFET in each synchronous rectifier when it is conducting for channel current balance and droop tuning. The differential sensing GM amplifier converts the voltage on the sense component (can be a sense resistor or the $R_{DS(ON)}$ of the low side MOSFET) to current signal into internal circuit (see Figure 1). Be careful to choose GND sense input, ISN, of the GM amplifier for effective channel current balance.

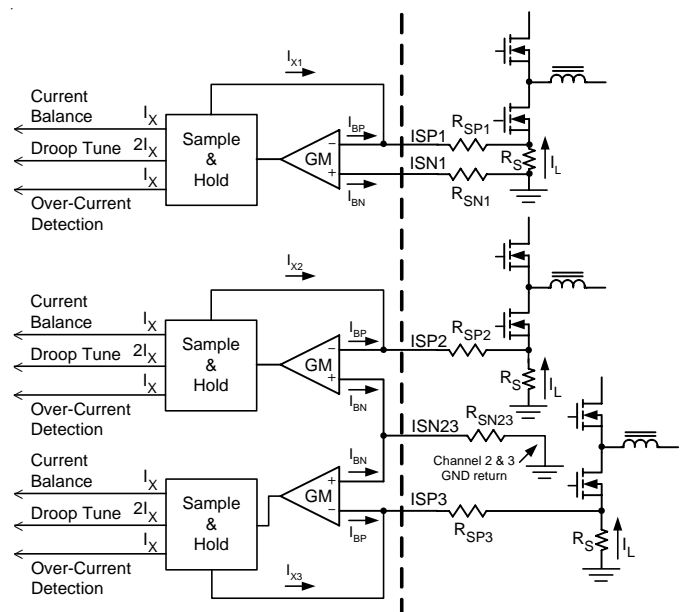

Figure 1. Current Sense Circuit

The sensing circuit gets $I_x = \frac{I_L \times R_s}{R_{SP}}$ by local feedback. $R_{SP} = R_{SN}$ for channel 1 & $R_{SP} = 2R_{SN}$ for channel 2 & 3 (at 3 phase operation) to cancel the voltage drop caused by GM amplifier input bias current. I_x is sampled and held just before low side MOSFET turns off (See Figure 2).

Therefore,

$$I_{X(S/H)} = \frac{I_{L(S/H)} \times R_s}{R_{SP}}, I_{L(S/H)} = I_{L(AVG)} - \frac{V_o}{L} \times \frac{T_{OFF}}{2}$$

$$T_{OFF} = \left[\frac{V_{IN} - V_o}{V_{IN}} \right] \times 5\mu S \text{ for } f_{osc} = 200kHz$$

$$I_{X(S/H)} = \left[I_{L(AVG)} - \frac{V_o - \left[\frac{V_{IN} - V_o}{V_{IN}} \right] \times 5\mu S}{2L} \right] \times \frac{R_s}{R_{SP}}$$

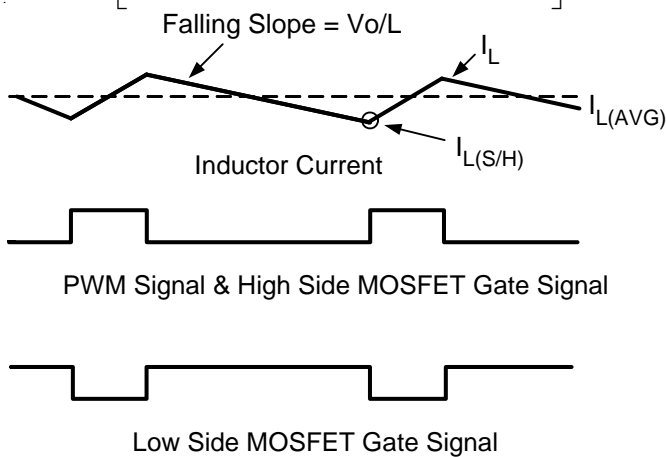

Figure 2. Inductor Current and PWM Signal

DAC Offset Voltage & Droop Tuning

The DAC offset voltage is set by compensation network & VOSS pin external resistors by $\left(\frac{1V}{R_{VOSS}} \right) \times \frac{R_{f1}}{4}$

The S/H current signals from power channels are injected to ADJ pin to create droop voltage. $V_{ADJ} = R_{ADJ} \times \sum 2I_x$

The DAC output voltage decreases by V_{ADJ} to form the V_{CORE} load droop (see Figure 3).

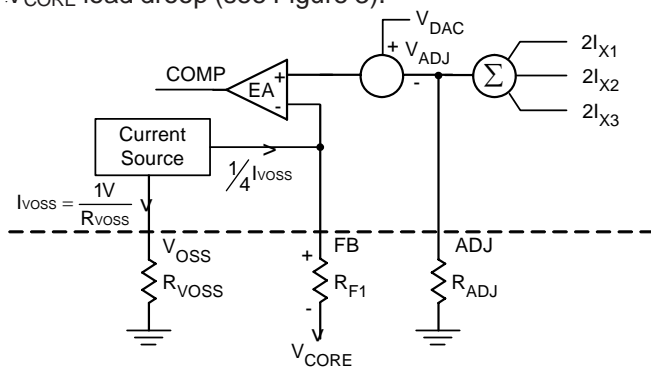

Figure 3. DAC Offset Voltage & Droop Tune Circuit

Protection and SS Function

For OVP, the RT9246 detects the V_{CORE} by V_{DIF} pin voltage of the differential amplifier output. Eliminate the delay due to compensation network (compared to sensing FB voltage) for fast and accurate detection. The trip point of OVP is 140% of normal output level. The PWM outputs are pulled low to turn on the low side MOSFET and turn off the high side MOSFET of the synchronous rectifier at OVP. The OVP latch can only be reset by V_{CC} or DVD restart power on reset sequence. The PGOOD detection trip point of V_{CORE} is 92% lower than the normal level. The PGOOD open drain output pulls low when V_{CORE} is lower than the trip point. For V_{ID} jumping issue, only power fail conditions (V_{CC} & DVD are lower than trip point or OVP) reset the output low.

Soft-start circuit generates a ramp voltage by charging external capacitor with 13 μ A current after IC POR acts. The PWM pulse width and V_{CORE} are clamped by the rising ramp to reduce the inrush current and protect the power devices.

Over-current protection trip point is set by the resistor R_{IMAX} connected to IMAX pin. OCP is triggered if one channel

S/H current signal $I_x > \left(\frac{0.6V}{R_{IMAX}} \right) \times 1.4$. Controller forces PWM output latched at high impedance to turn off both high and low side MOSFETs in the power stage and initial the hiccup mode protection. The SS pin voltage is pulled low with a 13 μ A current after it is less than 90% V_{CC} . The converter restarts after SS pin voltage < 0.2V. Three times of OCP disable the converter and only release the latch by POR acts (see Figure 4).

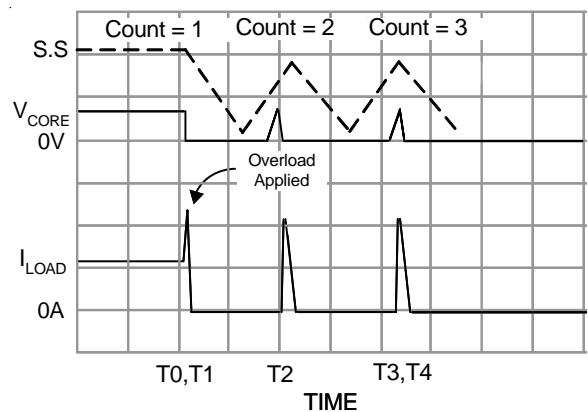
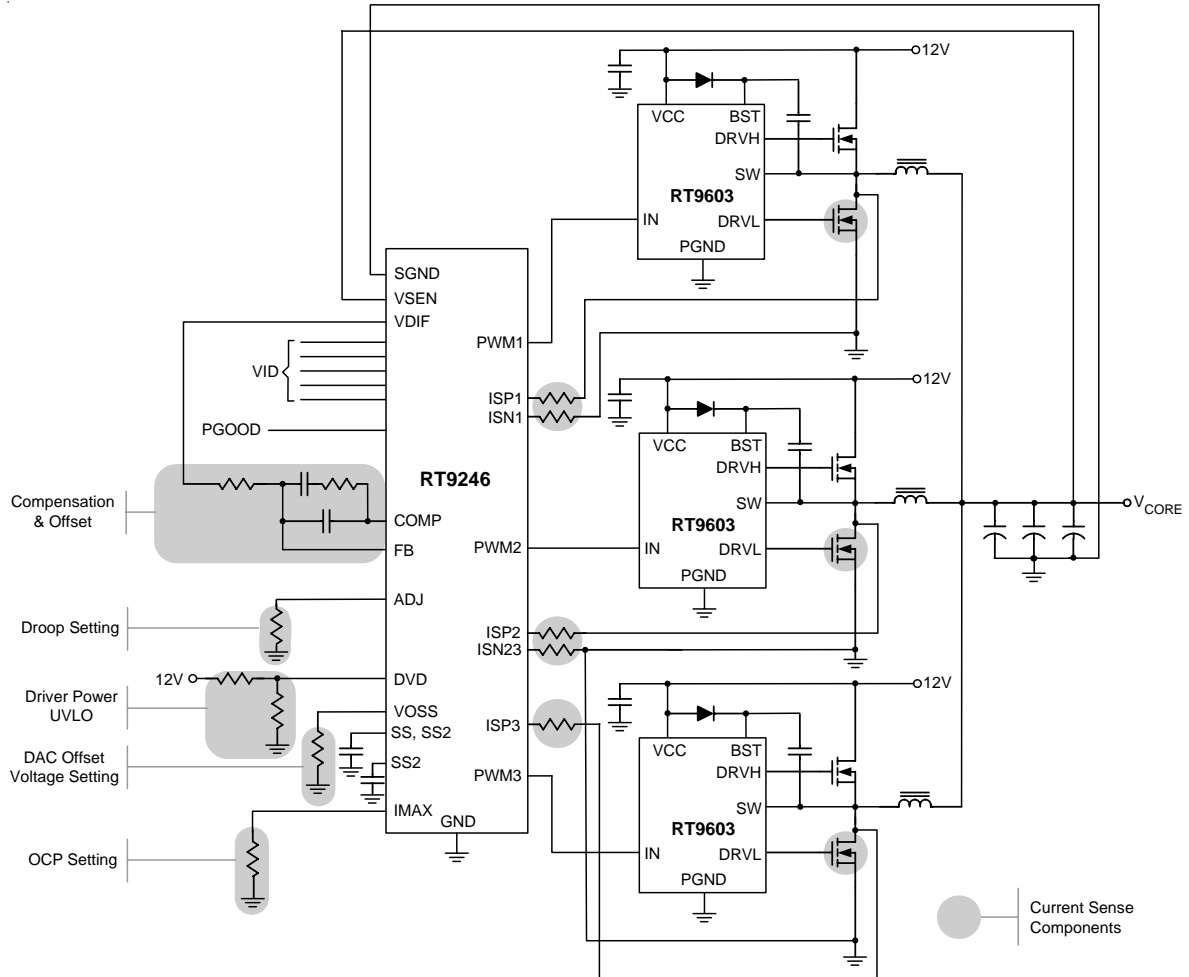

Figure 4.

3-Phase Converter and Components Function Grouping



Design Procedure Suggestion

Voltage Loop Setting

- a. Output filter pole and zero (Inductor, output capacitor value & ESR).
- b. Error amplifier compensation & sawtooth wave amplitude (compensation network).
- c. Kelvin sense for V_{CORE} .

Current Loop Setting

- a. GM amplifier S/H current (current sense component $R_{DS(ON)}$, ISP_x & ISN_x pin external resistor value, keep ISP_x current < $60\mu A$ at full load condition for better load line linearity).
- b. Over-current protection trip point ($IMAX$ pin resistor, keep ISP_x current < $90\mu A$ at OCP condition for precision issue).

VRM Load Line Setting

- a. Droop amplitude (ADJ pin resistor).
- b. No load offset (additional resistor in compensation network).
- c. DAC offset voltage setting ($VOSS$ pin & compensation network resistor).

Power Sequence & SS

DVD pin external resistor and SS pin capacitor.

PCB Layout

- a. Kelvin sense for current sense GM amplifier input.
- b. Refer to layout guide for other item.

Design Example

Given:

- Apply for three phase converter
- $V_{IN} = 12V$
- $V_{CORE} = 1.5V$
- $I_{LOAD} (max) = 60A$
- $V_{DROOP} = 120mV$ at full load
- OCP trip point set at 30A for each channel (S/H)
- $R_{DS(ON)} = 6m\Omega$ of low side MOSFET at 27°C
- $L = 2\mu H$
- $C_{OUT} = 9,000\mu F$ with 2mΩ ESR.

1. Compensation Setting

a. Modulator Gain, Pole and Zero:

From the following formula:

$$\text{Modulator Gain} = \frac{V_{IN}}{V_{RAMP}} = \frac{12V}{1.9V \times \frac{3}{2}} = 4.2 \text{ (12.46dB)}$$

where V_{RAMP} : ramp amplitude of sawtooth wave

$$\text{LC Filter Pole} = \frac{1}{2\pi \times \sqrt{LC}} = 1.2kHz \text{ and}$$

$$\text{ESR Zero} = \frac{1}{2\pi \times \text{ESR} \times C_{OUT}} = 8.8kHz$$

b. EA Compensation Network:

Select $R1 = 2.4k\Omega$, $R2 = 24k\Omega$, $C1 = 6.6nF$, $C2 = 33pF$ and use the type 2 compensation scheme shown in Figure 5.

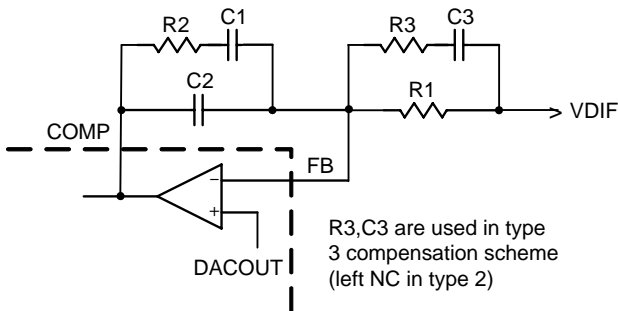

Figure 5.

From the following formulas:

$$F_z = \frac{1}{2\pi \times R_2 \times C_1}, F_p = \frac{1}{2\pi \times R_2 \times \left(\frac{C_1 \times C_2}{C_1 + C_2} \right)}$$

$$\text{Middle Band Gain} = \frac{R_2}{R_1}$$

By calculation, the $F_z = 1kHz$, $F_p = 200kHz$ and Middle Band Gain is 10 (i.e 20dB).

The asymptotic bode plot of EA compensation and PWM loop gain is shown as Figure 6.

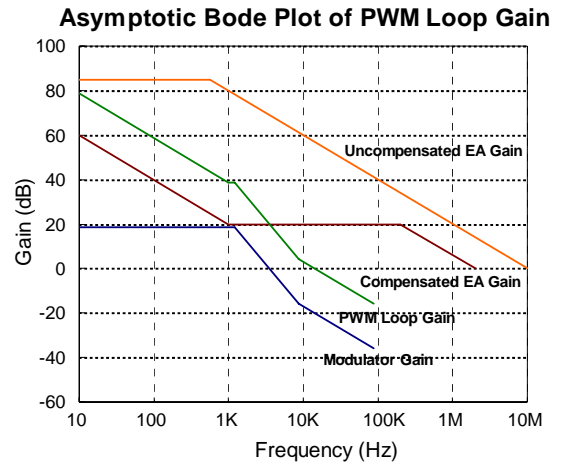

Figure 6.

2. Droop & DAC Offset Setting

For each channel the load current is $60A / 3 = 20A$ and the ripple current, ΔI_L , is given as:

$$5\mu s \times \frac{1.5V}{2\mu H} \times \left(1 - \frac{1.5V}{12V} \right) = 3.28A$$

The load current, I_L , at S/H is $20A - \frac{\Delta I_L}{2} = 18.36A$. Using the following formula to select the appropriate $I_X (MAX)$ for the S/H of GM amplifier:

$$I_X (MAX) = \frac{R_{DS(ON)} \times 18.36A}{R_{SP}}$$

The suggested I_X is in the order of 40 to 50μA, select $R_{SP} = R_{SN} = 2.4k\Omega$, then $I_X (MAX)$ will be 45.9μA. $V_{DROOP} = 120mV = 45.9\mu A \times 2 \times 3$ (phase no.) $\times R_{ADJ}$, therefore R_{ADJ} will be 435Ω.

The $R_{DS(ON)}$ of MOSFET varies with temperature rise. When the low side MOSFET working at 70°C and 5000ppm/°C temperature coefficient of $R_{DS(ON)}$, the $R_{DS(ON)}$ at 70°C is given as:

$$6m\Omega \times \{1 + (70^\circ C - 27^\circ C) \times 5000ppm/^\circ C\} = 7.3m\Omega.$$

R_{ADJ} at 70°C is given as:

$$R_{ADJ_27^\circ C} \times (R_{DS(ON)_27^\circ C} / R_{DS(ON)_70^\circ C}) = 358\Omega$$

3. Over-Current Protection Setting

OCP trip point set at 30A for each channel,

$$I_X = \frac{R_{DS(ON)} \times 30A}{R_{SP}} = 1.4 \times \frac{0.6V}{R_{IMAX}}, R_{IMAX} = 11.2k\Omega$$

Take the temperature rise into account, the R_{IMAX} at 70°C will be:

$$R_{IMAX_27^\circ C} \times (R_{DS(ON)_27^\circ C} / R_{DS(ON)_70^\circ C}) = 9.2k\Omega$$

4. Soft-Start Capacitor Selection

$C_{SS} = 0.1\mu F$ is the suitable value for most application.

Layout Guide

Place the high-power switching components first, and separate them from sensitive nodes.

1. **Most critical path: the current sense circuit is the most sensitive part of the converter. The current sense resistors tied to ISP1,2,3 and ISN1,ISN2,3 should be located not more than 0.5 inch from the IC and away from the noise switching nodes. The PCB trace of sense nodes should be parallel and as short as possible. Kelvin connection of the sense component (additional sense resistor or MOSFET $R_{DS(ON)}$) ensures the accurate stable current sensing.**

Keep well Kelvin sense to ensure the stable operation!

2. Switching ripple current path:
 - a. Input capacitor to high side MOSFET.
 - b. Low side MOSFET to output capacitor.
 - c. The return path of input and output capacitor.
 - d. Separate the power and signal GND.
 - e. The switching nodes (the connection node of high/low side MOSFET and inductor) is the most noisy points. Keep them away from sensitive small-signal node.
 - f. Reduce parasitic R, L by minimum length, enough copper thickness and avoiding of via.
3. MOSFET driver should be closed to MOSFET.
4. The compensation, bypass and other function setting components should be near the IC and away from the noisy power path.

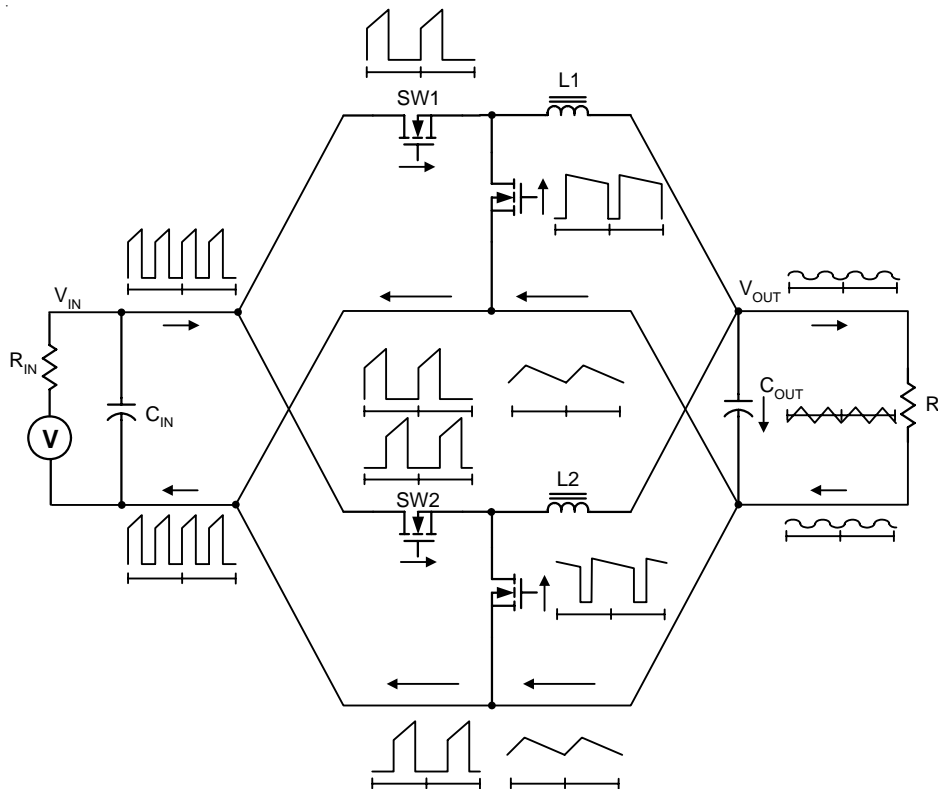

Figure 7. Power Stage Ripple Current Path

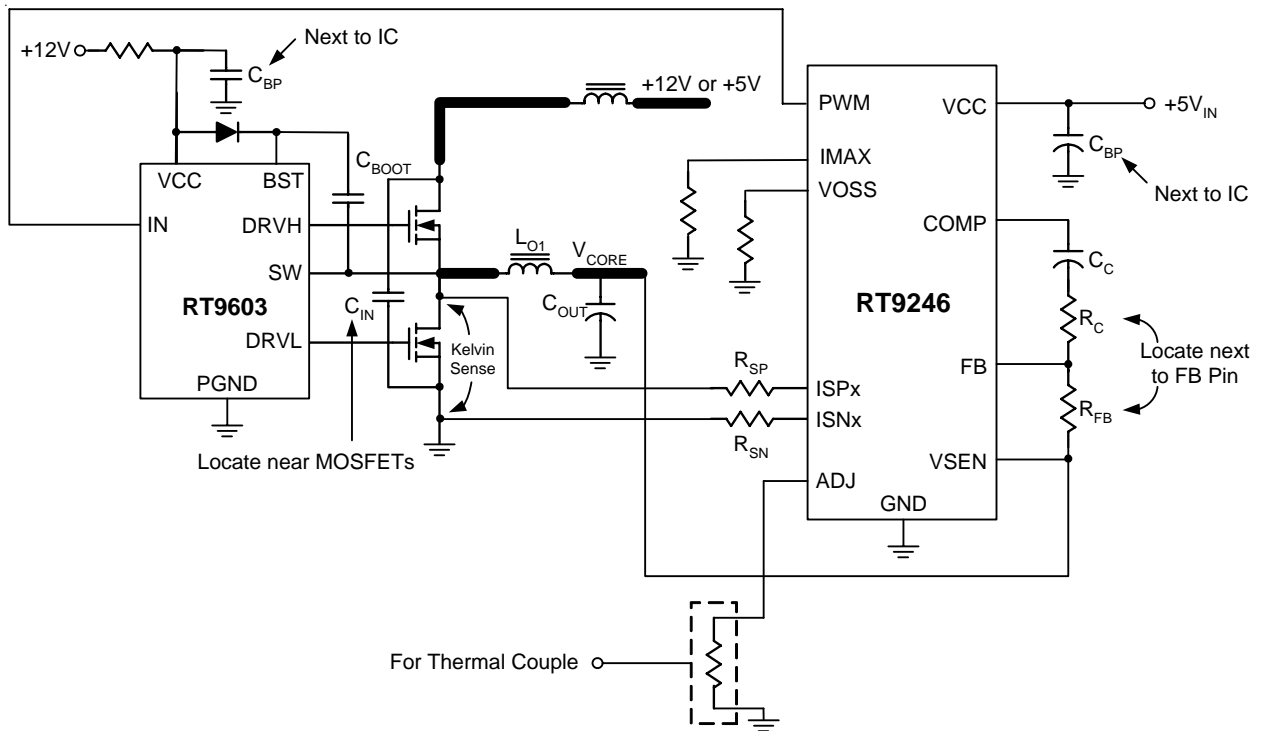
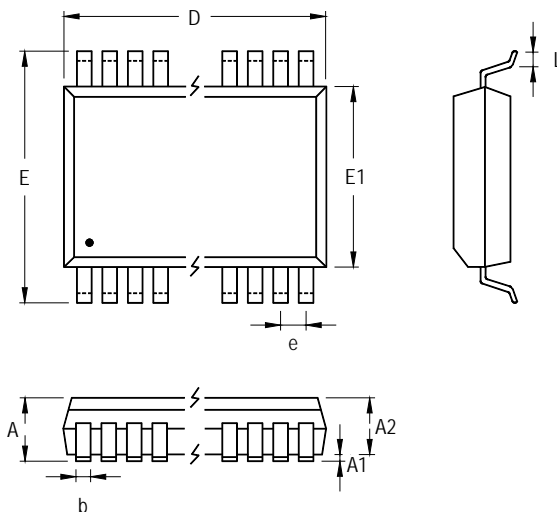

Figure 8. Layout Consideration

Outline Dimension



Symbol	Dimensions In Millimeters		Dimensions In Inches	
	Min	Max	Min	Max
A	0.850	1.200	0.033	0.047
A1	0.050	0.152	0.002	0.006
A2	0.800	1.050	0.031	0.041
b	0.178	0.305	0.007	0.012
D	9.601	9.804	0.378	0.386
e	0.650		0.026	
E	6.300	6.500	0.248	0.256
E1	4.293	4.496	0.169	0.177
L	0.450	0.762	0.018	0.030

28-Lead TSSOP Plastic Package

RICHTEK TECHNOLOGY CORP.

Headquarter
 5F, No. 20, Taiyuen Street, Chupei City
 Hsinchu, Taiwan, R.O.C.
 Tel: (8863)5526789 Fax: (8863)5526611

RICHTEK TECHNOLOGY CORP.

Taipei Office (Marketing)
 8F-1, No. 137, Lane 235, Paochiao Road, Hsintien City
 Taipei County, Taiwan, R.O.C.
 Tel: (8862)89191466 Fax: (8862)89191465
 Email: marketing@richtek.com