



Product Specification

PE3291

1200 MHz / 550 MHz Dual Fractional-N FlexiPower™ PLL for Frequency Synthesis

Features

- Ultra-Low Power via FlexiPower variable supply voltages
- Modulo-32 fractional-N main counters
- On-board fractional spur compensation: No tuning required, stable over temperature
- Improved phase noise compared to integer-N architectures

Applications

- CDMA handsets
- CDMA base stations
- Analog Cordless phones
- One and two way pagers

Product Description

The PE3291 is a dual fractional-N FlexiPower™ phase-lock loop (PLL) IC designed for frequency synthesis. Each PLL includes a FlexiPower™ prescaler, phase detector, charge pump and on-board fractional spur compensation.

The FlexiPower prescalers are supplied power on dedicated pins and can operate at a substantial power savings at voltages as low as 0.8 volts, while allowing a 3 volt charge pump supply. For 3 volt only systems, on-chip voltage regulation may be used to generate the prescaler power supplies.

Figure 1 illustrates the implementation of the FlexiPower technology. The prescaler power supply may be provided externally or internally regulated down from V_{DD} . In a typical 950 MHz application the total current consumed by the PLL is 2.1 mA. Operation at reduced current levels provides significant battery life extension. The PE3291 allows the system designer to minimize power consumption by controlling the voltage on the prescaler. For additional operating speeds and current consumptions refer to Figures 5 and 6.

PE3291 provides fractional-N division with power-of-two denominator values up to 32. This allows comparison frequencies up to 32 times the channel spacing, providing a lower phase noise floor than integer PLLs. The 32/33 RF prescaler (PLL1) operates up to 1200 MHz and the 16/17 IF prescaler (PLL2) operates up to 550 MHz.

The PE3291 Phase Locked-Loop is manufactured on Peregrine's UltraCMOS™ process, a patented variation of silicon-on-insulator (SOI) technology on a sapphire substrate, offering the performance of GaAs with the economy and integration of conventional CMOS.

Figure 1: FlexiPower technology enables the prescaler to operate at voltages down to 0.8 volts. This significantly reduces the total power.

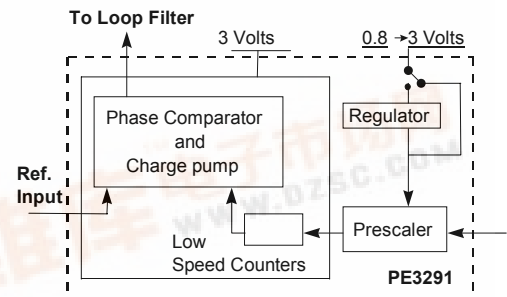

Figure 2. Pin Configurations (Top View)

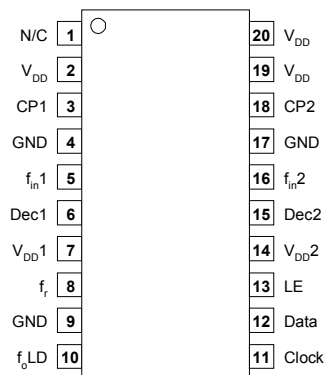

Figure 3. Package Type

20-lead TSSOP

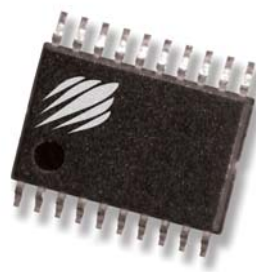

Table 1. Pin Descriptions

Pin No.	Pin Name	Type	Description
1	N / C		No connect.
2	V _{DD}	(Note 1)	Power supply voltage input. Input may range from 2.7 V to 3.3 V. A bypass capacitor should be placed as close as possible to this pin and be connected directly to the ground plane.
3	CP1	Output	Internal charge-pump output from PLL1 for connection to a loop filter for driving the input of an external VCO.
4	GND		Ground.
5	f _{in1}	Input	Prescaler input from the PLL1 (RF) VCO. Maximum frequency is 1.2 GHz.
6	Dec1		Power supply decoupling pin for PLL1. A capacitor should be placed as close as possible to this pin and be connected directly to the ground plane.
7	V _{DD1}		PLL1 prescaler power supply (FlexiPower 1).
8	f _r	Input	Reference frequency input.
9	GND		Ground.
10	f _{oLD}	Output	Multiplexed output of the PLL1 and PLL2 main counters or reference counters, Lock Detect signals, and data out of the shift register. CMOS output (see Table 11, f _{oLD} Programming Truth Table).
11	Clock	Input	CMOS clock input. Serial data for the various counters is clocked in on the rising edge into the 21-bit shift register.
12	Data	Input	Binary serial data input. CMOS input data entered MSB first. The two LSBs are the control bits.
13	LE	Input	Load Enable CMOS input. When LE is high, data word stored in the 21-bit serial shift register is loaded into one of the four appropriate latches (as assigned by the control bits).
14	V _{DD2}	Output	PLL2 prescaler power supply (FlexiPower 2).
15	Dec2	Output	Power supply decoupling pin for PLL2. A capacitor should be placed as close as possible to this pin and be connected directly to the ground plane.
16	F _{in2}	Input	Prescaler input from the PLL2 (IF) VCO. Maximum frequency is 550 MHz.
17	GND		Ground.
18	CP2	Output	Internal charge-pump output for PLL2. For connection to a loop filter for driving the input of an external VCO.
19	V _{DD}	(Note 1)	Same as pin 2.
20	V _{DD}	(Note 1)	Same as pin 2.

Note 1: V_{DD} pins 2, 19, and 20 are connected by diodes and must be supplied with the same voltage level.

PE3291 Description

The PE3291 is intended for such applications as the local oscillator for the RF and first IF of dual-conversion transceivers. The RF PLL (PLL1) includes a 32/33 prescaler with a 1200 MHz maximum frequency of operation, where the IF PLL (PLL2) incorporates a 16/17 prescaler with a 550 MHz maximum frequency of operation. Using an advanced fractional-N phase-locked loop technique, the PE3291 can generate a stable, very low phase-noise signal. The dual fractional architecture allows fine resolution in both PLLs, with no degradation in phase noise performance.

Data is transferred into the PE3291 via a three-wire interface (Data, Clock, LE). Supply voltage can range from 2.7 to 3.3 volts for V_{DD} and from 0.8 to 3.3 volts for the FlexiPower supply. PE3291 features very low power consumption and is available in a 20-lead TSSOP (JEDEC MO-153-AC) package.

FlexiPower Operation

Each FlexiPower PLL prescaler can be supplied its own dedicated supply voltage as low as 0.8 volts for substantial power savings. The maximum frequency of operation scales with the FlexiPower supply voltage. If voltages less than V_{DD} are not available, the FlexiPower supplies can be internally generated, but the power savings will not be as great as when using external FlexiPower supplies.

Spurious Response

A critical parameter for synthesizer designs is spurious output. Spurs occur at the integer multiples of the step size away from center tone. An important feature of fractional synthesizers is their ability to reduce these spurious sidebands. The PE3291 has a built-in method for reducing these spurs, with no external components or tuning required. In addition, this circuitry works over the full commercial temperature range.

Figure 4. PE3291 Block Diagram

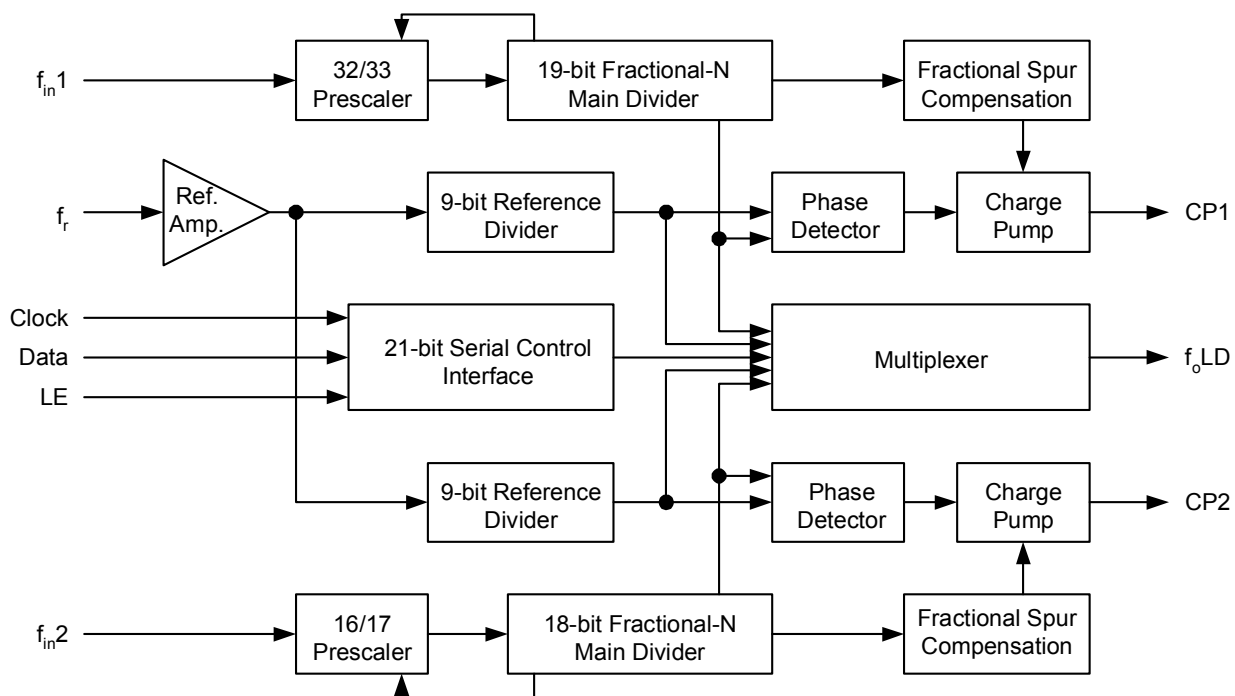

Table 2. Absolute Maximum Ratings

Symbol	Parameter/Conditions	Min	Max	Units
V_{DD}	Supply voltage	-0.3	4.0	V
V_I	Voltage on any input	-0.3	$V_{DD} + 0.3$	V
I_I	DC into any input	-10	+10	mA
I_O	DC into any output	-10	+10	mA
T_{stg}	Storage temperature range	-65	150	°C

Absolute Maximum Ratings are those values listed in the above table. Exceeding these values may cause permanent device damage. Functional operation should be restricted to the limits in the DC and AC Characteristics table. Exposure to absolute maximum ratings for extended periods may affect device reliability.

Latch-Up Avoidance

Unlike conventional CMOS devices, UltraCMOS™ devices are immune to latch-up.

Table 3. Operating Ratings

Symbol	Parameter/Conditions	Min	Max	Units
V_{DD}	Supply voltage	2.7	3.3	V
T_A	Operating ambient	-40	85	°C

Table 4. ESD Ratings

Symbol	Parameter/Conditions	Level	Units
V_{ESD}	ESD voltage human body model	1000	V

Note 1: Periodically sampled, not 100% tested. Tested per MIL-STD-883, M3015 C2

Electrostatic Discharge (ESD) Precautions

When handling this UltraCMOS™ device, observe the same precautions that you would use with other ESD-sensitive devices. Although this device contains circuitry to protect it from damage due to ESD, precautions should be taken to avoid exceeding the specified rating in Table 4.

Table 5. DC Characteristics: $V_{DD} = 3.0\text{ V}$, $-40^\circ\text{ C} < T_A < 85^\circ\text{ C}$, unless otherwise specified

Symbol	Parameter	Conditions	Min	Typ	Max	Units	
I_{DD}	3 V supply current when V_{DD1} and V_{DD2} are internally regulated down from V_{DD} (note 1)	(10 MHz Ref. Freq.) $P_2, P_1 = 01$ RF RF PLL1 low speed		1.4		mA	
		$P_2, P_1 = 1X$ RF PLL1 high speed		2.0		mA	
		$C_{10}, C_{20} = 01$ IF PLL2 off					
		$P_2, P_1 = 01$ RF PLL1 low speed			2.1		mA
		$C_{10}, C_{20} = 00$ IF PLL2 low speed					
I_{DD}	3 V supply current when V_{DD1} and V_{DD2} are externally supplied (note 1)	$P_2, P_1 = 10$ RF PLL1 high speed		2.7		mA	
		$C_{10}, C_{20} = 00$ IF PLL2 low speed					
I_{DD}		$P_2, P_1 = 11$ RF PLL1 high speed		3.1		mA	
		$C_{10}, C_{20} = 00$ IF PLL2 high speed					
I_{DD}		$P_2, P_1 = 00$ 2 PLL's enabled		1.0		mA	
		1 PLL enabled		0.7		mA	
I_{DD1}	PLL1 FlexiPower Prescaler supply current (see fig. 5)	$P_2, P_1 = 00$ PLL1 enabled		0.5		mA	
		$V_{DD1} = 1/0$ volt		1.5		mA	
		$V_{DD1} = 1.8$ volts		4.0		mA	
		$V_{DD1} = 2.7$ volts					
I_{DD2}	PLL2 FlexiPower Prescaler supply current (see fig. 5)	$P_2, P_1 = 00$ PLL2 enabled		0.4		mA	
		$V_{DD2} = 1.0$ volt		1.2		mA	
		$V_{DD2} = 1.8$ volts		2.0		mA	
		$V_{DD2} = 2.7$ volts					
I_{stby}	Total standby current			5	50	mA	
Digital inputs: Clock, Data, LE							
V_{IH}	High level input voltage	$V_{DD} = 2.7$ to 3.3 volts	$0.7 \times V_{DD}$			V	
V_{IL}	Low level input voltage	$V_{DD} = 2.7$ to 3.3 volts			$0.3 \times V_{DD}$	V	
I_{IH}	High level input current	$V_{IH} = V_{DD} = 3.3$ volts	-1		+1	mA	
I_{IL}	Low level input current	$V_{IL} = 0, V_{DD} = 3.3$ volts	-1		+1	mA	

Note 1: The total current consumed by the device is I_{DD} when internal regulation is employed and $I_{DD} + I_{DD1} + I_{DD2}$ when V_{DD1} and V_{DD2} are externally supplied. When V_{DD1} and V_{DD2} are internally generated, pins 7 and 14 should be left floating.

Table 5. DC Characteristics (continued): $V_{DD} = 3.0\text{ V}$, $-40^\circ\text{ C} < T_A < 85^\circ\text{ C}$, unless otherwise specified

Symbol	Parameter	Conditions	Min	Typ	Max	Units
Reference Divider input: f_r						
I_{IHR}	Input current	$V_{IH} = V_{DD} = 3.6\text{ volts}$			+25	mA
I_{ILR}	Input current	$V_{IL} = 0, V_{DD} = 3.6\text{ volts}$	-25			mA
Digital output: f_oLD						
V_{OLD}	Output voltage LOW	$I_{out} = 1\text{ mA}$				V
V_{OHD}	Output voltage HIGH	$I_{out} = -1\text{ mA}$	$V_{DD}-0.4$			V
Charge Pump outputs: CP1, CP2						
$I_{CP - Source}$	Drive current	$V_{CP} = V_{DD} / 2$		-70		mA
$I_{CP - Sink}$				70		mA
I_{CPL}	Leakage current	$0.5\text{ V} < V_{CP} < V_{DD}-0.5\text{ volt}$	-5		5	nA
$I_{CP - Source}$ vs.	Sink vs. Source mismatch	$V_{CP} = V_{DD} / 2, T_A = 25^\circ\text{ C}$			10	%
I_{CP} vs. T_A	Output current vs. temperature	$V_{CP} = V_{DD} / 2$		10		%
I_{CP} vs. V_{CP}	Output current magnitude variation vs. voltage	$0.5\text{ V} < V_{CP} < V_{DD} - 0.5\text{ volt}, T_A = 25^\circ\text{ C}$		10		%

Figure 5. Prescaler Current vs. FlexiPower Voltage (V_{DD1} and V_{DD2} externally supplied)

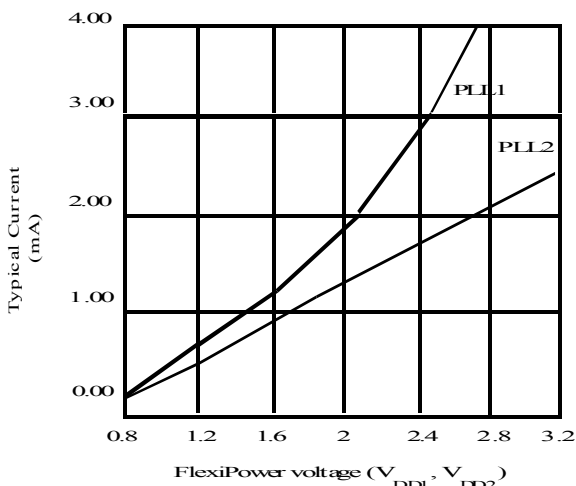

Table 6. AC Characteristics: $V_{DD} = 3.0\text{ V}$, $-40^\circ\text{ C} < T_A < 85^\circ\text{ C}$, unless otherwise specified

Symbol	Parameter	Conditions	Min	Max	Units
Control Interface and Latches (see figure 8)					
f_{clk}	Serial data clock frequency			10	MHz
t_{clockH}	Serial clock HIGH time		50		ns
t_{clockL}	Serial clock LOW time		50		ns
t_{DSU}	Data set-up time to Clock rising edge		50		ns
t_{DHLD}	Data hold time after Clock rising edge		10		ns
t_{LEW}	LE pulse width		50		ns
t_{CLE}	Clock falling edge to LE rising edge		50		ns
t_{LEC}	LE falling edge to Clock rising edge		50		ns
$t_{Data Out}$	Data Out delay after Clock falling edge (f_oLD pin)	$C_L = 50\text{ pf}$		90	ns

Table 6. AC Characteristics (continued): $V_{DD} = 3.0\text{ V}$, $-40^\circ\text{ C} < T_A < 85^\circ\text{ C}$, unless otherwise specified

Symbol	Parameter	Conditions	Min	Max	Units
Main Divider (Including Prescaler)					
f_{in1}	Operating frequency (see figure 6)	$P_2, P_1 = 00$ $V_{DD1} = 1.0\text{ volts}$	300	450	MHz
		$V_{DD1} = 1.8\text{ volts}$	300	900	MHz
		$V_{DD1} = 2.7\text{ volts}$	300	1200	MHz
		$P_2, P_1 = 01$ $V_{DD1} = \text{internally generated (low speed)}$	300	800	MHz
		$P_2, P_1 = 1X = (10\text{ or }11)$ $V_{DD1} = \text{internally generated (high speed)}$	300	1100	MHz
f_{in2}	Operating frequency (see figure 6)	$P_2, P_1 = 00$ $V_{DD1} = 1.0\text{ volts}$	45	300	MHz
		$V_{DD1} = 1.8\text{ volts}$	45	550	MHz
		$V_{DD1} = 2.7\text{ volts}$	45	550	MHz
		$P_2, P_1 = 01\text{ or }10$ $V_{DD2} = \text{internally generated (low speed)}$	45	300	MHz
		$P_2, P_1 = 11$ $V_{DD1} = \text{internally generated (high speed)}$	45	550	MHz
Pf_{in1}	Input level range	External AC coupling	-10	5	dBm
Pf_{in2}	Input level range	External AC coupling	-10	5	dBm
f_c	Comparison frequency			10	MHz
Reference Divider					
f_r	Operating frequency			50	MHz
V_{fr}	Input sensitivity	External AC coupling (note 1)	0.5		V_{P-P}

Note 1: CMOS logic levels may be used if DC coupled

Figure 6. PLL Maximum Frequency vs. FlexiPower Voltage

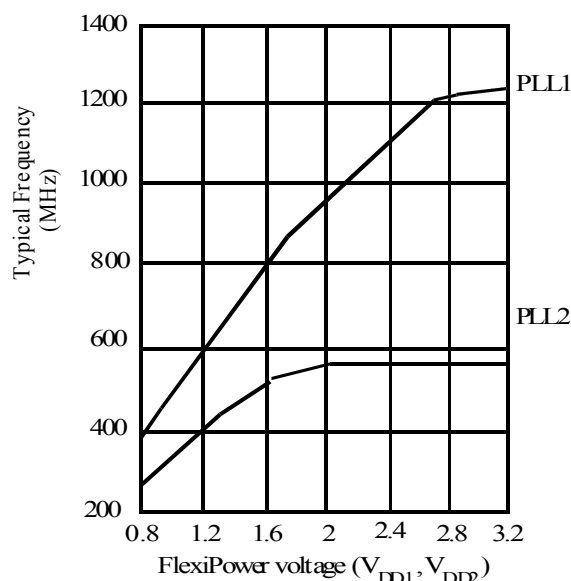

Functional Description

The Functional Block Diagram in Figure 7 shows a 21-bit serial control register, a multiplexed output, and PLL sections PLL1 and PLL2. Each PLL contains a fractional-N main counter chain, a reference counter, a phase detector, and an internal charge pump with on-chip fractional spur compensation. Each fractional-N main counter chain includes an internal dual modulus prescaler, supporting counters, and a fractional accumulator.

Serial input data is clocked on the rising edge of Clock, MSB first. The last two bits are the address bits that determine the register address. Data is transferred into the counters as shown in Table 8, PE3291 Register Set. If the f_oLD pin is configured as data out, then the contents of shift register bit S_{20} are clocked on the falling edge of Clock onto the f_oLD pin. This feature allows the PE3291 and compatible devices to be connected in a daisy-chain configuration.

The PLL1 (RF) VCO frequency f_{in1} is related to

the reference frequency f_r by the following equation:

$$f_{in1} = [(32 \times M_1) + A_1 + (F_1/32)] \times (f_r/R_1)$$

(1) Note that A_1 must be less than M_1 . Also, f_{in1} must be greater than or equal to $1024 \times (f_r/R_1)$ to obtain contiguous channels.

The PLL2 (IF) VCO frequency f_{in2} is related to the reference frequency f_r by the following equation:

$$f_{in2} = [(16 \times M_2) + A_2 + (F_2/32)] \times (f_r/R_2)$$

(2) Note that A_2 must be less than M_2 . Also, f_{in2} must be greater than or equal to $256 \times (f_r/R_2)$ to obtain contiguous channels.

F_1 sets PLL1 fractionality. If F_1 is an even number, the PE3291 automatically reduces the fraction. For example, if $F_1 = 12$, then the fraction $12/32$ is automatically reduced to $3/8$. In this way, fractional denominators of 2, 4, 8, 16 and 32 are available. F_2 sets the fractionality for PLL2 in the same manner.

Figure 7. Functional Block Diagram

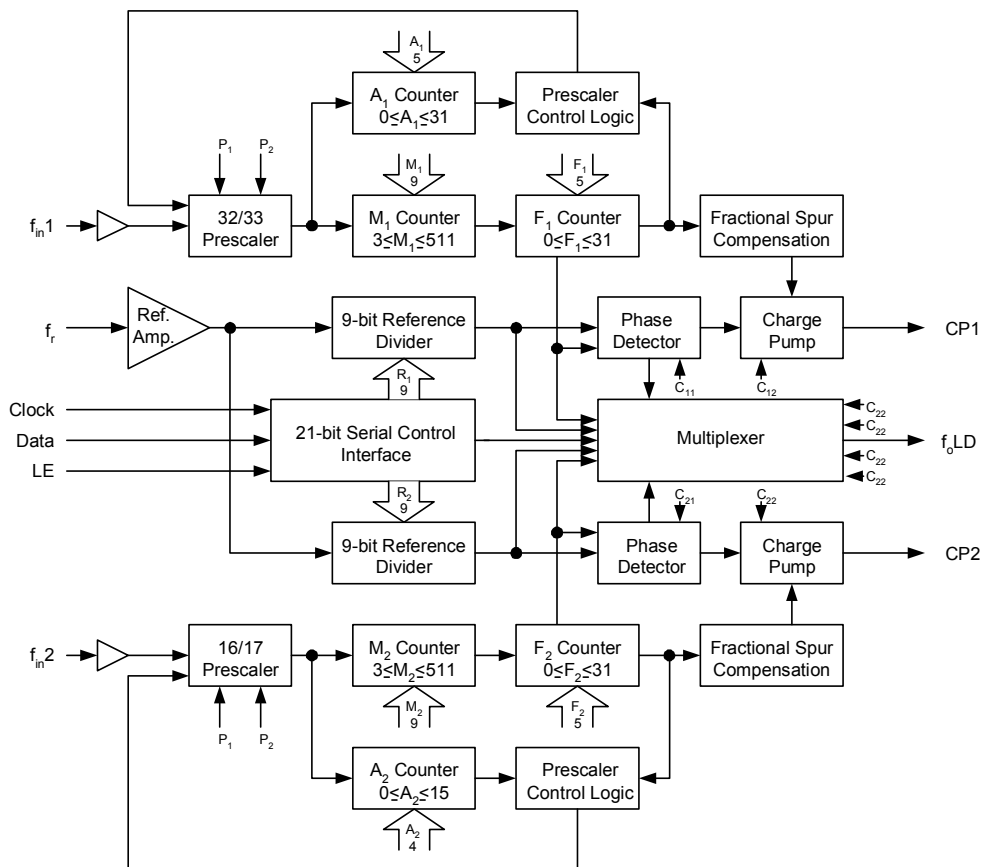

Table 7. Register Set

S ₂₀	S ₁₉	S ₁₈	S ₁₇	S ₁₆	S ₁₅	S ₁₄	S ₁₃	S ₁₂	S ₁₁	S ₁₀	S ₉	S ₈	S ₇	S ₆	S ₅	S ₄	S ₃	S ₂	S ₁	S ₀
Reserved				Test	PLL2 Synthesizer control					PLL2 Reference counter R ₂ divide ratio								Address		
				0	C ₂₄	C ₂₃	C ₂₂	C ₂₁	C ₂₀	R ₂₈	R ₂₇	R ₂₆	R ₂₅	R ₂₄	R ₂₃	R ₂₂	R ₂₁	R ₂₀	0	0
Res.	PLL2 Main counter M ₂ divide ratio									PLL2 Swallow counter A ₂ divide ratio				PLL2 Fractional counter F ₂ numerator value				Address		
	M ₂₈	M ₂₇	M ₂₆	M ₂₅	M ₂₄	M ₂₃	M ₂₂	M ₂₁	M ₂₀	A ₂₃	A ₂₂	A ₂₁	A ₂₀	F ₂₄	F ₂₃	F ₂₂	F ₂₁	F ₂₀	0	1
Res.	FlexiPower voltage regulation		PLL1 Synthesizer control					PLL1 Reference counter R ₁ divide ratio								Address				
	P ₂	Res.	P ₁	C ₁₄	C ₁₃	C ₁₂	C ₁₁	C ₁₀	R ₁₈	R ₁₇	R ₁₆	R ₁₅	R ₁₄	R ₁₃	R ₁₂	R ₁₁	R ₁₀	1	0	
PLL1 Main counter M ₁ divide ratio									PLL1 Swallow counter A ₁ divide ratio				PLL1 Fractional counter F ₁ numerator value				Address			
M ₁₈	M ₁₇	M ₁₆	M ₁₅	M ₁₄	M ₁₃	M ₁₂	M ₁₁	M ₁₀	A ₁₄	A ₁₃	A ₁₂	A ₁₁	A ₁₀	F ₁₄	F ₁₃	F ₁₂	F ₁₁	F ₁₀	1	1

↑ MSB (first in)

(last in) LSB ↑

Figure 8. Serial Interface Mode Timing Diagram

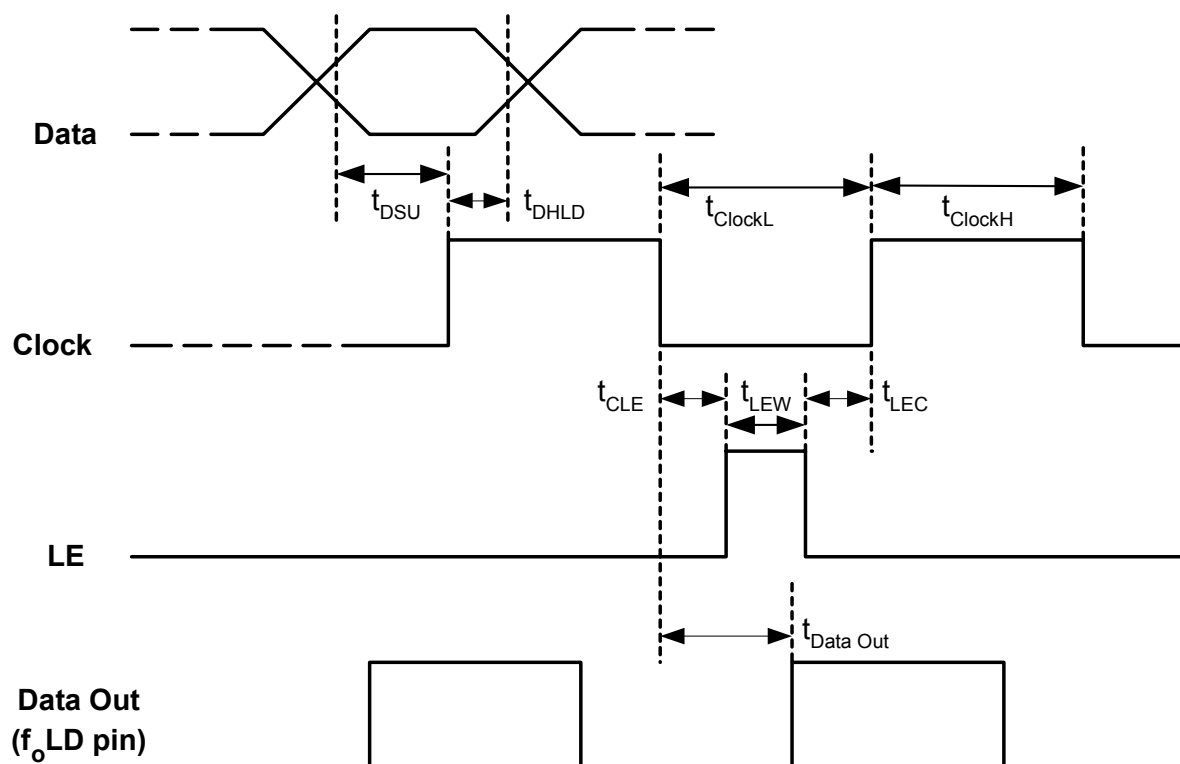

Programmable Divide Values (R1, R2, F1, F2, A1, A2, M1, M2)

Data is clocked into the 21-bit shift register, MSB first. When LE is asserted HIGH, data is latched into the registers addressed by the last two bits shifted into the 21-bit register, according to Table 7. For example, to program the PLL1 (RF) swallow counter, A1, the last two bits shifted into the register (S0, S1) would be (1,1). The 5-bit A1 counter would then be programmed according to Table 8. For normal operation, S16 of address (0,0) (the Test bit) must be programmed to 0 even if PLL2 (IF) is not used.

Table 8. PE3291 Counter Programming Example

Divide Value	MSB				LSB	Address	
	S ₁₁	S ₁₀	S ₉	S ₈	S ₇	S ₁	S ₀
	A ₁₄	A ₁₃	A ₁₂	A ₁₁	A ₁₀	1	1
0	0	0	0	0	0	1	1
1	0	0	0	0	1	1	1
2	0	0	0	1	0	1	1
-	-	-	-	-	-	1	1
31	1	1	1	1	1	1	1

Program Modes

Several modes of operation can be programmed with bits C₁₀ - C₁₄ and C₂₀ - C₂₄, including the phase detector polarity, charge pump high impedance, output of the foLD pin and power-down modes. The PE3291 modes of operation are shown on Table 9. The truth table for the foLD output is shown in Table 10.

Table 9. PE3291 Program Modes

S ₁₅	S ₁₄	S ₁₃	S ₁₂	S ₁₁	S ₁	S ₀
C ₂₄ See Table 10	C ₂₃ See Table 10	C ₂₂ 0 = PLL2 CP normal 1 = PLL2 CP High Z	C ₂₁ (Note 2) 0 = PLL2 Phase Detector inverted 1 = PLL2 Phase Detector normal	C ₂₀ (Note 1) 0 = PLL2 on 1 = PLL2 off	0	0
C ₁₄ See Table 10	C ₁₃ See Table 10	C ₁₂ 0 = PLL1 CP normal 1 = PLL1 CP High Z	C ₁₁ (Note 2) 0 = PLL1 Phase Detector inverted 1 = PLL1 Phase Detector normal	C ₁₀ (Note 1) 0 = PLL1 on 1 = PLL1 off	1	0

Note 1: The PLL1 power-down mode disables all of PLL1's components except the R₁ counter and the reference frequency input buffer, with CP1 (pin 3) and f_{in1} (pin 5) becoming high impedance. The power down of PLL2 has similar results with CP2 (pin 18) and f_{in2} (pin 16) becoming high impedance. Power down of both PLL1 and PLL2 further disables counters R₁ and R₂, the reference frequency input, and the foLD output, causing f_r (pin 8) and foLD (pin 10) to become high impedance. The Serial Control Interface remains active at all times.

Note 2: The C₁₁ and C₂₁ bits should be set according to the voltage versus frequency slope of the VCO as shown in Figure 9. This relationship presumes the use of a passive loop filter. If an inverting active loop filter is used the relationship is also inverted.

Figure 9. VCO Characteristics

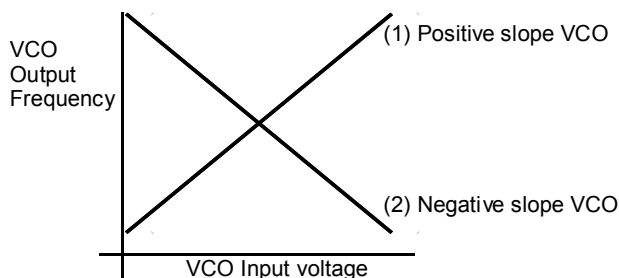

- When VCO1 (RF) slope is positive like (1), C₁₁ should be set HIGH.
- When VCO1 (RF) slope is negative like (2), C₁₁ should be set LOW.
- When VCO2 (IF) slope is positive like (1), C₂₁ should be set HIGH.
- When VCO2 (IF) slope is negative like (2), C₂₁ should be set LOW.

Table 10. f_oLD Programming Truth Table

X = don't care condition

f _o LD Output State	C ₁₄ (PLL1F ₀)	C ₁₃ (PLL1LD)	C ₂₄ (PLL2F ₀)	C ₂₃ (PLL2LD)
Disabled ¹	0	0	0	0
PLL 1 Lock detect ² (LD1)	0	1	0	0
PLL2 Lock detect ² (LD2)	0	0	0	1
PLL1 / PLL2 Lock detect ²	0	1	0	1
PLL1 Reference divider output (f _c 1)	1	X	0	0
PLL2 Reference divider output (f _c 2)	0	X	1	0
PLL1 Programmable divider output (f _p 1)	1	X	0	1
PLL2 Programmable divider output (f _p 2)	0	X	1	1
Serial data out	1	0	1	0
Reserved	1	0	1	1
Reserved	1	1	1	0
Counter reset ³	1	1	1	1

Note: 1. When the f_oLD is disabled the output is a CMOS LOW.

- Lock detect indicates when the VCO frequency is in "lock". When PLL1 is in lock and PLL1 lock detect is selected, the f_oLD pin will be HIGH with narrow pulses LOW. When PLL2 is in lock and PLL2 lock detect is selected, the f_oLD pin will be HIGH with narrow pulses LOW. When PLL1 / PLL2 lock detect is selected the f_oLD pin will be HIGH with narrow pulses LOW only when both PLL1 and PLL2 are in lock.
- The counter reset state when activated resets all counters. Upon removal of the reset, counters M, A, and F resume counting in close alignment with the R counter (the maximum error is one prescaler cycle). The reset bits can be activated to allow smooth acquisition upon powering up.

Programming the FlexiPower voltage

The PE3291 can be programmed to internally regulate down from the V_{DD} voltage to supply the FlexiPower voltage, as shown in Table 11. This is implemented by programming P₂, P₁ (S₁₈ & S₁₆ - address 1,0). When programmed with 0,0 external voltage supplies must be provided to the part at pins V_{DD1} and V_{DD2}. When using internal regulation, the FlexiPower supply pins should be left grounded.

Table 11. FlexiPower Voltage Regulation Programming

P ₂	P ₁	FlexiPower 1 voltage (RF PLL1)	FlexiPower 2 voltage (IF PLL2)
0	0	No regulation (FlexiPower externally provided)	
0	1	Low power	Low power
1	0	High speed	Low power
1	1	High speed	High speed

Phase Comparator Characteristics

PLL1 has the timing relationships shown below for f_c1 , f_p1 , LD1, UP1, and DOWN1. When $C_{11} = \text{HIGH}$, UP1 directs the internal PLL1 charge pump to source current and DOWN1 directs the PLL1 internal charge pump to sink current. If $C_{11} = \text{LOW}$, UP1 and DOWN1 are interchanged.

PLL2 has the timing relationships shown below for f_c2 , f_p2 , LD2, UP2, and DOWN2. When $C_{21} = \text{HIGH}$, UP2 directs the internal PLL2 charge pump to source current and DOWN2 directs the PLL2 internal charge pump to sink current. If $C_{21} = \text{LOW}$, UP2 and DOWN2 are interchanged.

Figure 10. Phase Comparator Timing Diagram

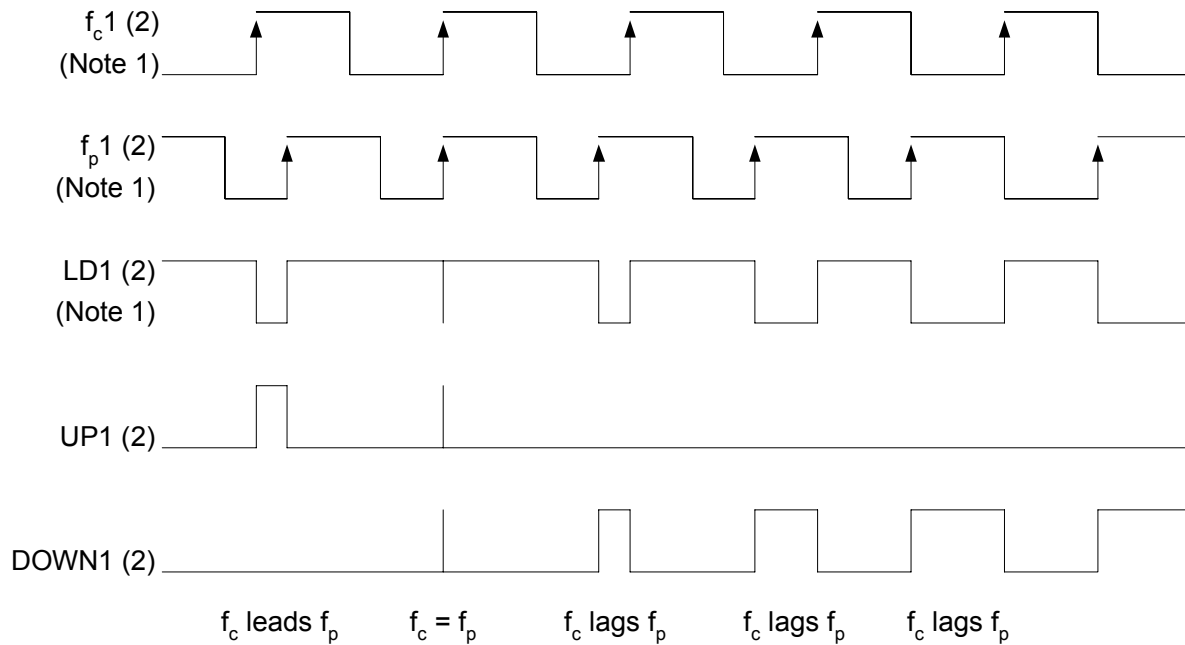

Note 1: $f_c1(2)$, $f_p1(2)$, and LD1(2) are accessible via the f_c LD pin per programming in Table 11.

Loop Filter

Second/Third Order Loops

Choosing the optimum loop filter for a design encompasses many trade offs. The rule of thumb for choosing the loop filter bandwidth is 10 percent of the step size. A second order loop (C_1 C_2 R_2 and C_4 C_5 R_5 in Figure 11 omitting C_3 R_3 C_6 and R_6) will provide the least amount of components and the fastest lock times. If lock time is an issue, one might try opening up the loop filter, although if it is too wide, instability will dominate and worsen lock time. If lock time is not an issue, a narrower second order filter will minimize residual FM without requiring additional components.

Third Order loop filters (C_1 C_2 R_2 C_3 R_3 and C_4 C_5 R_5 C_6 R_6 in Figure 11) provide a good compromise between lock time and residual FM. We have found using a third order loop with 20 dB of rejection at the step size will halve the Residual FM as measured with a similar second order loop, with minimum effect on lock time.

Loop Filter Bandwidth Design Considerations

As part of the spur compensation circuitry, the PE329x series PLLs contain capacitors to ground internal to the charge pump. PLL1 contains a 50 pF capacitor and PLL2 contains a 100 pF capacitor. To ensure accurate loop filter calculations, it is critical that the calculated value of the first shunt capacitor (C_1 & C_4 in Figure 11) be at least 100 pF for PLL1 and 200 pF for PLL2. With this requirement satisfied, the remaining loop components can be calculated.

For a stable loop, it is also important that the loop bandwidth be less than or equal to one tenth of the step size.

Digital Control Lines

Control Line Noise

We have noticed frequency jitter during programming when a low impedance, such as a capacitor to ground, is placed next to any control line pin (clock, data, and load enable). The use of a 51 k ohm resistor in series with the control line will eliminate the problem with no effect to programming time.

Enable Line Voltage

The PE329x series PLLs use a level sensitive load enable. Therefore the digital controller must provide an active low to the part at all times except when the data is to be loaded into the shift register. If the PLL controller does not hold the voltage low, a high impedance resistor to ground should be added to the enable line to ensure stable operation.

5 Volt Operation:

The PE329x series PLLs are not capable of accepting control voltages greater than 3.3 volts. Interface to 5 volt controllers requires the addition of resistor dividers to comply with the 3.3 volt maximum operation voltage.

Figure 11. Application Example

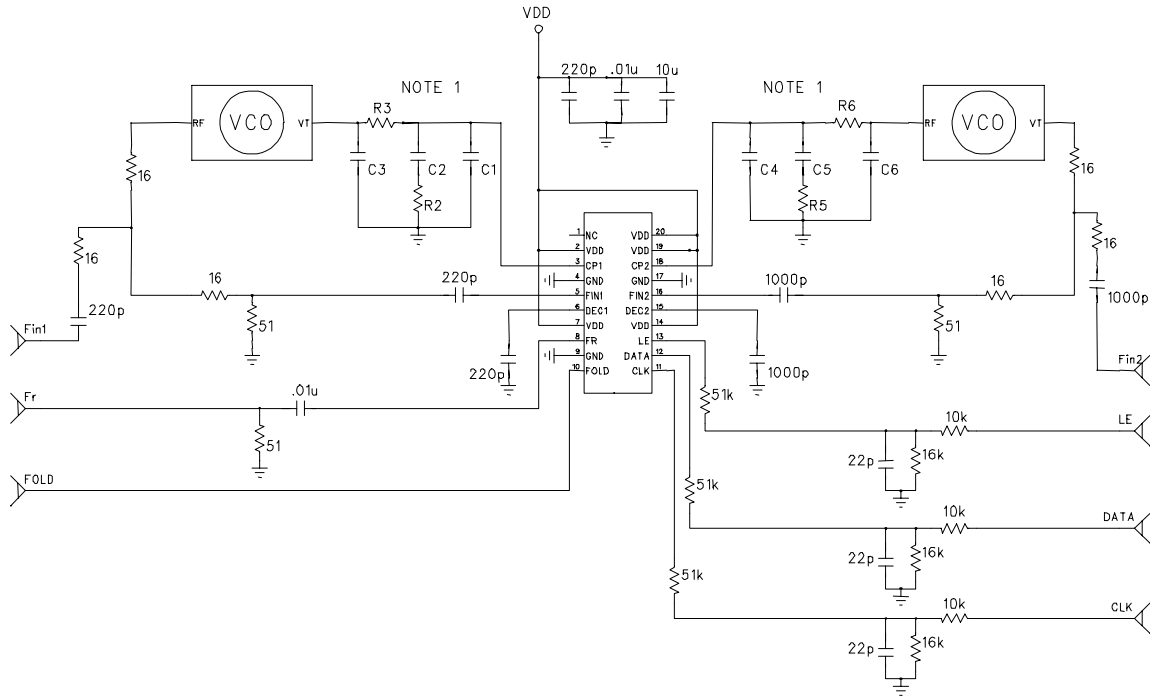

Note 1: For optimum fractional spur and lock-time performance C_2 and C_5 should be polyester (or polypropylene). In addition, the loop filter components must be free from contamination. Contamination will result in poor spur performance. For accurate loop bandwidth, C_1 must be greater than or equal to 100 pF, and C_4 must be greater than or equal to 200 pF.

Figure 12. Package Drawing
20-lead TSSOP (JEDEC MO-153-AC)

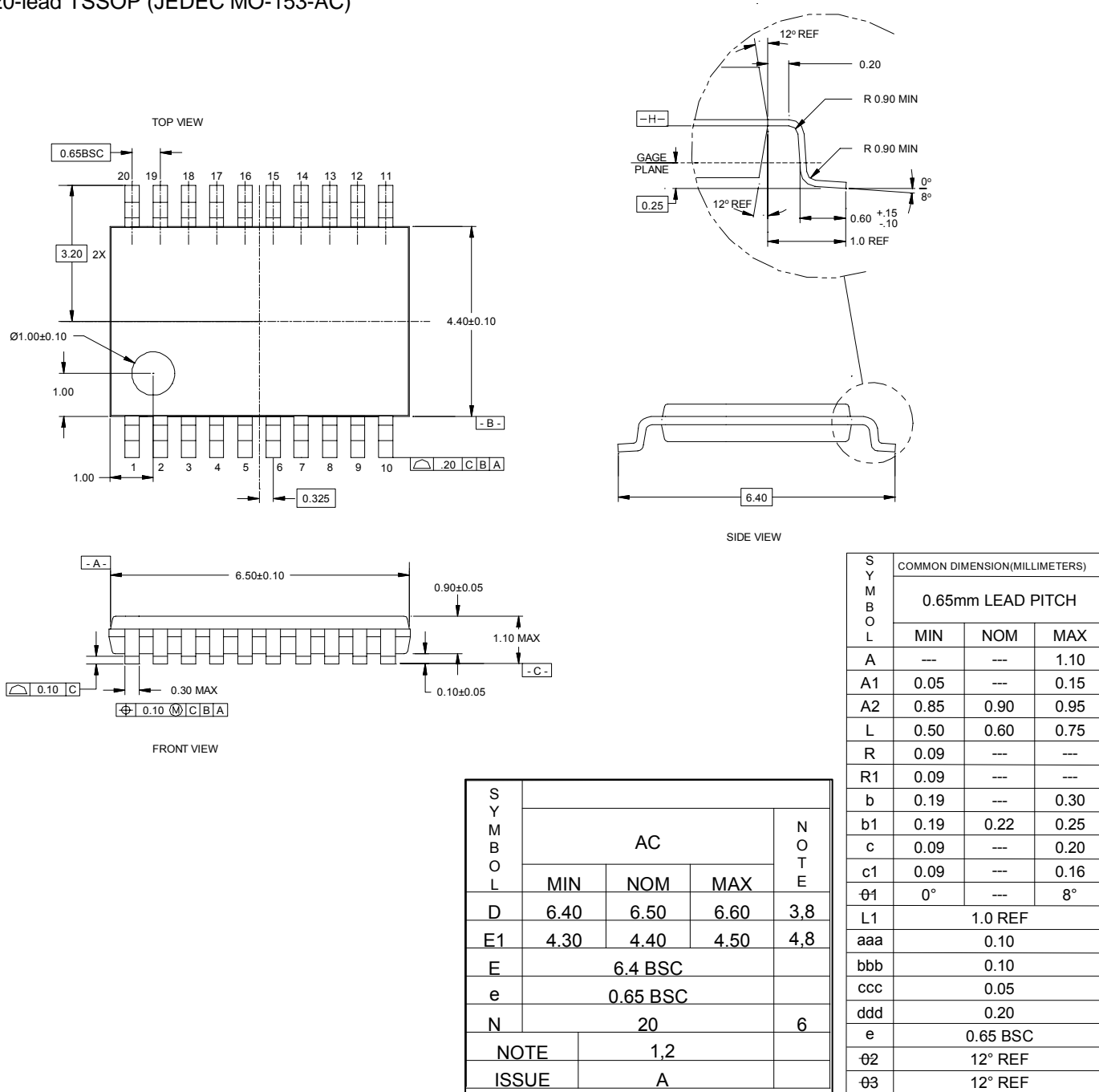

Table 12. Ordering Information

Order Code	Part Marking	Description	Package	Shipping Method
3291-11	PE3291	PE3291-20TSSOP-74A	20-lead TSSOP	74 units / Tube
3291-12	PE3291	PE3291-20TSSOP-2000C	20-lead TSSOP	2000 unit / T&R
3291-00	PE3291EK	PE3291-20TSSOP-Eval Kit	Evaluation Kit	1 / Box

Sales Offices

The Americas

Peregrine Semiconductor Corporation

9450 Carroll Park Drive
San Diego, CA 92121
Tel 858-731-9400
Fax 858-731-9499

Europe

Peregrine Semiconductor Europe

Bâtiment Maine
13-15 rue des Quatre Vents
F- 92380 Garches, France
Tel: +33-1-47-41-91-73
Fax : +33-1-47-41-91-73

Space and Defense Products

Americas:

Tel: 505-881-0438
Fax: 505-881-0443

Europe, Asia Pacific:

180 Rue Jean de Guiramand
13852 Aix-En-Provence cedex 3, France
Tel: +33(0) 4 4239 3361
Fax: +33(0) 4 4239 7227

For a list of representatives in your area, please refer to our Web site at: www.psemi.com

Data Sheet Identification

Advance Information

The product is in a formative or design stage. The data sheet contains design target specifications for product development. Specifications and features may change in any manner without notice.

Preliminary Specification

The data sheet contains preliminary data. Additional data may be added at a later date. Peregrine reserves the right to change specifications at any time without notice in order to supply the best possible product.

Product Specification

The data sheet contains final data. In the event Peregrine decides to change the specifications, Peregrine will notify customers of the intended changes by issuing a DCN (Document Change Notice).

North Asia Pacific

Peregrine Semiconductor K.K.

5A-5, 5F Imperial Tower
1-1-1 Uchisaiwaicho, Chiyoda-ku
Tokyo 100-0011 Japan
Tel: +81-3-3502-5211
Fax: +81-3-3502-5213

Peregrine Semiconductor, Korea

#B-2402, Kolon Tripolis, #210
Geumgok-dong, Bundang-gu, Seongnam-si,
Gyeonggi-do, 463-480 S. Korea
Tel: +82-31-728-4300
Fax: +82-31-728-4305

South Asia Pacific

Peregrine Semiconductor, China

Shanghai, 200040, P.R. China
Tel: +86-21-5836-8276
Fax: +86-21-5836-7652

The information in this data sheet is believed to be reliable. However, Peregrine assumes no liability for the use of this information. Use shall be entirely at the user's own risk.

No patent rights or licenses to any circuits described in this data sheet are implied or granted to any third party.

Peregrine's products are not designed or intended for use in devices or systems intended for surgical implant, or in other applications intended to support or sustain life, or in any application in which the failure of the Peregrine product could create a situation in which personal injury or death might occur. Peregrine assumes no liability for damages, including consequential or incidental damages, arising out of the use of its products in such applications.

The Peregrine name, logo, and UTSi are registered trademarks and UltraCMOS and HaRP are trademarks of Peregrine Semiconductor Corp.