

# MC34064, MC33064, NCV33064

## Undervoltage Sensing Circuit

The MC34064 is an undervoltage sensing circuit specifically designed for use as a reset controller in microprocessor-based systems. It offers the designer an economical solution for low voltage detection with a single external resistor. The MC34064 features a trimmed-in-package bandgap reference, and a comparator with precise thresholds and built-in hysteresis to prevent erratic reset operation. The open collector reset output is capable of sinking in excess of 10 mA, and operation is guaranteed down to 1.0 V input with low standby current. The MC devices are packaged in 3-pin TO-92, micro size TSOP-5, 8-pin SOIC-8 and Micro8™ surface mount packages. The NCV device is packaged in SOIC-8 and TO-92.

Applications include direct monitoring of the 5.0 V MPU/logic power supply used in appliance, automotive, consumer and industrial equipment.

### Features

- Trimmed-In-Package Temperature Compensated Reference
- Comparator Threshold of 4.6 V at 25°C
- Precise Comparator Thresholds Guaranteed Over Temperature
- Comparator Hysteresis Prevents Erratic Reset
- Reset Output Capable of Sinking in Excess of 10 mA
- Internal Clamp Diode for Discharging Delay Capacitor
- Guaranteed Reset Operation with 1.0 V Input
- Low Standby Current
- Economical TO-92, TSOP-5, SOIC-8 and Micro8 Surface Mount Packages
- Pb-Free Packages are Available
- NCV Prefix for Automotive and Other Applications Requiring Site and Control Changes

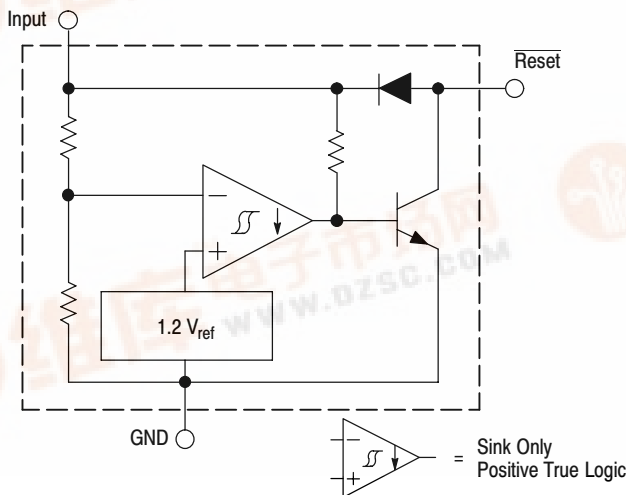

This device contains 21 active transistors.

Figure 1. Representative Block Diagram



ON Semiconductor®

<http://onsemi.com>



SOIC-8  
D SUFFIX  
CASE 751

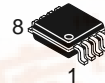

Micro8  
DM SUFFIX  
CASE 846A



TSOP-5  
SN SUFFIX  
CASE 483

Pin 1. Ground  
2. Input  
3. Reset  
4. NC  
5. NC

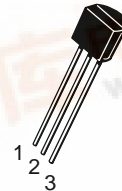

TO-92  
P SUFFIX  
CASE 29

Pin 1. Reset  
2. Input  
3. Ground

### PIN CONNECTIONS

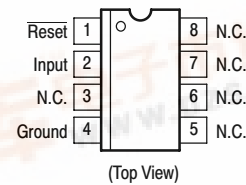

### ORDERING INFORMATION

See detailed ordering and shipping information in the package dimensions section on page 6 of this data sheet.

### DEVICE MARKING INFORMATION

See general marking information in the device marking section on page 7 of this data sheet.



# MC34064, MC33064, NCV33064

## MAXIMUM RATINGS

Rating	Symbol	Value	Unit
Power Input Supply Voltage	$V_{in}$	-1.0 to 10	V
Reset Output Voltage	$V_O$	10	V
Reset Output Sink Current (Note 2)	$I_{Sink}$	Internally Limited	mA
Clamp Diode Forward Current, Reset to Input Pin (Note 2)	$I_F$	100	mA
Power Dissipation and Thermal Characteristics			
P Suffix, Plastic Package			
Maximum Power Dissipation @ $T_A = 25^\circ\text{C}$	$P_D$	625	mW
Thermal Resistance, Junction-to-Air	$R_{\theta JA}$	200	$^\circ\text{C/W}$
D Suffix, Plastic Package			
Maximum Power Dissipation @ $T_A = 25^\circ\text{C}$	$P_D$	625	mW
Thermal Resistance, Junction-to-Air	$R_{\theta JA}$	200	$^\circ\text{C/W}$
DM Suffix, Plastic Package			
Maximum Power Dissipation @ $T_A = 25^\circ\text{C}$	$P_D$	520	mW
Thermal Resistance, Junction-to-Air	$R_{\theta JA}$	240	$^\circ\text{C/W}$
Operating Junction Temperature	$T_J$	+150	$^\circ\text{C}$
Operating Ambient Temperature	$T_A$		$^\circ\text{C}$
MC34064		0 to +70	
MC33064		-40 to +85	
NCV33064		-40 to +125	
Storage Temperature Range	$T_{stg}$	-65 to +150	$^\circ\text{C}$

Maximum ratings are those values beyond which device damage can occur. Maximum ratings applied to the device are individual stress limit values (not normal operating conditions) and are not valid simultaneously. If these limits are exceeded, device functional operation is not implied, damage may occur and reliability may be affected.

- ESD data available upon request.

**ELECTRICAL CHARACTERISTICS** (For typical values  $T_A = 25^\circ\text{C}$ , for min/max values  $T_A$  is the operating ambient temperature range that applies [Notes 3 and 4] unless otherwise noted.)

Characteristics	Symbol	Min	Typ	Max	Unit
-----------------	--------	-----	-----	-----	------

### COMPARATOR

Threshold Voltage					V
High State Output ( $V_{in}$ Increasing)	$V_{IH}$	4.5	4.61	4.7	
Low State Output ( $V_{in}$ Decreasing)	$V_{IL}$	4.5	4.59	4.7	
Hysteresis	$V_H$	0.01	0.02	0.05	

### RESET OUTPUT

Output Sink Saturation	$V_{OL}$				V
( $V_{in} = 4.0\text{ V}$ , $I_{Sink} = 8.0\text{ mA}$ )		-	0.46	1.0	
( $V_{in} = 4.0\text{ V}$ , $I_{Sink} = 2.0\text{ mA}$ )		-	0.15	0.4	
( $V_{in} = 1.0\text{ V}$ , $I_{Sink} = 0.1\text{ mA}$ )		-	-	0.1	
Output Sink Current ( $V_{in}$ , $\overline{\text{Reset}} = 4.0\text{ V}$ )	$I_{Sink}$	10	27	60	mA
Output Off-State Leakage ( $V_{in}$ , $\overline{\text{Reset}} = 5.0\text{ V}$ )	$I_{OH}$	-	0.02	0.5	$\mu\text{A}$
Clamp Diode Forward Voltage, Reset to Input Pin ( $I_F = 10\text{ mA}$ )	$V_F$	0.6	0.9	1.2	V

### TOTAL DEVICE

Operating Input Voltage Range	$V_{in}$	1.0 to 6.5	-	-	V
Quiescent Input Current ( $V_{in} = 5.0\text{ V}$ )	$I_{in}$	-	390	500	$\mu\text{A}$

- Maximum package power dissipation limits must be observed.
- Low duty cycle pulse techniques are used during test to maintain junction temperature as close to ambient as possible.
- $T_{low} = 0^\circ\text{C}$  for MC34064                       $T_{high} = +70^\circ\text{C}$  for MC34064  
            $-40^\circ\text{C}$  for MC33064                       $+85^\circ\text{C}$  for MC33064  
            $-40^\circ\text{C}$  for NCV33064                       $+125^\circ\text{C}$  for NCV33064
- NCV prefix is for automotive and other applications requiring site and change control.

# MC34064, MC33064, NCV33064

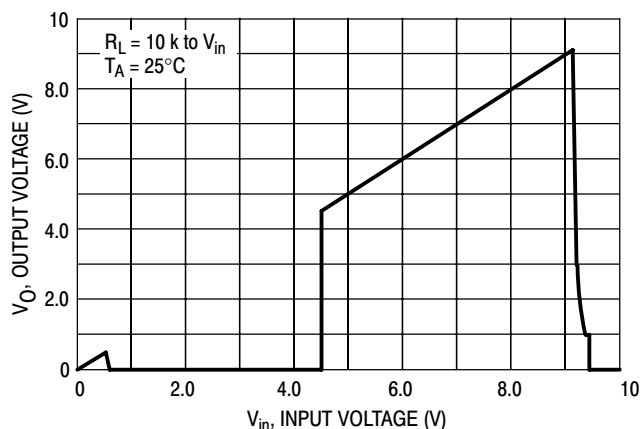

Figure 2.  $\overline{\text{Reset}}$  Output Voltage versus Input Voltage

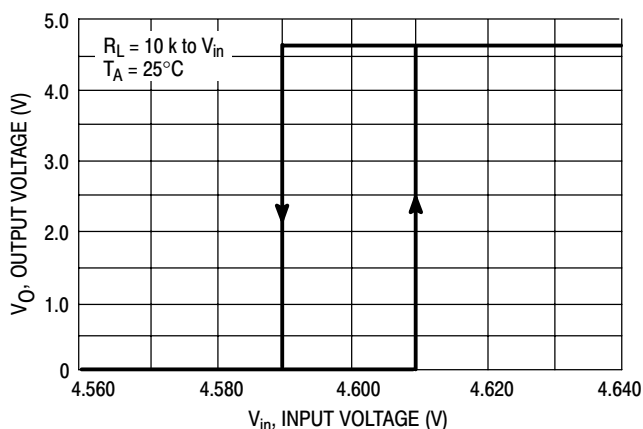

Figure 3.  $\overline{\text{Reset}}$  Output Voltage versus Input Voltage

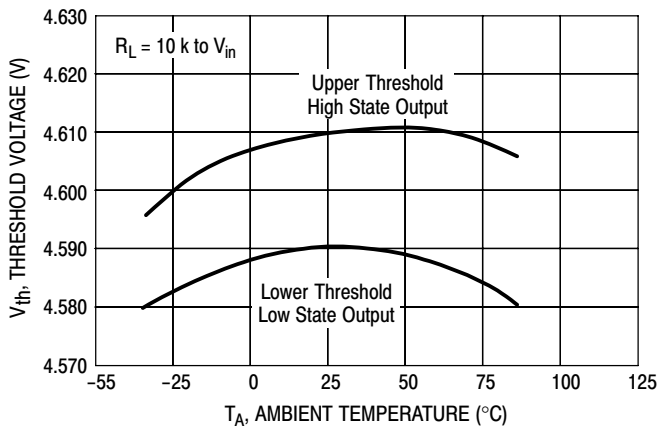

Figure 4. Comparator Threshold Voltage versus Temperature

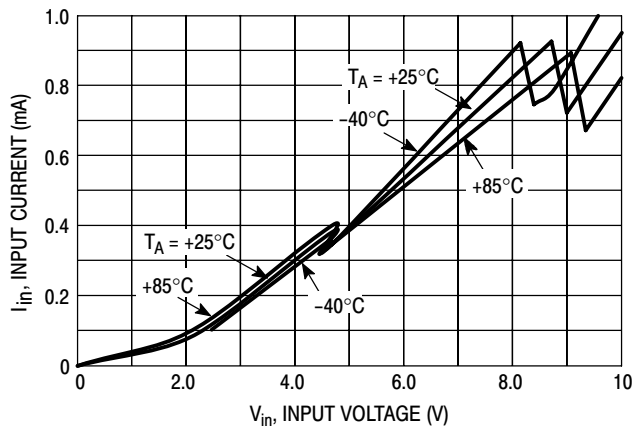

Figure 5. Input Current versus Input Voltage

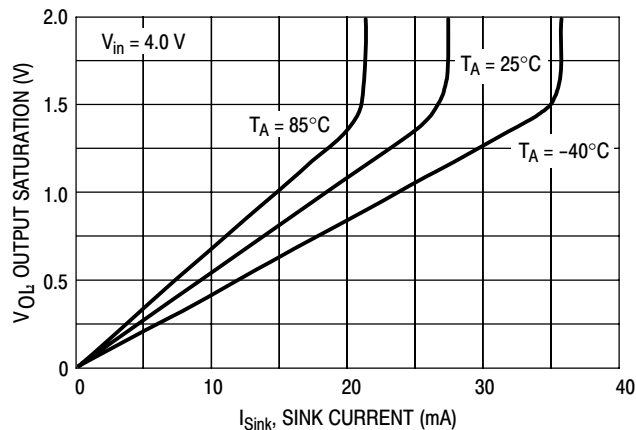

Figure 6.  $\overline{\text{Reset}}$  Output Saturation versus Sink Current

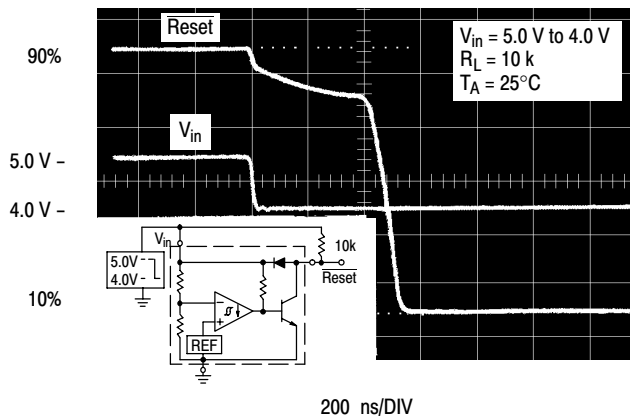

Figure 7.  $\overline{\text{Reset}}$  Delay Time

# MC34064, MC33064, NCV33064

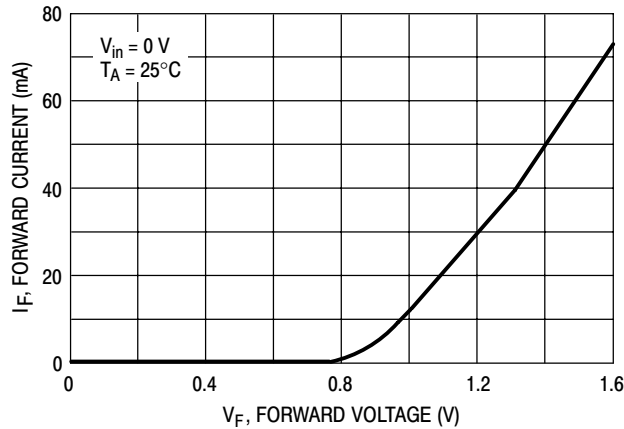

Figure 8. Clamp Diode Forward Current versus Voltage

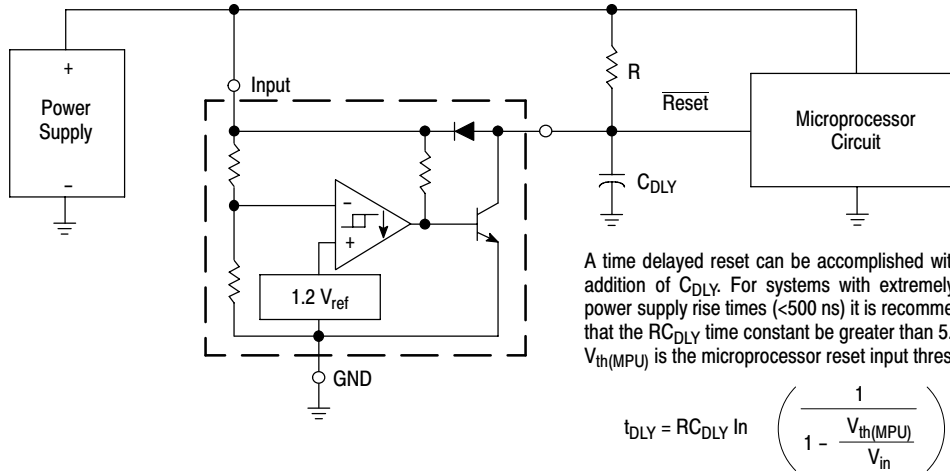
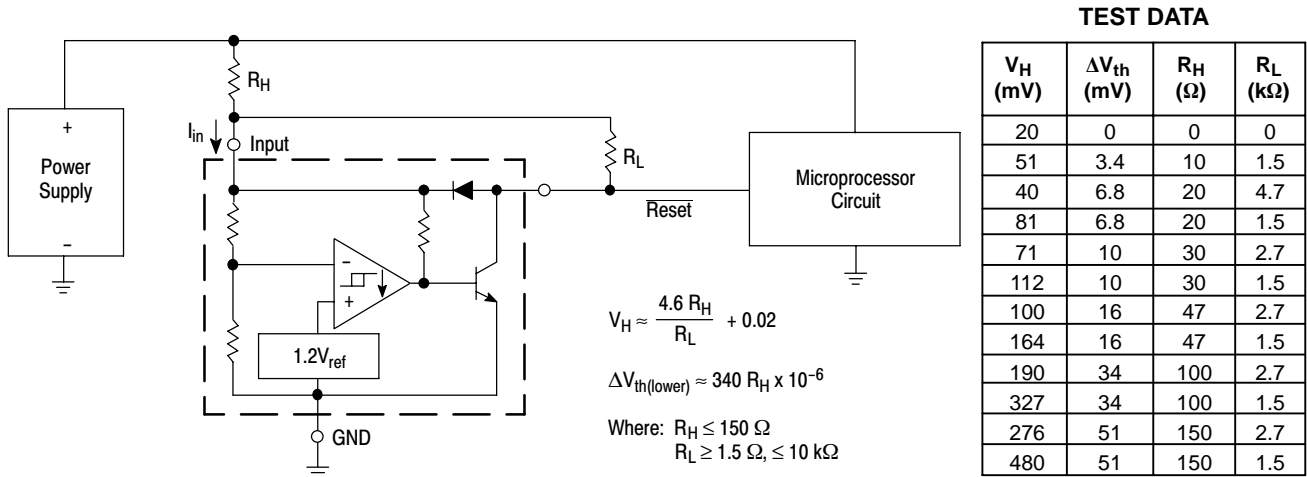

Figure 9. Low Voltage Microprocessor Reset



Comparator hysteresis can be increased with the addition of resistor  $R_H$ . The hysteresis equation has been simplified and does not account for the change of input current  $I_{in}$  as  $V_{CC}$  crosses the comparator threshold (Figure 4). An increase of the lower threshold  $\Delta V_{th(lower)}$  will be observed due to  $I_{in}$  which is typically  $340 \mu A$  at  $4.59 \text{ V}$ . The equations are accurate to  $\pm 10\%$  with  $R_H$  less than  $150 \Omega$  and  $R_L$  between  $1.5 \text{ k}\Omega$  and  $10 \text{ k}\Omega$ .

Figure 10. Low Voltage Microprocessor Reset with Additional Hysteresis

# MC34064, MC33064, NCV33064

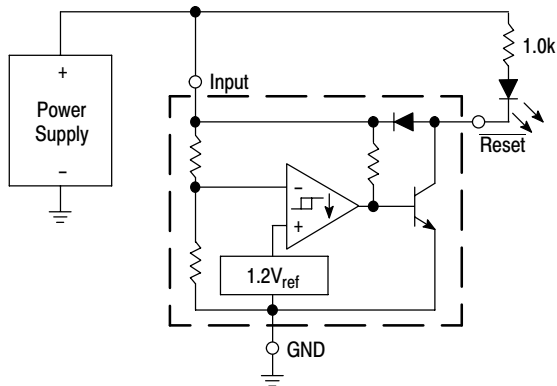

Figure 11. Voltage Monitor

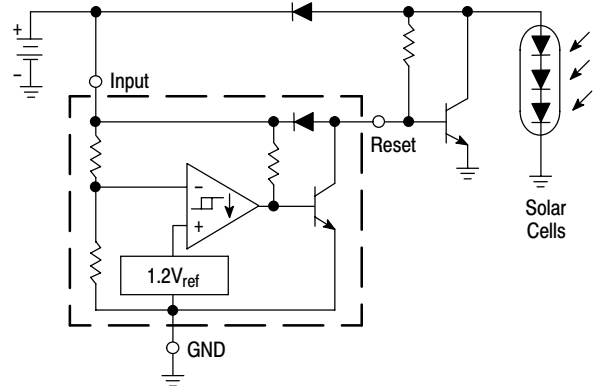
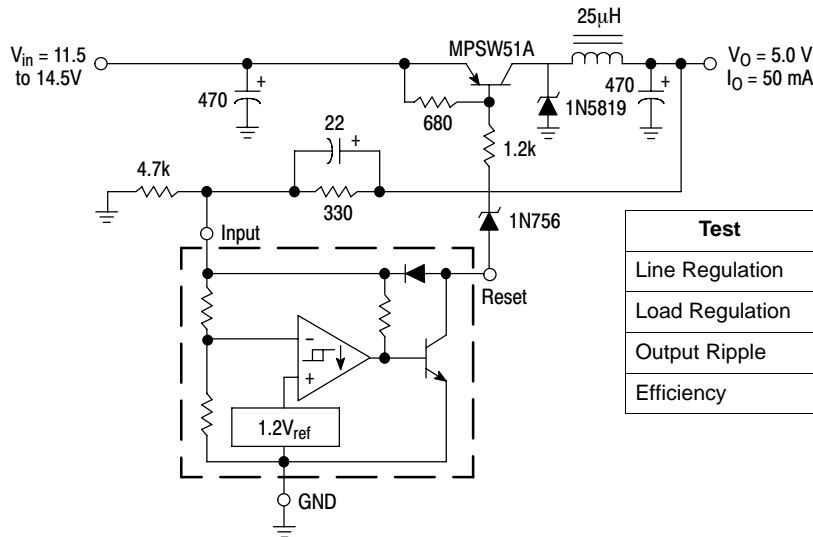
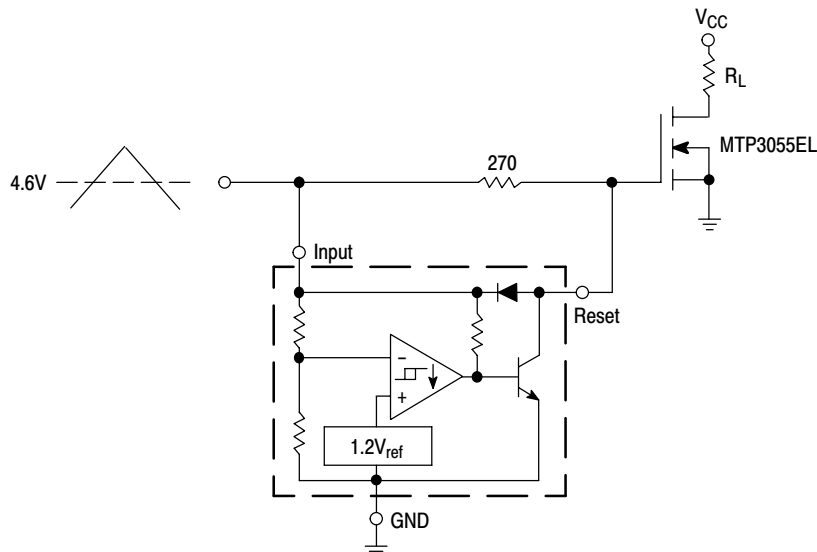

Figure 12. Solar Powered Battery Charger



Test	Conditions	Results
Line Regulation	$V_{in} = 11.5 \text{ V to } 14.5 \text{ V}, I_O = 50 \text{ mA}$	35 mV
Load Regulation	$V_{in} = 12.6 \text{ V}, I_O = 0 \text{ mA to } 50 \text{ mA}$	12 mV
Output Ripple	$V_{in} = 12.6 \text{ V}, I_O = 50 \text{ mA}$	60 mVpp
Efficiency	$V_{in} = 12.6 \text{ V}, I_O = 50 \text{ mA}$	77%

Figure 13. Low Power Switching Regulator



Overheating of the logic level power MOSFET due to insufficient gate voltage can be prevented with the above circuit. When the input signal is below the 4.6 V threshold of the MC34064, its output grounds the gate of the L<sup>2</sup> MOSFET.

Figure 14. MOSFET Low Voltage Gate Drive Protection

## MC34064, MC33064, NCV33064

### ORDERING INFORMATION

Device	Operating Temperature Range	Package	Shipping <sup>†</sup>
MC34064D-005	T <sub>A</sub> = 0°C to +70°C	SOIC-8	98 Units / Rail
MC34064D-005G		SOIC-8 (Pb-Free)	
MC34064D-5R2		SOIC-8	2500 Units/ Tape & Reel
MC34064D-5R2G		SOIC-8 (Pb-Free)	
MC34064DM-5R2		Micro8	4000 Units / Tape & Reel
MC34064DM-5R2G		Micro8 (Pb-Free)	
MC34064P-005		TO-92	2000 Units / Bag
MC34064P-005G		TO-92 (Pb-Free)	
MC34064P-5RA		TO-92	2000 Units / Tape & Reel
MC34064P-5RAG		TO-92 (Pb-Free)	
MC34064P-5RP		TO-92	2000 Units / Ammo Pack
MC34064P-5RPG		TO-92 (Pb-Free)	
MC34064P-5RM		TO-92	
MC34064P-5RMG		TO-92 (Pb-Free)	
MC34064SN-5T1		TSOP-5	3000 Units / Tape & Reel
MC34064SN-5T1G		TSOP-5 (Pb-Free)	
MC33064D-005		T <sub>J</sub> = -40°C to +85°C	SOIC-8
MC33064D-005G	SOIC-8 (Pb-Free)		
MC33064D-5R2	SOIC-8		2500 Units / Tape & Reel
MC33064D-5R2G	SOIC-8 (Pb-Free)		
MC33064DM-5R2	Micro8		4000 Units / Tape & Reel
MC33064DM-5R2G	Micro8 (Pb-Free)		
MC33064P-005	TO-92		2000 Units / Bag
MC33064P-005G	TO-92 (Pb-Free)		
MC33064P-5RA	TO-92		2000 Units / Tape & Reel
MC33064P-5RAG	TO-92 (Pb-Free)		
MC33064P-5RP	TO-92		2000 Units / Ammo Pack
MC33064P-5RPG	TO-92 (Pb-Free)		
MC33064SN-5T1	TSOP-5		3000 Units / Tape & Reel
MC33064SN-5T1G	TSOP-5 (Pb-Free)		

<sup>†</sup>For information on tape and reel specifications, including part orientation and tape sizes, please refer to our Tape and Reel Packaging Specifications Brochure, BRD8011/D.

\*NCV33064: T<sub>low</sub> = -40°C, T<sub>high</sub> = +125°C. Guaranteed by design. NCV prefix is for automotive and other applications requiring site and change control.

# MC34064, MC33064, NCV33064

## ORDERING INFORMATION

Device	Operating Temperature Range	Package	Shipping <sup>†</sup>
NCV33064D-5R2*	T <sub>A</sub> = -40°C to +125°C	SOIC-8	2500 Units / Tape & Reel
NCV33064D-5R2G*		SOIC-8 (Pb-Free)	
NCV33064P-5RA*		TO-92	2000 Units / Tape & Reel
NCV33064P-5RAG*		TO-92 (Pb-Free)	
NCV33064P-5RP*		TO-92	2000 Units / Ammo Pack
NCV33064P-5RPG*		TO-92 (Pb-Free)	
NCV33064DM-5R2*		Micro8	4000 Units / Tape & Reel
NCV33064DM-5R2G*		Micro8 (Pb-Free)	

<sup>†</sup>For information on tape and reel specifications, including part orientation and tape sizes, please refer to our Tape and Reel Packaging Specifications Brochure, BRD8011/D.

\*NCV33064: T<sub>low</sub> = -40°C, T<sub>high</sub> = +125°C. Guaranteed by design. NCV prefix is for automotive and other applications requiring site and change control.

## MARKING DIAGRAMS

**SOIC-8**  
**D SUFFIX**  
**CASE 751**

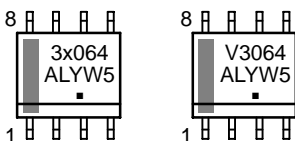

**Micro8**  
**DM SUFFIX**  
**CASE 846A**

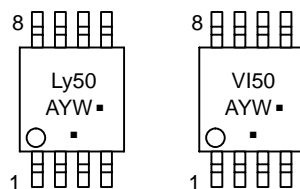

**TO-92**  
**P SUFFIX**  
**CASE 29**

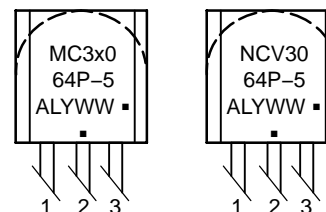

**TSOP-5**  
**SN SUFFIX**  
**CASE 483**

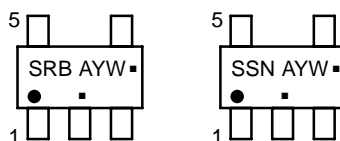

**MC34064**

**MC33064**

- x = 3 or 4
- y = C or I
- A = Assembly Location
- L = Wafer Lot
- Y = Year
- W, WW = Work Week
- = Pb-Free Package

(Note: Microdot may be in either location)

# MC34064, MC33064, NCV33064

## PACKAGE DIMENSIONS

SOIC-8  
D SUFFIX  
PLASTIC PACKAGE  
CASE 751-07  
ISSUE AG

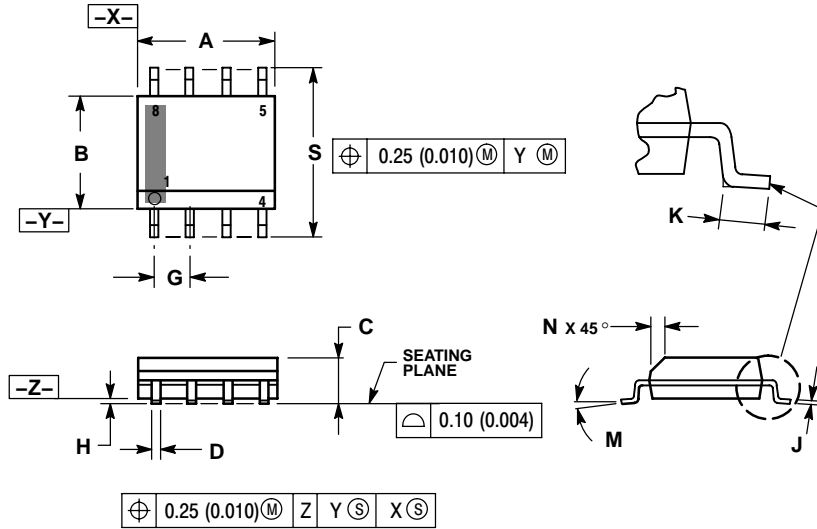

### NOTES:

1. DIMENSIONING AND TOLERANCING PER ANSI Y14.5M, 1982.
2. CONTROLLING DIMENSION: MILLIMETER.
3. DIMENSION A AND B DO NOT INCLUDE MOLD PROTRUSION.
4. MAXIMUM MOLD PROTRUSION 0.15 (0.006) PER SIDE.
5. DIMENSION D DOES NOT INCLUDE DAMBAR PROTRUSION. ALLOWABLE DAMBAR PROTRUSION SHALL BE 0.127 (0.005) TOTAL IN EXCESS OF THE D DIMENSION AT MAXIMUM MATERIAL CONDITION.
6. 751-01 THRU 751-06 ARE OBSOLETE. NEW STANDARD IS 751-07.

DIM	MILLIMETERS		INCHES	
	MIN	MAX	MIN	MAX
A	4.80	5.00	0.189	0.197
B	3.80	4.00	0.150	0.157
C	1.35	1.75	0.053	0.069
D	0.33	0.51	0.013	0.020
G	1.27 BSC		0.050 BSC	
H	0.10	0.25	0.004	0.010
J	0.19	0.25	0.007	0.010
K	0.40	1.27	0.016	0.050
M	0°	8°	0°	8°
N	0.25	0.50	0.010	0.020
S	5.80	6.20	0.228	0.244

### SOLDERING FOOTPRINT\*

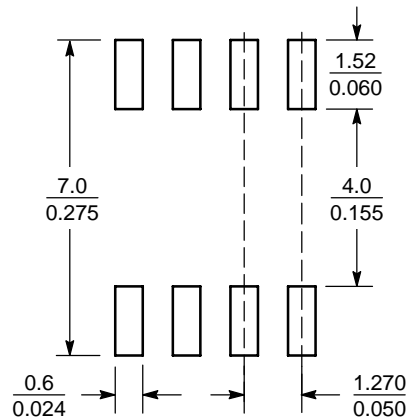

SCALE 6:1  $\left(\frac{\text{mm}}{\text{inches}}\right)$

\*For additional information on our Pb-Free strategy and soldering details, please download the ON Semiconductor Soldering and Mounting Techniques Reference Manual, SOLDERRM/D.



# MC34064, MC33064, NCV33064

## PACKAGE DIMENSIONS

**Micro8**  
**DM SUFFIX**  
 PLASTIC PACKAGE  
 CASE 846A-02  
 ISSUE F

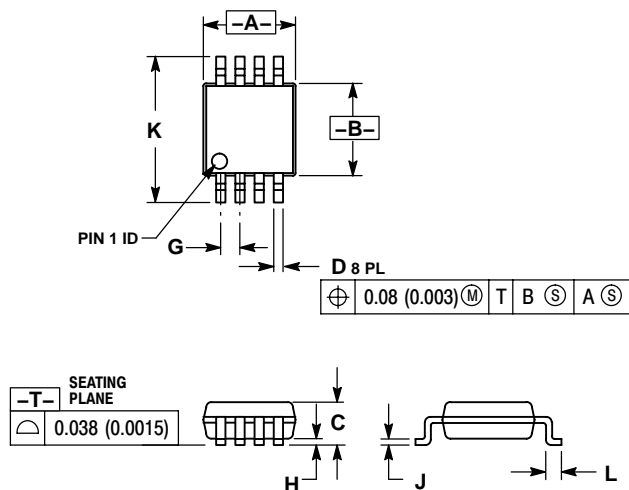

- NOTES:
1. DIMENSIONING AND TOLERANCING PER ANSI Y14.5M, 1982.
  2. CONTROLLING DIMENSION: MILLIMETER.
  3. DIMENSION A DOES NOT INCLUDE MOLD FLASH, PROTRUSIONS OR GATE BURRS. MOLD FLASH, PROTRUSIONS OR GATE BURRS SHALL NOT EXCEED 0.15 (0.006) PER SIDE.
  4. DIMENSION B DOES NOT INCLUDE INTERLEAD FLASH OR PROTRUSION. INTERLEAD FLASH OR PROTRUSION SHALL NOT EXCEED 0.25 (0.010) PER SIDE.
  5. 846A-01 OBSOLETE, NEW STANDARD 846A-02.

DIM	MILLIMETERS		INCHES	
	MIN	MAX	MIN	MAX
A	2.90	3.10	0.114	0.122
B	2.90	3.10	0.114	0.122
C	---	1.10	---	0.043
D	0.25	0.40	0.010	0.016
G	0.65 BSC		0.026 BSC	
H	0.05	0.15	0.002	0.006
J	0.13	0.23	0.005	0.009
K	4.75	5.05	0.187	0.199
L	0.40	0.70	0.016	0.028

### SOLDERING FOOTPRINT\*

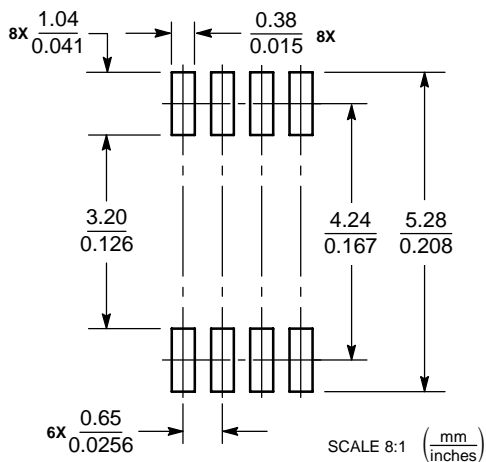

\*For additional information on our Pb-Free strategy and soldering details, please download the ON Semiconductor Soldering and Mounting Techniques Reference Manual, SOLDERRM/D.

# MC34064, MC33064, NCV33064

## PACKAGE DIMENSIONS

**TSOP-5**  
**SN SUFFIX**  
 PLASTIC PACKAGE  
 CASE 483-02  
 ISSUE E

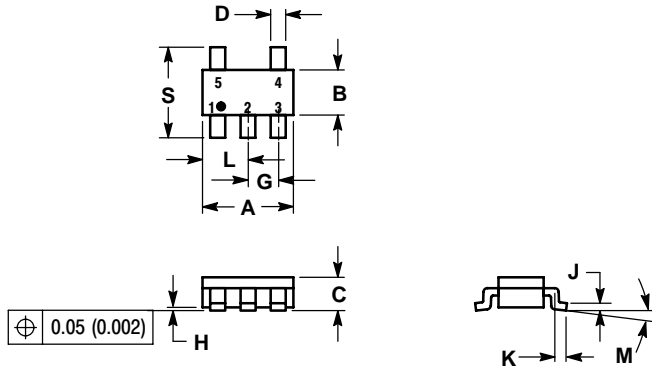

**NOTES:**

1. DIMENSIONING AND TOLERANCING PER ANSI Y14.5M, 1982.
2. CONTROLLING DIMENSION: MILLIMETER.
3. MAXIMUM LEAD THICKNESS INCLUDES LEAD FINISH THICKNESS. MINIMUM LEAD THICKNESS IS THE MINIMUM THICKNESS OF BASE MATERIAL.
4. A AND B DIMENSIONS DO NOT INCLUDE MOLD FLASH, PROTRUSIONS, OR GATE BURRS.

DIM	MILLIMETERS		INCHES	
	MIN	MAX	MIN	MAX
A	2.90	3.10	0.1142	0.1220
B	1.30	1.70	0.0512	0.0669
C	0.90	1.10	0.0354	0.0433
D	0.25	0.50	0.0098	0.0197
G	0.85	1.05	0.0335	0.0413
H	0.013	0.100	0.0005	0.0040
J	0.10	0.26	0.0040	0.0102
K	0.20	0.60	0.0079	0.0236
L	1.25	1.55	0.0493	0.0610
M	0°	10°	0°	10°
S	2.50	3.00	0.0985	0.1181

### SOLDERING FOOTPRINT\*

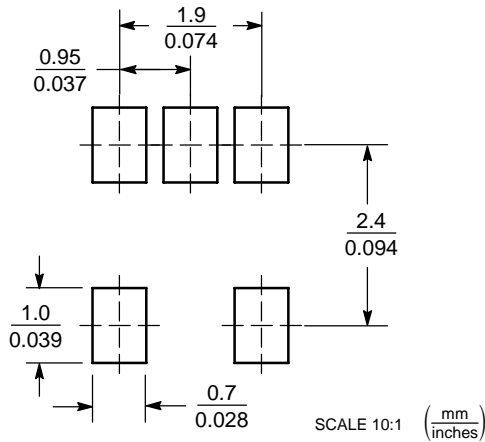

\*For additional information on our Pb-Free strategy and soldering details, please download the ON Semiconductor Soldering and Mounting Techniques Reference Manual, SOLDERRM/D.

# MC34064, MC33064, NCV33064

## PACKAGE DIMENSIONS

TO-92  
P SUFFIX  
PLASTIC PACKAGE  
CASE 29-11  
ISSUE AL

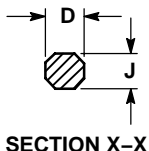
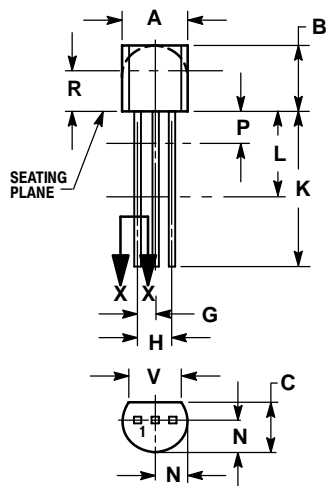

### NOTES:

1. DIMENSIONING AND TOLERANCING PER ANSI Y14.5M, 1982.
2. CONTROLLING DIMENSION: INCH.
3. CONTOUR OF PACKAGE BEYOND DIMENSION R IS UNCONTROLLED.
4. LEAD DIMENSION IS UNCONTROLLED IN P AND BEYOND DIMENSION K MINIMUM.

DIM	INCHES		MILLIMETERS	
	MIN	MAX	MIN	MAX
A	0.175	0.205	4.45	5.20
B	0.170	0.210	4.32	5.33
C	0.125	0.165	3.18	4.19
D	0.016	0.021	0.407	0.533
G	0.045	0.055	1.15	1.39
H	0.095	0.105	2.42	2.66
J	0.015	0.020	0.39	0.50
K	0.500	---	12.70	---
L	0.250	---	6.35	---
N	0.080	0.105	2.04	2.66
P	---	0.100	---	2.54
R	0.115	---	2.93	---
V	0.135	---	3.43	---

Micro8 is a trademark of International Rectifier.

**ON Semiconductor** and  are registered trademarks of Semiconductor Components Industries, LLC (SCILLC). SCILLC reserves the right to make changes without further notice to any products herein. SCILLC makes no warranty, representation or guarantee regarding the suitability of its products for any particular purpose, nor does SCILLC assume any liability arising out of the application or use of any product or circuit, and specifically disclaims any and all liability, including without limitation special, consequential or incidental damages. "Typical" parameters which may be provided in SCILLC data sheets and/or specifications can and do vary in different applications and actual performance may vary over time. All operating parameters, including "Typicals" must be validated for each customer application by customer's technical experts. SCILLC does not convey any license under its patent rights nor the rights of others. SCILLC products are not designed, intended, or authorized for use as components in systems intended for surgical implant into the body, or other applications intended to support or sustain life, or for any other application in which the failure of the SCILLC product could create a situation where personal injury or death may occur. Should Buyer purchase or use SCILLC products for any such unintended or unauthorized application, Buyer shall indemnify and hold SCILLC and its officers, employees, subsidiaries, affiliates, and distributors harmless against all claims, costs, damages, and expenses, and reasonable attorney fees arising out of, directly or indirectly, any claim of personal injury or death associated with such unintended or unauthorized use, even if such claim alleges that SCILLC was negligent regarding the design or manufacture of the part. SCILLC is an Equal Opportunity/Affirmative Action Employer. This literature is subject to all applicable copyright laws and is not for resale in any manner.

### PUBLICATION ORDERING INFORMATION

#### LITERATURE FULFILLMENT:

Literature Distribution Center for ON Semiconductor  
P.O. Box 61312, Phoenix, Arizona 85082-1312 USA  
Phone: 480-829-7710 or 800-344-3860 Toll Free USA/Canada  
Fax: 480-829-7709 or 800-344-3867 Toll Free USA/Canada  
Email: orderlit@onsemi.com

**N. American Technical Support:** 800-282-9855 Toll Free  
USA/Canada

**Japan:** ON Semiconductor, Japan Customer Focus Center  
2-9-1 Kamimeguro, Meguro-ku, Tokyo, Japan 153-0051  
Phone: 81-3-5773-3850

**ON Semiconductor Website:** <http://onsemi.com>

**Order Literature:** <http://www.onsemi.com/litorder>

For additional information, please contact your local Sales Representative.