

NCP5005

Compact Backlight LED Boost Driver

The NCP5005 is a high efficiency boost converter operating in current loop, based on a PFM mode, to drive White LED. The current mode regulation allows a uniform brightness of the LEDs. The chip has been optimized for small ceramic capacitors, capable to supply up to 1.0 W output power.

Features

- 2.7 to 5.5 V Input Voltage Range
- V_{out} to 24 V Output Compliance Allows up to 5 LEDs Drive in Series
- Built-in Overvoltage Protection
- Full EMI Immunity
- Inductor Based Converter brings up to 90% Efficiency
- Constant Output Current Regulation
- 0.3 μ A Standby Quiescent Current
- Includes Dimming Function (PWM)
- Enable Function Driven Directly from Low Battery Voltage Source
- Automatic LEDs Current Matching
- Thermal Shutdown Protection
- All Pins are Fully ESD Protected
- Low EMI Radiation
- Pb-Free Package is Available

Typical Applications

- LED Display Back Light Control
- Keyboard Back Light
- High Efficiency Step Up Converter



ON Semiconductor®

<http://onsemi.com>

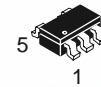

TSOP-5
SN SUFFIX
CASE 483

MARKING DIAGRAM

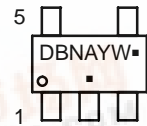

DBN = Device Code
A = Assembly Location
Y = Year
W = Work Week
▪ = Pb-Free Package
(Note: Microdot may be in either location)

PIN CONNECTIONS

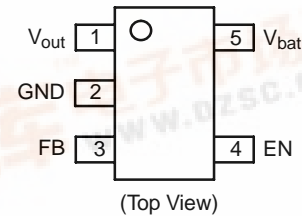

ORDERING INFORMATION

Device	Package	Shipping†
NCP5005SNT1G	TSOP-5 (Pb-Free)	3000 Tape & Reel

†For information on tape and reel specifications, including part orientation and tape sizes, please refer to our Tape and Reel Packaging Specifications Brochure, BRD8011/D.



NCP5005

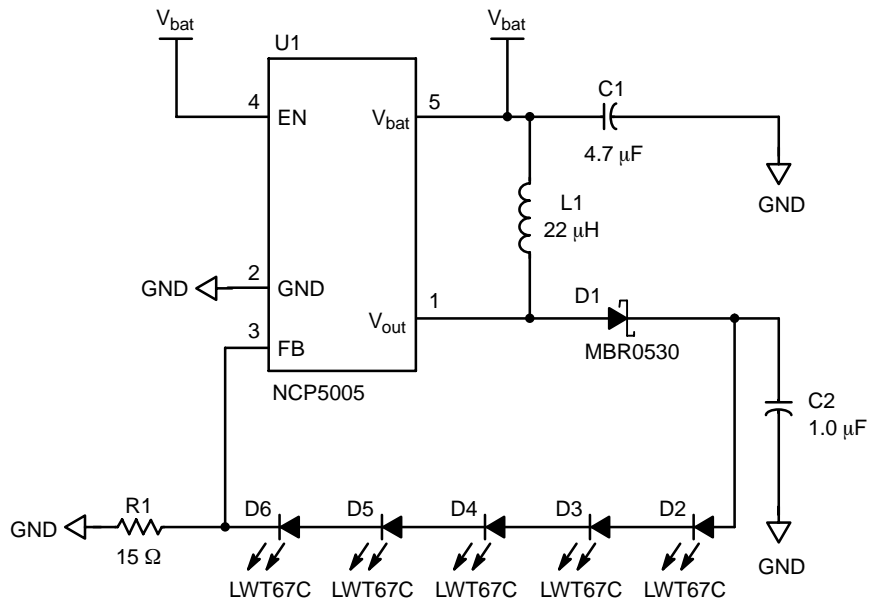

Figure 1. Typical Application

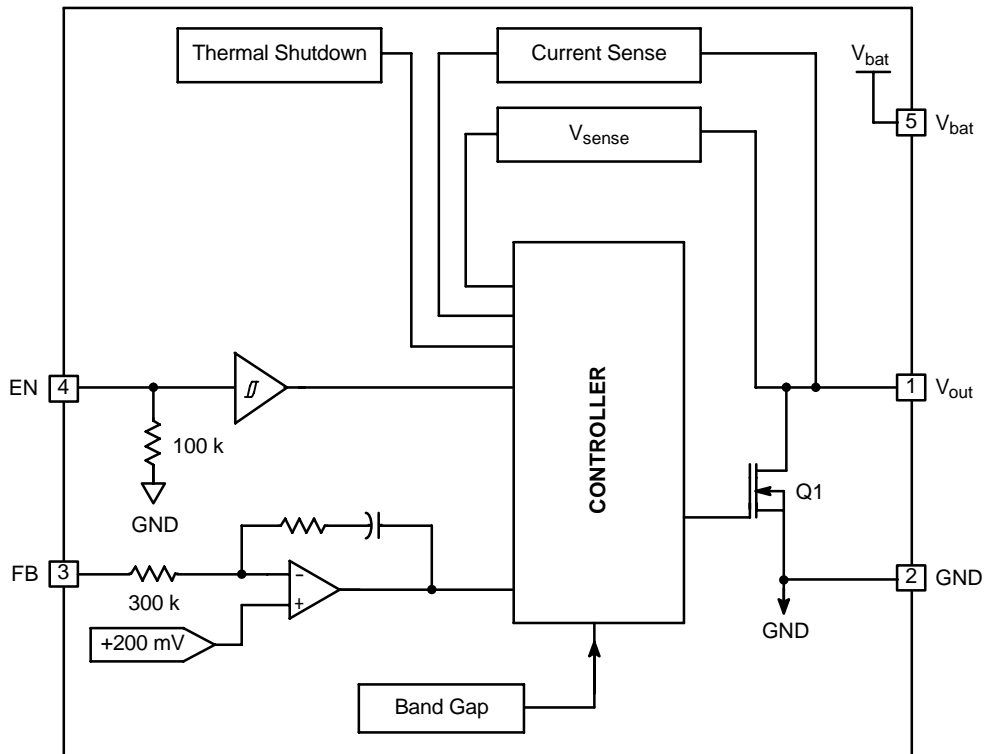

Figure 2. Block Diagram

NCP5005

PIN FUNCTION DESCRIPTION

Pin	Pin Name	Type	Description
1	V _{out}	POWER	This pin is the power side of the external inductor and must be connected to the external Schottky diode. It provides the output current to the load. Since the boost converter operates in a current loop mode, the output voltage can range up to +24 V but shall not extend this limit. However, if the voltage on this pin is higher than the Over Voltage Protection threshold (OVP) the device comes back to shutdown mode. To restart the chip, one must either send a Low to High sequence on Pin EN, or switch off the V _{bat} supply. A capacitor must be used on the output voltage to avoid false triggering of the OVP circuit. This capacitor should be 1.0 μF minimum. Ceramic type, (ESR <100 mΩ), is mandatory to achieve the high end efficiency. This capacitor limits the noise created by the fast transients present in this circuitry. In order to limit the inrush current and to operate with an acceptable start-up time, it is recommended to use any value between 1.0 μF and 8.2 μF capacitor maximum. Care must be observed to avoid EMI through the PCB copper tracks connected to this pin.
2	GND	POWER	This pin is the system ground for the NCP5005 and carries both the power and the analog signals. High quality ground must be provided to avoid spikes and/or uncontrolled operation. Care must be observed to avoid high-density current flow in a limited PCB copper track. Ground plane technique is recommended.
3	FB	ANALOG INPUT	This pin provides the output current range adjustment by means of a sense resistor connected to the analog control or with a PWM control. The dimming function can be achieved by applying a PWM voltage technique to this pin (see Figure 29). The current output tolerance depends upon the accuracy of this resistor. Using a ±5% metal film resistor or better, yields a good enough output current accuracy. Note: A built-in comparator switch OFF the DC/DC converter if the voltage sensed across this pin and ground is higher than 700 mV (typical).
4	EN	DIGITAL INPUT	This is an Active-High logic input which enables the boost converter. The built-in pull down resistor disables the device when the EN pin is left open. The LED brightness can be controlled by applying a pulse width modulated signal to the enable pin (see Figure 31).
5	V _{bat}	POWER	The external voltage supply is connected to this pin. A high quality reservoir capacitor must be connected across Pin 1 and Ground to achieve the specified output voltage parameters. A 4.7 μF/6.3 V, low ESR capacitor must be connected as close as possible across Pin 5 and ground Pin 2. The X5R or X7R ceramic MURATA types are recommended. The return side of the external inductor shall be connected to this pin. Typical application will use a 22 μH, size 1008, to handle the 1.0 to 100 mA max output current range. On the other hand, when the desired output current is above 20 mA, the inductor shall have an ESR < 1.5 Ω to achieve a good efficiency over the V _{bat} range.

NCP5005

MAXIMUM RATINGS

Rating	Symbol	Value	Unit
Power Supply	V_{bat}	6.0	V
Output Power Supply Voltage Compliance	V_{out}	28	V
Digital Input Voltage Digital Input Current	EN	$-0.3 < V_{in} < V_{bat} + 0.3$ 1.0	V mA
ESD Capability (Note 1) Human Body Model (HBM) Machine Model (MM)	V_{ESD}	2.0 200	kV V
TSOP-5 Package Power Dissipation @ $T_A = +85^{\circ}\text{C}$ (Note 2) Thermal Resistance, Junction-to-Air	P_D $R_{\theta JA}$	160 250	mW $^{\circ}\text{C}/\text{W}$
Operating Ambient Temperature Range	T_A	-25 to +85	$^{\circ}\text{C}$
Operating Junction Temperature Range	T_J	-25 to +125	$^{\circ}\text{C}$
Maximum Junction Temperature	T_{Jmax}	+150	$^{\circ}\text{C}$
Storage Temperature Range	T_{stg}	-65 to +150	$^{\circ}\text{C}$

Maximum ratings are those values beyond which device damage can occur. Maximum ratings applied to the device are individual stress limit values (not normal operating conditions) and are not valid simultaneously. If these limits are exceeded, device functional operation is not implied, damage may occur and reliability may be affected.

- This device series contains ESD protection and exceeds the following tests:
Human Body Model (HBM) ± 2.0 kV per JEDEC standard: JESD22-A114
Machine Model (MM) ± 200 V per JEDEC standard: JESD22-A115
- The maximum package power dissipation limit must not be exceeded.
- Latch-up current maximum rating: ± 100 mA per JEDEC standard: JESD78.
- Moisture Sensivity Level (MSL): 1 per IPC/JEDEC standard: J-STD-020A.

POWER SUPPLY SECTION (Typical values are referenced to $T_A = +25^{\circ}\text{C}$, Min & Max values are referenced -25°C to $+85^{\circ}\text{C}$ ambient temperature, unless otherwise noted.)

Rating	Pin	Symbol	Min	Typ	Max	Unit
Power Supply	4	V_{bat}	2.7	-	5.5	V
Output Load Voltage Compliance	5	V_{out}	21	24	-	V
Continuous DC Current in the Load @ $V_{out} = 3 \times \text{LED}$, $L = 22 \mu\text{H}$, $\text{ESR} < 1.5 \Omega$, $V_{bat} = 3.60 \text{ V}$	5	I_{out}	50	-	-	mA
Stand By Current, @ $I_{out} = 0 \text{ mA}$, EN = L, $V_{bat} = 3.6 \text{ V}$	4	I_{stdb}	-	0.3	-	μA
Stand By Current, @ $I_{out} = 0 \text{ mA}$, EN = L, $V_{bat} = 5.5 \text{ V}$	4	I_{stdb}	-	0.8	3.0	μA
Inductor Discharging Time @ $V_{bat} = 3.6 \text{ V}$, $L = 22 \mu\text{H}$, $3 \times \text{LED}$, $I_{out} = 10 \text{ mA}$	4	T_{offmax}	-	320	-	ns
Thermal Shutdown Protection	-	T_{SD}	-	160	-	$^{\circ}\text{C}$
Thermal Shutdown Protection Hysteresis	-	T_{SDH}	-	30	-	$^{\circ}\text{C}$

NCP5005

ANALOG SECTION (Typical values are referenced to $T_A = +25^\circ\text{C}$, Min & Max values are referenced -25°C to $+85^\circ\text{C}$ ambient temperature, unless otherwise noted.)

Rating	Pin	Symbol	Min	Typ	Max	Unit
High Level Input Voltage Low Level Input Voltage	4	EN	1.3 -	- -	- 0.4	V V
EN Pull Down Resistor	4	R_{EN}	-	100	-	$k\Omega$
Feedback Voltage Threshold	3	FB	185	200	225	mV
Output Current Stabilization Time Delay following a DC/DC Start-up, @ $V_{bat} = 3.60\text{ V}$, $L = 22\ \mu\text{H}$, $I_{out} = 20\text{ mA}$	1	I_{outdy}	-	100	-	μs
Internal Switch ON Resistor @ $T_{amb} = +25^\circ\text{C}$	1	QR_{DSON}	-	1.7	-	Ω

5. The overall tolerance depends upon the accuracy of the external resistor.

ESD PROTECTION

The NCP5005 includes silicon devices to protect the pins against the ESD spikes voltages. To cope with the different ESD voltages developed in the applications, the built-in structures have been designed to handle $\pm 2.0\text{ kV}_{in}$ Human Body Model (HBM) and $\pm 200\text{ V}$ in Machine Model (MM) on each pin.

DC/DC OPERATION

The DC/DC converter is designed to supply a constant current to the external load, the circuit being powered from a standard battery supply. Since the regulation is made by

means of a current loop, the output voltage will varies depending upon the dynamic impedance presented by the load.

Considering high intensity LED, the output voltage can range from a low 6.40 V (two LED in series biased with a low current), up to 21 V, the voltage compliance the chip can sustain continuously.

The basic DC/DC structure is depicted in Figure 3. With a 28 V maximum rating voltage capability, the power device can accommodate high voltage source without any leakage current downgrading.

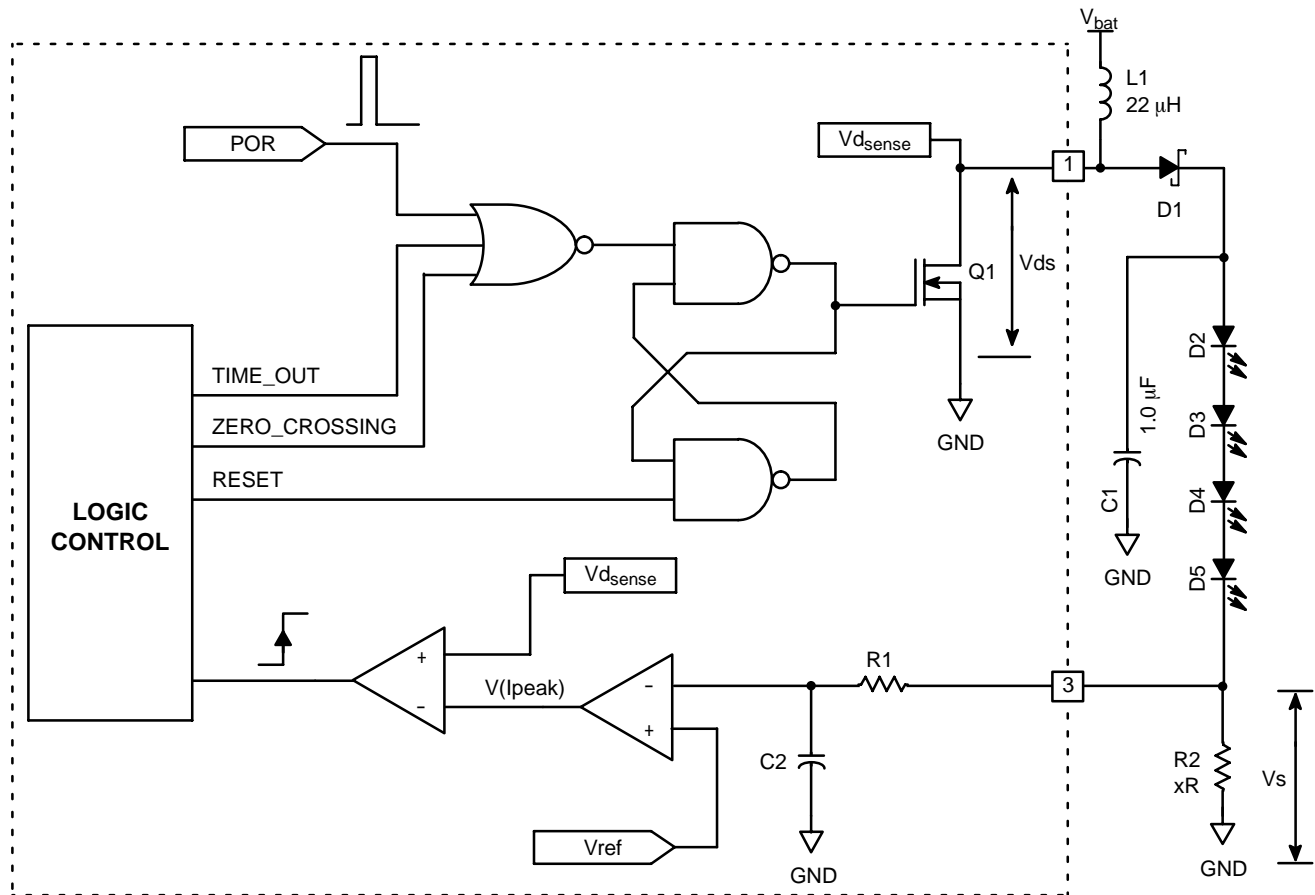

Figure 3. Basic DC/DC Converter Structure

NCP5005

Basically, the chip operates with two cycles:

Cycle #1: time t_1 , the energy is stored into the inductor

Cycle #2: time t_2 , the energy is dumped to the load

The POR signal sets the flip-flop and the first cycle takes place. When the current hits the peak value, defined by the

error amplifier associated to the loop regulation, the flip-flop resets, the NMOS is deactivated and the current is dumped into the load. Since the timings depend on the environment, the internal timer limits the toff cycle to 320 ns (typical), making sure the system operates in a continuous mode to maximize the energy transfer.

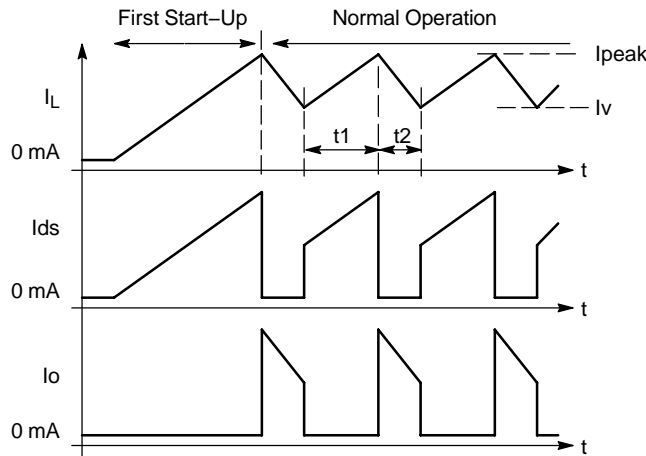

Figure 4. Basic DC-DC Operation

Based on the data sheet, the current flowing into the inductor is bounded by two limits:

- I_{peak} Value: Internally fixed to 350 mA typical
- I_v Value: Limited by the fixed Toff time built in the chip (320 ns typical)

The system operates in a continuous mode as depicted in Figure 4 and t_1 and t_2 times can be derived from basic equations. (Note: The equations are for theoretical analysis only, they do not include the losses.)

$$L = E \cdot \frac{dl}{dt} \quad (\text{eq. 1})$$

Let $V_{bat} = E$, then:

$$t_1 = \frac{(I_p - I_v) \cdot L}{V_{bat}} \quad (\text{eq. 2})$$

$$t_2 = \frac{(I_p - I_v) \cdot L}{V_o - V_{bat}} \quad (\text{eq. 3})$$

Since $t_2 = 320$ ns typical and $V_o = 21$ V maximum, then (assuming a typical $V_{bat} = 3.0$ V):

$$\Delta I = \frac{t_2 \cdot (V_o - V_{bat})}{L} \quad (\text{eq. 4})$$

$$\Delta I_{max} = \frac{320 \text{ ns} \cdot (21 - 3.0)}{22 \mu\text{H}} = 261 \text{ mA}$$

Of course, from a practical stand point, the inductor must be sized to cope with the peak current present in the circuit

to avoid saturation of the core. On top of that, the ferrite material shall be capable to operate at high frequency (1.0 MHz) to minimize the Foucault's losses developed during the cycles.

The operating frequency can be derived from the electrical parameters. Let $V = V_o - V_{bat}$, rearranging Equation 1:

$$t_{on} = \frac{dl \cdot L}{E} \quad (\text{eq. 5})$$

Since toff is nearly constant (according to the 320 ns typical time), the dI is constant for a given load and inductance value. Rearranging Equation 5 yields:

$$t_{on} = \frac{V \cdot dt \cdot L}{E} \quad (\text{eq. 6})$$

Let $E = V_{bat}$, and $V_{opk} =$ output peak voltage, then:

$$t_{on} = \frac{(V_{opk} - V_{bat}) \cdot dt}{V_{bat}} \quad (\text{eq. 7})$$

Finally, the operating frequency is:

$$f = \frac{1}{t_{on} + t_{off}} \quad (\text{eq. 8})$$

The output power supplied by the NCP5005 is limited to one watt: Figure 5 shows the maximum power that can be delivered by the chip as a function of the output voltage.

NCP5005

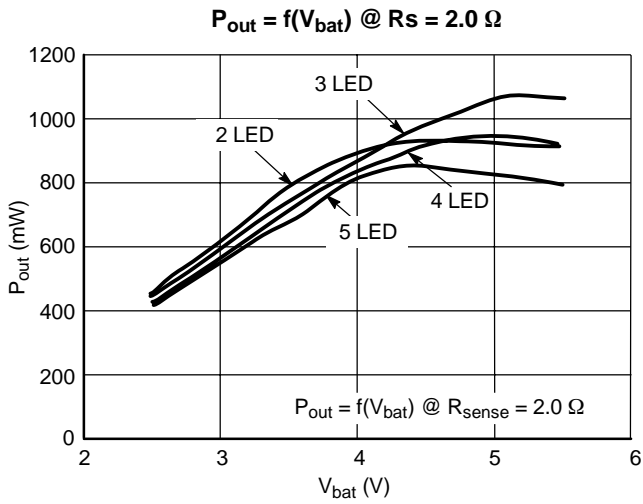
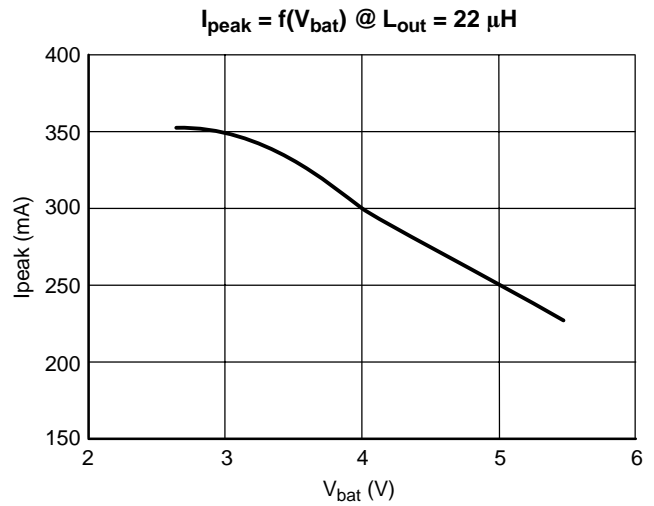
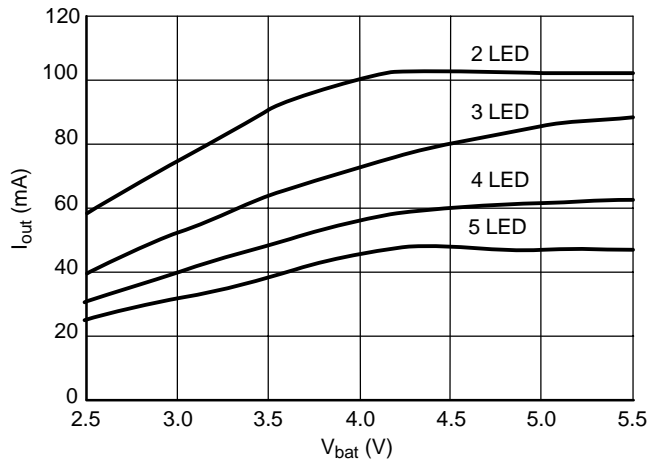

Figure 5. Maximum Output Power as a Function of the Battery Supply Voltage



Test conditions: L = 22 μH , R_{sense} = 10 Ω , T_{amb} = +20°C

Figure 6. Typical Inductor Peak Current as a Function of V_{bat} Voltage



Test conditions: L = 22 μH , R_{sense} = 2.0 Ω , T_{amb} = +25°C

Figure 7. Maximum Output Current as a Function of V_{bat}

NCP5005

Output Current Range Set-Up

The current regulation is achieved by means of an external sense resistor connected in series with the LED string.

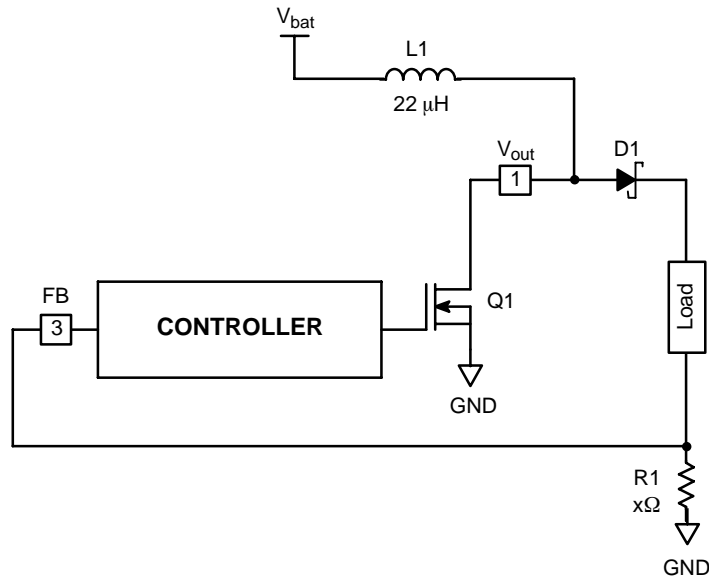

Figure 8. Output Current Feedback

The current flowing through the LED creates a voltage drop across the sense resistor R1. The voltage drop is constantly monitored internally, and maximum peak current allowed in the inductor is set accordingly in order to keep constant this voltage drop (and thus the current flowing through the LED). For example, should one need a 10 mA output current, the sense resistor should be sized according to the following equation:

$$R_1 = \frac{\text{Feedback Threshold}}{I_{\text{out}}} = \frac{200 \text{ mV}}{10 \text{ mA}} = 20 \Omega \quad (\text{eq. 9})$$

A standard 5% tolerance resistor, 22 Ω SMD device, yields 9.09 mA, good enough to fulfill the back light demand. The typical application schematic diagram is provided in Figure 9.

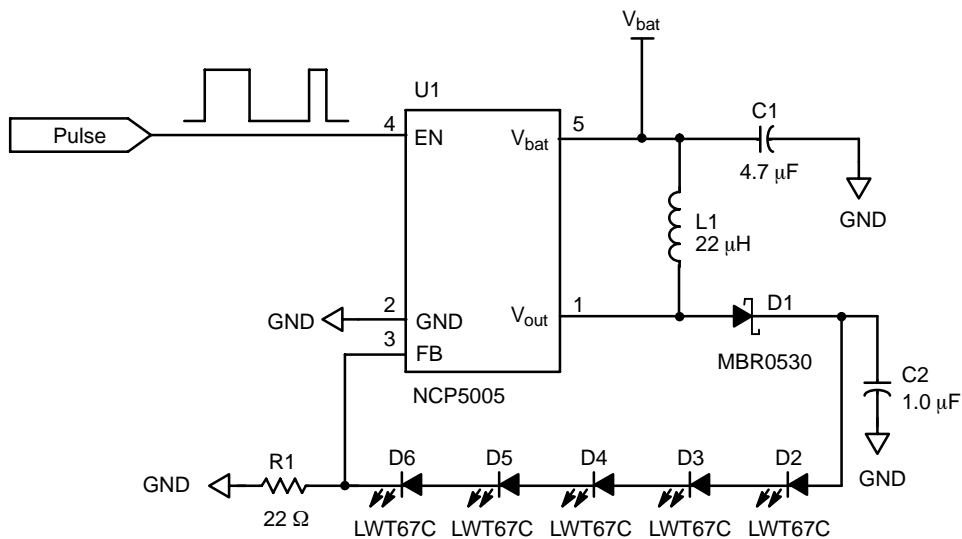

Figure 9. Basic Schematic Diagram

NCP5005

Output Load Drive

In order to optimize the built-in Boost capabilities, one shall operate the NCP5005 in the continuous output current mode. Such a mode is achieved by using an external reservoir capacitor (see Table 1) across the LED.

At this point, the peak current flowing into the LED diodes shall be within the maximum ratings specified for these devices. Of course, pulsed operation can be achieved, due to the EN signal Pin 4, to force high current into the LED when necessary.

The Schottky diode D1, associated with capacitor C2 (see Figure 9), provides a rectification and filtering function.

When a pulse-operating mode is acceptable:

- A PWM mode control can be used to adjust the output current range by means of a resistor and a capacitor connected across FB pin. On the other hand, the Schottky diode can be removed and replaced by at least one LED diode, keeping in mind such LED shall sustain the large pulsed peak current during the operation.

TYPICAL OPERATING CHARACTERISTICS

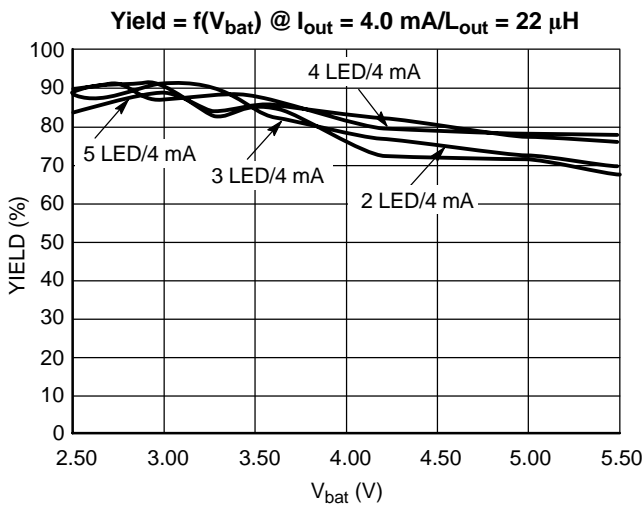

Figure 10. Overall Efficiency vs. Power Supply @ $I_{out} = 4.0 \text{ mA}$, $L = 22 \mu\text{H}$

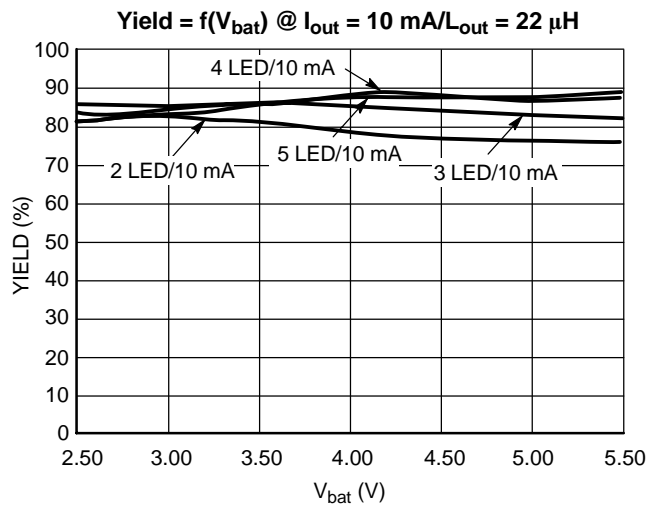

Figure 11. Overall Efficiency vs. Power Supply @ $I_{out} = 10 \text{ mA}$, $L = 22 \mu\text{H}$

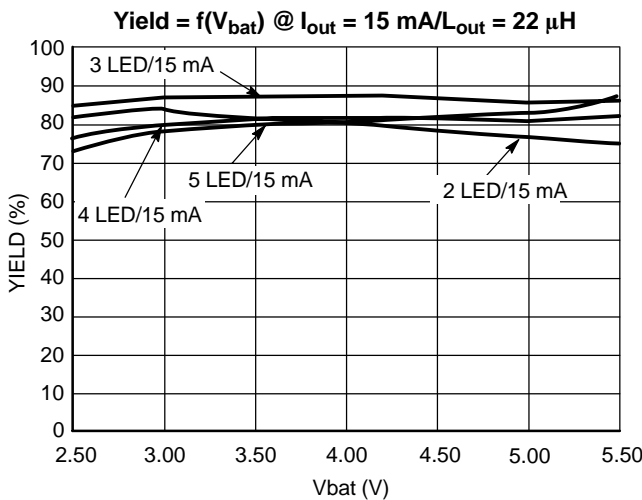

Figure 12. Overall Efficiency vs. Power Supply @ $I_{out} = 15 \text{ mA}$, $L = 22 \mu\text{H}$

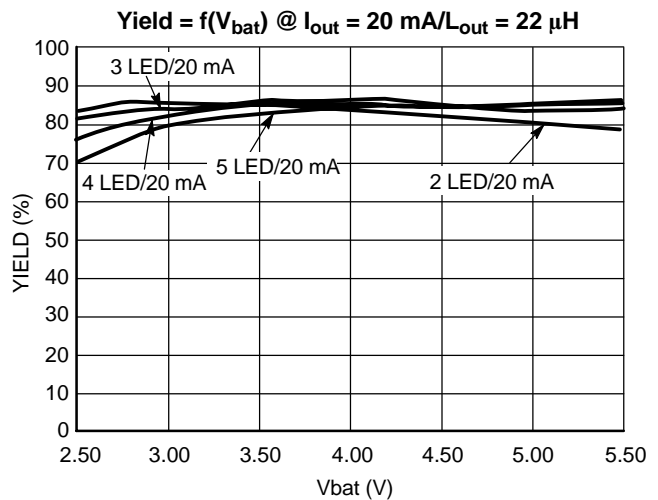
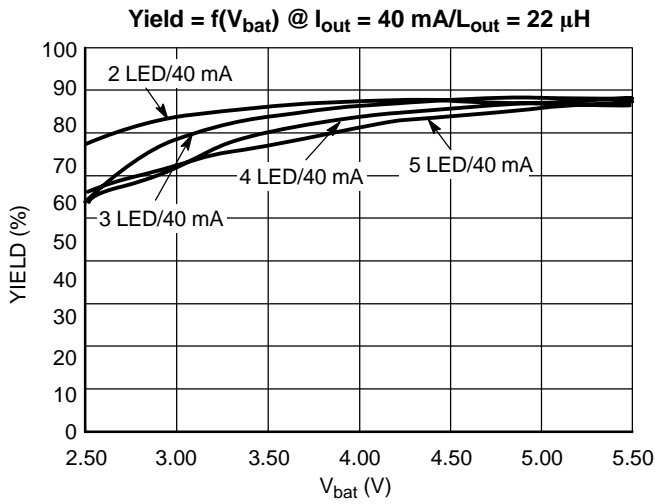

Figure 13. Overall Efficiency vs. Power Supply @ $I_{out} = 20 \text{ mA}$, $L = 22 \mu\text{H}$

NCP5005



All curve conditions: $L = 22\ \mu\text{H}$, $C_{in} = 4.7\ \mu\text{F}$, $C_{out} = 1.0\ \mu\text{F}$,
Typical curve @ $T^\circ = +25^\circ\text{C}$

Figure 14. Overall Efficiency vs. Power Supply @ $I_{out} = 40\text{ mA}$, $L = 22\ \mu\text{H}$

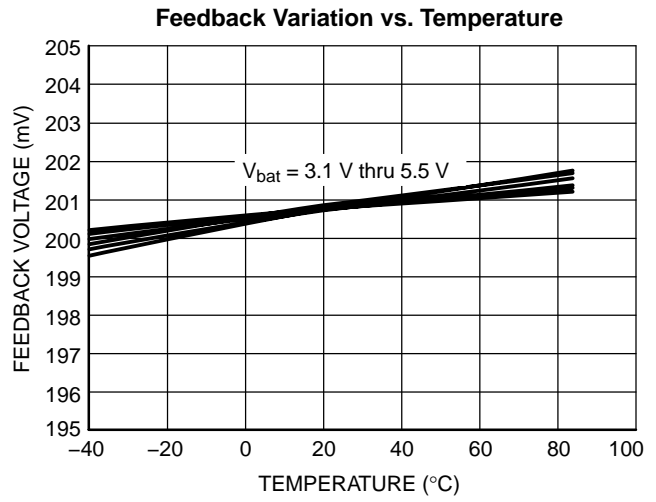

Figure 15. Feedback Voltage Stability

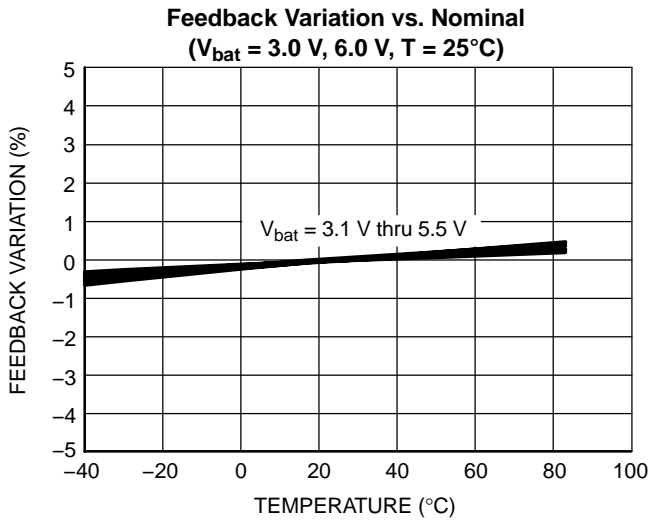

Figure 16. Feedback Voltage Variation

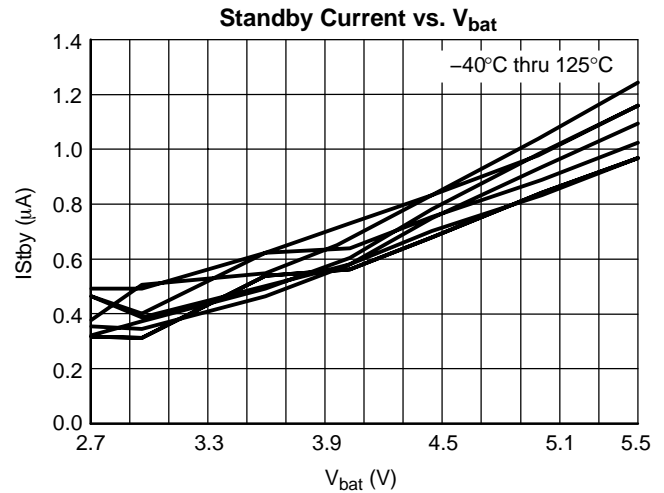

Figure 17. Standby Current

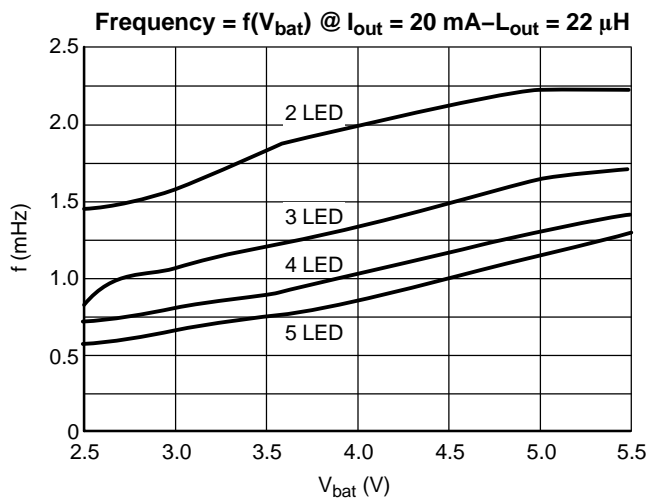

Figure 18. Typical Operating Frequency

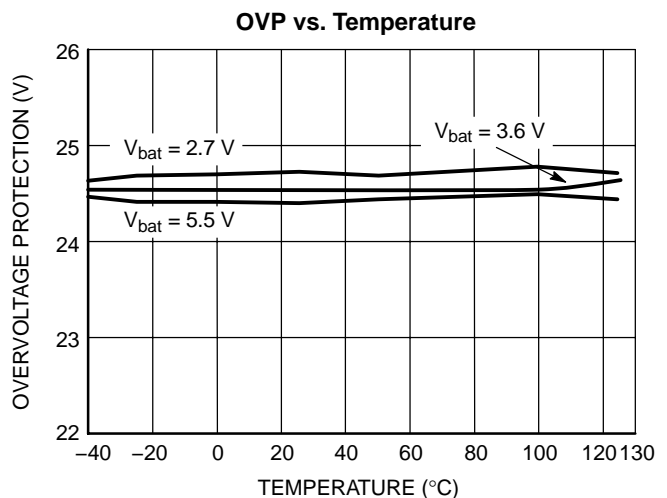
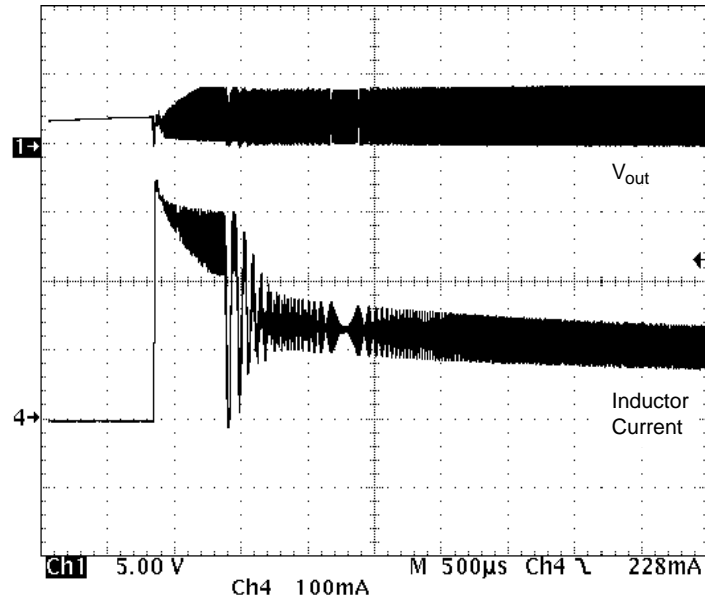

Figure 19. Overvoltage Protection

NCP5005

TYPICAL OPERATING WAVEFORMS



Conditions: $V_{bat} = 3.6$ V, $L_{out} = 22$ μ H, 5 LED, $I_{out} = 15$ mA

Figure 20. Typical Power Up Response

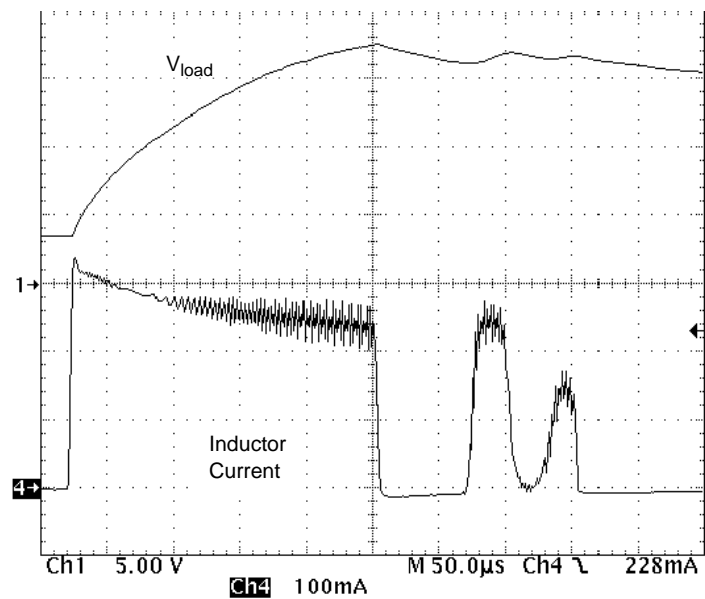

Conditions: $V_{bat} = 3.6$ V, $L_{out} = 22$ μ H, 5 LED, $I_{out} = 15$ mA

Figure 21. Typical Start-Up Inductor Current and Output Voltage

NCP5005

TYPICAL OPERATING WAVEFORMS

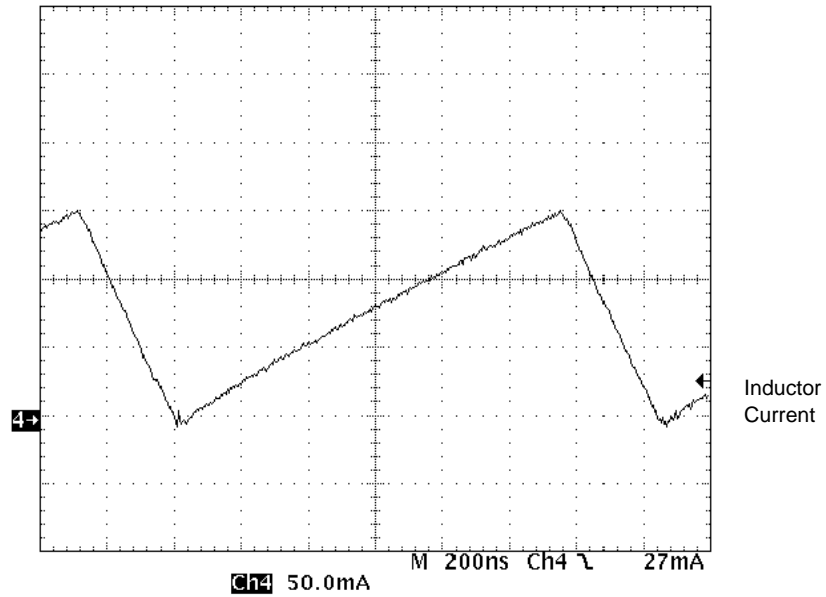

Conditions: $V_{bat} = 3.6\text{ V}$, $L_{out} = 22\ \mu\text{H}$, 5 LED, $I_{out} = 15\text{ mA}$

Figure 22. Typical Inductor Current

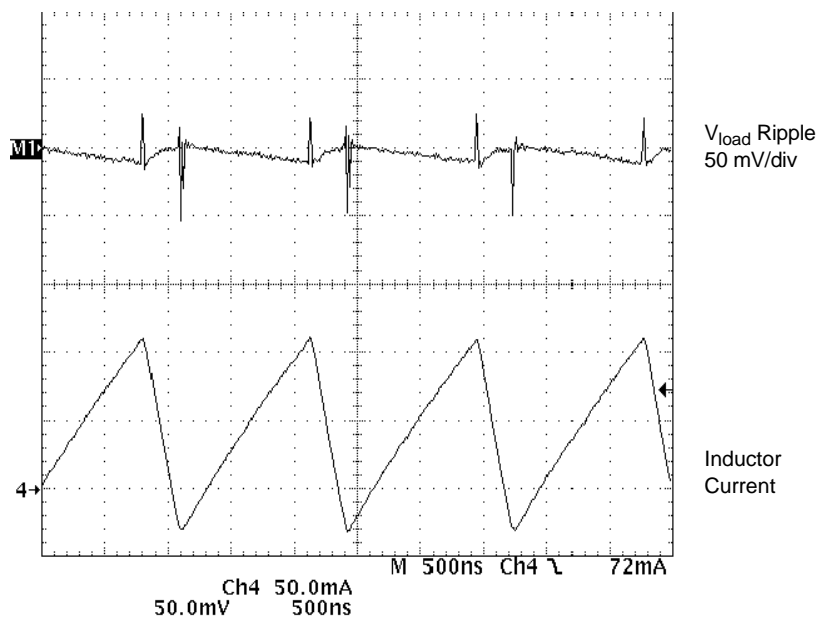

Conditions: $V_{bat} = 3.6\text{ V}$, $L_{out} = 22\ \mu\text{H}$, 5 LED, $I_{out} = 15\text{ mA}$

Figure 23. Typical Output Load Voltage Ripple

NCP5005

TYPICAL OPERATING WAVEFORMS

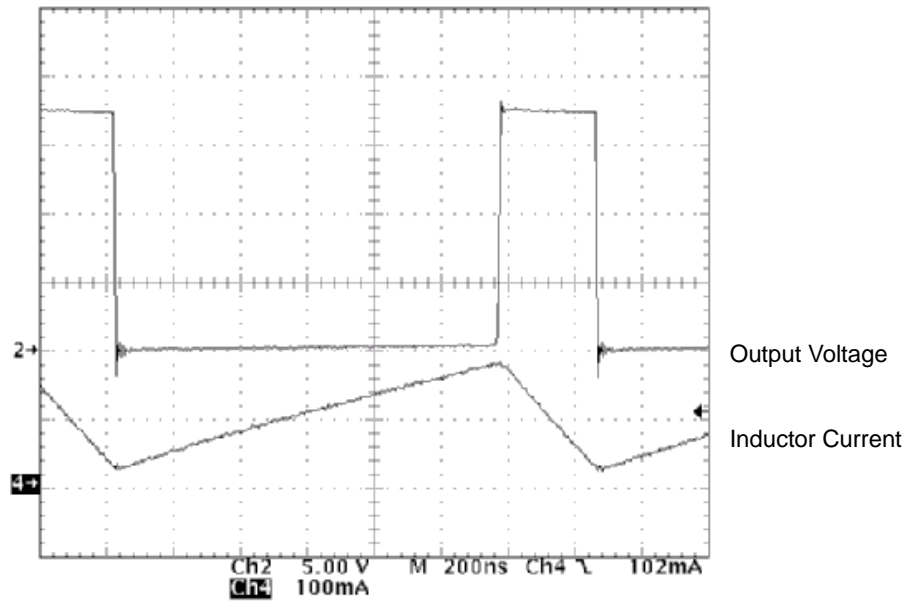

Test Conditions: $L = 22 \mu\text{H}$, $I_{\text{out}} = 15 \text{ mA}$, $V_{\text{bat}} = 3.6 \text{ V}$, Ambient Temperature

Figure 24. Typical Output Peak Voltage

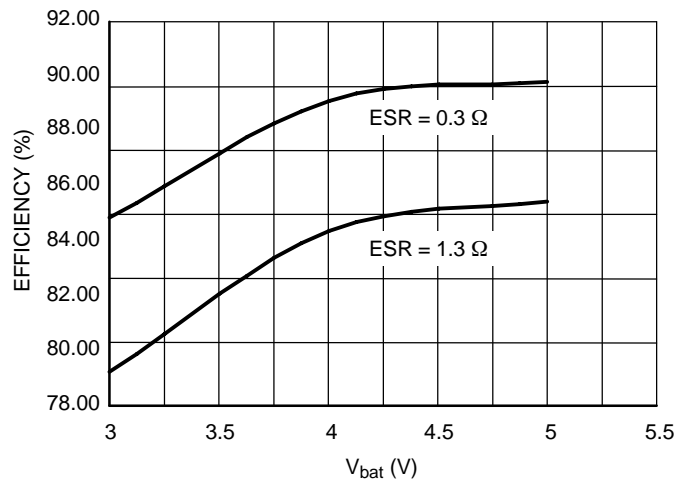

NCP5005: Efficiency = $f(\text{ESR})$ @ 5 LED, $I_{\text{Led}} = 20 \text{ mA}$

Figure 25. Efficiency as a Function of V_{bat} and Inductor ESR

NCP5005

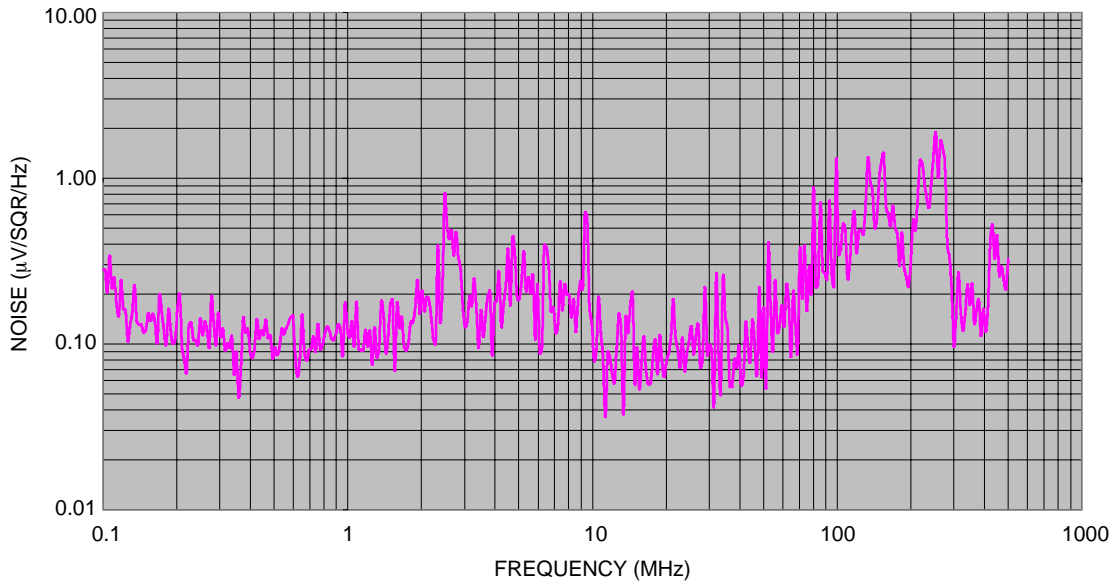
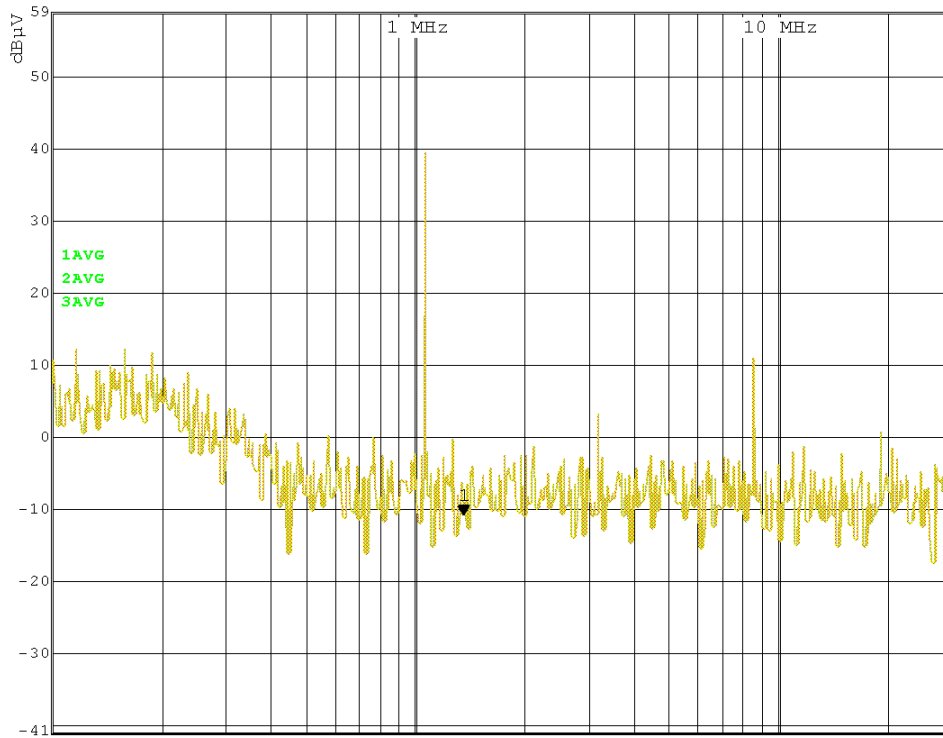

Figure 26. Noise Returned to the Battery



Test Conditions: $V_{\text{bat}} = 3.6 \text{ V}$, $I_{\text{out}} = 20 \text{ mA}$, string of 3 LED (OSRAM LWT67C)

Figure 27. Relative EMI Over 100 kHz – 30 MHz Bandwidth

NCP5005

TYPICAL APPLICATIONS CIRCUITS

Standard Feedback

The standard feedback provides a constant current to the LED, independently of the V_{bat} supply and number of LED

associated in series. Figure 28 depicts a typical application to supply 13 mA to the load.

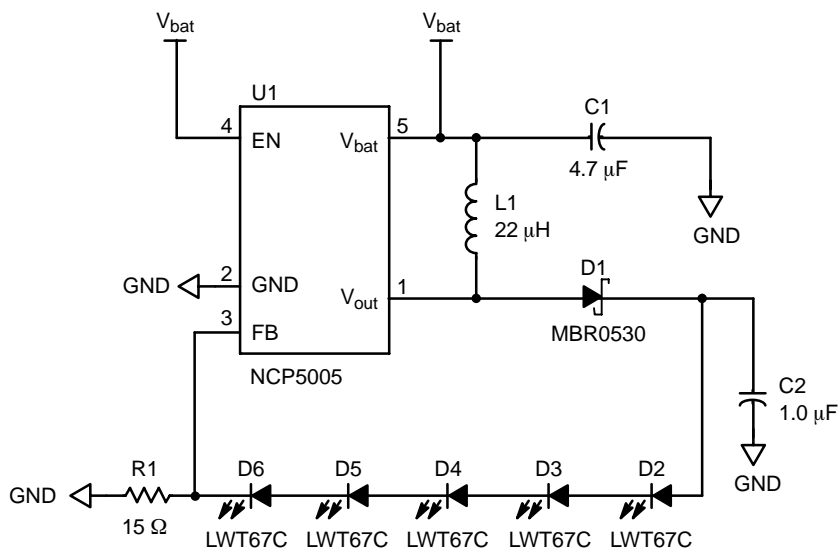

Figure 28. Basic DC Current Mode Operation with Analog Feedback

PWM Operation

The analog feedback Pin 3 provides a way to dim the LED by means of an external PWM signal as depicted in Figure 29. By optimizing the internal high impedance presented by the FB pin, one can set up a simple R/C network to accommodate such a dimming function. Two modes of operation can be considered:

- Pulsed mode, with no filtering
- Averaged mode with filtering capacitor

Although the pulsed mode will provide a good dimming function, from a human eye standpoint, it will continuously

start and stop the converter, yielding high transients. These transients might generate spikes difficult to filter out in the rest of the application, a situation not recommended. The output current depends upon the duty cycle of the signal presented to the node Pin 3: this is very similar to the digital control discussed in Figure 31.

The average mode yields a noise free operation since the converter operates continuously, together with a very good dimming function. The cost is an extra resistor and one extra capacitor, both being low cost parts.

NCP5005

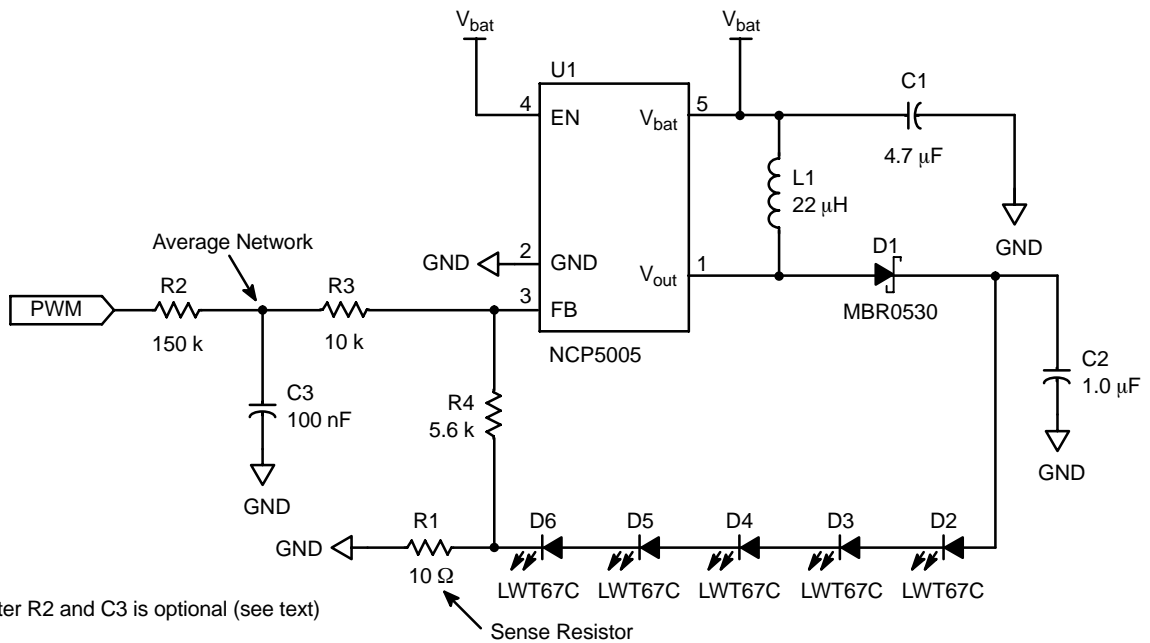

Figure 29. Basic DC Current Mode Operation with PWM Control

To implement such a function, let consider the feedback input as an operational amplifier with a high impedance input (reference schematic Figure 29). The analog loop will keep going to balance the current flowing through the sense resistor R1 until the feedback voltage is 200 mV. An extra resistor (R4) isolates the FB node from low resistance to ground, making possible to add an external voltage to this pin.

The time constant $R2/C3$ generates the voltage across C3, added to the node Pin 1, while $R2/R3/R4/R1/C3$ create the discharge time constant. In order to minimize the pick up noise at FB node, the resistors shall have relative medium

value, preferably well below $1.0\text{ M}\Omega$. Consequently, let $R2 = 150\text{ k}$, $R3 = 10\text{ k}$ and $R4 = 5.6\text{ k}$. On the other hand, the feedback delay to control the luminosity of the LED shall be acceptable by the user, 10 ms or less being a good compromise. The time constant can now be calculated based on a 400 mV offset voltage at the $C3/R2/R3$ node to force zero current to the LED. Assuming the PWM signal comes from a standard gate powered by a 3.0 V supply, running at 10 kHz, then a full dimming of the LED can be achieved with a 95% span of the Duty Cycle signal. Figure 30 depicts the behavior under such PWM analog mode.

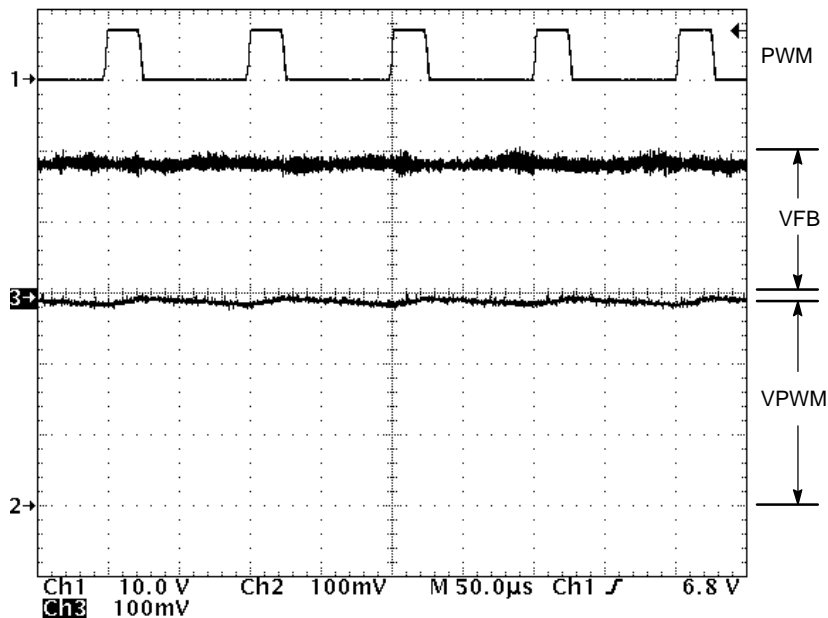

Figure 30. Operation with Analog PWM, $f = 10\text{ kHz}$, DC = 25%

NCP5005

Digital Control

Due to the EN pin, a digitally controlled luminosity can be implemented by providing a PWM signal to this pin (see Figure 31). The output current depends upon the Duty

Cycle, but care must be observed as the DC/DC converter is continuously pulsed ON/OFF and noise are likely to be generated.

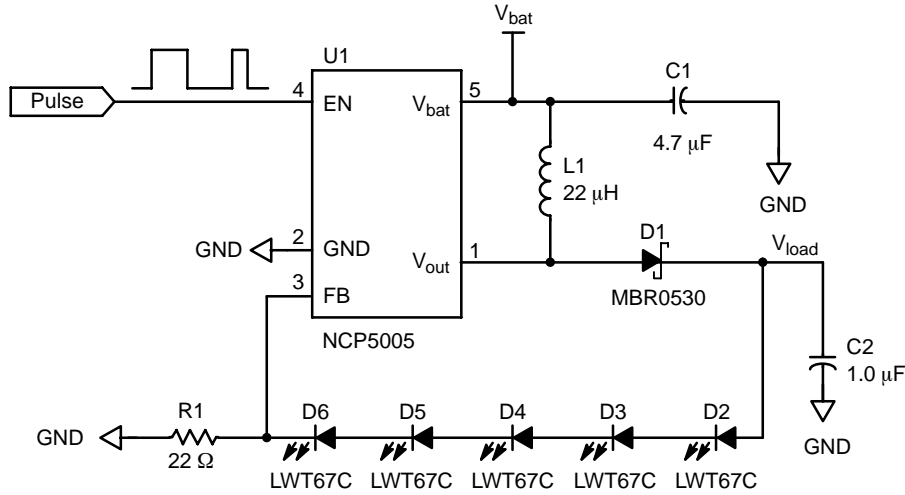

NOTE: Pulse width and frequency depends upon the application constraints.

Figure 31. Typical Semi-Pulsed Mode of Operation

The PWM operation, using the EN pin as a digital control, is depicted in Figures 32 and 33. The tests have

been carried out at room temperature with $V_{bat} = 3.60\text{ V}$, $L = 22\ \mu\text{H}$, five LEDs in series, $R_{FB} = 22\ \Omega$.

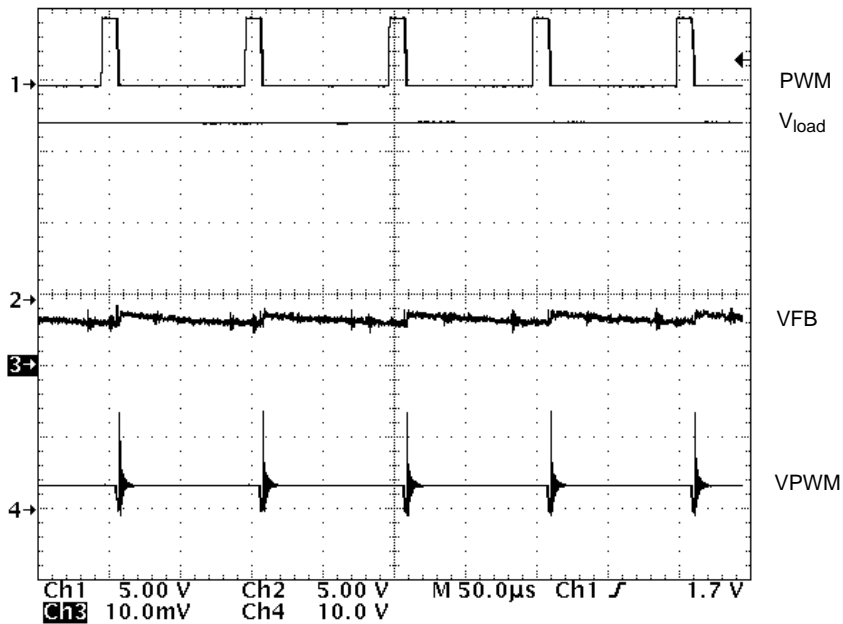

Figure 32. Operation @ PWM = 10 kHz, DC = 10%

NCP5005

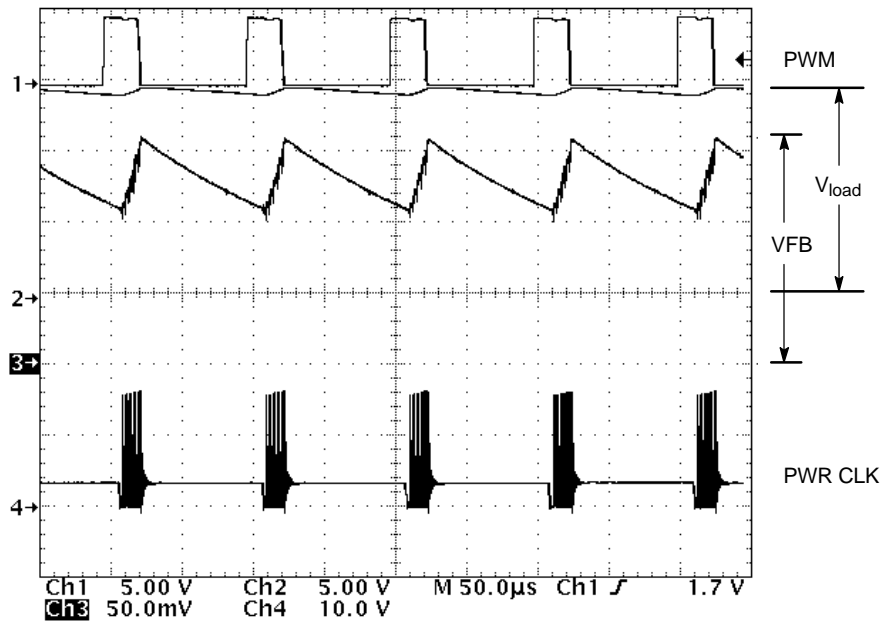

Figure 33. Operation @ PWM = 10 kHz, DC = 25%

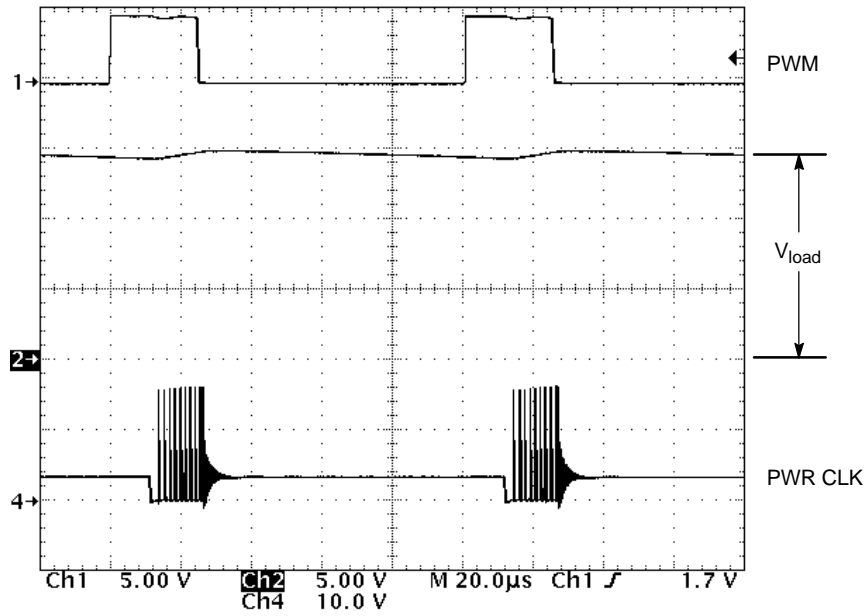

Figure 34. Magnified View of Operation @ PWM = 10 kHz, DC = 25%

NCP5005

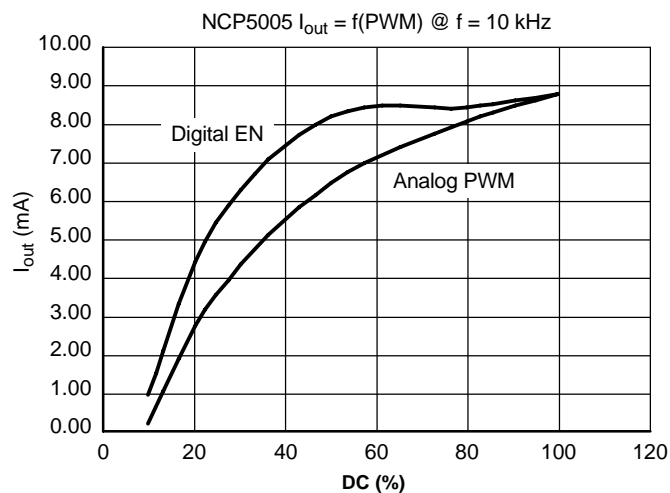

Figure 35. Output Current as a Function of the Operating Condition

Table 1. Recommended Passive Parts

Part	Manufacturer	Description	Part Number
Ceramic Capacitor 1.0 $\mu\text{F}/16 \text{ V}$	MURATA	GRM42 – X7R	GRM42–6X7R–105K16
Ceramic Capacitor 1.0 $\mu\text{F}/25 \text{ V}$	MURATA	GRM42 – X5R	GRM
Ceramic Capacitor 4.7 $\mu\text{F}/6.3 \text{ V}$	MURATA	GRM40 – X5R	GRM40–X5R–475K6.3
Inductor 22 μH	CoilCraft	1008PS – Shielded	1008PS–223MC
Inductor 22 μH	CoilCraft	Power Wafer	LPQ4812–223KXC
Inductor 22 μH	WURTH	Power Choke	744031220
Inductor 22 μH	TDK	Power Inductor	VLP4614T–220MR40

NCP5005

Typical LEDs Load Mapping

Since the output power is voltage battery limited (see Figure 5), one shall arrange the LED to cope with a specific need. In particular, since the power cannot extend 600 mW

under realistic battery supply, powering ten LED can be achieved by a series/parallel combination as depicted in Figure 36.

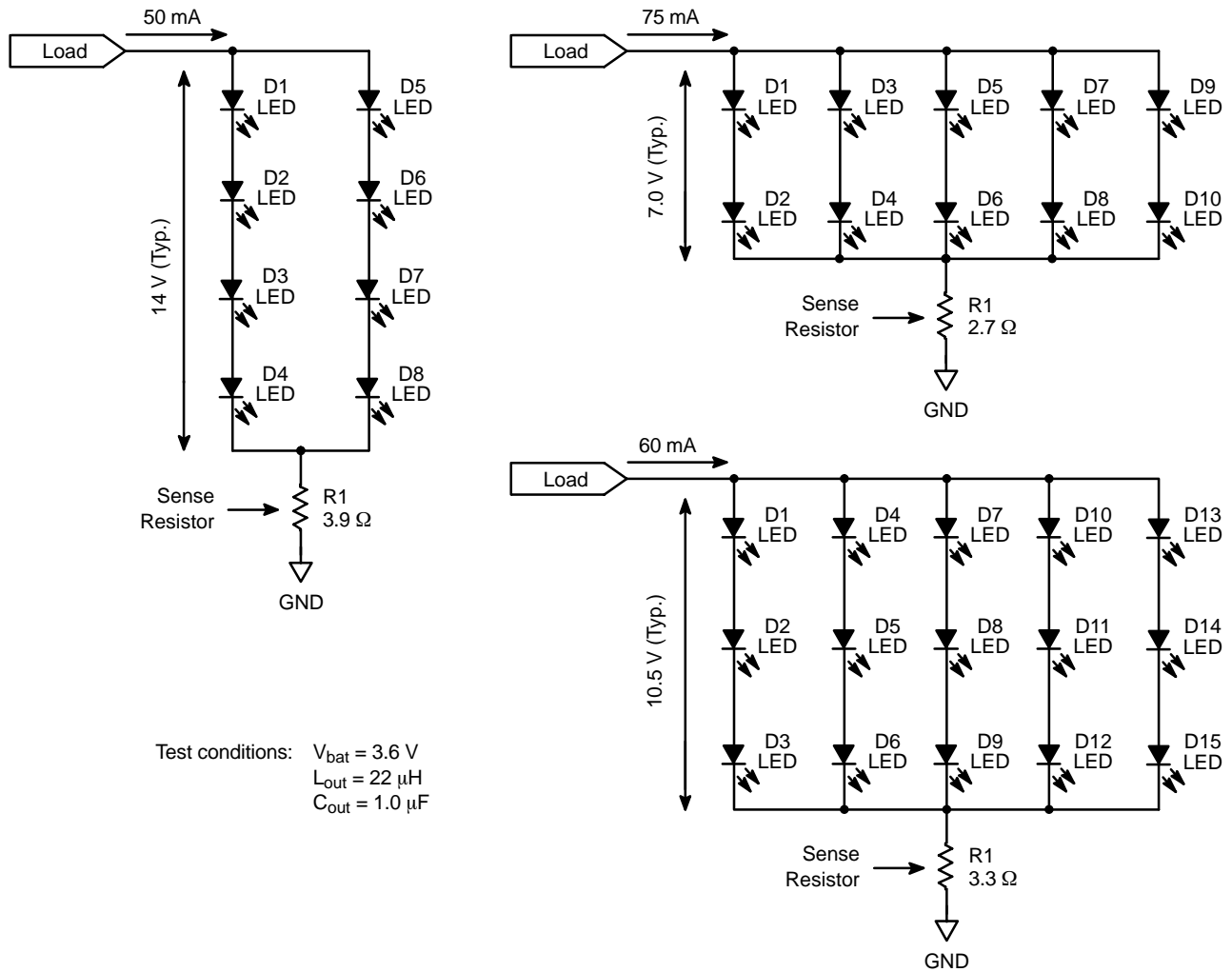

Figure 36. Examples of Possible LED Arrangements

NCP5005

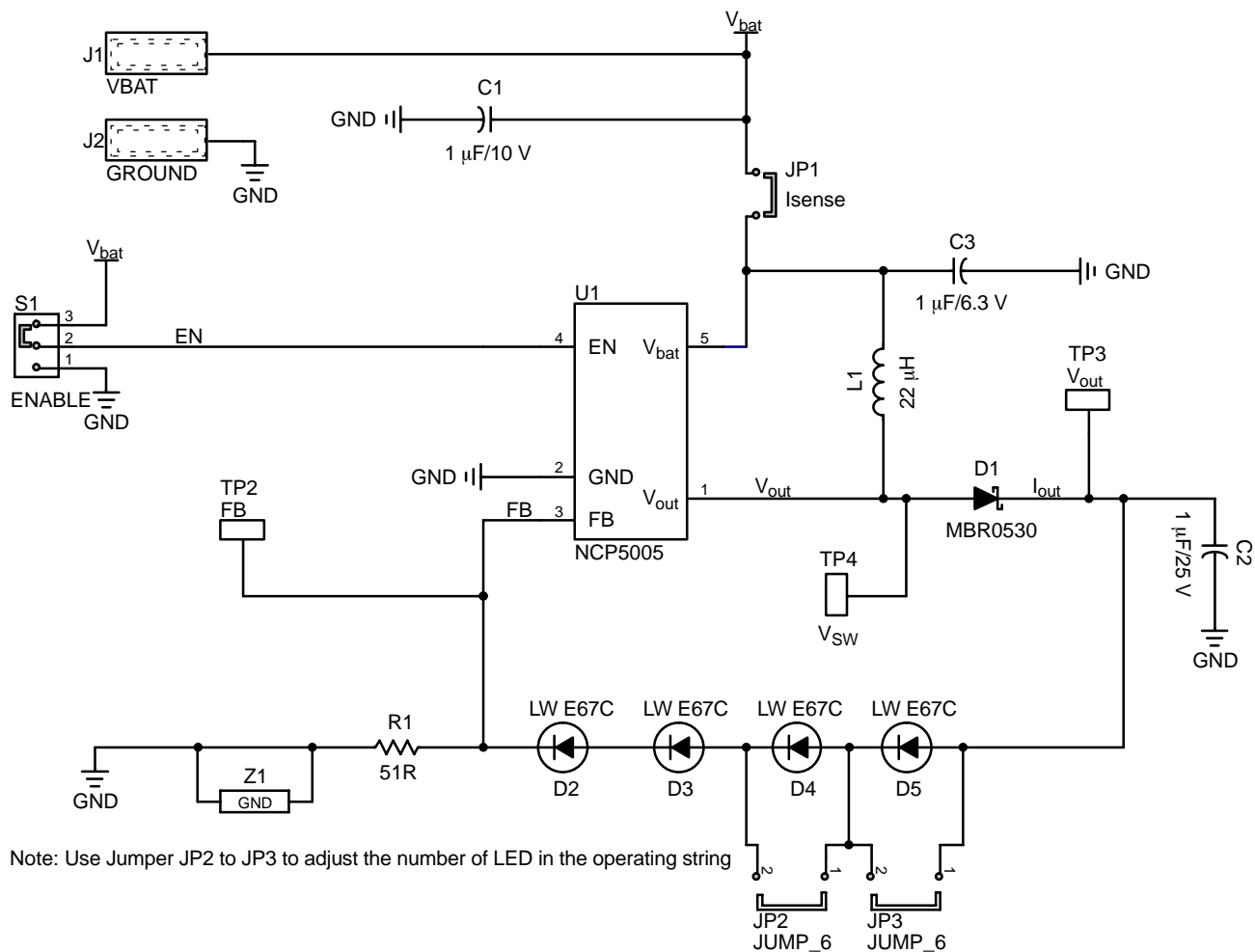

Figure 37. NCP5005 Demo Board Schematic Diagram

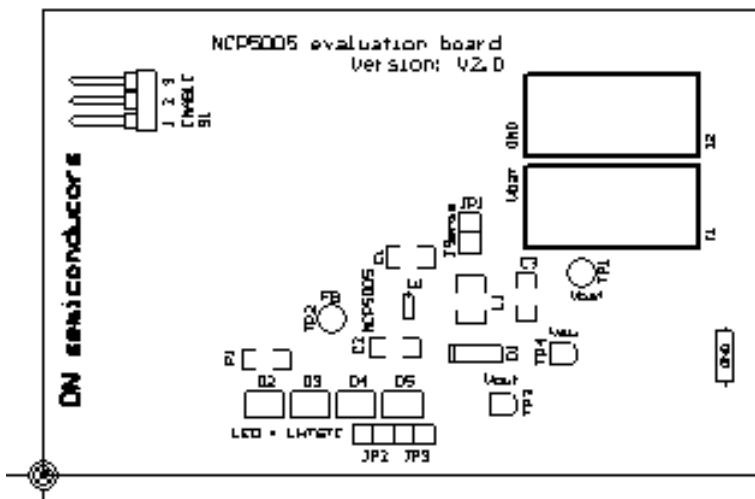

Figure 38. NCP5005 Demo Board Top Silkscreen

NCP5005

FIGURES INDEX

Figure 1: Typical Application	2
Figure 2: Block Diagram	2
Figure 3: Basic DC/DC Converter Structure	5
Figure 4: Basic DC/DC Operation	6
Figure 5: Maximum Output Power as a Function of the Battery Supply Voltage	7
Figure 6: Typical Inductor Peak Current as a Function of V_{bat} Voltage	7
Figure 7: Maximum Output Current as a Function of V_{bat}	7
Figure 8: Output Current Feedback	8
Figure 9: Basic Schematic Diagram	8
Figure 10: Overall Efficiency vs. Power Supply @ $I_{out} = 4.0$ mA, $L = 22$ μ H	9
Figure 11: Overall Efficiency vs. Power Supply @ $I_{out} = 10$ mA, $L = 22$ μ H	9
Figure 12: Overall Efficiency vs. Power Supply @ $I_{out} = 15$ mA, $L = 22$ μ H	9
Figure 13: Overall Efficiency vs. Power Supply @ $I_{out} = 20$ mA, $L = 22$ μ H	9
Figure 14: Overall Efficiency vs. Power Supply @ $I_{out} = 40$ mA, $L = 22$ μ H	10
Figure 15: Feedback Voltage Stability	10
Figure 16: Feedback Voltage Variation	10
Figure 17: Standby Current	10
Figure 18: Typical Operating Frequency	10
Figure 19: Overvoltage Protection	10
Figure 20: Typical Power Up Response	11
Figure 21: Typical Start-Up Inductor Current and Output Voltage	11
Figure 22: Typical Inductor Current	12
Figure 23: Typical Output Voltage Ripple	12
Figure 24: Typical Output Peak Voltage	13
Figure 25: Efficiency as a Function of V_{bat} and Inductor ESR	13
Figure 26: Noise Returned to the Battery	14
Figure 27: Relative EMI Over 100 kHz–30 MHz Bandwidth	14
Figure 28: Basic DC Current Mode Operation with Analog Feedback	15
Figure 29: Basic DC Current Mode Operation with PWM Control	16
Figure 30: Operation with Analog PWM, $f = 10$ kHz, DC = 25%	16
Figure 31: Typical Semi-Pulsed Mode of Operation	17
Figure 32: Operation @ PWM = 10 kHz, DC = 10%	17
Figure 33: Operation @ PWM = 10 kHz, DC = 25%	18
Figure 34: Magnified View of Operation @ PWM = 10 kHz, DC = 25%	18
Figure 35: Output Current as a Function of the Operating Conditions	19
Figure 36: Examples of Possible LED Arrangements	20
Figure 37: NCP5005 Demo Board Schematic Diagram	21
Figure 38: NCP5005 Demo Board Top Silkscreen	21

NOTE CAPTIONS INDEX

Note 1: This device series contains ESD protection and exceeds the following tests	4
Note 2: The maximum package power dissipation limit must not be exceeded	4
Note 3: Latch-up current maximum rating: ± 100 mA per JEDEC standard: JESD78	4
Note 4: Moisture Sensivity Level (MSL): 1 per IPC/JEDEC standard: J-STD-020A	4
Note 5: The overall tolerance depends upon the accuracy of the external resistor	5

ABBREVIATIONS

EN	Enable
FB	Feed Back
POR	Power On Reset: Internal pulse to reset the chip when the power supply is applied

NCP5005

PACKAGE DIMENSIONS

TSOP-5
SN SUFFIX
CASE 483-02
ISSUE C

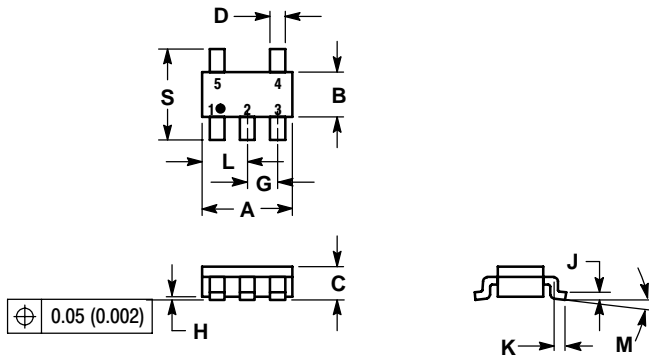

NOTES:

1. DIMENSIONING AND TOLERANCING PER ANSI Y14.5M, 1982.
2. CONTROLLING DIMENSION: MILLIMETER.
3. MAXIMUM LEAD THICKNESS INCLUDES LEAD FINISH THICKNESS. MINIMUM LEAD THICKNESS IS THE MINIMUM THICKNESS OF BASE MATERIAL.
4. A AND B DIMENSIONS DO NOT INCLUDE MOLD FLASH, PROTRUSIONS, OR GATE BURRS.

DIM	MILLIMETERS		INCHES	
	MIN	MAX	MIN	MAX
A	2.90	3.10	0.1142	0.1220
B	1.30	1.70	0.0512	0.0669
C	0.90	1.10	0.0354	0.0433
D	0.25	0.50	0.0098	0.0197
G	0.85	1.05	0.0335	0.0413
H	0.013	0.100	0.0005	0.0040
J	0.10	0.26	0.0040	0.0102
K	0.20	0.60	0.0079	0.0236
L	1.25	1.55	0.0493	0.0610
M	0	10	0	10
S	2.50	3.00	0.0985	0.1181

SOLDERING FOOTPRINT*

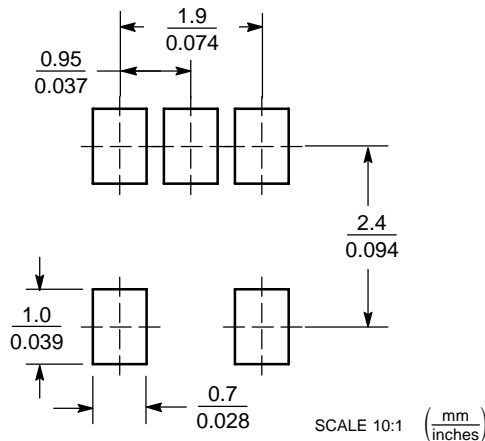

*For additional information on our Pb-Free strategy and soldering details, please download the ON Semiconductor Soldering and Mounting Techniques Reference Manual, SOLDERRM/D.

ON Semiconductor and are registered trademarks of Semiconductor Components Industries, LLC (SCILLC). SCILLC reserves the right to make changes without further notice to any products herein. SCILLC makes no warranty, representation or guarantee regarding the suitability of its products for any particular purpose, nor does SCILLC assume any liability arising out of the application or use of any product or circuit, and specifically disclaims any and all liability, including without limitation special, consequential or incidental damages. "Typical" parameters which may be provided in SCILLC data sheets and/or specifications can and do vary in different applications and actual performance may vary over time. All operating parameters, including "Typicals" must be validated for each customer application by customer's technical experts. SCILLC does not convey any license under its patent rights nor the rights of others. SCILLC products are not designed, intended, or authorized for use as components in systems intended for surgical implant into the body, or other applications intended to support or sustain life, or for any other application in which the failure of the SCILLC product could create a situation where personal injury or death may occur. Should Buyer purchase or use SCILLC products for any such unintended or unauthorized application, Buyer shall indemnify and hold SCILLC and its officers, employees, subsidiaries, affiliates, and distributors harmless against all claims, costs, damages, and expenses, and reasonable attorney fees arising out of, directly or indirectly, any claim of personal injury or death associated with such unintended or unauthorized use, even if such claim alleges that SCILLC was negligent regarding the design or manufacture of the part. SCILLC is an Equal Opportunity/Affirmative Action Employer. This literature is subject to all applicable copyright laws and is not for resale in any manner.

PUBLICATION ORDERING INFORMATION

LITERATURE FULFILLMENT:

Literature Distribution Center for ON Semiconductor
P.O. Box 61312, Phoenix, Arizona 85082-1312 USA
Phone: 480-829-7710 or 800-344-3860 Toll Free USA/Canada
Fax: 480-829-7709 or 800-344-3867 Toll Free USA/Canada
Email: orderlit@onsemi.com

N. American Technical Support: 800-282-9855 Toll Free
USA/Canada

Japan: ON Semiconductor, Japan Customer Focus Center
2-9-1 Kamimeguro, Meguro-ku, Tokyo, Japan 153-0051
Phone: 81-3-5773-3850

ON Semiconductor Website: <http://onsemi.com>

Order Literature: <http://www.onsemi.com/litorder>

For additional information, please contact your local Sales Representative.