



January 2006

LMH0002

SMPTE 292M / 259M Serial Digital Cable Driver

General Description

The LMH0002 SMPTE 292M / 259M serial digital cable driver is a monolithic, high-speed cable driver designed for use in SMPTE 292M / 259M serial digital video and ITU-T G.703 serial digital data transmission applications. The LMH0002 drives 75Ω transmission lines (Belden 8281, Belden 1694A or equivalent) at data rates up to 1.485 Gbps.

The LMH0002 provides two selectable slew rates for SMPTE 259M and SMPTE 292M compliance. The output voltage swing is adjustable via a single external resistor.

The LMH0002 is powered from a single 3.3V supply. Power consumption is typically 125mW in SD mode and 149mW in HD mode.

Features

- SMPTE 292M, SMPTE 344M and SMPTE 259M compliant
- Data rates to 1.485 Gbps
- Differential input
- 75Ω differential output
- Selectable slew rate
- Adjustable output amplitude
- Single 3.3V supply operation
- Operating temperature range: Commercial 0°C to +70°C (LMH0002MA) or Industrial -40°C to +85°C (LMH0002TMA)
- Typical power consumption: 125mW in SD mode and 149mW in HD mode
- Replaces the GS1528 and GS1528A

Applications

- SMPTE 292M, SMPTE 344M, and SMPTE 259M serial digital interfaces
- Sonet/SDH and ATM interfaces
- Digital routers and switches
- Distribution amplifiers
- Buffer applications
- Set top boxes
- Security cameras

Typical Application

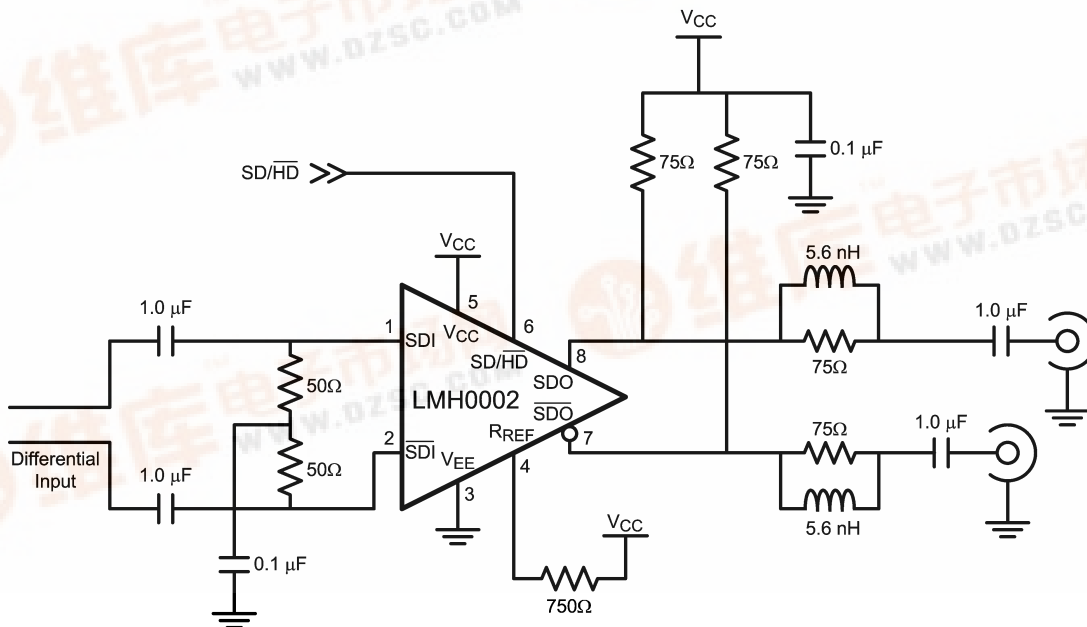

20176102

LMH0002 SMPTE 292M / 259M Serial Digital Cable Driver



Absolute Maximum Ratings (Note 1)

Supply Voltage:	-0.5V to 3.6V
Input Voltage (all inputs)	-0.3V to $V_{CC}+0.3V$
Output Current	28mA
Storage Temperature Range	-65°C to +150°C
Junction Temperature	+150°C
Lead Temperature (Soldering 4 Sec)	+260°C
Package Thermal Resistance	
θ_{JA} 8-pin SOIC	+125°C/W
θ_{JC} 8-pin SOIC	+105°C/W

ESD Rating (HBM)

5kV

ESD Rating (MM)

250V

Recommended Operating Conditions

Supply Voltage ($V_{CC} - V_{EE}$):	3.3V \pm 5%
Operating Free Air Temperature (T_A)	
LMH0002MA	0°C to +70°C
LMH0002TMA	-40°C to +85°C

DC Electrical Characteristics

Over Supply Voltage and Operating Temperature ranges, unless otherwise specified (Notes 2, 3).

Symbol	Parameter	Conditions	Reference	Min	Typ	Max	Units
V_{CMIN}	Input Common Mode Voltage		SDI, \overline{SDI}	1.6 + $V_{SDI}/2$		$V_{CC} -$ $V_{SDI}/2$	V
V_{SDI}	Input Voltage Swing	Differential		100		2000	mV _{P-P}
V_{CMOUT}	Output Common Mode Voltage		SDO, \overline{SDO}		$V_{CC} -$ V_{SDO}		V
V_{SDO}	Output Voltage Swing	Single-ended, 75 Ω load, $R_{REF} = 750\Omega$ 1%		750	800	850	mV _{P-P}
		Single-ended, 75 Ω load, $R_{REF} = 590\Omega$ 1%		900	1000	1100	mV _{P-P}
	SD/ \overline{HD} Input Voltage	Min for SD	SD/ \overline{HD}	2.4			V
		Max for HD				0.8	V
	SD/ \overline{HD} Input Current				3.7		μ A
I_{CC}	Supply Current	SD/ $\overline{HD} = 0$, (Note 5)			45	49	mA
		SD/ $\overline{HD} = 1$, (Note 5)			38	43	mA

AC Electrical Characteristics

Over Supply Voltage and Operating Temperature ranges, unless otherwise specified (Note 3).

Symbol	Parameter	Conditions	Reference	Min	Typ	Max	Units
DR_{SDI}	Input Data Rate	(Note 4)	SDI, \overline{SDI}			1485	Mbps
t_{jit}	Additive Jitter	1.485 Gbps	SDO, \overline{SDO}		26		ps _{P-P}
		270 Mbps			18		ps _{P-P}
t_r, t_f	Output Rise Time, Fall Time	SD/ $\overline{HD} = 0$, 20% – 80%, (Note 6)			120	220	ps
		SD/ $\overline{HD} = 1$, 20% – 80%		400	560	800	ps
	Mismatch in Rise/Fall Time	(Note 4)				30	ps
t_{OS}	Output Overshoot	(Note 4)				8	%
RL_{SDO}	Output Return Loss	(Note 7)		15	20		dB

Note 1: "Absolute Maximum Ratings" are those parameter values beyond which the life and operation of the device cannot be guaranteed. The stating herein of these maximums shall not be construed to imply that the device can or should be operated at or beyond these values. The table of "Electrical Characteristics" specifies acceptable device operating conditions.

Note 2: Current flow into device pins is defined as positive. Current flow out of device pins is defined as negative. All voltages are stated referenced to $V_{EE} = 0$ Volts.

Note 3: Typical values are stated for $V_{CC} = +3.3V$ and $T_A = +25^\circ C$.

Note 4: Specification is guaranteed by characterization.

Note 5: Maximum I_{CC} is measured at $V_{CC} = +3.465V$ and $T_A = +70^\circ C$.

Note 6: Specification is guaranteed by characterization and verified by test.

Note 7: Output return loss is dependent on board design. The LMH0002 meets this specification on the SD002 evaluation board from 5MHz to 1.5GHz.

Connection Diagram

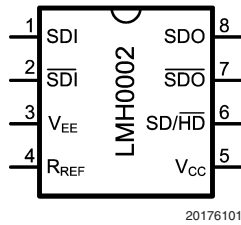

20176101

8-Pin SOIC

Order Number LMH0002MA or LMH0002TMA
See NS Package Number M08A

Pin Descriptions

Pin #	Name	Description
1	SDI	Serial data true input.
2	$\overline{\text{SDI}}$	Serial data complement input.
3	V_{EE}	Negative power supply (ground).
4	R_{REF}	Output driver level control. Connect a resistor to V_{CC} to set output voltage swing.
5	V_{CC}	Positive power supply (+3.3V).
6	$\overline{\text{SD/HD}}$	Output slew rate control. Output rise/fall time complies with SMPTE 292M when low and SMPTE 259M when high.
7	$\overline{\text{SDO}}$	Serial data complement output.
8	SDO	Serial data true output.

Device Operation

INPUT INTERFACING

The LMH0002 accepts either differential or single-ended input. The inputs are self-biased, allowing for simple AC or DC coupling. DC-coupled inputs must be kept within the specified common-mode range. SDI and $\overline{\text{SDI}}$ are self-biased at approximately 2.1V with $V_{CC} = 3.3\text{V}$. Figure 1 shows the differential input stage for SDI and $\overline{\text{SDI}}$.

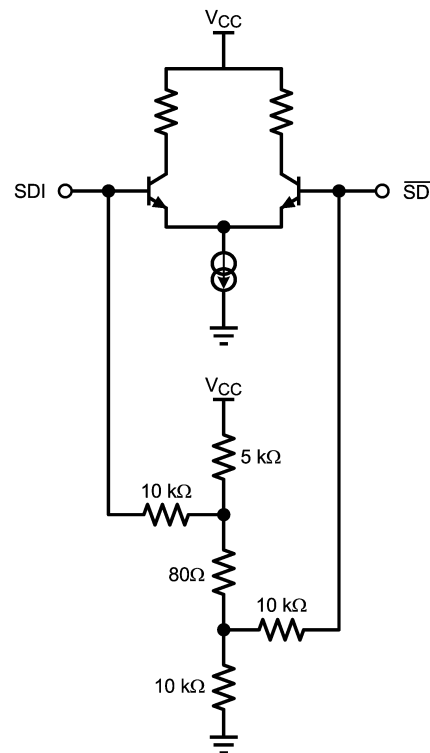

20176104

FIGURE 1. Differential Input Stage for SDI and $\overline{\text{SDI}}$.

Device Operation (Continued)

OUTPUT INTERFACING

The LMH0002 uses current mode outputs. Single-ended output levels are 800 mV_{P-P} into 75Ω AC-coupled coaxial cable (with R_{REF} = 750Ω). Output level is controlled by the value of the R_{REF} resistor connected between pin 4 and V_{CC}.

The R_{REF} resistor should be placed as close as possible to the R_{REF} pin. In addition, the copper in the plane layers below the R_{REF} network should be removed to minimize parasitic capacitance.

OUTPUT SLEW RATE CONTROL

The LMH0002 output rise and fall times are selectable for either SMPTE 259M or SMPTE 292M compliance via pin 6, SD/ $\overline{\text{HD}}$. For slower rise and fall times, or SMPTE 259M compliance, SD/ $\overline{\text{HD}}$ is set high. For faster rise and fall times, or SMPTE 292M compliance, SD/ $\overline{\text{HD}}$ is set low.

REPLACING THE GENNUM GS1528

The LMH0002 is form-fit-function compatible with the Gennum GS1528 and GS1528A.

Physical Dimensions inches (millimeters) unless otherwise noted

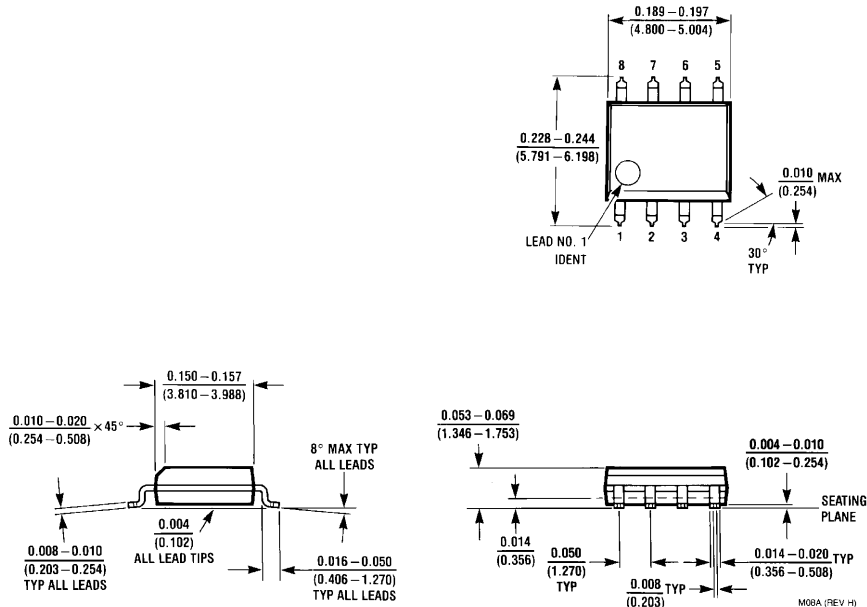

8-Pin SOIC
Order Number LMH0002MA or LMH0002TMA
NS Package Number M08A

National does not assume any responsibility for use of any circuitry described, no circuit patent licenses are implied and National reserves the right at any time without notice to change said circuitry and specifications.

For the most current product information visit us at www.national.com.

LIFE SUPPORT POLICY

NATIONAL'S PRODUCTS ARE NOT AUTHORIZED FOR USE AS CRITICAL COMPONENTS IN LIFE SUPPORT DEVICES OR SYSTEMS WITHOUT THE EXPRESS WRITTEN APPROVAL OF THE PRESIDENT AND GENERAL COUNSEL OF NATIONAL SEMICONDUCTOR CORPORATION. As used herein:

1. Life support devices or systems are devices or systems which, (a) are intended for surgical implant into the body, or (b) support or sustain life, and whose failure to perform when properly used in accordance with instructions for use provided in the labeling, can be reasonably expected to result in a significant injury to the user.
2. A critical component is any component of a life support device or system whose failure to perform can be reasonably expected to cause the failure of the life support device or system, or to affect its safety or effectiveness.

BANNED SUBSTANCE COMPLIANCE

National Semiconductor manufactures products and uses packing materials that meet the provisions of the Customer Products Stewardship Specification (CSP-9-111C2) and the Banned Substances and Materials of Interest Specification (CSP-9-111S2) and contain no "Banned Substances" as defined in CSP-9-111S2.

Leadfree products are RoHS compliant.



National Semiconductor
Americas Customer
Support Center
 Email: new.feedback@nsc.com
 Tel: 1-800-272-9959

National Semiconductor
Europe Customer Support Center
 Fax: +49 (0) 180-530 85 86
 Email: europe.support@nsc.com
 Deutsch Tel: +49 (0) 69 9508 6208
 English Tel: +44 (0) 870 24 0 2171
 Français Tel: +33 (0) 1 41 91 8790

National Semiconductor
Asia Pacific Customer
Support Center
 Email: ap.support@nsc.com

National Semiconductor
Japan Customer Support Center
 Fax: 81-3-5639-7507
 Email: jpn.feedback@nsc.com
 Tel: 81-3-5639-7560