

## Low-Voltage, Single Supply, DPDT High Performance Analog Switch

The Intersil ISL43410 is a precision, bidirectional, analog switch configured as a double pole/double throw (DPDT) switch. The ISL43410 is designed to operate from a single +2V to +12V supply. It is equipped with an inhibit pin to simultaneously open all signal paths.

ON resistance is 115Ω with a +5V supply, 45Ω with a +12V supply, and 190Ω with a +3V supply. Each switch can handle rail to rail analog signals. The off-leakage current is only 1nA at 25°C or 2.5nA at 85°C. All digital inputs have 0.8V to 2.4V logic thresholds ensuring TTL/CMOS logic compatibility when using a single +5V supply. Some of the smallest packages are available, alleviating board space limitations, and making Intersil's newest line of low-voltage switches an ideal solution.

The ISL43410 is a DPDT, which is perfect for use in 2-to-1 multiplexer applications.

Table 1 summarizes the performance of this switch.

TABLE 1. FEATURES AT A GLANCE

CONFIGURATION	DPDT
12V R <sub>ON</sub>	45Ω
12V t <sub>ON</sub> /t <sub>OFF</sub>	25ns/24ns
4.5V R <sub>ON</sub>	115Ω
4.5V t <sub>ON</sub> /t <sub>OFF</sub>	60ns/30ns
3V R <sub>ON</sub>	190Ω
3V t <sub>ON</sub> /t <sub>OFF</sub>	120ns/45ns
Packages	10 Ld MSOP, 16 Ld QFN 3x3

### Related Literature

- Technical Brief TB363 "Guidelines for Handling and Processing Moisture Sensitive Surface Mount Devices (SMDs)"
- Application Note AN557 "Recommended Test Procedures for Analog Switches"
- Application Note AN520 "CMOS Analog Multiplexers and Switches; Specifications and Application Considerations."
- Application Note AN1034 "Analog Switch and Multiplexer Applications"

### Features

- Fully Specified at 3V, 5V, and 12V Supplies for 10% Tolerances
- ON Resistance (R<sub>ON</sub>), V<sub>S</sub> = 5V ..... 100Ω
- R<sub>ON</sub> Matching Between Channels ..... <2Ω
- Low Charge Injection ..... 3pC (Max)
- Single Supply Operation ..... +2V to +12V
- Low Power Consumption (P<sub>D</sub>) ..... <3μW
- Low Off Leakage Current ..... 2.5nA
- Fast Switching Action (V<sub>S</sub> = 5V)
  - t<sub>ON</sub> ..... 60ns
  - t<sub>OFF</sub> ..... 30ns
- Guaranteed Break-Before-Make
- TTL, CMOS Compatible
- Available in 10 Ld MSOP and 16 Ld QFN Packages
- Pb-Free Plus Anneal Available (RoHS Compliant)

### Applications

- Battery Powered, Handheld, and Portable Equipment
- Communications Systems
  - Radios
  - Telecom Infrastructure
  - ADSL, VDSL Modems
- Test Equipment
  - Medical Ultrasound
  - Electrocardiograph
  - Magnetic Resonance Image
  - CT and PET Scanners (MRI)
  - ATE
- Audio and Video Switching
- Various Circuits
  - +3V/+5V DACs and ADCs
  - Sample and Hold Circuits
  - Operational Amplifier Gain Switching Networks
  - High Frequency Analog Switching
  - High Speed Multiplexing
  - Integrator Reset Circuits



# ISL43410

## Pinouts (Note 1)

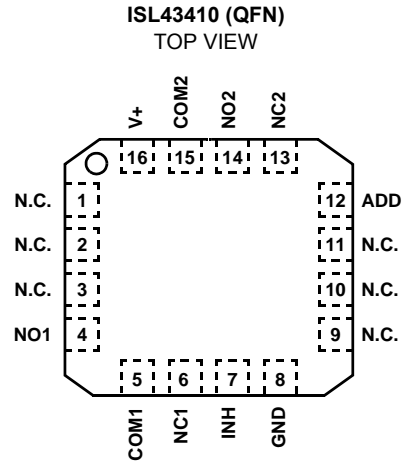
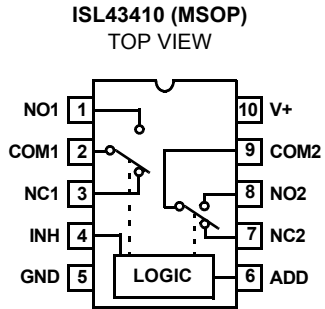

NOTE:

1. Switches Shown for Logic "0" Inputs.

## Truth Table

ISL43410

INH	ADD	SWITCH ON
1	X	NONE
0	0	NCX
0	1	NOX

NOTE: Logic "0"  $\leq 0.8V$ . Logic "1"  $\geq 2.4V$ , with  $V_S$  between 3.3V and 11V.

## Pin Descriptions

PIN	FUNCTION
V+	System Power Supply Input (+2V to +12V)
GND	Ground Connection
INH	Digital Control Input. Connect to GND for Normal Operation. Connect to V+ to turn all switches off.
COM	Analog Switch Common Pin
NO	Analog Switch Normally Open Pin
NC	Analog Switch Normally Closed Pin
ADD	Address Input Pin
N.C.	No Internal Connection

## Ordering Information

PART NO.	PART MARKING	TEMP. RANGE (°C)	PACKAGE	PKG. DWG. #
ISL43410IU	3410	-40 to 85	10 Ld MSOP	M10.118
ISL43410IU-T	3410	-40 to 85	10 Ld MSOP Tape & Reel	M10.118
ISL43410IUZ (Note)	3410Z	-40 to 85	10 Ld MSOP (Pb-free)	M10.118
ISL43410IUZ-T (Note)	3410Z	-40 to 85	10 Ld MSOP Tape & Reel (Pb-free)	M10.118
ISL43410IR	410I	-40 to 85	16 Ld QFN	L16.3X3
ISL43410IR-T	410I	-40 to 85	16 Ld QFN Tape & Reel	L16.3X3
ISL43410IRZ (Note)	341Z	-40 to 85	16 Ld QFN (Pb-free)	L16.3X3
ISL43410IRZ-T (Note)	341Z	-40 to 85	16 Ld QFN Tape & Reel (Pb-free)	L16.3X3

NOTE: Intersil Pb-free plus anneal products employ special Pb-free material sets; molding compounds/die attach materials and 100% matte tin plate termination finish, which are RoHS compliant and compatible with both SnPb and Pb-free soldering operations. Intersil Pb-free products are MSL classified at Pb-free peak reflow temperatures that meet or exceed the Pb-free requirements of IPC/JEDEC J STD-020.

# ISL43410

## Absolute Maximum Ratings

V+ to GND	-0.3 to 15V
Input Voltages	
INH, NO, NC, ADD (Note 2)	-0.3 to ((V+) + 0.3V)
Output Voltages	
COM (Note 2)	-0.3 to ((V+) + 0.3V)
Continuous Current (Any Terminal)	30mA
Peak Current NO, NC, or COM (Pulsed 1ms, 10% Duty Cycle, Max)	40mA

## Thermal Information

Thermal Resistance (Typical)	$\theta_{JA}$ (°C/W)
10 Ld MSOP Package (Note 3)	190
16 Ld QFN Package (Note 4)	62
Maximum Junction Temperature (Plastic Package)	150°C
Moisture Sensitivity (See Technical Brief TB363)	
All Packages	Level 1
Maximum Storage Temperature Range	-65°C to 150°C
Maximum Lead Temperature (Soldering 10s)	300°C (MSOP - Lead Tips Only)

## Operating Conditions

Temperature Range	
ISL43410IX	-40°C to 85°C

**CAUTION:** Stresses above those listed in "Absolute Maximum Ratings" may cause permanent damage to the device. This is a stress only rating and operation of the device at these or any other conditions above those indicated in the operational sections of this specification is not implied.

### NOTES:

- Signals on NC, NO, COM, ADD, or INH exceeding V+ or GND are clamped by internal diodes. Limit forward diode current to maximum current ratings.
- $\theta_{JA}$  is measured with the component mounted on a low effective thermal conductivity test board in free air. See Tech Brief TB379 for details.
- $\theta_{JA}$  is measured with the component mounted on a high effective thermal conductivity test board in free air. See Tech Brief TB379 for details.

## Electrical Specifications +5V Supply

Test Conditions: V+ = +4.5V to +5.5V, GND = 0V,  $V_{INH} = 2.4V$ ,  $V_{INL} = 0.8V$  (Note 5), Unless Otherwise Specified

PARAMETER	TEST CONDITIONS	TEMP (°C)	(NOTE 6) MIN	TYP	(NOTE 6) MAX	UNITS
<b>ANALOG SWITCH CHARACTERISTICS</b>						
Analog Signal Range, $V_{ANALOG}$		Full	0	-	V+	V
ON Resistance, $R_{ON}$	V+ = 4.5V, $I_{COM} = 1.0mA$ , $V_{NO}$ or $V_{NC} = 3.5V$ , (See Figure 5)	25	-	115	125	$\Omega$
		Full	-	-	150	$\Omega$
$R_{ON}$ Matching Between Channels, $\Delta R_{ON}$	V+ = 4.5V, $I_{COM} = 1.0mA$ , $V_{NO}$ or $V_{NC} = 3.5V$ , (Note 8)	25	-	1	3	$\Omega$
		Full	-	-	5	$\Omega$
$R_{ON}$ Flatness, $R_{FLAT(ON)}$	V+ = 5.5V, $I_{COM} = 1.0mA$ , $V_{NO}$ or $V_{NC} = 1.5V, 2.5V, 3.5V$ , (Note 9)	25	-	12	13	$\Omega$
		Full	-	13	18	$\Omega$
NO or NC OFF Leakage Current, $I_{NO(OFF)}$ or $I_{NC(OFF)}$	V+ = 5.5V, $V_{COM} = 1V, 4.5V$ , $V_{NO}$ or $V_{NC} = 4.5V, 1V$ , (Note 7)	25	-1	-	1	nA
		Full	-2.5	-	2.5	nA
COM OFF Leakage Current, $I_{COM(OFF)}$	V+ = 5.5V, $V_{COM} = 4.5V, 1V$ , $V_{NO}$ or $V_{NC} = 1V, 4.5V$ , (Note 7)	25	-1	-	1	nA
		Full	-2.5	-	2.5	nA
COM ON Leakage Current, $I_{COM(ON)}$	V+ = 5.5V, $V_{COM} = 1V, 4.5V$ , or $V_{NO}$ or $V_{NC} = 1V, 4.5V$ , or Floating, (Note 7)	25	-1	-	1	nA
		Full	-5	-	5	nA
<b>DIGITAL INPUT CHARACTERISTICS</b>						
Input Voltage High, $V_{INH}$		Full	2.4	1.4	-	V
Input Voltage Low, $V_{INL}$		Full	-	1.3	0.8	V
Input Current, $I_{INH}$ , $I_{INL}$	V+ = 5.5V, $V_{IN} = 0V$ or V+	Full	-0.5	-	0.5	$\mu A$
<b>DYNAMIC CHARACTERISTICS</b>						
Inhibit Turn-ON Time, $t_{ON}$	V+ = 4.5V, $V_{NO}$ or $V_{NC} = 3V$ , $R_L = 300\Omega$ , $C_L = 35pF$ , $V_{IN} = 0$ to 3, (See Figure 1)	25	-	60	65	ns
		Full	-	-	80	ns
Inhibit Turn-OFF Time, $t_{OFF}$	V+ = 4.5V, $V_{NO}$ or $V_{NC} = 3V$ , $R_L = 300\Omega$ , $C_L = 35pF$ , $V_{IN} = 0$ to 3, (See Figure 1)	25	-	30	35	ns
		Full	-	-	40	ns
Address Transition Time, $t_{TRANS}$	V+ = 4.5V, $V_{NO}$ or $V_{NC} = 3V$ , $R_L = 300\Omega$ , $C_L = 35pF$ , $V_{IN} = 0$ to 3, (See Figure 1)	25	-	61	70	ns
		Full	-	-	85	ns
Break-Before-Make Time Delay, $t_D$	V+ = 5.5V, $R_L = 300\Omega$ , $C_L = 35pF$ , $V_{NO} = V_{NC} = 3V$ , $V_{IN} = 0$ to 3, (See Figure 3)	Full	5	16	-	ns

## ISL43410

### Electrical Specifications +5V Supply Test Conditions: V+ = +4.5V to +5.5V, GND = 0V, V<sub>INH</sub> = 2.4V, V<sub>INL</sub> = 0.8V (Note 5), Unless Otherwise Specified (Continued)

PARAMETER	TEST CONDITIONS	TEMP (°C)	(NOTE 6) MIN	TYP	(NOTE 6) MAX	UNITS
Charge Injection, Q	C <sub>L</sub> = 1.0nF, V <sub>G</sub> = 0V, R <sub>G</sub> = 0Ω, (See Figure 2)	25	-	0.3	1	pC
OFF Isolation	R <sub>L</sub> = 50Ω, C <sub>L</sub> = 5pF, f = 1MHz, (See Figure 4)	25	-	75	-	dB
Crosstalk (Channel-to-Channel)	R <sub>L</sub> = 50Ω, C <sub>L</sub> = 5pF, f = 1MHz, (See Figure 6)	25	-	-85	-	dB
NO or NC OFF Capacitance, C <sub>OFF</sub>	f = 1MHz, V <sub>NO</sub> or V <sub>NC</sub> = V <sub>COM</sub> = 0V, (See Figure 7)	25	-	4	-	pF
COM OFF Capacitance, C <sub>COM(OFF)</sub>	f = 1MHz, V <sub>NO</sub> or V <sub>NC</sub> = V <sub>COM</sub> = 0V, (See Figure 7)	25	-	6	-	pF
COM ON Capacitance, C <sub>COM(ON)</sub>	f = 1MHz, V <sub>NO</sub> or V <sub>NC</sub> = V <sub>COM</sub> = 0V, (See Figure 7)	25	-	12	-	pF
<b>POWER SUPPLY CHARACTERISTICS</b>						
Power Supply Range		Full	2	-	12	V
Positive Supply Current, I+	V+ = 5.5V, V <sub>IN</sub> = 0V or V+, all channels on or off	Full	-1	0.0001	1	μA

**NOTES:**

5. V<sub>IN</sub> = input voltage to perform proper function.
6. The algebraic convention, whereby the most negative value is a minimum and the most positive a maximum, is used in this data sheet.
7. Leakage parameter is 100% tested at high temp, and guaranteed by correlation at 25°C.
8. ΔR<sub>ON</sub> = R<sub>ON</sub> (MAX) - R<sub>ON</sub> (MIN).
9. Flatness is defined as the difference between the maximum and minimum value of on-resistance over the specified analog signal range.

### Electrical Specifications +3V Supply Test Conditions: V+ = +2.7V to +3.6V, GND = 0V, V<sub>AH</sub> = 2.4V, V<sub>AL</sub> = 0.8V (Note 5), Unless Otherwise Specified

PARAMETER	TEST CONDITIONS	TEMP (°C)	(NOTE 6) MIN	TYP	(NOTE 6) MAX	UNITS
<b>ANALOG SWITCH CHARACTERISTICS</b>						
Analog Signal Range, V <sub>ANALOG</sub>		Full	0	-	V+	V
ON Resistance, R <sub>ON</sub>	V+ = 3.0V, I <sub>COM</sub> = 1.0mA, V <sub>NO</sub> or V <sub>NC</sub> = 1.5V, (See Figure 5)	25	-	190	220	Ω
		Full	-	-	250	Ω
R <sub>ON</sub> Matching Between Channels, ΔR <sub>ON</sub>	V+ = 3.0V, I <sub>COM</sub> = 1.0mA, V <sub>NO</sub> or V <sub>NC</sub> = 1.5V, (Note 8)	25	-	1	3	Ω
		Full	-	-	5	Ω
R <sub>ON</sub> Flatness, R <sub>FLAT(ON)</sub>	V+ = 3.0V, I <sub>COM</sub> = 1.0mA, V <sub>NO</sub> or V <sub>NC</sub> = 0.5V, 1.5V, (Note 9)	25	-	48	90	Ω
		Full	-	-	90	Ω
NO or NC OFF Leakage Current, I <sub>NO(OFF)</sub> or I <sub>NC(OFF)</sub>	V+ = 3.6V, V <sub>COM</sub> = 1V, 3V, V <sub>NO</sub> or V <sub>NC</sub> = 3V, 1V, (Note 7)	25	-1	-	1	nA
		Full	-2.5	-	2.5	nA
COM OFF Leakage Current, I <sub>COM(OFF)</sub>	V+ = 3.6V, V <sub>COM</sub> = 3V, 1V, V <sub>NO</sub> or V <sub>NC</sub> = 1V, 3V, (Note 7)	25	-1	-	1	nA
		Full	-2.5	-	2.5	nA
COM ON Leakage Current, I <sub>COM(ON)</sub>	V+ = 3.6V, V <sub>COM</sub> = 1V, 3V, or V <sub>NO</sub> or V <sub>NC</sub> = 1V, 3V, or floating, (Note 7)	25	-1	-	1	nA
		Full	-5	-	5	nA
<b>DIGITAL INPUT CHARACTERISTICS</b>						
Input Voltage High, V <sub>INH</sub>		Full	2.0	1.0	-	V
Input Voltage Low, V <sub>INL</sub>		Full	-	0.8	0.5	V
Input Current, I <sub>INH</sub> , I <sub>INL</sub>	V+ = 3.6V, V <sub>IN</sub> = 0V or V+	Full	-0.5	-	0.5	μA
<b>DYNAMIC CHARACTERISTICS</b>						
Inhibit Turn-ON Time, t <sub>ON</sub>	V+ = 2.7V, V <sub>NO</sub> or V <sub>NC</sub> = 1.5V, R <sub>L</sub> = 300Ω, C <sub>L</sub> = 35pF, V <sub>IN</sub> = 0 to 3, (See Figure 1)	25	-	144	155	ns
		Full	-	-	175	ns
Inhibit Turn-OFF Time, t <sub>OFF</sub>	V+ = 2.7V, V <sub>NO</sub> or V <sub>NC</sub> = 1.5V, R <sub>L</sub> = 300Ω, C <sub>L</sub> = 35pF, V <sub>IN</sub> = 0 to 3, (See Figure 1)	25	-	53	60	ns
		Full	-	-	65	ns
Address Transition Time, t <sub>TRANS</sub>	V+ = 2.7V, V <sub>NO</sub> or V <sub>NC</sub> = 1.5V, R <sub>L</sub> = 300Ω, C <sub>L</sub> = 35pF, V <sub>IN</sub> = 0 to 3, (See Figure 1)	25	-	145	160	ns
		Full	-	-	190	ns
Break-Before-Make Time Delay, t <sub>D</sub>	V+ = 3.6V, R <sub>L</sub> = 300Ω, C <sub>L</sub> = 35pF, V <sub>NO</sub> or V <sub>NC</sub> = 1.5V, V <sub>IN</sub> = 0 to 3, (See Figure 3)	Full	15	35	-	ns

# ISL43410

**Electrical Specifications +3V Supply** Test Conditions:  $V_+ = +2.7V$  to  $+3.6V$ ,  $GND = 0V$ ,  $V_{AH} = 2.4V$ ,  $V_{AL} = 0.8V$  (Note 5), Unless Otherwise Specified **(Continued)**

PARAMETER	TEST CONDITIONS	TEMP (°C)	(NOTE 6) MIN	TYP	(NOTE 6) MAX	UNITS
Charge Injection, Q	$C_L = 1.0nF$ , $V_G = 0V$ , $R_G = 0\Omega$ , (See Figure 2)	25	-	0.5	1	pC
OFF Isolation	$R_L = 50\Omega$ , $C_L = 5pF$ , $f = 1MHz$ , (See Figure 4)	25	-	75	-	dB
Crosstalk (Channel-to-Channel)	$R_L = 50\Omega$ , $C_L = 5pF$ , $f = 1MHz$ , (See Figure 6)	25	-	-85	-	dB
NO or NC OFF Capacitance, $C_{OFF}$	$f = 1MHz$ , $V_{NO}$ or $V_{NC} = V_{COM} = 0V$ , (See Figure 7)	25	-	4	-	pF
COM OFF Capacitance, $C_{COM(OFF)}$	$f = 1MHz$ , $V_{NO}$ or $V_{NC} = V_{COM} = 0V$ , (See Figure 7)	25	-	6	-	pF
COM ON Capacitance, $C_{COM(ON)}$	$f = 1MHz$ , $V_{NO}$ or $V_{NC} = V_{COM} = 0V$ , (See Figure 7)	25	-	12	-	pF
<b>POWER SUPPLY CHARACTERISTICS</b>						
Positive Supply Current, $I_+$	$V_+ = 3.6V$ , $V_{IN} = 0V$ or $V_+$ , all channels on or off	Full	-1	0.0001	1	$\mu A$

**Electrical Specifications + 12V Supply** Test Conditions:  $V_+ = +10.8V$  to  $+13.2V$ ,  $GND = 0V$ ,  $V_{INH} = 4V$ ,  $V_{INL} = 0.8V$  (Note 5), Unless Otherwise Specified

PARAMETER	TEST CONDITIONS	TEMP (°C)	(NOTE 6) MIN	TYP	(NOTE 6) MAX	UNITS
<b>ANALOG SWITCH CHARACTERISTICS</b>						
Analog Signal Range, $V_{ANALOG}$		Full	0	-	$V_+$	V
ON Resistance, $R_{ON}$	$V_+ = 12.0V$ , $I_{COM} = 1.0mA$ , $V_{NO}$ or $V_{NC} = 9V$ , (See Figure 5)	25	-	45	50	$\Omega$
		Full	-	-	70	$\Omega$
$R_{ON}$ Matching Between Channels, $\Delta R_{ON}$	$V_+ = 12.0V$ , $I_{COM} = 1.0mA$ , $V_{NO}$ or $V_{NC} = 9V$ , (Note 8)	25	-	0.5	3	$\Omega$
		Full	-	-	5	$\Omega$
$R_{ON}$ Flatness, $R_{FLAT(ON)}$	$V_+ = 13.2V$ , $I_{COM} = 1.0mA$ , $V_{NO}$ or $V_{NC} = 3V, 6V, 9V$ , (Note 9)	25	-	5	6	$\Omega$
		Full	-	-	10	$\Omega$
NO or NC OFF Leakage Current, $I_{NO(OFF)}$ or $I_{NC(OFF)}$	$V_+ = 13.0V$ , $V_{COM} = 1V, 12V$ , $V_{NO}$ or $V_{NC} = 12V, 1V$ , (Note 7)	25	-1	-	1	nA
		Full	-2.5	-	2.5	nA
COM OFF Leakage Current, $I_{COM(OFF)}$	$V_+ = 13.0V$ , $V_{COM} = 12V, 1V$ , $V_{NO}$ or $V_{NC} = 1V, 12V$ , (Note 7)	25	-1	-	1	nA
		Full	-2.5	-	2.5	nA
COM ON Leakage Current, $I_{COM(ON)}$	$V_+ = 13.0V$ , $V_{COM} = 1V, 12V$ , $V_{NO}$ or $V_{NC} = 1V, 12V$ , or floating, (Note 7)	25	-1	-	1	nA
		Full	-5	-	5	nA
<b>DIGITAL INPUT CHARACTERISTICS</b>						
Input Voltage High, $V_{INH}$		Full	2.9	2.5	-	V
Input Voltage Low, $V_{INL}$		Full	-	2.3	0.8	V
Input Current, $I_{INH}$ , $I_{INL}$	$V_+ = 13V$ , $V_{IN} = 0V$ or $V_+$	Full	-0.5	-	0.5	$\mu A$
<b>DYNAMIC CHARACTERISTICS</b>						
Inhibit Turn-ON Time, $t_{ON}$	$V_+ = 10.8V$ , $V_{NO}$ or $V_{NC} = 10V$ , $R_L = 300\Omega$ , $C_L = 35pF$ , $V_{IN} = 0$ to 4, (See Figure 1)	25	-	25	30	ns
		Full	-	-	35	ns
Inhibit Turn-OFF Time, $t_{OFF}$	$V_+ = 10.8V$ , $V_{NO}$ or $V_{NC} = 10V$ , $R_L = 300\Omega$ , $C_L = 35pF$ , $V_{IN} = 0$ to 4, (See Figure 1)	25	-	24	28	ns
		Full	-	-	30	ns
Address Transition Time, $t_{TRANS}$	$V_+ = 10.8V$ , $V_{NO}$ or $V_{NC} = 10V$ , $R_L = 300\Omega$ , $C_L = 35pF$ , $V_{IN} = 0$ to 4, (See Figure 1)	25	-	35	50	ns
		Full	-	-	55	ns
Break-Before-Make Time Delay, $t_D$	$V_+ = 13.0V$ , $R_L = 300\Omega$ , $C_L = 35pF$ , $V_{NO}$ or $V_{NC} = 10V$ , $V_{IN} = 0$ to 4, (See Figure 3)	Full	3	9	-	ns
Charge Injection, Q	$C_L = 1.0nF$ , $V_G = 0V$ , $R_G = 0\Omega$ , (See Figure 2)	25	-	1.2	3	pC
OFF Isolation	$R_L = 50\Omega$ , $C_L = 5pF$ , $f = 1MHz$ , (See Figure 4)	25	-	75	-	dB
Crosstalk (Channel-to-Channel)	$R_L = 50\Omega$ , $C_L = 5pF$ , $f = 1MHz$ , (See Figure 6)	25	-	-85	-	dB
NO or NC OFF Capacitance, $C_{OFF}$	$f = 1MHz$ , $V_{NO}$ or $V_{NC} = V_{COM} = 0V$ , (See Figure 7)	25	-	4	-	pF
COM OFF Capacitance, $C_{COM(OFF)}$	$f = 1MHz$ , $V_{NO}$ or $V_{NC} = V_{COM} = 0V$ , (See Figure 7)	25	-	6	-	pF
COM ON Capacitance, $C_{COM(ON)}$	$f = 1MHz$ , $V_{NO}$ or $V_{NC} = V_{COM} = 0V$ , (See Figure 7)	25	-	12	-	pF
<b>POWER SUPPLY CHARACTERISTICS</b>						
Positive Supply Current, $I_+$	$V_+ = 13.0V$ , $V_{IN} = 0V$ or $V_+$ , all channels on or off	Full	-1	0.0001	1	$\mu A$

Test Circuits and Waveforms

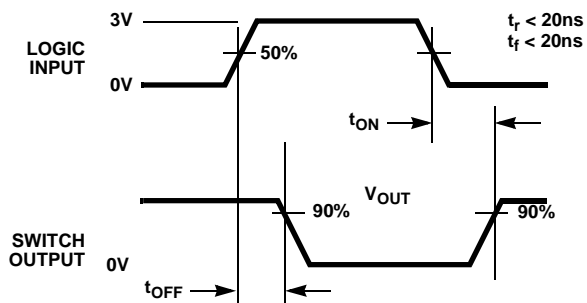

Logic input waveform is inverted for switches that have the opposite logic sense.

FIGURE 1A. MEASUREMENT POINTS

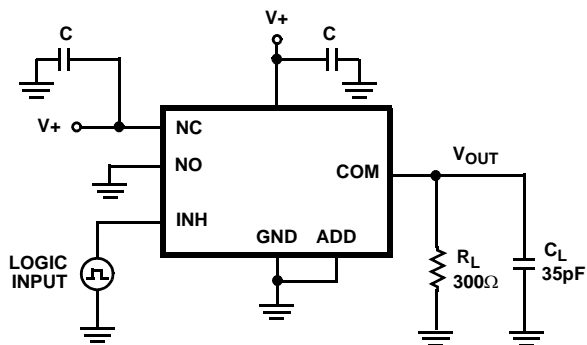

Repeat test for other switches.  $C_L$  includes fixture and stray capacitance.

$$V_{OUT} = V_{(NO \text{ or } NC)} \frac{R_L}{R_L + R_{(ON)}}$$

FIGURE 1B. TEST CIRCUIT

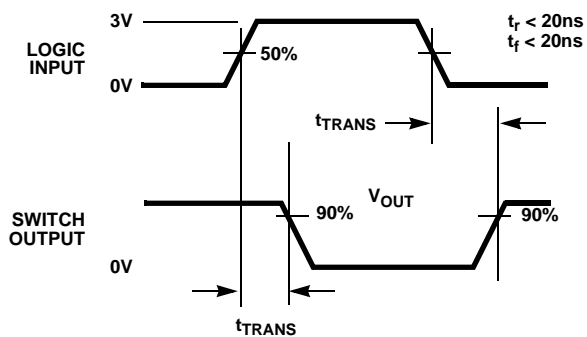

Logic input waveform is inverted for switches that have the opposite logic sense.

FIGURE 1C. ADDRESS MEASUREMENT POINTS

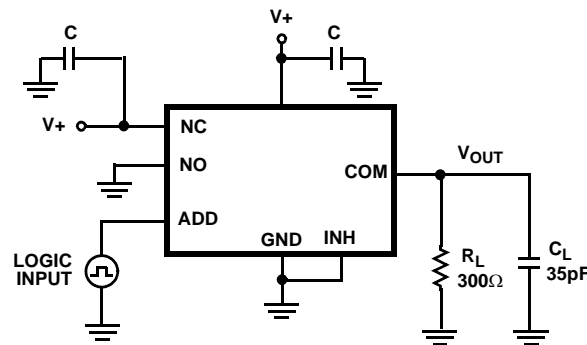

Repeat test for other switches.  $C_L$  includes fixture and stray capacitance.

$$V_{OUT} = V_{(NO \text{ or } NC)} \frac{R_L}{R_L + R_{(ON)}}$$

FIGURE 1D. ADDRESS TEST CIRCUIT

FIGURE 1. SWITCHING TIMES

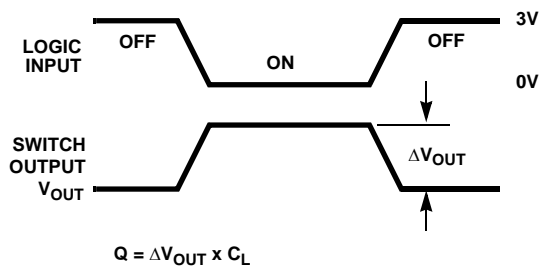

FIGURE 2A. MEASUREMENT POINTS

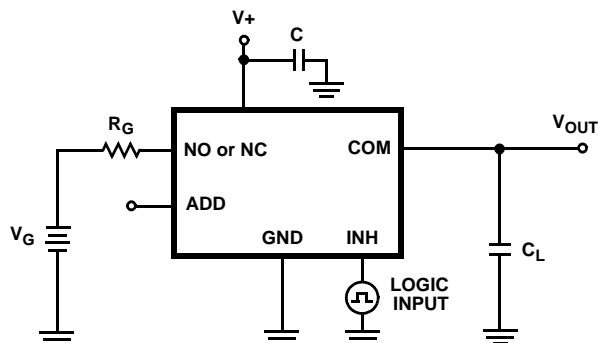

FIGURE 2B. TEST CIRCUIT

FIGURE 2. CHARGE INJECTION

Test Circuits and Waveforms (Continued)

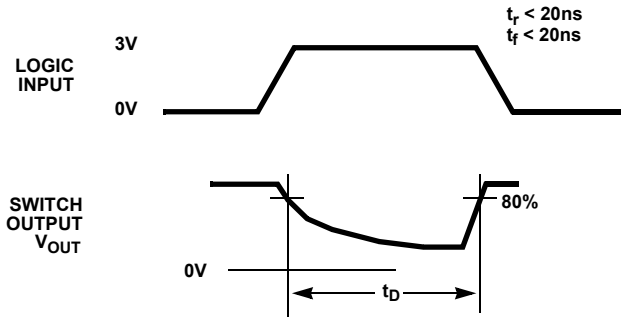
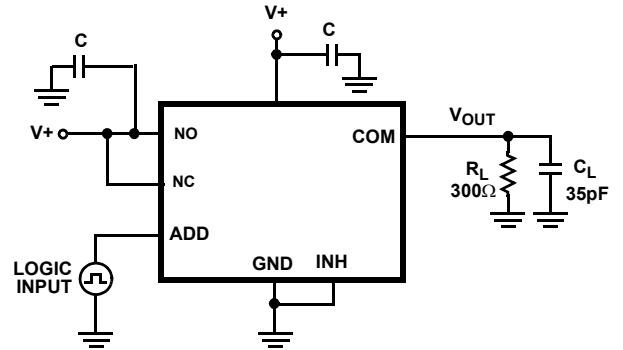

FIGURE 3A. MEASUREMENT POINTS



Repeat test for other switches.  $C_L$  includes fixture and stray capacitance.

FIGURE 3B. TEST CIRCUIT

FIGURE 3. BREAK-BEFORE-MAKE TIME

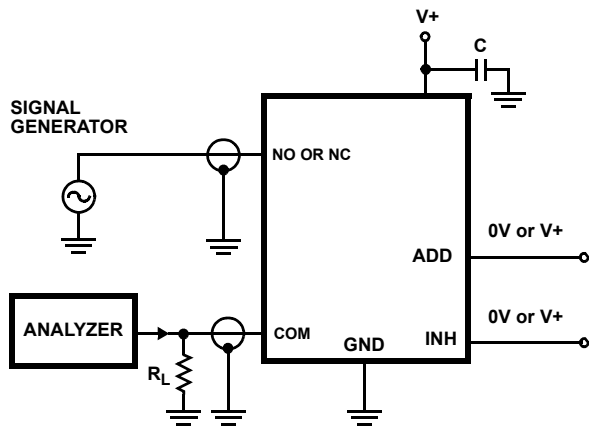

FIGURE 4. OFF ISOLATION TEST CIRCUIT

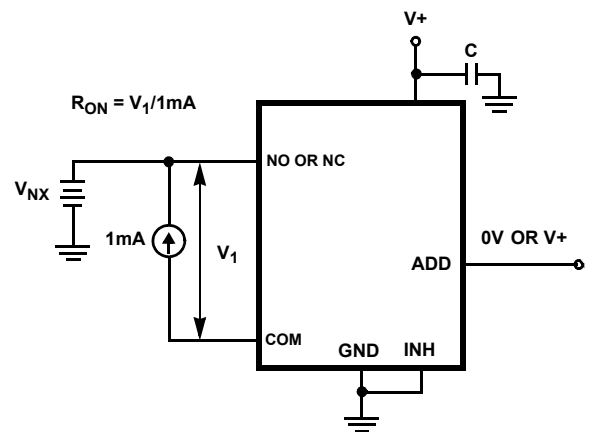

FIGURE 5.  $R_{ON}$  TEST CIRCUIT

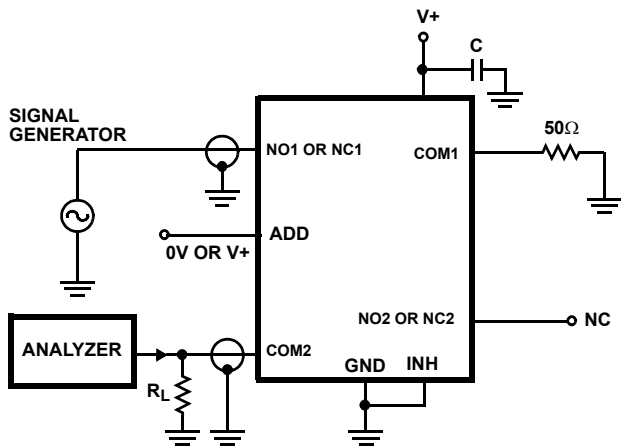

FIGURE 6. CROSSTALK TEST CIRCUIT

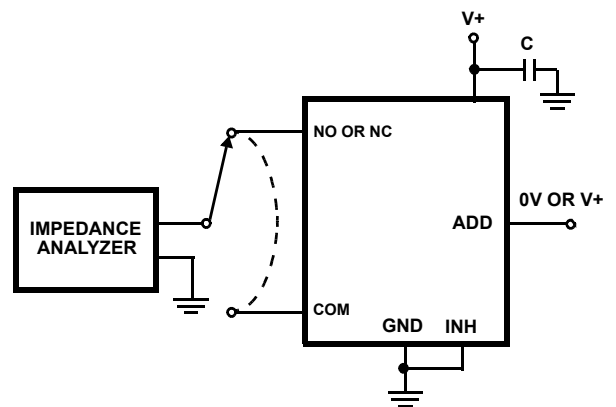

FIGURE 7. CAPACITANCE TEST CIRCUIT



# ISL43410

## Detailed Description

The ISL43410 operates from a single 2V to 12V supply with low on-resistance ( $115\Omega$ ) and high speed operation ( $t_{ON} = 60\text{ns}$ ,  $t_{OFF} = 30\text{ns}$ ). The ISL43410 is especially well suited to portable battery powered equipment thanks to the low operating supply voltage (2.0V), low power consumption ( $3\mu\text{W}$ ), low leakage currents (5nA max), and the tiny MSOP and QFN packaging. High frequency applications also benefit from the wide bandwidth, and the very high off isolation ( $75\text{dB}$ ) and crosstalk rejection ( $-85\text{dB}$ ).

## Supply Sequencing And Overvoltage Protection

With any CMOS device, proper power supply sequencing is required to protect the device from excessive input currents which might permanently damage the IC. All I/O pins contain ESD protection diodes from the pin to V+ and GND (see Figure 8). To prevent forward biasing these diodes, V+ must be applied before any input signals, and input signal voltages must remain between V+ and GND. If these conditions cannot be guaranteed, then one of the following two protection methods should be employed.

Logic inputs can easily be protected by adding a  $1\text{k}\Omega$  resistor in series with the input (see Figure 8). The resistor limits the input current below the threshold that produces permanent damage, and the sub-microamp input current produces an insignificant voltage drop during normal operation.

This method is not applicable for the signal path inputs. Adding a series resistor to the switch input defeats the purpose of using a low  $R_{ON}$  switch, so two small signal diodes can be added in series with the supply pins to provide overvoltage protection for all pins (see Figure 8). These additional diodes limit the analog signal from 1V below V+ to 1V above GND. The low leakage current performance is unaffected by this approach, but the switch resistance may increase, especially at low supply voltages.

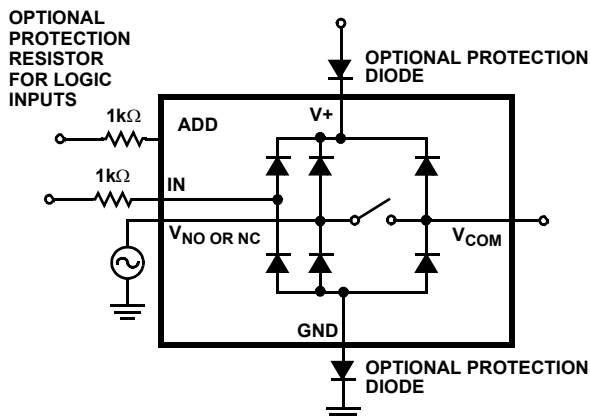

FIGURE 8. OVERVOLTAGE PROTECTION

## Power-Supply Considerations

The ISL43410 construction is typical of most CMOS analog switches, except that they have only two supply pins: V+ and GND. V+ and GND drive the internal CMOS switches and set their analog voltage limits. Unlike switches with a 13V maximum supply voltage, the ISL43410's 15V maximum supply voltage provides plenty of room for the 10% tolerance of 12V supplies, as well as room for overshoot and noise spikes.

The minimum recommended supply voltage is 2.0V. It is important to note that the input signal range, switching times, and on-resistance degrade at lower supply voltages. Refer to the electrical specification tables and *Typical Performance* curves for details.

V+ and GND also power the internal logic and level shifters. The level shifters convert the input logic levels to switched V+ and GND signals to drive the analog switch gate terminals.

This device cannot be operated with bipolar supplies, because the input switching point becomes negative in this configuration.

## Logic-Level Thresholds

The ISL43410 is TTL compatible (0.8V and 2.4V) over a supply range of 3V to 11V (see Figure 11). At 12V the  $V_{IH}$  level is about 2.5V. This is still below the TTL guaranteed high output minimum level of 2.8V, but noise margin is reduced. For best results with a 12V supply, use a logic family that provides a  $V_{OH}$  greater than 3V.

The digital input stages draw supply current whenever the digital input voltage is not at one of the supply rails (see Figure 12). Driving the digital input signals from GND to V+ with a fast transition time minimizes power dissipation. The ISL43410 has been designed to minimize the supply current whenever the digital input voltage is not driven to the supply rails (0V to V+). For example driving the device with 3V logic (0V to 3V) while operating with a 5V supply the device draws only  $10\mu\text{A}$  of current (see Figure 12 for  $V_{IN} = 3\text{V}$ ). Similar devices of competitors can draw 8 times this amount of current.

## High-Frequency Performance

In  $50\Omega$  systems, signal response is reasonably flat even past 100MHz (see Figure 17). Figure 17 also illustrates that the frequency response is very consistent over a wide V+ range, and for varying analog signal levels.

An OFF switch acts like a capacitor and passes higher frequencies with less attenuation, resulting in signal feed through from a switch's input to its output. Off Isolation is the resistance to this feed through, while Crosstalk indicates the amount of feed through from one switch to another. Figure 18 details the high Off Isolation and Crosstalk rejection provided by this family. At 10MHz, Off Isolation is about 55dB in  $50\Omega$  systems, decreasing approximately 20dB



## ISL43410

per decade as frequency increases. Higher load impedances decrease Off Isolation and Crosstalk rejection due to the voltage divider action of the switch OFF impedance and the load impedance.

### Leakage Considerations

Reverse ESD protection diodes are internally connected between each analog-signal pin and both V+ and GND. One of these diodes conducts if any analog signal exceeds V+ or GND.

Virtually all the analog leakage current comes from the ESD diodes to V+ or GND. Although the ESD diodes on a given

signal pin are identical and therefore fairly well balanced, they are reverse biased differently. Each is biased by either V+ or GND and the analog signal. This means their leakages will vary as the signal varies. The difference in the two diode leakages to the V+ and GND pins constitutes the analog-signal-path leakage current. All analog leakage current flows between each pin and one of the supply terminals, not to the other switch terminal. This is why both sides of a given switch can show leakage currents of the same or opposite polarity. There is no connection between the analog signal paths and V+ or GND.

### Typical Performance Curves $T_A = 25^\circ\text{C}$ , Unless Otherwise Specified

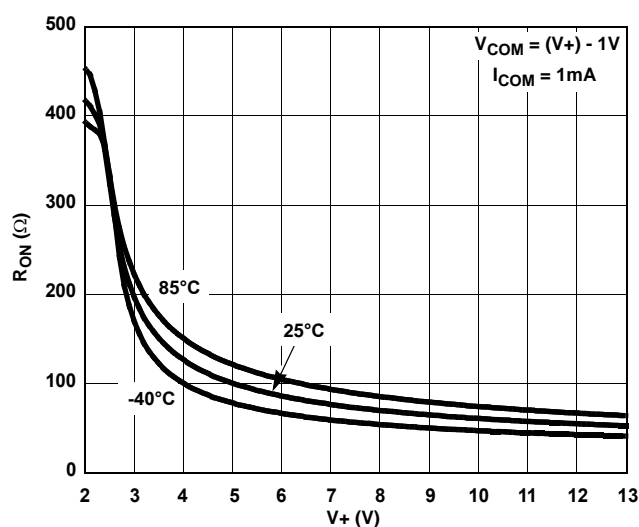

FIGURE 9. ON RESISTANCE vs SUPPLY VOLTAGE

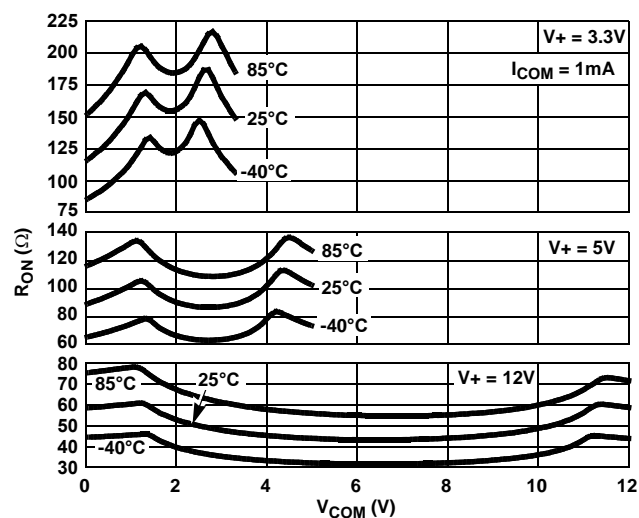

FIGURE 10. ON RESISTANCE vs SWITCH VOLTAGE

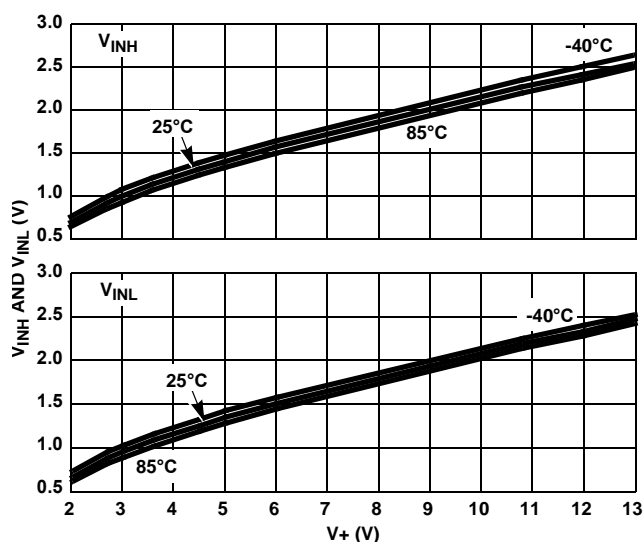

FIGURE 11. DIGITAL SWITCHING POINT vs SUPPLY VOLTAGE

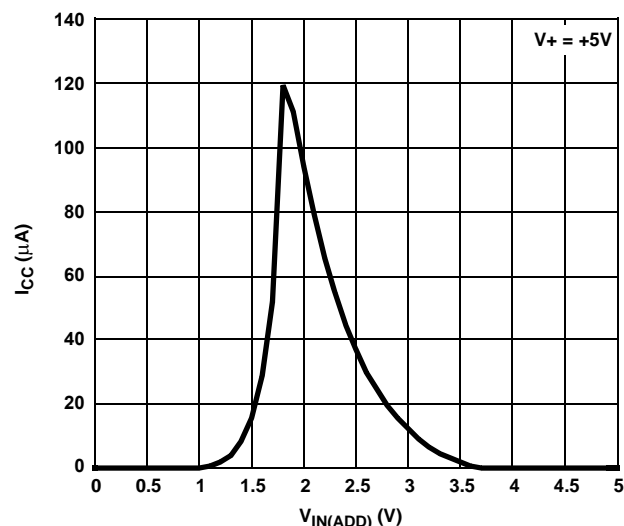

FIGURE 12. SUPPLY CURRENT vs DIGITAL ADDRESS INPUT VOLTAGE

# ISL43410

## Typical Performance Curves $T_A = 25^\circ\text{C}$ , Unless Otherwise Specified (Continued)

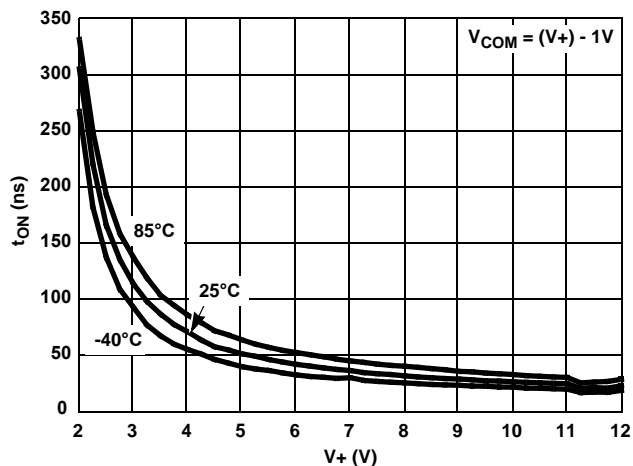

FIGURE 13. TURN - ON TIME vs SUPPLY VOLTAGE

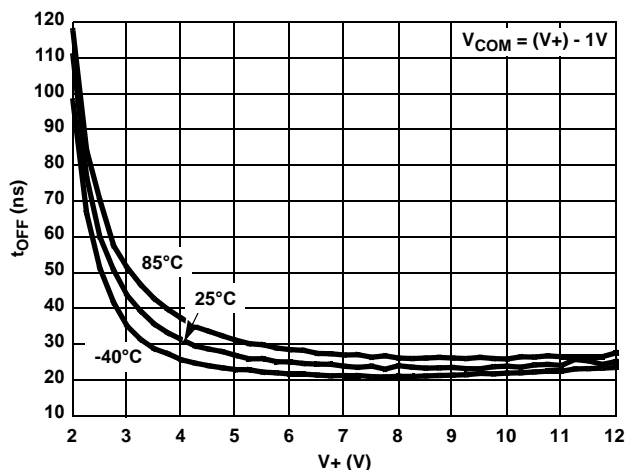

FIGURE 14. TURN - OFF TIME vs SUPPLY VOLTAGE

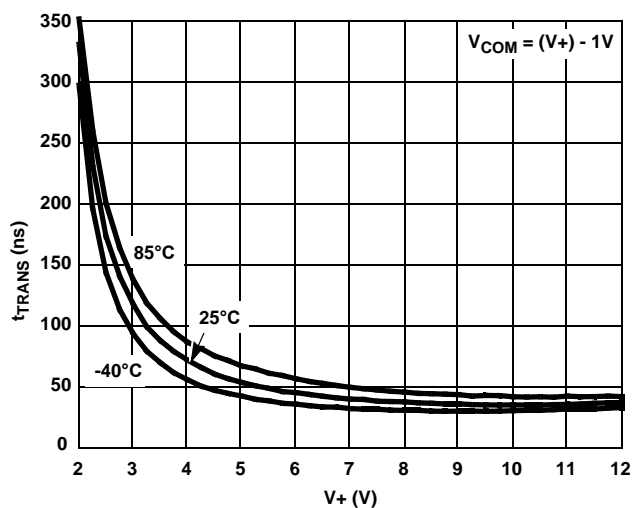

FIGURE 15. ADDRESS TRANS TIME vs SUPPLY VOLTAGE

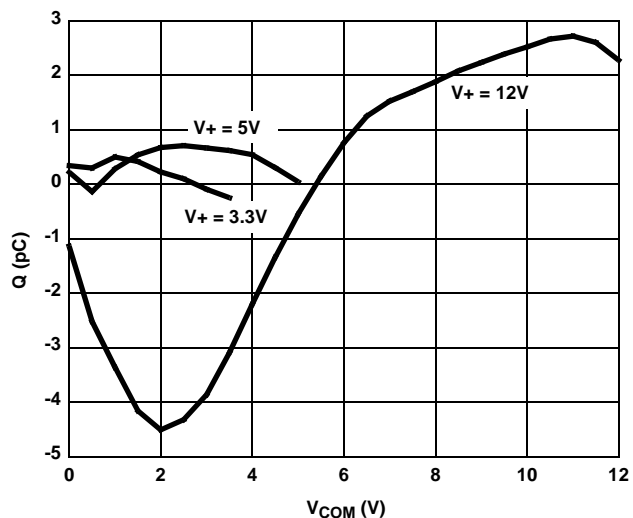

FIGURE 16. CHARGE INJECTION vs SWITCH VOLTAGE

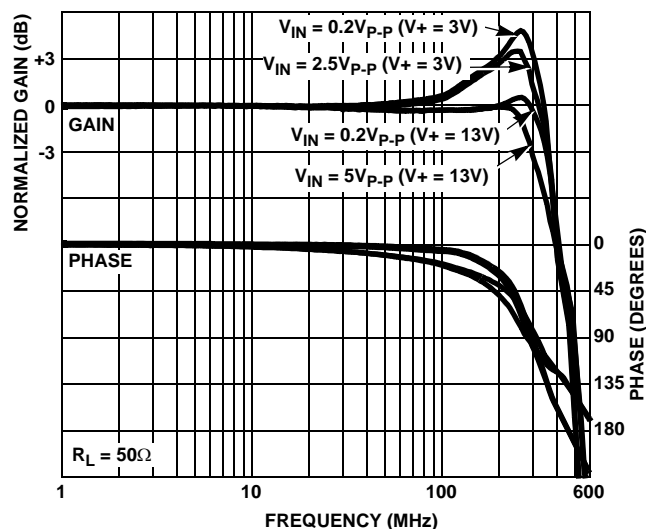

FIGURE 17. FREQUENCY RESPONSE

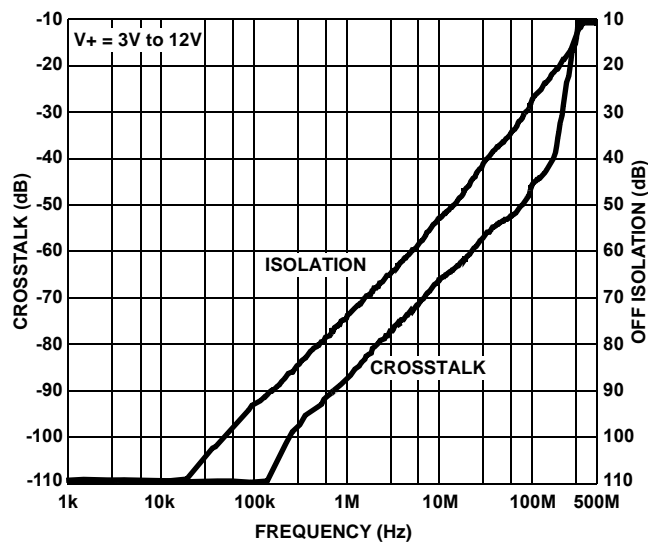

FIGURE 18. CROSSTALK AND OFF ISOLATION

## **ISL43410**

---

### ***Die Characteristics***

**SUBSTRATE POTENTIAL (POWERED UP):**

GND

**TRANSISTOR COUNT:**

193

**PROCESS:**

Si Gate CMOS

# ISL43410

## Mini Small Outline Plastic Packages (MSOP)

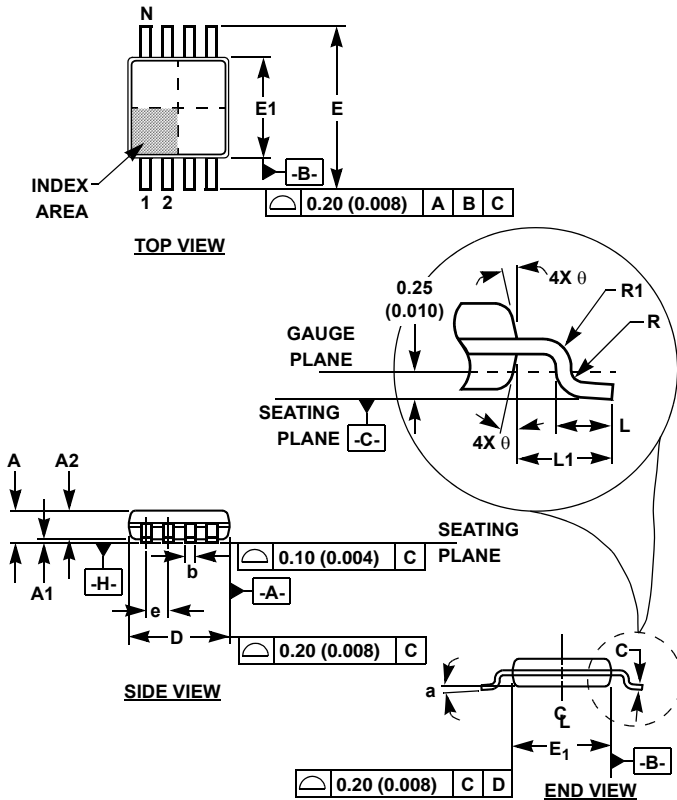

### M10.118 (JEDEC MO-187BA) 10 LEAD MINI SMALL OUTLINE PLASTIC PACKAGE

SYMBOL	INCHES		MILLIMETERS		NOTES
	MIN	MAX	MIN	MAX	
A	0.037	0.043	0.94	1.10	-
A1	0.002	0.006	0.05	0.15	-
A2	0.030	0.037	0.75	0.95	-
b	0.007	0.011	0.18	0.27	9
c	0.004	0.008	0.09	0.20	-
D	0.116	0.120	2.95	3.05	3
E1	0.116	0.120	2.95	3.05	4
e	0.020 BSC		0.50 BSC		-
E	0.187	0.199	4.75	5.05	-
L	0.016	0.028	0.40	0.70	6
L1	0.037 REF		0.95 REF		-
N	10		10		7
R	0.003	-	0.07	-	-
R1	0.003	-	0.07	-	-
$\theta$	5°	15°	5°	15°	-
$\alpha$	0°	6°	0°	6°	-

Rev. 0 12/02

#### NOTES:

1. These package dimensions are within allowable dimensions of JEDEC MO-187BA.
2. Dimensioning and tolerancing per ANSI Y14.5M-1994.
3. Dimension "D" does not include mold flash, protrusions or gate burrs and are measured at Datum Plane. Mold flash, protrusion and gate burrs shall not exceed 0.15mm (0.006 inch) per side.
4. Dimension "E1" does not include interlead flash or protrusions and are measured at Datum Plane.  $-H-$  Interlead flash and protrusions shall not exceed 0.15mm (0.006 inch) per side.
5. Formed leads shall be planar with respect to one another within 0.10mm (.004) at seating Plane.
6. "L" is the length of terminal for soldering to a substrate.
7. "N" is the number of terminal positions.
8. Terminal numbers are shown for reference only.
9. Dimension "b" does not include dambar protrusion. Allowable dambar protrusion shall be 0.08mm (0.003 inch) total in excess of "b" dimension at maximum material condition. Minimum space between protrusion and adjacent lead is 0.07mm (0.0027 inch).
10. Datums  $-A-$  and  $-B-$  to be determined at Datum plane  $-H-$ .
11. Controlling dimension: MILLIMETER. Converted inch dimensions are for reference only

# ISL43410

## Quad Flat No-Lead Plastic Package (QFN) Micro Lead Frame Plastic Package (MLFP)

## L16.3x3 16 LEAD QUAD FLAT NO-LEAD PLASTIC PACKAGE

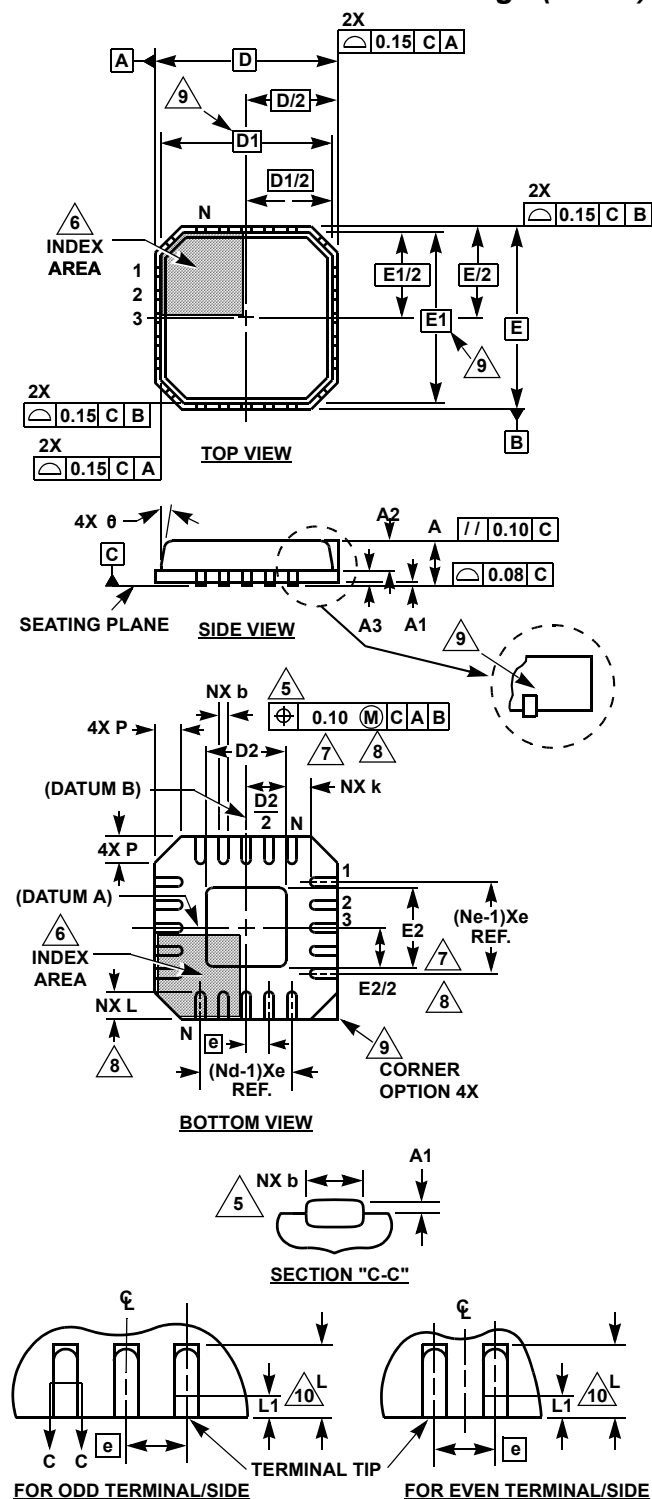

SYMBOL	MILLIMETERS			NOTES
	MIN	NOMINAL	MAX	
A	0.80	0.90	1.00	-
A1	-	-	0.05	-
A2	-	-	1.00	9
A3	0.20 REF			9
b	0.18	0.23	0.30	5, 8
D	3.00 BSC			-
D1	2.75 BSC			9
D2	1.35	1.50	1.65	7, 8, 10
E	3.00 BSC			-
E1	2.75 BSC			9
E2	1.35	1.50	1.65	7, 8, 10
e	0.50 BSC			-
k	0.20	-	-	-
L	0.30	0.40	0.50	8
N	16			2
Nd	4			3
Ne	4			3
P	-	-	0.60	9
θ	-	-	12	9

Rev. 1 6/04

### NOTES:

1. Dimensioning and tolerancing conform to ASME Y14.5-1994.
2. N is the number of terminals.
3. Nd and Ne refer to the number of terminals on each D and E.
4. All dimensions are in millimeters. Angles are in degrees.
5. Dimension b applies to the metallized terminal and is measured between 0.15mm and 0.30mm from the terminal tip.
6. The configuration of the pin #1 identifier is optional, but must be located within the zone indicated. The pin #1 identifier may be either a mold or mark feature.
7. Dimensions D2 and E2 are for the exposed pads which provide improved electrical and thermal performance.
8. Nominal dimensions are provided to assist with PCB Land Pattern Design efforts, see Intersil Technical Brief TB389.
9. Features and dimensions A2, A3, D1, E1, P & θ are present when Anvil singulation method is used and not present for saw singulation.
10. Compliant to JEDEC MO-220VEED-2 Issue C, except for the E2 and D2 MAX dimension.

All Intersil U.S. products are manufactured, assembled and tested utilizing ISO9000 quality systems.  
Intersil Corporation's quality certifications can be viewed at [www.intersil.com/design/quality](http://www.intersil.com/design/quality)

Intersil products are sold by description only. Intersil Corporation reserves the right to make changes in circuit design, software and/or specifications at any time without notice. Accordingly, the reader is cautioned to verify that data sheets are current before placing orders. Information furnished by Intersil is believed to be accurate and reliable. However, no responsibility is assumed by Intersil or its subsidiaries for its use; nor for any infringements of patents or other rights of third parties which may result from its use. No license is granted by implication or otherwise under any patent or patent rights of Intersil or its subsidiaries.

For information regarding Intersil Corporation and its products, see [www.intersil.com](http://www.intersil.com)