

## High Performance Pin Driver

The EL7156 high performance pin driver with 3-state is suited to many ATE and level-shifting applications. The 3.5A peak drive capability makes this part an excellent choice when driving high capacitance loads.

The output pin OUT is connected to input pins  $V_H$  or  $V_L$  respectively, depending on the status of the IN pin. When the OE pin is active low, the output is placed in the 3-state mode. The isolation of the output FETs from the power supplies enables  $V_H$  and  $V_L$  to be set independently, enabling level-shifting to be implemented. Related to the EL7155, the EL7156 adds a lower supply pin  $V_S-$  and makes  $V_L$  an isolated and independent input. This feature adds applications flexibility and improves switching response due to the increased enhancement of the output FETs.

This pin driver has improved performance over existing pin drivers. It is specifically designed to operate at voltages down to 0V across the switch elements while maintaining good speed and on-resistance characteristics.

Available in the 8 Ld SO and 8 Ld PDIP packages, the EL7156 is specified for operation over the full  $-40^{\circ}\text{C}$  to  $+85^{\circ}\text{C}$  temperature range.

## Pinout

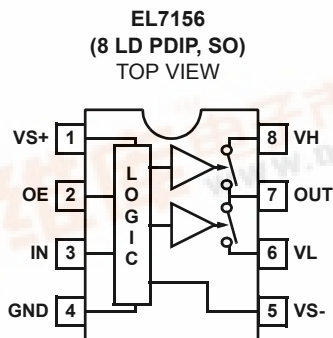

## Features

- Clocking speeds up to 40MHz
- 15ns tr/ff at 2000pF  $C_{LOAD}$
- 0.5ns rise and fall times mismatch
- 0.5ns  $T_{ON}-T_{OFF}$  prop delay mismatch
- 3.5pF typical input capacitance
- 3.5A peak drive
- Low on resistance of 3.5 $\Omega$
- High capacitive drive capability
- Operates from 4.5V to 16.5V
- Pb-free plus anneal available (RoHS compliant)

## Applications

- ATE/burn-in testers
- Level shifting
- IGBT drivers
- CCD drivers

## Ordering Information

PART NUMBER	PART MARKING	TAPE & REEL	PACKAGE	PKG. DWG. #
EL7156CN	EL7156CN	-	8 Ld PDIP	MDP0031
EL7156CNZ (Note)	EL7156CNZ	-	8 Ld PDIP* (Pb-free)	MDP0031
EL7156CS	7156CS	-	8 Ld SO	MDP0027
EL7156CS-T7	7156CS	7"	8 Ld SO	MDP0027
EL7156CS-T13	7156CS	13"	8 Ld SO	MDP0027
EL7156CSZ (Note)	7156CSZ	-	8 Ld SO (Pb-free)	MDP0027
EL7156CSZ-T7 (Note)	7156CSZ	7"	8 Ld SO (Pb-free)	MDP0027
EL7156CSZ-T13 (Note)	7156CSZ	13"	8 Ld SO (Pb-free)	MDP0027

NOTE: Intersil Pb-free plus anneal products employ special Pb-free material sets; molding compounds/die attach materials and 100% matte tin plate termination finish, which are RoHS compliant and compatible with both SnPb and Pb-free soldering operations. Intersil Pb-free products are MSL classified at Pb-free peak reflow temperatures that meet or exceed the Pb-free requirements of IPC/JEDEC J STD-020.

\*Pb-free PDIPs can be used for through hole wave solder processing only. They are not intended for use in Reflow solder processing applications.



# EL7156

## Absolute Maximum Ratings (T<sub>A</sub> = 25°C)

Supply Voltage (V<sub>S+</sub> to V<sub>S-</sub>) .....+18V  
 Input Voltage ..... V<sub>S-</sub> -0.3V, V<sub>S</sub> +0.3V  
 Continuous Output Current ..... 200mA  
 Storage Temperature Range .....-65°C to +150°C

Ambient Operating Temperature .....-40°C to +85°C  
 Operating Junction Temperature ..... 125°C  
 Power Dissipation ..... see curves

*CAUTION: Stresses above those listed in "Absolute Maximum Ratings" may cause permanent damage to the device. This is a stress only rating and operation of the device at these or any other conditions above those indicated in the operational sections of this specification is not implied.*

*IMPORTANT NOTE: All parameters having Min/Max specifications are guaranteed. Typical values are for information purposes only. Unless otherwise noted, all tests are at the specified temperature and are pulsed tests, therefore: T<sub>J</sub> = T<sub>C</sub> = T<sub>A</sub>*

## Electrical Specifications V<sub>S+</sub> = +15V, V<sub>H</sub> = +15V, V<sub>L</sub> = 0V, V<sub>S-</sub> = 0V, T<sub>A</sub> = 25°C, unless otherwise specified.

PARAMETER	DESCRIPTION	CONDITION	MIN	TYP	MAX	UNIT
<b>INPUT</b>						
V <sub>IH</sub>	Logic '1' Input Voltage		2.4			V
I <sub>IH</sub>	Logic '1' Input Current	V <sub>IH</sub> = V <sub>S+</sub>		0.1	10	μA
V <sub>IL</sub>	Logic '0' Input Voltage				0.8	V
I <sub>IL</sub>	Logic '0' Input Current	V <sub>IL</sub> = 0V		0.1	10	μA
C <sub>IN</sub>	Input Capacitance			3.5		pF
R <sub>IN</sub>	Input Resistance			50		MΩ
<b>OUTPUT</b>						
R <sub>OVH</sub>	ON Resistance V <sub>H</sub> to OUT	I <sub>OUT</sub> = -200 mA		2.7	4.5	Ω
R <sub>OVL</sub>	ON Resistance V <sub>L</sub> to OUT	I <sub>OUT</sub> = +200 mA		3.5	5.5	Ω
I <sub>OUT</sub>	Output Leakage Current	OE = 0V, OUT = V <sub>H</sub> /V <sub>L</sub>		0.1	10	μA
I <sub>PK</sub>	Peak Output Current (linear resistive operation)	Source		3.5		A
		Sink		3.5		A
I <sub>DC</sub>	Continuous Output Current	Source/Sink	200			mA
<b>POWER SUPPLY</b>						
I <sub>S</sub>	Power Supply Current	Inputs = V <sub>S+</sub>		1.3	3	mA
I <sub>VH</sub>	Off Leakage at V <sub>H</sub> and V <sub>L</sub>	V <sub>H</sub> , V <sub>L</sub> = 0V		4	10	μA
<b>SWITCHING CHARACTERISTICS</b>						
t <sub>R</sub>	Rise Time	C <sub>L</sub> = 2000pF		14.5		ns
t <sub>F</sub>	Fall Time	C <sub>L</sub> = 2000pF		15		ns
t <sub>RFΔ</sub>	t <sub>R</sub> , t <sub>F</sub> Mismatch	C <sub>L</sub> = 2000pF		0.5		ns
t <sub>D-1</sub>	Turn-Off Delay Time	C <sub>L</sub> = 2000pF		9.5		ns
t <sub>D-2</sub>	Turn-On Delay Time	C <sub>L</sub> = 2000pF		10		ns
t <sub>DΔ</sub>	t <sub>D-1</sub> -t <sub>D-2</sub> Mismatch	C <sub>L</sub> = 2000pF		0.5		ns
t <sub>D-3</sub>	3-state Delay Enable			10		ns
t <sub>D-4</sub>	3-state Delay Disable			10		ns

## EL7156

### Electrical Specifications $V_{S+} = +5V, V_H = +5V, V_L = -5V, V_{S-} = -5V, T_A = 25^\circ C$ , unless otherwise specified

PARAMETER	DESCRIPTION	CONDITION	MIN	TYP	MAX	UNIT
<b>INPUT</b>						
$V_{IH}$	Logic '1' Input Voltage		2.0			V
$I_{IH}$	Logic '1' Input Current	$V_{IH} = V_{S+}$		0.1	10	$\mu A$
$V_{IL}$	Logic '0' Input Voltage				0.8	V
$I_{IL}$	Logic '0' Input Current	$V_{IL} = 0V$		0.1	10	$\mu A$
$C_{IN}$	Input Capacitance			3.5		pF
$R_{IN}$	Input Resistance			50		M $\Omega$
<b>OUTPUT</b>						
$R_{OVH}$	ON Resistance $V_H$ to OUT	$I_{OUT} = -200mA$		3.4	5	$\Omega$
$R_{OVL}$	ON Resistance $V_L$ to OUT	$I_{OUT} = +200mA$		4	6	$\Omega$
$I_{OUT}$	Output Leakage Current	$OE = 0V, OUT = V_H/V_L$		0.1	10	$\mu A$
$I_{PK}$	Peak Output Current (linear resistive operation)	Source		3.5		A
		Sink		3.5		A
$I_{DC}$	Continuous Output Current	Source/Sink	200			mA
<b>POWER SUPPLY</b>						
$I_S$	Power Supply Current	Inputs = $V_{S+}$		1	2.5	mA
$V_H$	Off Leakage at $V_H$ and $V_L$	$V_H, V_L = 0V$		4	10	$\mu A$
<b>SWITCHING CHARACTERISTICS</b>						
$t_R$	Rise Time	$C_L = 2000pF$		17		ns
$t_F$	Fall Time	$C_L = 2000pF$		17		ns
$t_{RFA}$	$t_R, t_F$ Mismatch	$C_L = 2000pF$		0		ns
$t_{D-1}$	Turn-Off Delay Time	$C_L = 2000pF$		11.5		ns
$t_{D-2}$	Turn-On Delay Time	$C_L = 2000pF$		12		ns
$t_{D\Delta}$	$t_{D-1} - t_{D-2}$ Mismatch	$C_L = 2000pF$		0.5		ns
$t_{D-3}$	3-state Delay Enable			10		ns
$t_{D-4}$	3-state Delay Disable			10		ns

Typical Performance Curves

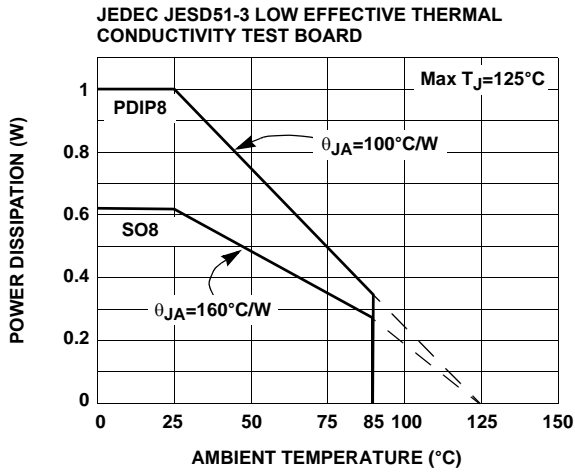

FIGURE 1. PACKAGE POWER DISSIPATION vs AMBIENT TEMPERATURE

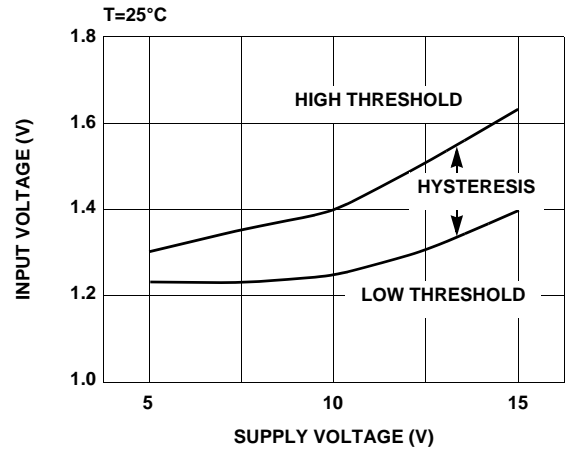

FIGURE 2. INPUT THRESHOLD vs SUPPLY VOLTAGE

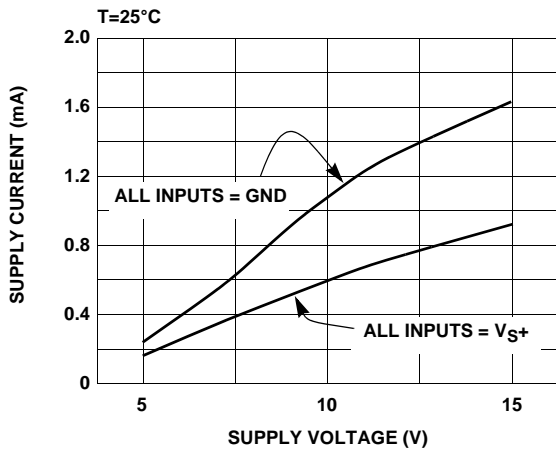

FIGURE 3. QUIESCENT SUPPLY CURRENT vs SUPPLY VOLTAGE

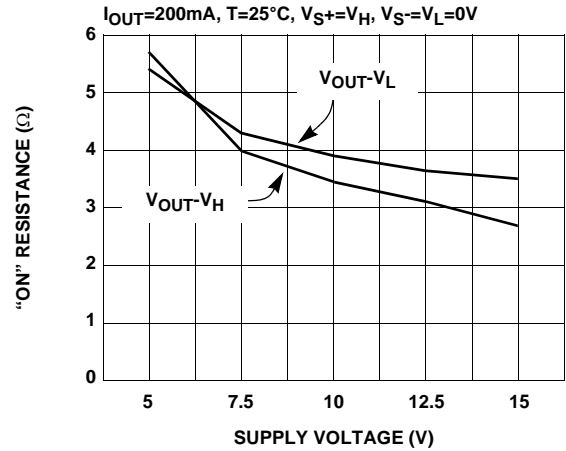

FIGURE 4. "ON" RESISTANCE vs SUPPLY VOLTAGE

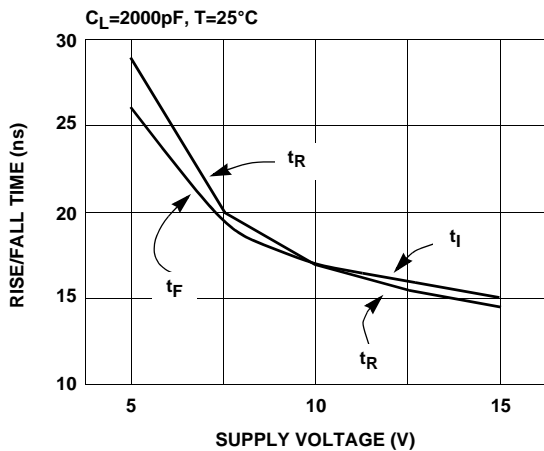

FIGURE 5. RISE/FALL TIME vs SUPPLY VOLTAGE

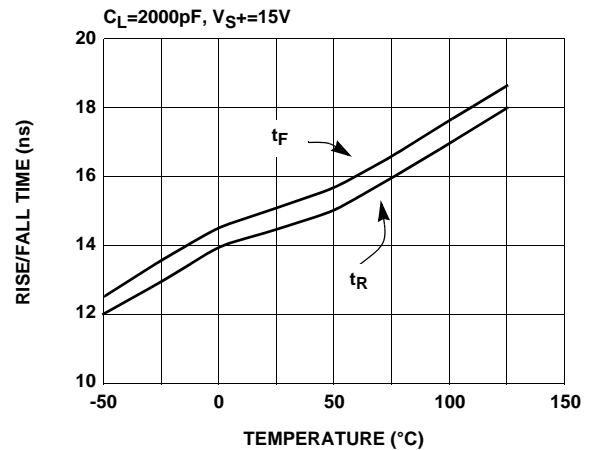

FIGURE 6. RISE/FALL TIME vs TEMPERATURE

Typical Performance Curves (Continued)

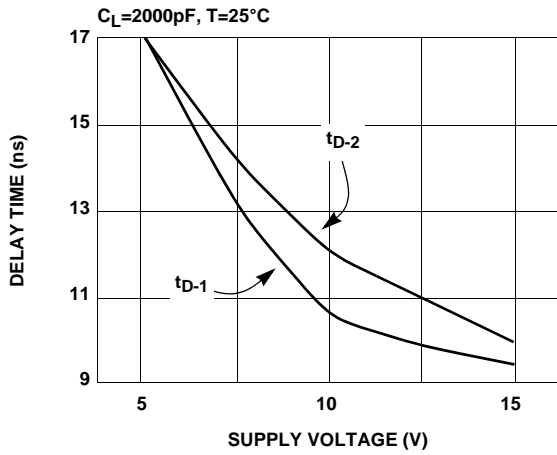

FIGURE 7. PROPAGATION DELAY vs SUPPLY VOLTAGE

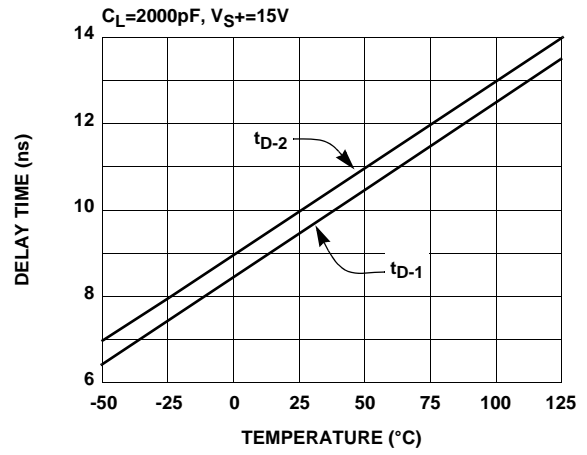

FIGURE 8. PROPAGATION DELAY vs TEMPERATURE

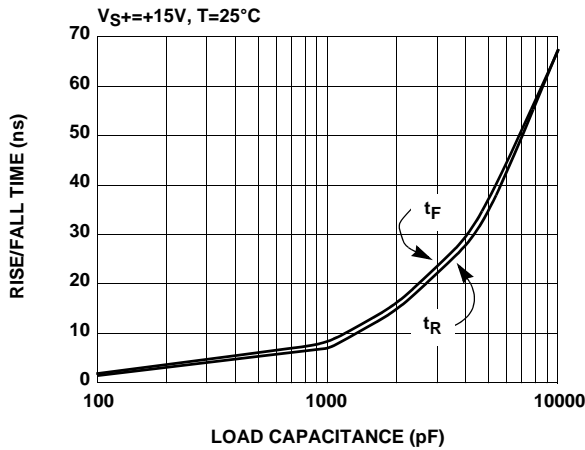

FIGURE 9. RISE/FALL TIME vs LOAD CAPACITANCE

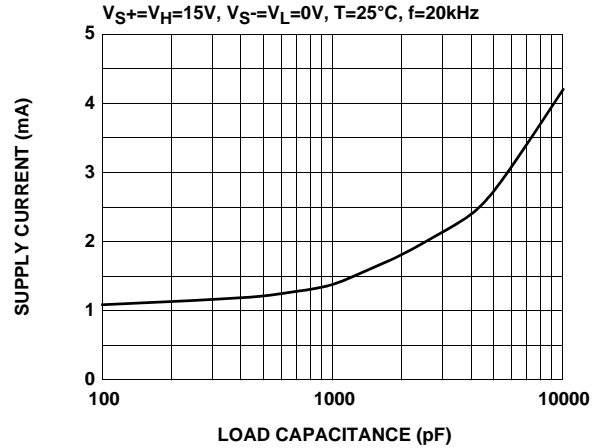

FIGURE 10. SUPPLY CURRENT vs LOAD CAPACITANCE

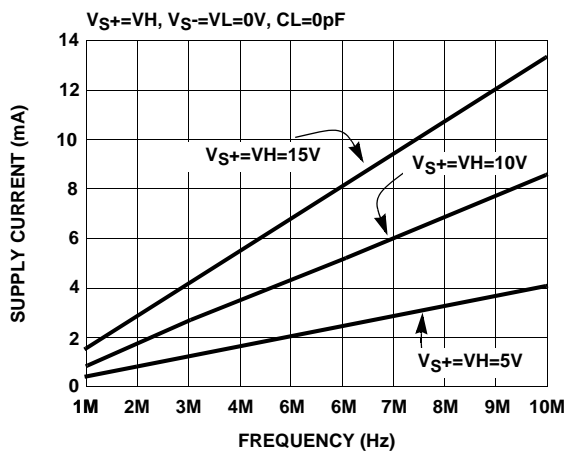

FIGURE 11. SUPPLY CURRENT vs FREQUENCY

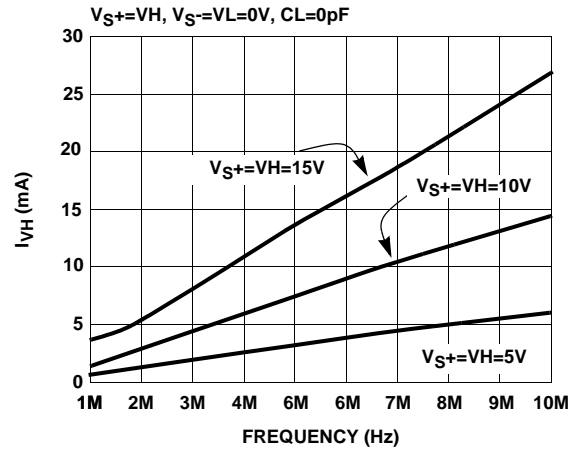

FIGURE 12. VH SUPPLY CURRENT vs FREQUENCY

# EL7156

## Truth Table

OE	IN	OUT
0	0	3-state
0	1	3-state
1	0	$V_H$
1	1	$V_L$

## Operating Voltage Range

PIN	MIN	MAX
$GND - V_{S-}$	-5	0
$V_{S+} - V_{S-}$	5	16.5
$V_H - V_L$	0	16.5
$V_{S+} - V_H$	0	16.5
$V_{S+} - GND$	5	16.5
$V_L - V_{S-}$	0	16.5
3-state Output	$V_L$	$V_H$

## Timing Diagram

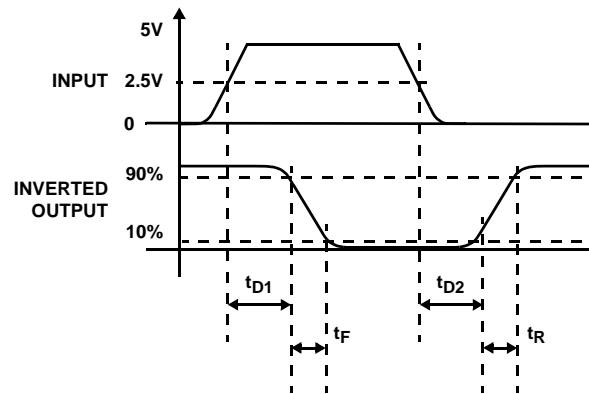

## Standard Test Configuration

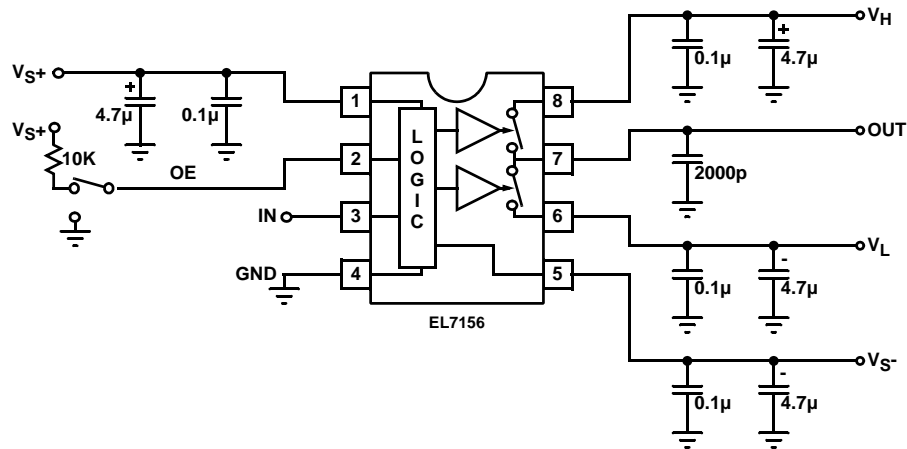

# EL7156

## Pin Descriptions

PIN	NAME	FUNCTION	EQUIVALENT CIRCUIT
1	VS+	Positive Supply Voltage	
2	OE	Output Enable	<p>CIRCUIT 1</p>
3	IN	Input	Reference Circuit 1
4	GND	Ground	
5	VS-	Negative Supply Voltage	
6	VL	Lower Output Voltage	
7	OUT	Output	<p>CIRCUIT 2</p>
8	VH	High Output Voltage	

## Block Diagram

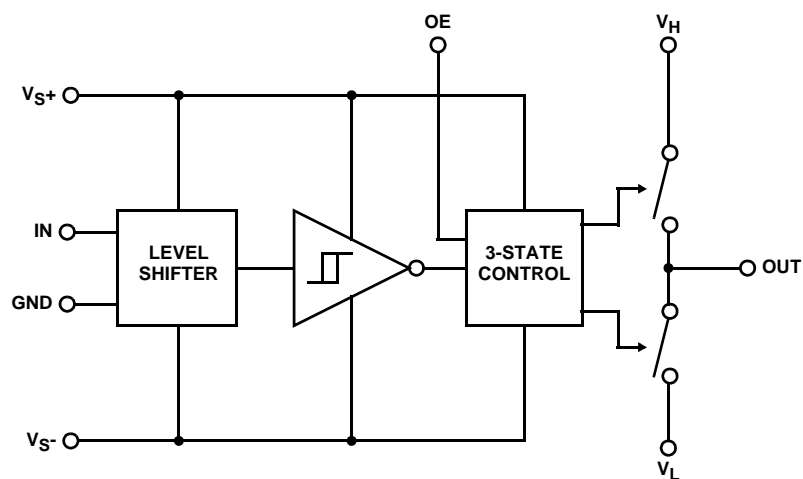

## EL7156

### Applications Information

#### Product Description

The EL7156 is a high performance 40MHz pin driver. It contains two analog switches connecting  $V_H$  and  $V_L$  to OUT. Depending on the value of the IN pin, one of the two switches will be closed and the other switch open. An output enable (OE) is also supplied which opens both switches simultaneously.

Due to the topology of the EL7156, both the  $V_H$  and  $V_L$  pins can be connected to any voltage between the  $V_{S+}$  and  $V_{S-}$  pins, but  $V_H$  must be greater than  $V_L$  in order to prevent turning on the body diode at the output stage.

The EL7156 is available in both the 8 Ld SO and the 8 Ld PDIP packages. The relevant package should be chosen depending on the calculated power dissipation.

#### 3-state Operation

When the OE pin is low, the output is 3-state (floating.) The output voltage is the parasitic capacitance's voltage. It can be any voltage between  $V_H$  and  $V_L$ , depending on the previous state. At 3-state, the output voltage can be pushed to any voltage between  $V_H$  and  $V_L$ . The output voltage can't be pushed higher than  $V_H$  or lower than  $V_L$  since the body diode at the output stage will turn on.

#### Supply Voltage Range and Input Compatibility

The EL7156 is designed for operation on supplies from 5V to 15V (4.5V to 16.5V maximum). The table on page 6 shows the specifications for the relationship between the  $V_{S+}$ ,  $V_{S-}$ ,  $V_H$ ,  $V_L$ , and GND pins.

All input pins are compatible with both 3V and 5V CMOS signals. With a positive supply ( $V_{S+}$ ) of 5V, the EL7156 is also compatible with TTL inputs.

#### Power Supply Bypassing

When using the EL7156, it is very important to use adequate power supply bypassing. The high switching currents developed by the EL7156 necessitate the use of a bypass capacitor between the supplies ( $V_{S+}$  &  $V_{S-}$ ) and GND pins. It is recommended that a 2.2 $\mu$ F tantalum capacitor be used in parallel with a 0.1 $\mu$ F low-inductance ceramic MLC capacitor. These should be placed as close to the supply pins as possible. It is also recommended that the  $V_H$  and  $V_L$  pins have some level of bypassing, especially if the EL7156 is driving highly capacitive loads.

#### Power Dissipation Calculation

When switching at high speeds, or driving heavy loads, the EL7156 drive capability is limited by the rise in die temperature brought about by internal power dissipation. For reliable operation die temperature must be kept below  $T_{JMAX}$  (125°C). It is necessary to calculate the power dissipation for a given application prior to selecting the package type.

Power dissipation may be calculated:

$$PD = (V_S \times I_S) + (C_{VS} \times V_S^2 \times f) + [(C_{INT} + C_L) \times V_{OUT}^2 \times f]$$

where:

$V_S$  is the total power supply to the EL7156 (from  $V_{S+}$  to GND)

$V_{OUT}$  is the swing on the output ( $V_H - V_L$ )

$C_{VS}$  is the integral capacitance due to  $V_{S+}$

$C_{INT}$  is the integral load capacitance due to  $V_H$

$I_S$  is the quiescent supply current (3mA max)

$f$  is frequency

TABLE 1. INTEGRAL CAPACITANCE

$V_{S+}=V_H(V)$	$C_{VS}(pF)$	$C_{INT}(pF)$
5	80	120
10	85	145
15	90	180

Having obtained the application's power dissipation, a maximum package thermal coefficient may be determined, to maintain the internal die temperature below  $T_{JMAX}$ :

$$\theta_{JA} = \frac{T_{JMAX} - T_{MAX}}{PD}$$

where:

$T_{JMAX}$  is the maximum junction temperature (125°C)

$T_{MAX}$  is the maximum operating temperature

PD is the power dissipation calculated above

$\theta_{JA}$  thermal resistance on junction to ambient

$\theta_{JA}$  is 160°C/W for the SO8 package and 100°C/W for the PDIP8 package when using a standard JEDEC JESD51-3 single-layer test board. If  $T_{JMAX}$  is greater than 125°C when calculated using the equation above, then one of the following actions must be taken:

Reduce  $\theta_{JA}$  the system by designing more heat-sinking into the PCB (as compared to the standard JEDEC JESD51-3)

Use the PDIP8 instead of the SO8 package

De-rate the application either by reducing the switching frequency, the capacitive load, or the maximum operating (ambient) temperature ( $T_{MAX}$ )



# EL7156

## SO Package Outline Drawing

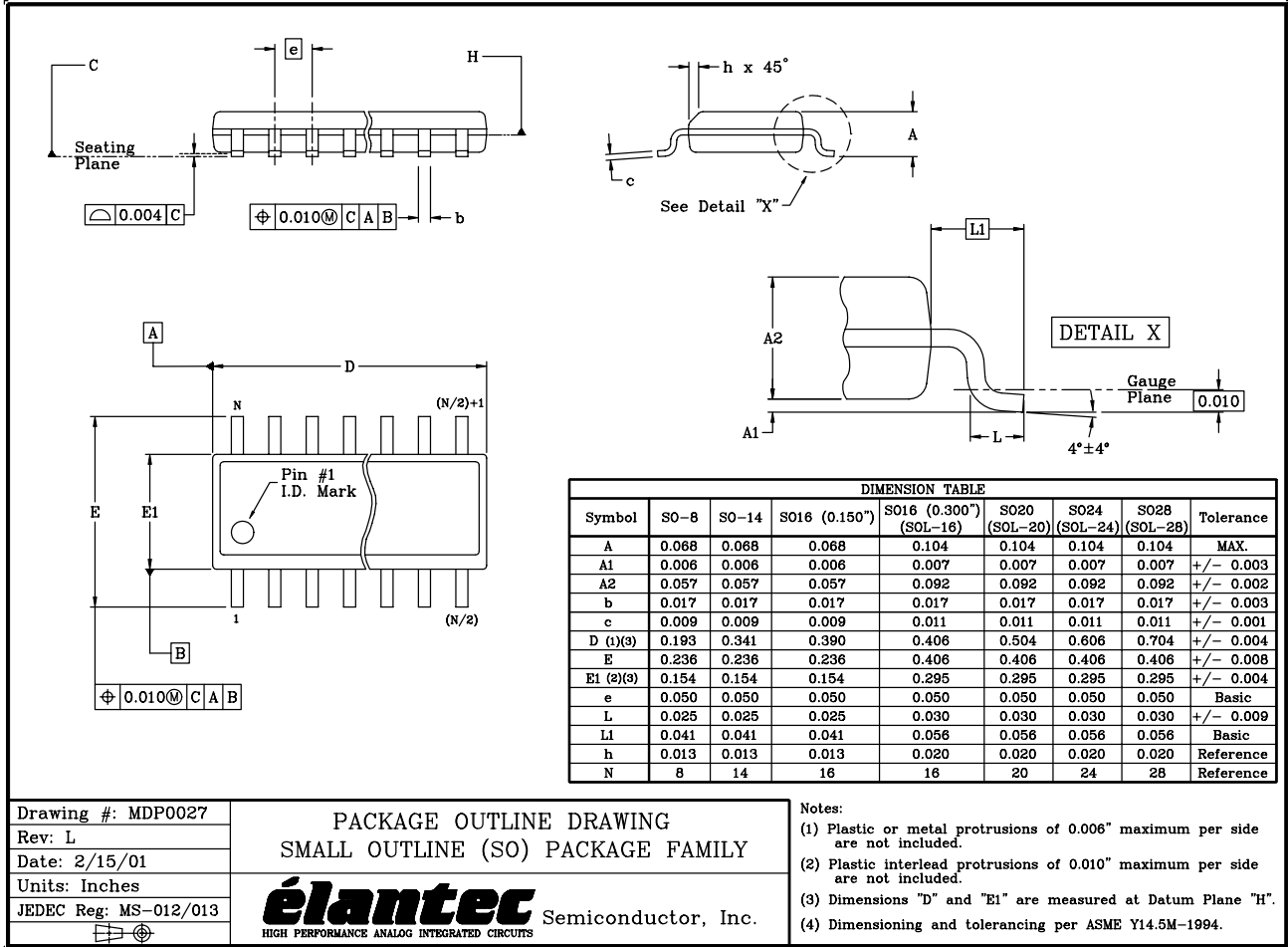

Drawing #: MDP0027  
 Rev: L  
 Date: 2/15/01  
 Units: Inches  
 JEDEC Reg: MS-012/013

PACKAGE OUTLINE DRAWING  
 SMALL OUTLINE (SO) PACKAGE FAMILY

**élantec** Semiconductor, Inc.  
 HIGH PERFORMANCE ANALOG INTEGRATED CIRCUITS

Notes:  
 (1) Plastic or metal protrusions of 0.006" maximum per side are not included.  
 (2) Plastic interlead protrusions of 0.010" maximum per side are not included.  
 (3) Dimensions "D" and "E1" are measured at Datum Plane "H".  
 (4) Dimensioning and tolerancing per ASME Y14.5M-1994.

# EL7156

## PDIP Package Outline Drawing

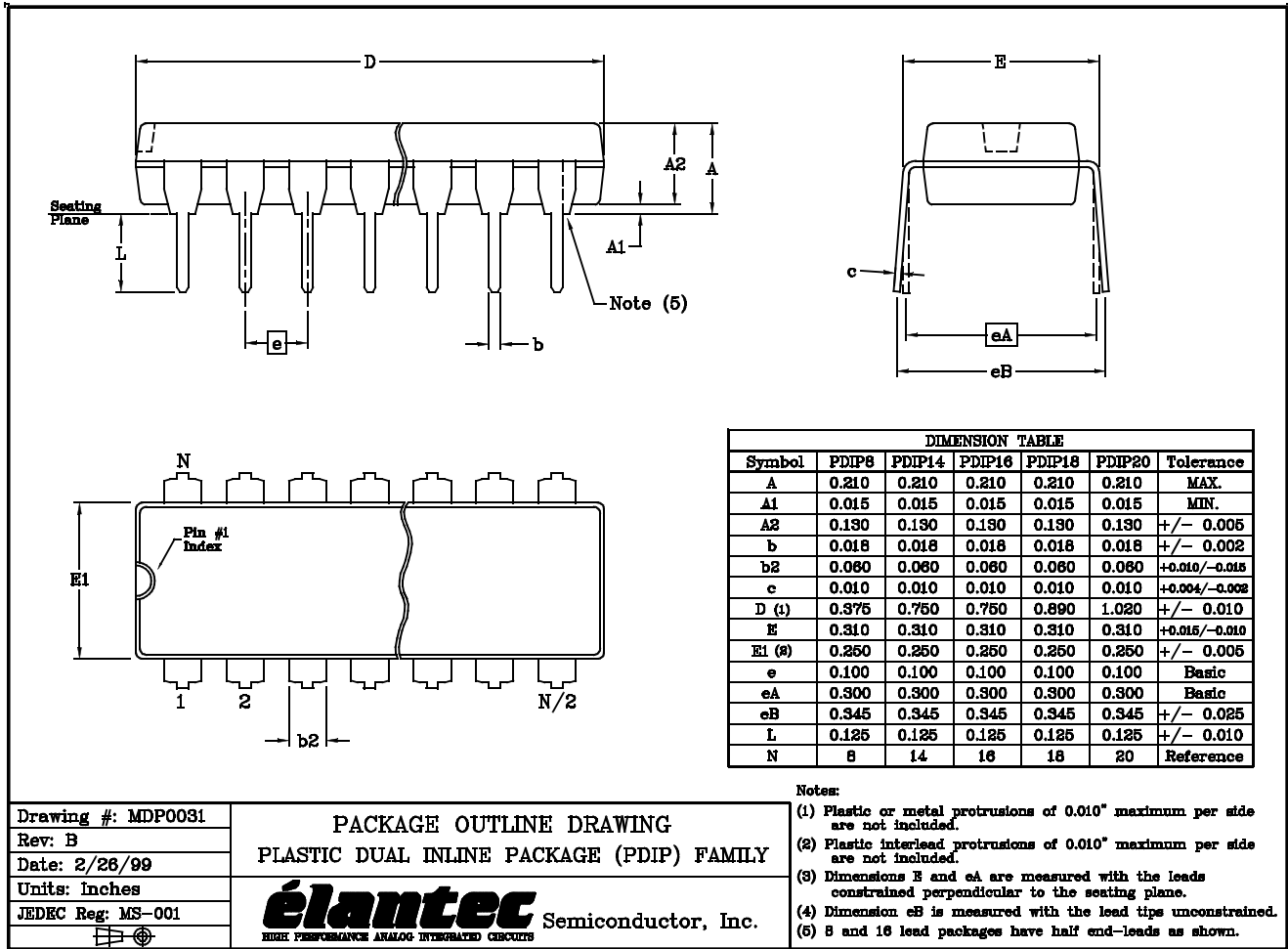

NOTE: The package drawing shown here may not be the latest version. To check the latest revision, please refer to the Intersil website at <<http://www.intersil.com/design/packages/index.asp>>

All Intersil U.S. products are manufactured, assembled and tested utilizing ISO9000 quality systems. Intersil Corporation's quality certifications can be viewed at [www.intersil.com/design/quality](http://www.intersil.com/design/quality)

Intersil products are sold by description only. Intersil Corporation reserves the right to make changes in circuit design, software and/or specifications at any time without notice. Accordingly, the reader is cautioned to verify that data sheets are current before placing orders. Information furnished by Intersil is believed to be accurate and reliable. However, no responsibility is assumed by Intersil or its subsidiaries for its use; nor for any infringements of patents or other rights of third parties which may result from its use. No license is granted by implication or otherwise under any patent or patent rights of Intersil or its subsidiaries.

For information regarding Intersil Corporation and its products, see [www.intersil.com](http://www.intersil.com)