

Monolithic, Quad SPST, CMOS Analog Switches

The DG441 and DG442 monolithic CMOS analog switches are drop-in replacements for the popular DG201A and DG202 series devices. They include four independent single pole single throw (SPST) analog switches, TTL and CMOS compatible digital inputs, and a voltage reference for logic thresholds.

These switches feature lower analog ON resistance (<85Ω) and faster switch time ($t_{ON} < 250\text{ns}$) compared to the DG201A and DG202. Charge injection has been reduced, simplifying sample and hold applications.

The improvements in the DG441 series are made possible by using a high voltage silicon-gate process. An epitaxial layer prevents the latch-up associated with older CMOS technologies. The 44V maximum voltage range permits controlling 40V_{P-P} signals. Power supplies may be single-ended from +5V to +34V, or split from ±5V to ±20V.

The four switches are bilateral, equally matched for AC or bidirectional signals. The ON resistance variation with analog signals is quite low over a ±5V analog input range. The switches in the DG441 and DG442 are identical, differing only in the polarity of the selection logic.

Ordering Information

PART NUMBER	TEMP. RANGE (°C)	PACKAGE	PKG. DWG. #
DG441DJ	-40 to 85	16 Ld PDIP	E16.3
DG441DJZ (See Note)	-40 to 85	16 Ld PDIP (Pb-free)	E16.3
DG441DY	-40 to 85	16 Ld SOIC	M16.15
DG441DY-T	16 Ld SOIC Tape and Reel		M16.15
DG441DYZ (See Note)	-40 to 85	16 Ld SOIC (Pb-free)	M16.15
DG441DYZ-T (See Note)	16 Ld SOIC Tape and Reel (Pb-free)		M16.15
DG442DJ	-40 to 85	16 Ld PDIP	E16.3
DG442DJZ (See Note)	-40 to 85	16 Ld PDIP (Pb-free)	E16.3
DG442DY	-40 to 85	16 Ld SOIC	M16.15
DG442DY-T	16 Ld SOIC Tape and Reel		M16.15
DG442DYZ-T (See Note)	16 Ld SOIC Tape and Reel (Pb-free)		M16.15

NOTE: Intersil Pb-free products employ special Pb-free material sets; molding compounds/die attach materials and 100% matte tin plate termination finish, which is compatible with both SnPb and Pb-free soldering operations. Intersil Pb-free products are MSL classified at Pb-free peak reflow temperatures that meet or exceed the Pb-free requirements of IPC/JEDEC J Std-020B.

Features

- ON Resistance (Max)..... 85Ω
- Low Power Consumption (P_D)..... <1.6mW
- Fast Switching Action
 - t_{ON} (Max)..... 250ns
 - t_{OFF} (Max, DG441)..... 120ns
- Low Charge Injection
- Upgrade from DG201A/DG202
- TTL, CMOS Compatible
- Single or Split Supply Operation
- Pb-free Available

Applications

- Audio Switching
- Battery Operated Systems
- Data Acquisition
- Hi-Rel Systems
- Sample and Hold Circuits
- Communication Systems
- Automatic Test Equipment

Pinout

DG441, DG442
 (PDIP, SOIC)
 TOP VIEW

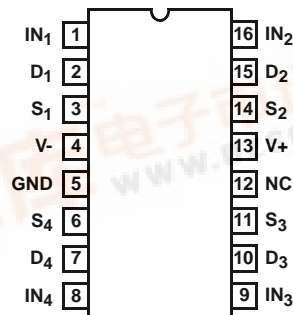

DG441, DG442

Functional Diagrams

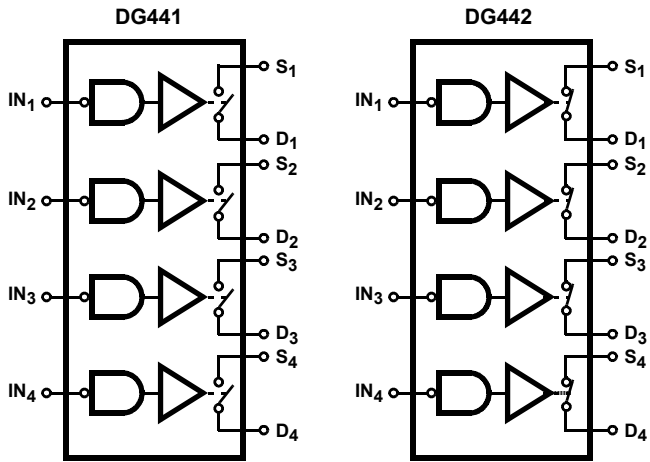

SWITCHES SHOWN FOR LOGIC "1" INPUT

TRUTH TABLE

LOGIC	V _{IN}	DG441	DG442
0	≤0.8V	ON	OFF
1	≥2.4V	OFF	ON

DG441, DG442

Schematic Diagram (One Channel)

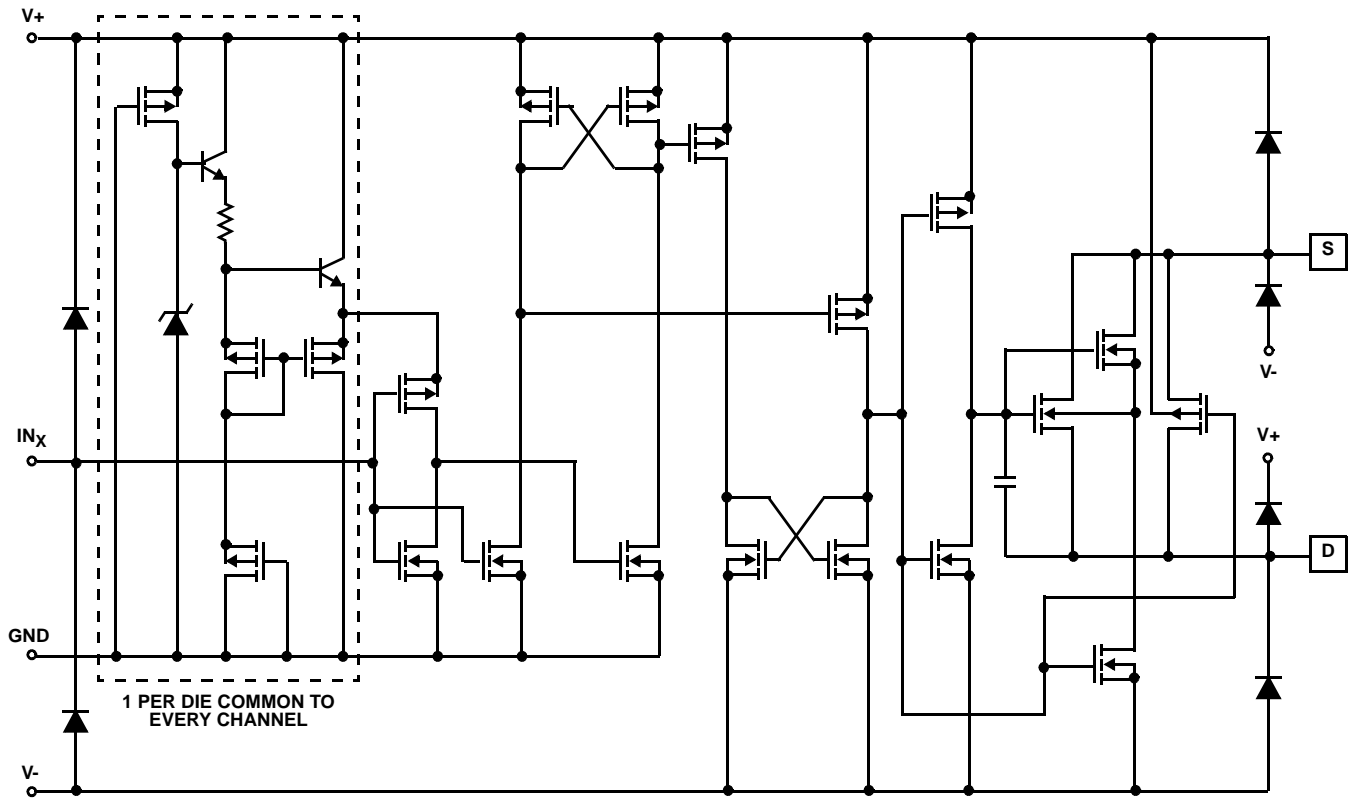

Pin Descriptions

PIN	SYMBOL	DESCRIPTION
1	IN ₁	Logic Control for Switch 1
2	D ₁	Drain (Output) Terminal for Switch 1
3	S ₁	Source (Input) Terminal for Switch 1
4	V-	Negative Power Supply Terminal
5	GND	Ground Terminal (Logic Common)
6	S ₄	Source (Input) Terminal for Switch 4
7	D ₄	Drain (Output) Terminal for Switch 4
8	IN ₄	Logic Control for Switch 4
9	IN ₃	Logic Control for Switch 3
10	D ₃	Drain (Output) Terminal for Switch 3
11	S ₃	Source (Input) Terminal for Switch 3
12	NC	No Internal Connection
13	V+	Positive Power Supply Terminal (Substrate)
14	S ₂	Source (Input) Terminal for Switch 2
15	D ₂	Drain (Output) Terminal for Switch 2
16	IN ₂	Logic Control for Switch 2

DG441, DG442

Absolute Maximum Ratings

V+ to V-	44.0V
GND to V-	25V
Digital Inputs, V _S , V _D (Note 1)	(V-) -2V to (V+) + 2V or 30mA, Whichever Occurs First
Continuous Current (Any Terminal)	30mA
Peak Current, S or D (Pulsed 1ms, 10% Duty Cycle Max)	100mA

Thermal Information

Thermal Resistance (Typical, Note 2)	θ_{JA} (°C/W)
PDIP Package	90
SOIC Package	115
Maximum Junction Temperature (Plastic Packages)	150°C
Maximum Storage Temperature Range	-65°C to 150°C
Maximum Lead Temperature (Soldering 10s) (SOIC - Lead Tips Only)	300°C

Operating Conditions

Temperature Range	-40°C to 85°C
Voltage Range	±20V (Max)
Input Low Voltage	0.8V (Max)
Input High Voltage	2.4V (Min)
Input Rise and Fall Time	≤20ns

CAUTION: Stresses above those listed in "Absolute Maximum Ratings" may cause permanent damage to the device. This is a stress only rating and operation of the device at these or any other conditions above those indicated in the operational sections of this specification is not implied.

NOTES:

- Signals on S_X, D_X or IN_X exceeding V+ or V- will be clamped by internal diodes. Limit forward diode current to maximum current ratings.
- θ_{JA} is measured with the component mounted on an evaluation PC board in free air.

Electrical Specifications (Dual Supply) Test Conditions: V+ = +15V, V- = -15V, V_{IN} = 2.4V, 0.8V, V_{ANALOG} = V_S, V_D, Unless Otherwise Specified

PARAMETER	TEST CONDITIONS	TEMP (°C)	MIN	(NOTE 3) TYP	MAX	UNITS
DYNAMIC CHARACTERISTICS						
Turn-ON Time, t _{ON}	R _L = 1k Ω , C _L = 35pF, V _S = ±10V, (Figure 1)	25	-	150	250	ns
Turn-OFF Time, t _{OFF}		25	-	90	120	ns
DG441				110	210	ns
Charge Injection, Q (Figure 2)	C _L = 1nF, V _G = 0V, R _G = 0 Ω	25	-	-1	-	pC
OFF Isolation (Figure 4)	R _L = 50 Ω , C _L = 5pF, f = 1MHz	25	-	60	-	dB
Crosstalk (Channel-to-Channel) (Figure 3)		25	-	-100	-	dB
Source OFF Capacitance, C _{S(OFF)}	f = 1MHz, V _{ANALOG} = 0 (Figure 5)	25	-	4	-	pF
Drain OFF Capacitance, C _{D(OFF)}		25	-	4	-	pF
Channel ON Capacitance, C _{D(ON)} + C _{S(ON)}		25	-	16	-	pF
DIGITAL INPUT CHARACTERISTICS						
Input Current V _{IN} Low, I _{IL}	V _{IN} Under Test = 0.8V, All Others = 2.4V	Full	-0.5	-0.00001	0.5	μ A
Input Current V _{IN} High, I _{IH}	V _{IN} Under Test = 2.4V, All Others = 0.8V	Full	-0.5	0.00001	0.5	μ A
ANALOG SWITCH CHARACTERISTICS						
Analog Signal Range, V _{ANALOG}		Full	-15	-	15	V
Drain-Source ON Resistance, r _{DS(ON)}	I _S = \mp 10mA, V _D = ±8.5V, V+ = 13.5V, V- = -13.5V	25	-	50	85	Ω
		85	-	-	100	Ω
Source OFF Leakage Current, I _{S(OFF)}	V+ = 16.5V, V- = -16.5V, V _D = ±15.5V, V _S = \mp 15.5V	25	-0.5	0.01	0.5	nA
		85	-5	-	5	nA
Drain OFF Leakage Current, I _{D(OFF)}		25	-0.5	0.01	0.5	nA
		85	-5	-	5	nA
Channel ON Leakage Current, I _{D(ON)} + I _{S(ON)}	V+ = 16.5V, V- = -16.5V, V _S = V _D = ±15.5V	25	-0.5	0.08	0.5	nA
		85	-10	-	10	nA
POWER SUPPLY CHARACTERISTICS						
Positive Supply Current, I+	V+ = 16.5V, V- = -16.5V, V _{IN} = 0V or 5V	Full	-	15	100	μ A
Negative Supply Current, I-		25	-1	-0.0001	-	μ A
		Full	-5	-	-	μ A
Ground Current, I _{GND}		Full	-100	-15	-	μ A

DG441, DG442

Electrical Specifications (Single Supply) Test Conditions: $V_+ = 12V$, $V_- = 0V$, $V_{IN} = 2.4V$, $0.8V$, Unless Otherwise Specified

PARAMETER	TEST CONDITIONS	TEMP (°C)	MIN	(NOTE 3) TYP	MAX	UNITS
DYNAMIC CHARACTERISTICS						
Turn-ON Time, t_{ON}	$R_L = 1k\Omega$, $C_L = 35pF$, $V_S = 8V$, (Figure 1)	25	-	300	450	ns
Turn-OFF Time, t_{OFF}		25	-	60	200	ns
Charge Injection, Q (Figure 2)	$C_L = 1nF$, $V_G = 6V$, $R_G = 0\Omega$	25	-	2	-	pC
ANALOG SWITCH CHARACTERISTICS						
Analog Signal Range, V_{ANALOG}		Full	0	-	12	V
Drain-Source ON Resistance, $r_{DS(ON)}$	$I_S = 10mA$, $V_D = 3V$, $8V$ $V_+ = 10.8V$	25	-	100	160	Ω
		Full	-	-	200	Ω
POWER SUPPLY CHARACTERISTICS						
Positive Supply Current, I_+	$V_+ = 13.2V$, $V_- = 0V$, $V_{IN} = 0V$ or $5V$	Full	-	15	100	μA
Negative Supply Current, I_-		25	-1	-0.0001	-	μA
		Full	-100	-0.0001	-	μA
Ground Current, I_{GND}		Full	-100	-15	-	μA

NOTES:

3. Typical values are for DESIGN AID ONLY, not guaranteed nor production tested.

Test Circuits and Waveforms

V_O is the steady state output with the switch on. Feedthrough via switch capacitance may result in spikes at the leading and trailing edge of the output waveform.

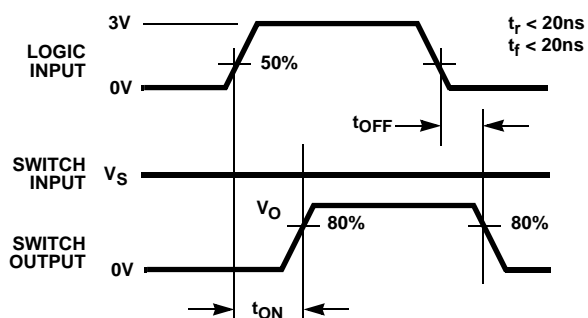

NOTE: Logic input waveform is inverted for switches that have the opposite logic sense.

FIGURE 1A. MEASUREMENT POINTS

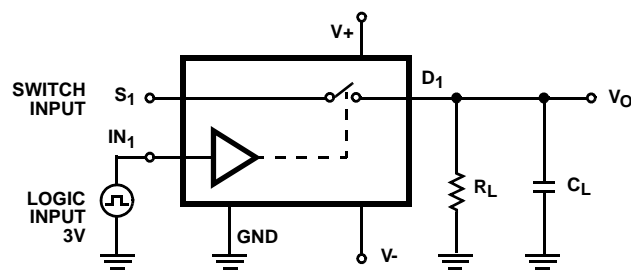

Repeat test for Channels 2, 3 and 4.
For load conditions, see Specifications. C_L includes fixture and stray capacitance.

$$V_O = V_S \frac{R_L}{R_L + r_{DS(ON)}}$$

FIGURE 1B. TEST CIRCUIT

FIGURE 1. SWITCHING TIMES

Test Circuits and Waveforms (Continued)

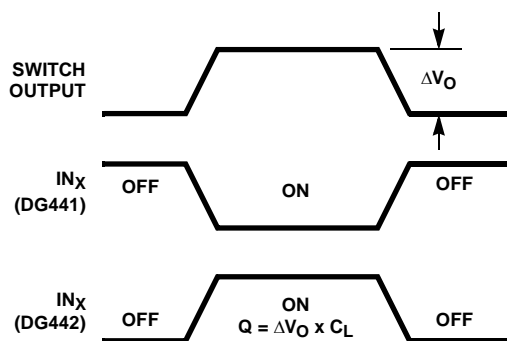

FIGURE 2A. MEASUREMENT POINTS

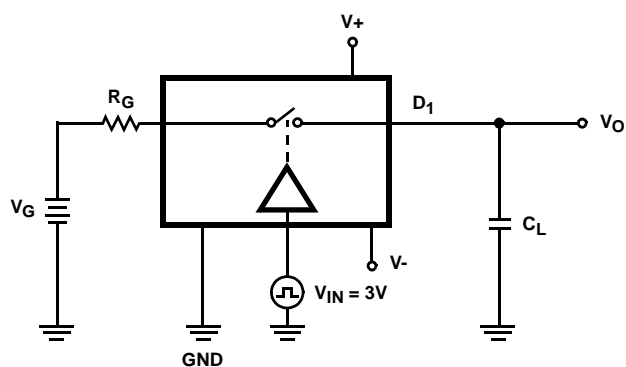

FIGURE 2B. TEST CIRCUIT

FIGURE 2. CHARGE INJECTION

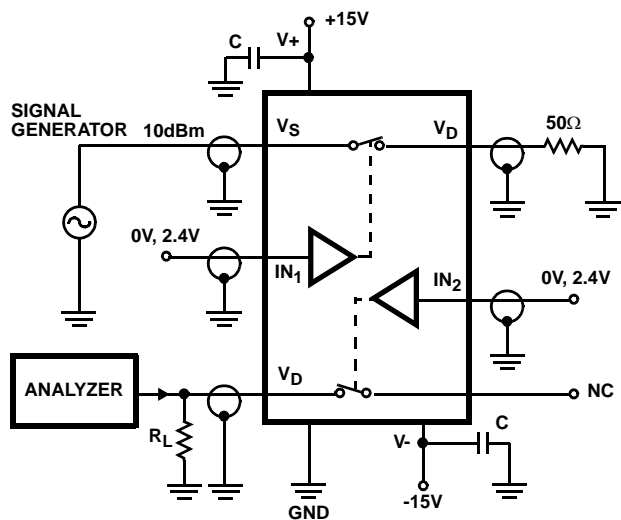

FIGURE 3. CROSTALK TEST CIRCUIT

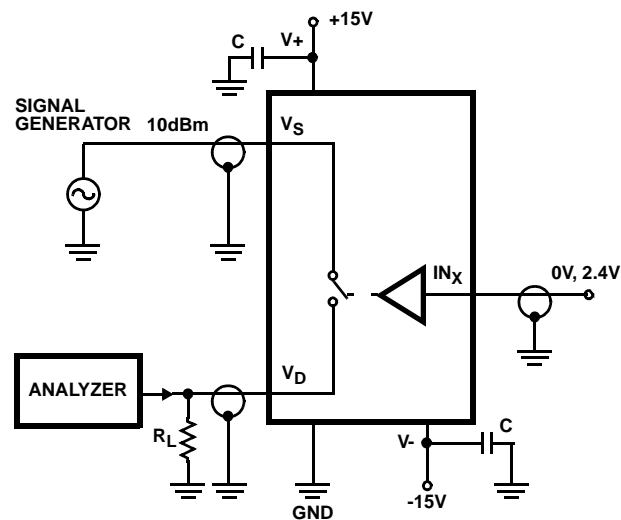

FIGURE 4. OFF ISOLATION TEST CIRCUIT

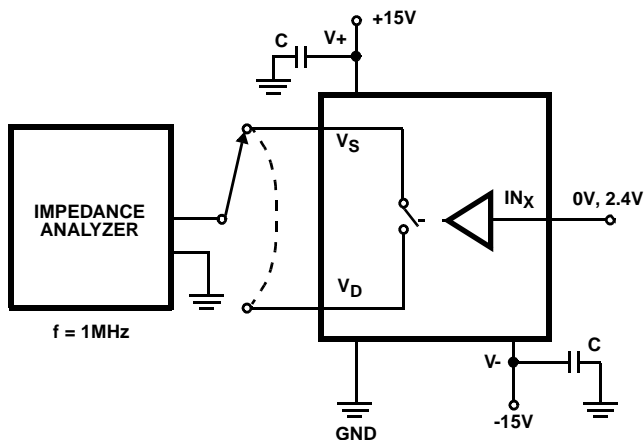
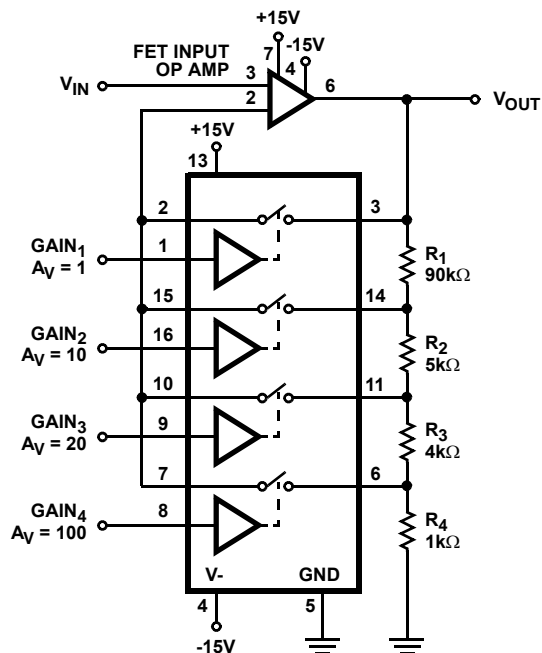

FIGURE 5. SOURCE/DRAIN CAPACITANCES TEST CIRCUIT

Application Information

GAIN ERROR IS DETERMINED ONLY BY THE RESISTOR TOLERANCE. OP AMP OFFSET AND CMRR WILL LIMIT ACCURACY OF CIRCUIT.



$$\frac{V_{OUT}}{V_{IN}} = \frac{R_1 + R_2 + R_3 + R_4}{R_4} = 100 \text{ with SW}_4 \text{ closed}$$

FIGURE 6. PRECISION WEIGHTED RESISTOR PROGRAMMABLE GAIN AMPLIFIER

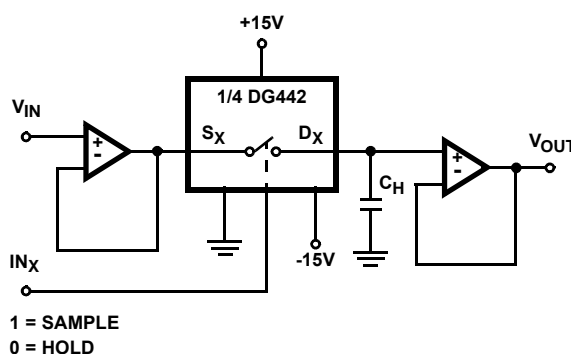

FIGURE 7. OPEN LOOP SAMPLE AND HOLD

Typical Performance Curves

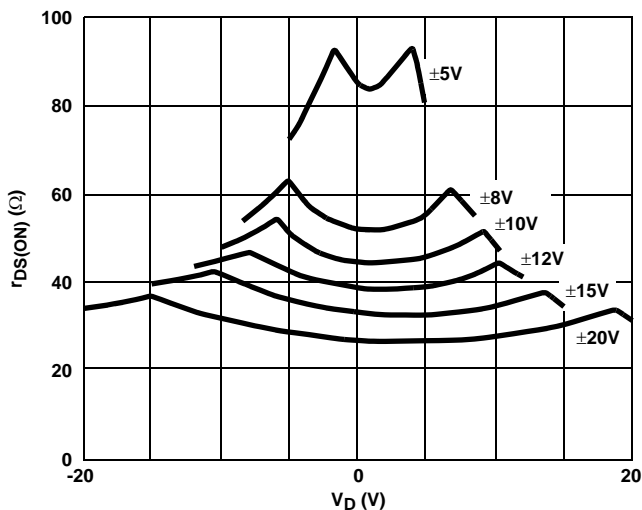

FIGURE 8. $r_{DS(ON)}$ vs V_D AND POWER SUPPLY VOLTAGE

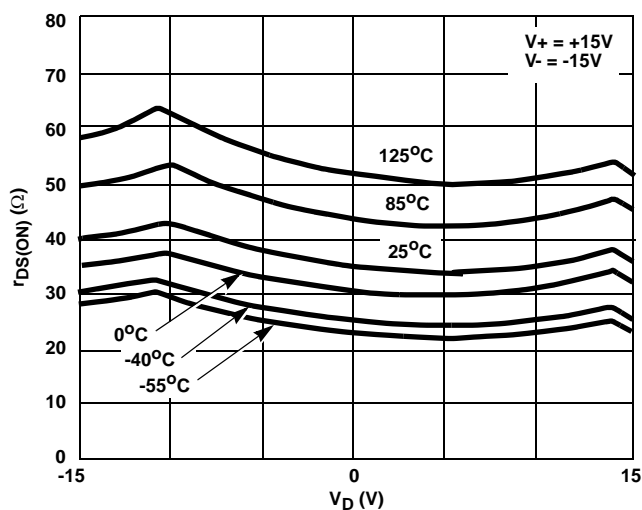

FIGURE 9. $r_{DS(ON)}$ vs V_D AND TEMPERATURE

Typical Performance Curves (Continued)

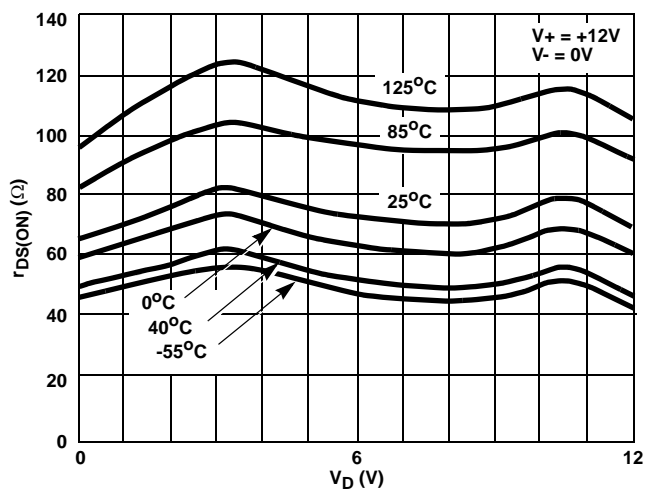

FIGURE 10. $r_{DS(ON)}$ vs V_D AND TEMPERATURE (SINGLE 12V SUPPLY)

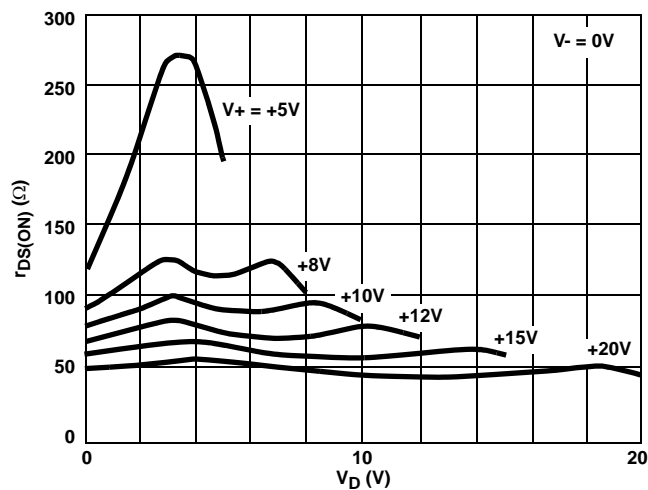

FIGURE 11. $r_{DS(ON)}$ vs V_D AND SINGLE SUPPLY VOLTAGE

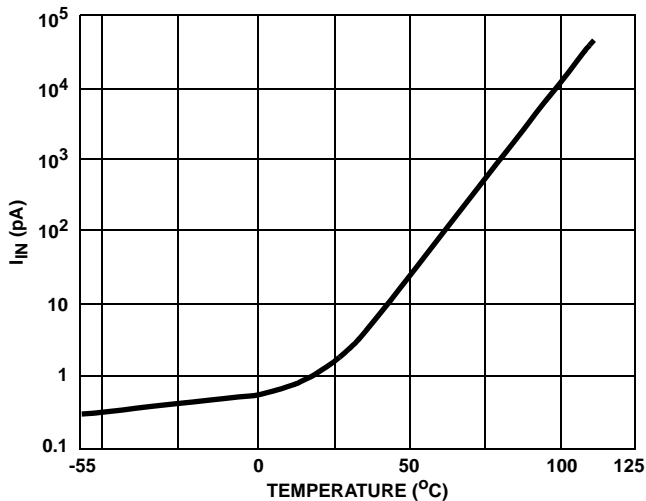

FIGURE 12. INPUT CURRENT vs TEMPERATURE

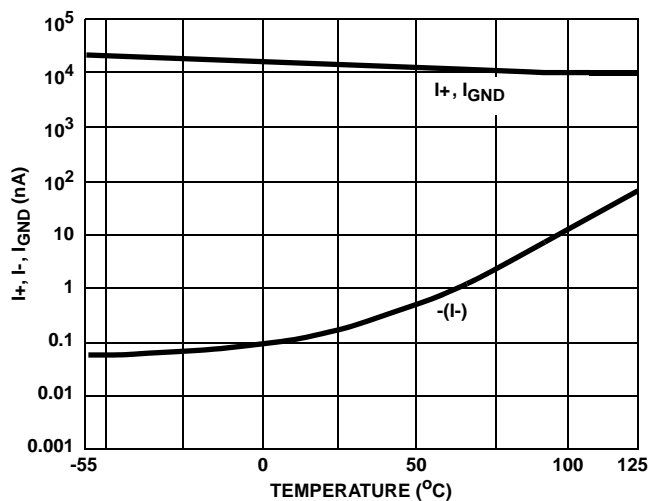

FIGURE 13. SUPPLY CURRENT vs TEMPERATURE

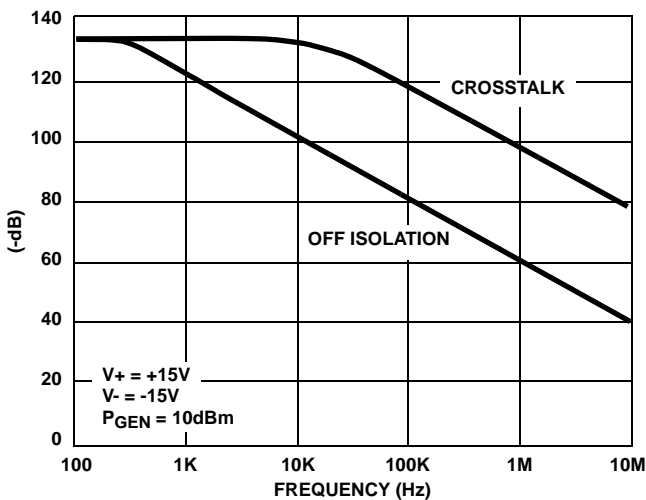

FIGURE 14. CROSSTALK AND OFF ISOLATION vs FREQUENCY

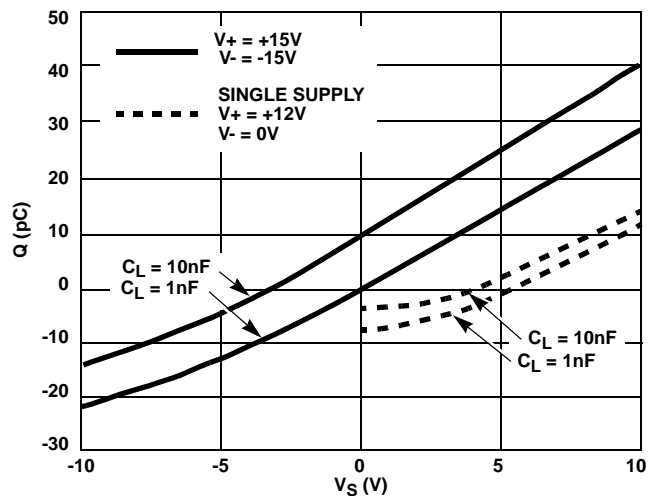

FIGURE 15. CHARGE INJECTION vs SOURCE VOLTAGE

DG441, DG442

Typical Performance Curves (Continued)

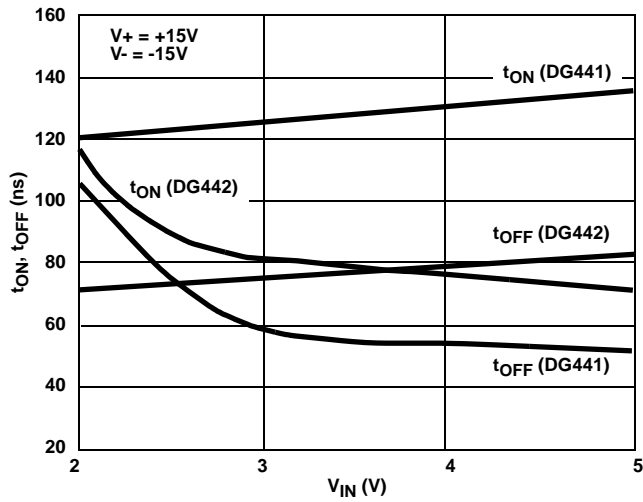

FIGURE 16. SWITCHING TIMES vs INPUT VOLTAGE

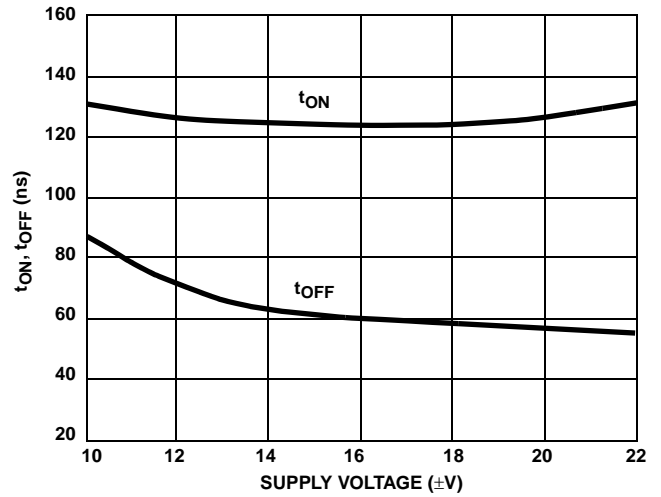

FIGURE 17. SWITCHING TIME vs POWER SUPPLY VOLTAGE (DG441)

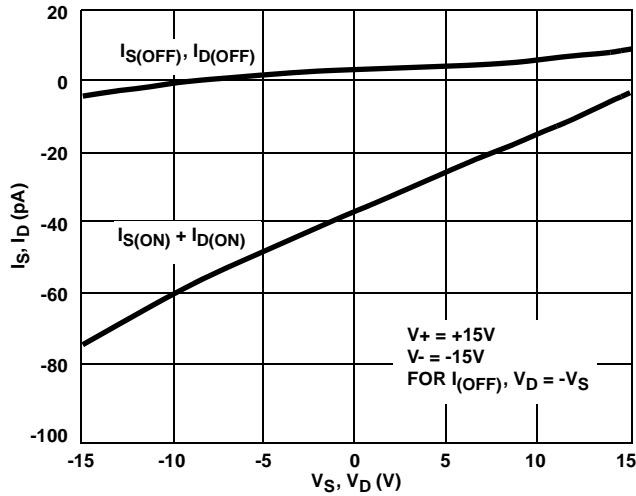

FIGURE 18. LEAKAGE CURRENT vs ANALOG VOLTAGE

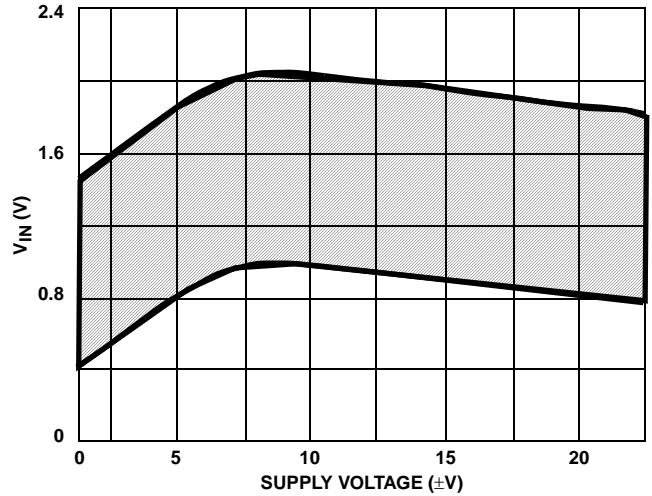

FIGURE 19. SWITCHING THRESHOLD vs SUPPLY VOLTAGE

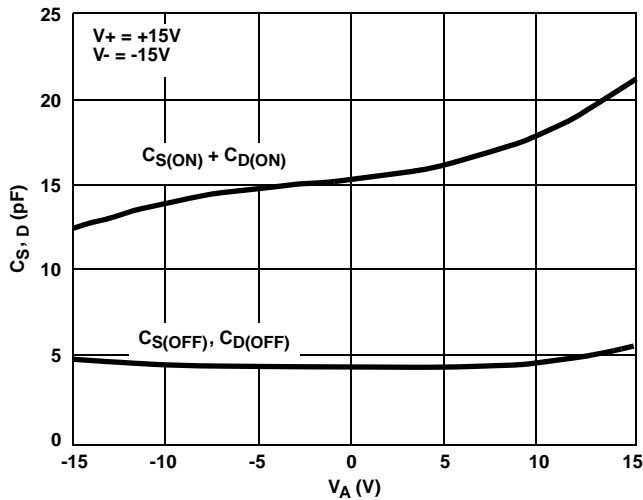

FIGURE 20. SOURCE/DRAIN CAPACITANCE vs ANALOG VOLTAGE

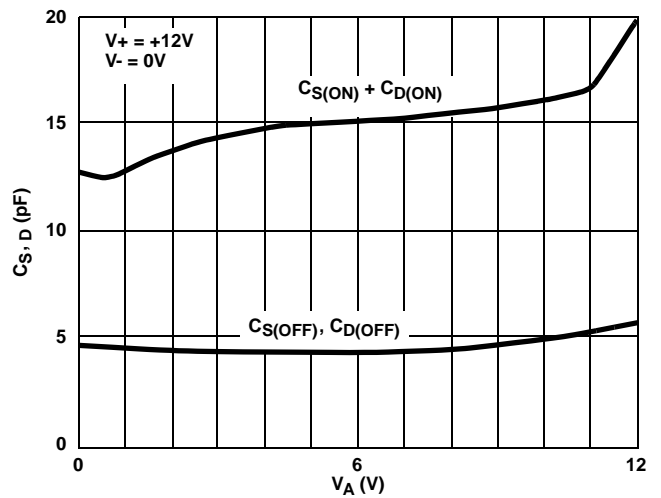

FIGURE 21. SOURCE/DRAIN CAPACITANCE vs ANALOG VOLTAGE (SINGLE 12V SUPPLY)

DG441, DG442

Typical Performance Curves (Continued)

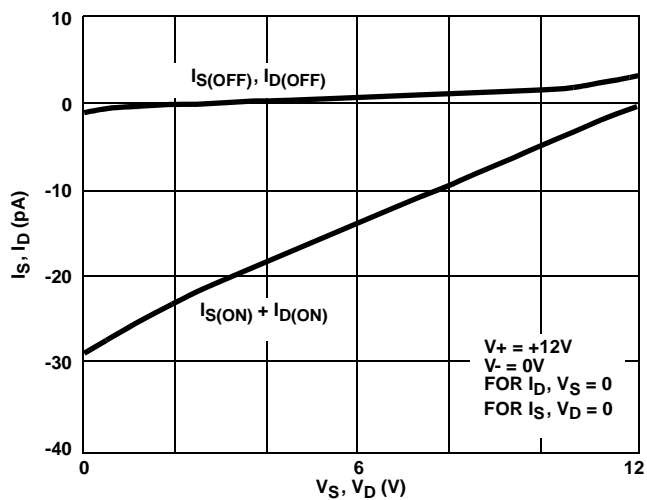

FIGURE 22. SOURCE/DRAIN LEAKAGE CURRENTS (SINGLE 12V SUPPLY)

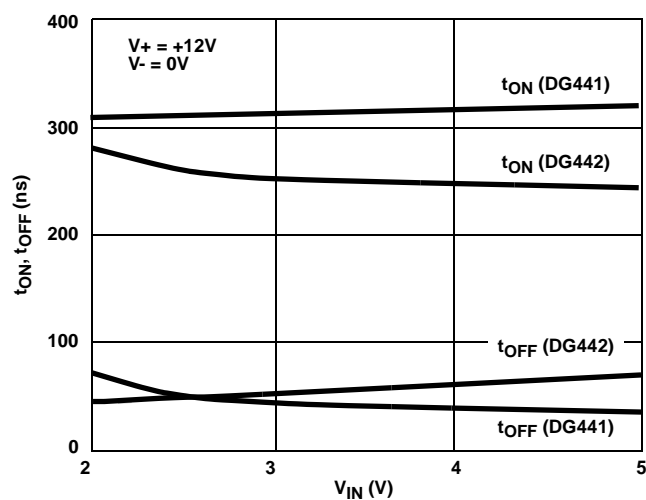

FIGURE 23. SWITCHING TIME vs INPUT VOLTAGE (SINGLE 12V SUPPLY)

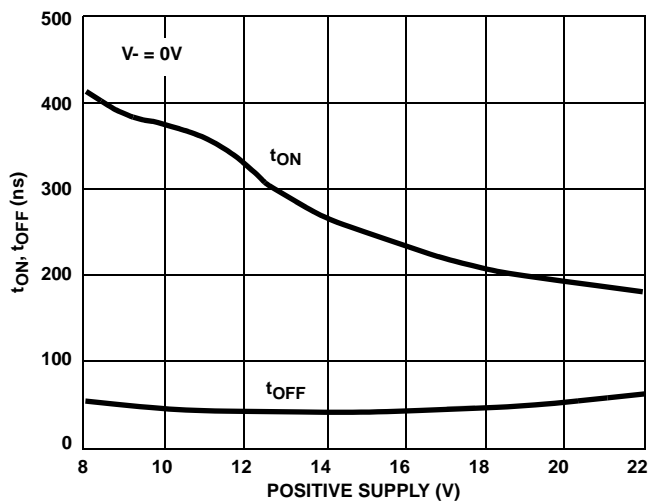

FIGURE 24. SWITCHING TIME vs SINGLE SUPPLY VOLTAGE (DG441)

DG441, DG442

Die Characteristics

DIE DIMENSIONS:

2160 μm x 1760 μm x 485 μm

METALLIZATION:

Type: SiAl

Thickness: 12k \AA \pm 1k \AA

PASSIVATION:

Type: Nitride

Thickness: 8k \AA \pm 1k \AA

WORST CASE CURRENT DENSITY:

9.1 x 10⁴ A/cm²

Metallization Mask Layout

DG441, DG442

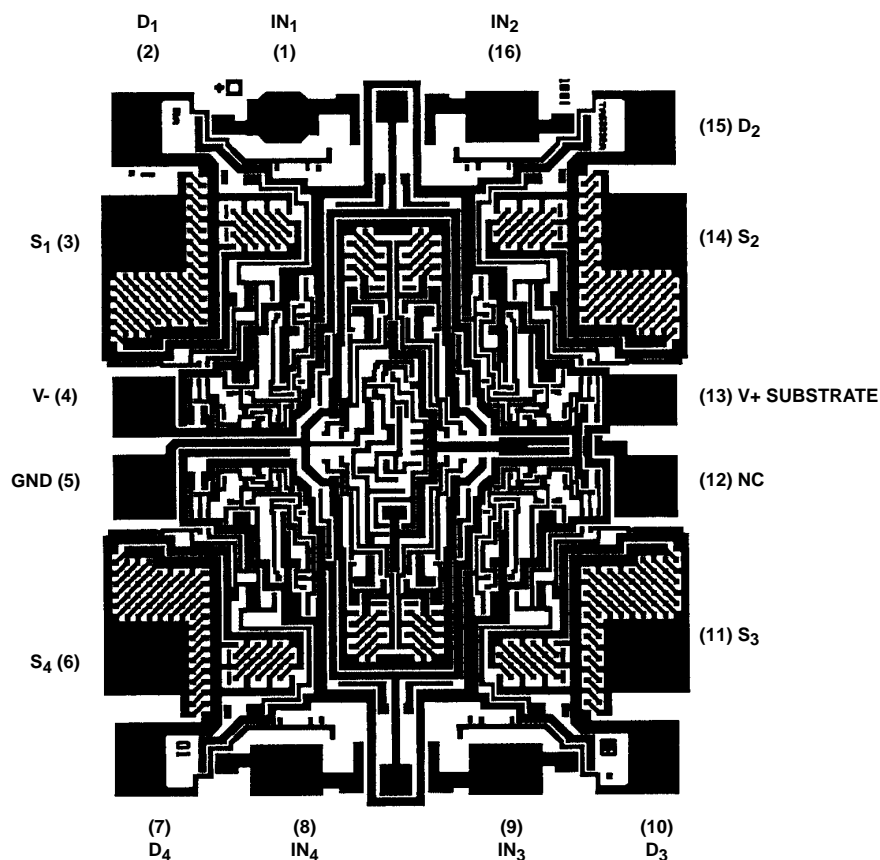

All Intersil U.S. products are manufactured, assembled and tested utilizing ISO9000 quality systems.

Intersil Corporation's quality certifications can be viewed at www.intersil.com/design/quality

Intersil products are sold by description only. Intersil Corporation reserves the right to make changes in circuit design, software and/or specifications at any time without notice. Accordingly, the reader is cautioned to verify that data sheets are current before placing orders. Information furnished by Intersil is believed to be accurate and reliable. However, no responsibility is assumed by Intersil or its subsidiaries for its use; nor for any infringements of patents or other rights of third parties which may result from its use. No license is granted by implication or otherwise under any patent or patent rights of Intersil or its subsidiaries.

For information regarding Intersil Corporation and its products, see www.intersil.com