



CYPRESS

CY2V9950

# 2.5/3.3V 200-MHz Multi-Output Zero Delay Buffer

## Features

- 2.5V or 3.3V operation
- Split output bank power supplies
- Output frequency range: 6 MHz to 200 MHz
- Output-output skew < 150 ps
- Cycle-cycle jitter < 100 ps
- Selectable positive or negative edge synchronization
- Selectable phase-locked loop (PLL) frequency range
- 8 LVTTTL outputs driving 50Ω terminated lines
- LVC MOS/LVTTTL Over-voltage tolerant reference input
- 2x, 4x multiply and (1/2)x, (1/4)x divide ratios
- Spread-Spectrum-compatible
- Pin-compatible with IDT5V9950 and IDT5T9950
- Industrial temperature range: -40°C to +85°C
- 32-pin TQFP package

## Functional Description

The CY2V9950 is a low-voltage, low-power, eight-output, 200-MHz clock driver. It features functions necessary to optimize the timing of high performance computer and communication systems.

The user can program the output banks through 3F[0:1] and 4F[0:1] pins. Any one of the outputs can be connected to feedback input to achieve different reference frequency multiplication and divide ratios and zero input-output delay.

The device also features split output bank power supplies which enable the user to run two banks (1Qn and 2Qn) at a power supply level different from that of the other two banks (3Qn and 4Qn). Additionally, the PE pin controls the synchronization of the output signals to either the rising or the falling edge of the reference clock.

## Block Diagram

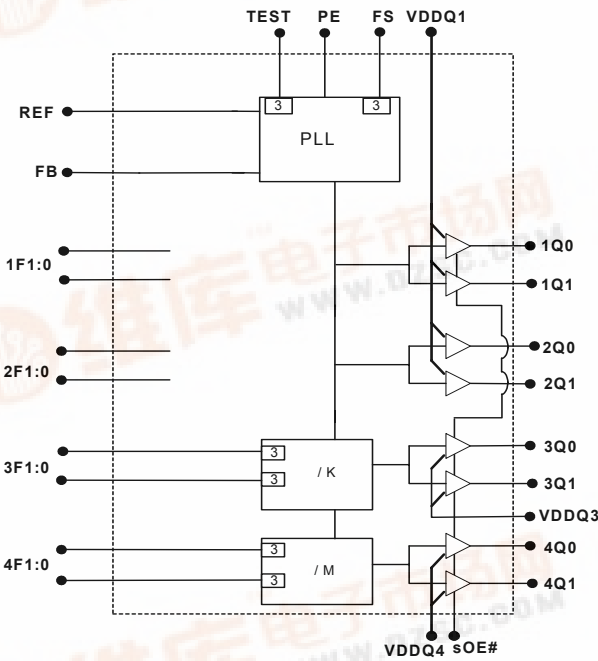

## Pin Configuration

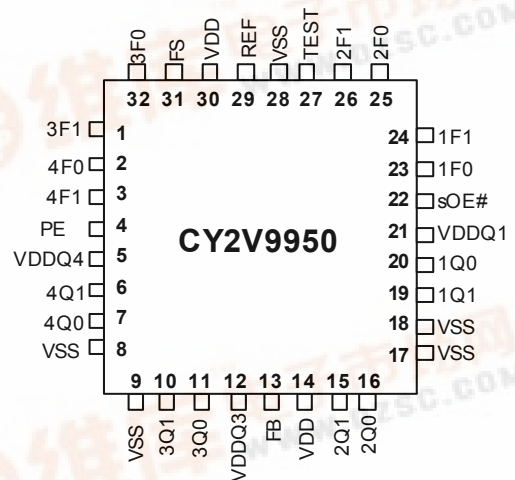

**Pin Definitions**

Pin	Name	I/O <sup>[1]</sup>	Type	Description
29	REF	I	LVTTTL/LVCMOS	<b>Reference Clock Input.</b>
13	FB	I	LVTTTL	<b>Feedback Input.</b>
27	TEST	I	3-Level	<b>When MID or HIGH, disables PLL (except for conditions of note 3).</b> REF goes to all outputs. Set LOW for normal operation.
22	sOE#	I, PD	2-Level	<b>Synchronous Output Enable.</b> When HIGH, it stops clock outputs (except 2Q0 and 2Q1) in a LOW state (for PE = H or M) – 2Q0 and 2Q1 may be used as the feedback signal to maintain phase lock. When TEST is held at MID level and sOE# is high, the nF[1:0] pins act as output disable controls for individual banks when nF[1:0] = LL. Set sOE# LOW for normal operation.
4	PE	I, PU	LVTTTL	<b>Selects Positive or Negative Edge Control and High or Low output drive strength.</b> When LOW / HIGH the outputs are synchronized with the negative/positive edge of the reference clock. Please see <i>Table 5</i> .
24, 23, 26, 25, 1, 32, 3, 2	nF[1:0]	I	3-Level	<b>Select frequency of the outputs.</b> Please see <i>Tables 1</i> and <i>2</i> .
31	FS	I	3-Level	<b>Selects VCO operating frequency range.</b> Please see <i>Table 4</i> .
19, 20, 15, 16, 10, 11, 6, 7	nQ[1:0]	O	LVTTTL	<b>Four banks of two outputs.</b> Please see <i>Tables 1</i> and <i>2</i> for frequency settings.
21	VDDQ1 <sup>[2]</sup>	PWR	Power	<b>Power supply for Bank 1 and Bank 2 output buffers.</b> Please see <i>Table 6</i> for supply level constraints
12	VDDQ3 <sup>[2]</sup>	PWR	Power	<b>Power supply for Bank 3 output buffers.</b> Please see <i>Table 6</i> for supply level constraints
5	VDDQ4 <sup>[2]</sup>	PWR	Power	<b>Power supply for Bank 4 output buffers.</b> Please see <i>Table 6</i> for supply level constraints
14, 30	VDD <sup>[2]</sup>	PWR	Power	<b>Power supply for internal circuitry.</b> Please see <i>Table 6</i> for supply level constraints
8, 9, 17, 18, 28	VSS	PWR	Power	<b>Ground.</b>

**Device Configuration**

The outputs of the CY2V9950 can be configured to run at frequencies ranging from 6 to 200 MHz. Banks 3 and 4 output dividers are controlled by 3F[1:0] and 4F[1:0] as indicated in *Table 1* and *2* respectively.

**Table 1. Output Divider Settings – Bank 3**

3F[1:0]	K – Bank3 Output Divider
LL <sup>[4]</sup>	2
HH	4
Other	1

**Table 2. Output Divider Settings – Bank 4**

4F[1:0]	M – Bank4 Output Divider
LL <sup>[4]</sup>	2
HH	Inverted <sup>[5]</sup>
Other	1

**Notes:**

- 'PD' indicates an internal pull-down and 'PU' indicates an internal pull-up. '3' indicates a three-level input buffer.
- A bypass capacitor (0.1µF) should be placed as close as possible to each positive power pin (<0.2"). If these bypass capacitors are not close to the pins their high frequency filtering characteristic will be cancelled by the lead inductance of the traces.
- When TEST = MID and sOE# = HIGH, PLL remains active with nF[1:0] = LL functioning as an output disable control for individual output banks. The 1F[0:1] and 2F[0:1] pins should be either tied to mid-level or left floating (on-chip resistors will bias to mid-level) during normal operation.
- LL disables outputs if TEST = MID and sOE# = HIGH.
- When 4Q[0:1] are set to run inverted (HH mode), sOE# disables these outputs HIGH when PE = HIGH, sOE# disables them LOW when PE = LOW.
- These outputs are undivided copies of the VCO clock. Therefore, the formulas in this column can be used to calculate the VCO operating frequency at a given reference frequency (F<sub>REF</sub>) and divider and feedback configurations. The user must select a configuration and a reference frequency that will generate a VCO frequency that is within the range specified by FS pin. Refer to *Table 4*.

The divider settings, output frequencies, and possible configurations of connecting FB to ANY output are summarized in *Table 3*.

**Table 3. Output Frequency Settings**

Configuration	Output Frequency		
FB to	1Q, 2Q <sup>[6]</sup>	3Q	4Q
1Qn, 2Qn	F <sub>REF</sub>	(1/K) x F <sub>REF</sub>	(1/M) x F <sub>REF</sub>
3Qn	K x F <sub>REF</sub>	F <sub>REF</sub>	(K/M) x F <sub>REF</sub>
4Qn	M x F <sub>REF</sub>	(M/K) x F <sub>REF</sub>	F <sub>REF</sub>

The 3-level FS control pin setting determines the nominal operating frequency range of the divide-by-one outputs of the device. The CY2V9950 PLL operating frequency range that corresponds to each FS level is given in *Table 4*.

**Table 4. Frequency Range Select**

FS	PLL Frequency Range
L	24 to 50 MHz
M	48 to 100 MHz
H	96 to 200 MHz

The PE pin determines whether the outputs synchronize to the rising edge or the falling edge of the reference signal, as indicated in *Table 5*.

**Table 5. PE Settings**

PE	Synchronization
L	Negative
H	Positive

The CY2V9950 features split power supply buses for Banks 1 and 2, Bank 3 and Bank 4, which enables the user to obtain both 3.3V and 2.5V output signals from one device. The core power supply (VDD) must be set a level which is equal or higher than that on any one of the output power supplies.

**Table 6. Power Supply Constraints**

VDD	VDDQ1 <sup>[7]</sup>	VDDQ3 <sup>[7]</sup>	VDDQ4 <sup>[7]</sup>
3.3V	3.3V or 2.5V	3.3V or 2.5V	3.3V or 2.5V
2.5V	2.5V	2.5V	2.5V

### Governing Agencies

The following agencies provide specifications that apply to the CY2V9950. The agency name and relevant specification is listed below.

Agency Name	Specification
JEDEC	JESD 51 (Theta JA)
	JESD 65 (Skew, Jitter)
IEEE	1596.3 (Jiter Specs)
UL-194_V0	94 (Moisture Grading)
MIL	883E Method 1012.1 (Therma Theta JC)

### Absolute Maximum Conditions

Parameter	Description	Condition	Min.	Max.	Unit
V <sub>DD</sub>	Operating Voltage	Functional @ 2.5V ± 5%	2.25	2.75	V
V <sub>DD</sub>	Operating Voltage	Functional @ 3.3V ± 10%	2.97	3.63	V
V <sub>IN(MIN)</sub>	Input Voltage	Relative to V <sub>SS</sub>	V <sub>SS</sub> - 0.3	-	V
V <sub>IN(MAX)</sub>	Input Voltage	Relative to V <sub>DD</sub>	-	V <sub>DD</sub> + 0.3	V
T <sub>S</sub>	Temperature, Storage	Non Functional	-65	+150	°C
T <sub>A</sub>	Temperature, Operating Ambient	Functional	-40	+85	°C
T <sub>J</sub>	Temperature, Junction	Functional	-	155	°C
ESD <sub>HBM</sub>	ESD Protection (Human Body Model)	MIL-STD-883, Method 3015	2000	-	V
∅ <sub>JC</sub>	Dissipation, Junction to Case	Mil-Spec 883E Method 1012.1	42	-	°C/W
∅ <sub>JA</sub>	Dissipation, Junction to Ambient	JEDEC (JESD 51)	105	-	°C/W
UL-94	Flammability Rating	@1/8 in.	V - 0	-	
MSL	Moisture Sensitivity Level		1	-	
F <sub>IT</sub>	Failure in Time	Manufacturing Testing	10	-	ppm

### DC Electrical Specifications @ 2.5V

Parameter	Description	Conditions	Min.	Max.	Unit
V <sub>DD</sub>	2.5 Operating Voltage	2.5V ± 5%	2.375	2.625	V
V <sub>IL</sub>	Input LOW Voltage	REF, FB, PE, and sOE# Inputs	-	0.7	V
V <sub>IH</sub>	Input HIGH Voltage		1.7	-	V
V <sub>IHH</sub> <sup>[8]</sup>	Input HIGH Voltage	3-Level Inputs (TEST, FS, nF[1:0]) (These pins are normally wired to VDD, GND or unconnected)	V <sub>DD</sub> - 0.4	-	V
V <sub>IMM</sub> <sup>[8]</sup>	Input MID Voltage		V <sub>DD</sub> /2 - 0.2	V <sub>DD</sub> /2 + 0.2	V
V <sub>ILL</sub> <sup>[8]</sup>	Input LOW Voltage		-	0.4	V
I <sub>IL</sub>	Input Leakage Current	V <sub>IN</sub> = V <sub>DD</sub> /G <sub>ND</sub> , V <sub>DD</sub> = Max (REF, PE, and FB inputs)	-5	5	µA

**Notes:**

- VDDQ1/3/4 must not be set at a level higher than that of VDD. They can be set at different levels from each other, e.g., VDD = 3.3V, VDDQ1 = 3.3V, VDDQ3 = 2.5V and VDDQ4 = 2.5V.
- These Inputs are normally wired to VDD, GND or unconnected. Internal termination resistors bias unconnected inputs to VDD/2.

**DC Electrical Specifications @ 2.5V** (continued)

I <sub>3</sub>	3-Level Input DC Current	HIGH, V <sub>IN</sub> = V <sub>DD</sub>	3-Level Inputs (TEST, FS, nF[1:0])	-	200	μA
		MID, V <sub>IN</sub> = V <sub>DD</sub> /2		-50	50	μA
		LOW, V <sub>IN</sub> = V <sub>SS</sub>		-200	-	μA
I <sub>PU</sub>	Input Pull-up Current	V <sub>IN</sub> = V <sub>SS</sub> , V <sub>DD</sub> = Max		-25	-	μA
I <sub>PD</sub>	Input Pull-down Current	V <sub>IN</sub> = V <sub>DD</sub> , V <sub>DD</sub> = Max, (sOE#)		-	100	μA
V <sub>OL</sub>	Output LOW Voltage	I <sub>OL</sub> = 12 mA (nQ[0:1])		-	0.4	V
V <sub>OH</sub>	Output HIGH Voltage	I <sub>OH</sub> = -12 mA (nQ[0:1])		2.0	-	V
I <sub>DDQ</sub>	Quiescent Supply Current	V <sub>DD</sub> = Max, TEST = MID, REF = LOW, sOE# = LOW, Outputs not loaded		-	2	mA
I <sub>DD</sub>	Dynamic Supply Current	@100 MHz		150		mA
C <sub>IN</sub>	Input Pin Capacitance			4		pF

**DC Electrical Specifications @ 3.3V**

Parameter	Description	Condition	Min.	Max.	Unit	
V <sub>DD</sub>	3.3 Operating Voltage	3.3V ± 10%	2.97	3.63	V	
V <sub>IL</sub>	Input LOW Voltage	REF, FB, PE, and sOE# Inputs	-	0.8	V	
V <sub>IH</sub>	Input HIGH Voltage		2.0	-	V	
V <sub>IHH</sub> <sup>[8]</sup>	Input HIGH Voltage	3-Level Inputs (TEST, FS, nF[1:0]) (These pins are normally wired to V <sub>DD</sub> , GND or unconnected)	V <sub>DD</sub> - 0.6	-	V	
V <sub>IMM</sub> <sup>[8]</sup>	Input MID Voltage		V <sub>DD</sub> /2 - 0.3	V <sub>DD</sub> /2 + 0.3	V	
V <sub>ILL</sub> <sup>[8]</sup>	Input LOW Voltage		-	0.6	V	
I <sub>IL</sub>	Input Leakage Current	V <sub>IN</sub> = V <sub>DD</sub> /G <sub>ND</sub> , V <sub>DD</sub> = Max (REF, PE, and FB inputs)	-5	5	μA	
I <sub>3</sub>	3-Level Input DC Current	HIGH, V <sub>IN</sub> = V <sub>DD</sub>	3-Level Inputs (TEST, FS, nF[1:0])	-	200	μA
		MID, V <sub>IN</sub> = V <sub>DD</sub> /2		-50	50	μA
		LOW, V <sub>IN</sub> = V <sub>SS</sub>		-200	-	μA
I <sub>PU</sub>	Input Pull-Up Current	V <sub>IN</sub> = V <sub>SS</sub> , V <sub>DD</sub> = Max		-100	-	μA
I <sub>PD</sub>	Input Pull-Down Current	V <sub>IN</sub> = V <sub>DD</sub> , V <sub>DD</sub> = Max, (sOE#)		-	100	μA
V <sub>OL</sub>	Output LOW Voltage	I <sub>OL</sub> = 12 mA, (nQ[0:1])		-	0.4	V
V <sub>OH</sub>	Output HIGH Voltage	I <sub>OH</sub> = -12 mA, (nQ[0:1])		2.4	-	V
I <sub>DDQ</sub>	Quiescent Supply Current	V <sub>DD</sub> = Max, TEST = MID, REF = LOW, sOE# = LOW, outputs not loaded		-	2	mA
I <sub>DD</sub>	Dynamic Supply Current	@100 MHz		230		mA
C <sub>IN</sub>	Input Pin Capacitance			4		pF

**AC Input Specifications**

Parameter	Description	Condition	Min.	Max.	Unit
T <sub>R</sub> , T <sub>F</sub>	Input Rise/Fall Time	0.8V - 2.0V	-	10	ns/V
T <sub>PWC</sub>	Input Clock Pulse	HIGH or LOW	2	-	ns
T <sub>DCIN</sub>	Input Duty Cycle		10	90	%
F <sub>REF</sub>	Reference Input Frequency	FS = LOW	6	50	MHz
		FS = MID	12	100	
		FS = HIGH	24	200	

**Switching Characteristics**

Parameter	Description	Condition	Min.	Max.	Unit
F <sub>OR</sub>	Output frequency range		6	200	MHz
VCO <sub>LR</sub>	VCO Lock Range		200	400	MHz
VCO <sub>LBW</sub>	VCO Loop Bandwidth		0.25	3.5	MHz
t <sub>SKREWPR</sub>	Matched-Pair Skew <sup>[9]</sup>	Skew between the earliest and the latest output transitions within the same bank	–	150	ps
t <sub>SKEW0</sub>	Output-Output Skew <sup>[9]</sup>	Skew between the earliest and the latest output transitions among all outputs	–	200	ps
t <sub>SKEW1</sub>		Skew between the earliest and the latest output transitions among all same class outputs	–	200	ps
t <sub>SKEW2</sub>		Skew between the nominal output rising edge to the inverted output falling edge	–	500	ps
t <sub>SKEW3</sub>		Skew between non-inverted outputs running at different frequencies	–	500	ps
t <sub>SKEW4</sub>		Skew between nominal to inverted outputs running at different frequencies	–	500	ps
t <sub>SKEW5</sub>		Skew between nominal outputs at different power supply levels	–	650	ps
t <sub>PART</sub>	Part-Part Skew	Skew between the outputs of any two devices under identical settings and conditions (VDDQ, VDD, temp, air flow, frequency, etc.)	–	750	ps
t <sub>PD0</sub>	Ref to FB Propagation Delay <sup>[10]</sup>		–250	+250	ps
t <sub>ODCV</sub>	Output Duty Cycle	Measured at VDD/2	45	55	%
t <sub>PWH</sub>	Output High Time Deviation from 50%	Measured at 2.0V for VDD = 3.3V and at 1.7V for VDD = 2.5V.	–	1.5	ns
t <sub>PWL</sub>	Output Low Time Deviation from 50%	Measured at 0.8V for VDD = 3.3V and at 0.7V for VDD = 2.5V.	–	2.0	ns
t <sub>R/t<sub>F</sub></sub>	Output Rise/Fall Time	Measured at 0.8V – 2.0V for VDD = 3.3V and 0.7V – 1.7V for VDD = 2.5V	0.15	1.5	ns
t <sub>LOCK</sub>	PLL lock time <sup>[11,12]</sup>		–	0.5	ms
t <sub>CCJ</sub>	Cycle-Cycle Jitter	Divide by 1 output frequency, FS = L, FB = divide by 1, 2, 4	–	100	ps
		Divide by 1 output frequency, FS = M/H, FB = divide by 1, 2, 4	–	150	ps

**Notes:**

9. Test Load = 20 pF, terminated to VCC/2. All outputs are equally loaded.
10. t<sub>PD</sub> is measured at 1.5V for VDD = 3.3V and at 1.25V for VDD = 2.5V with REF rise/fall times of 0.5ns between 0.8V–2.0V.
11. t<sub>LOCK</sub> is the time that is required before outputs synchronize to REF. This specification is valid with stable power supplies which are within normal operating limits.
12. Lock detector circuit may be unreliable for input frequencies lower than 4MHz, or for input signals which contain significant jitter.

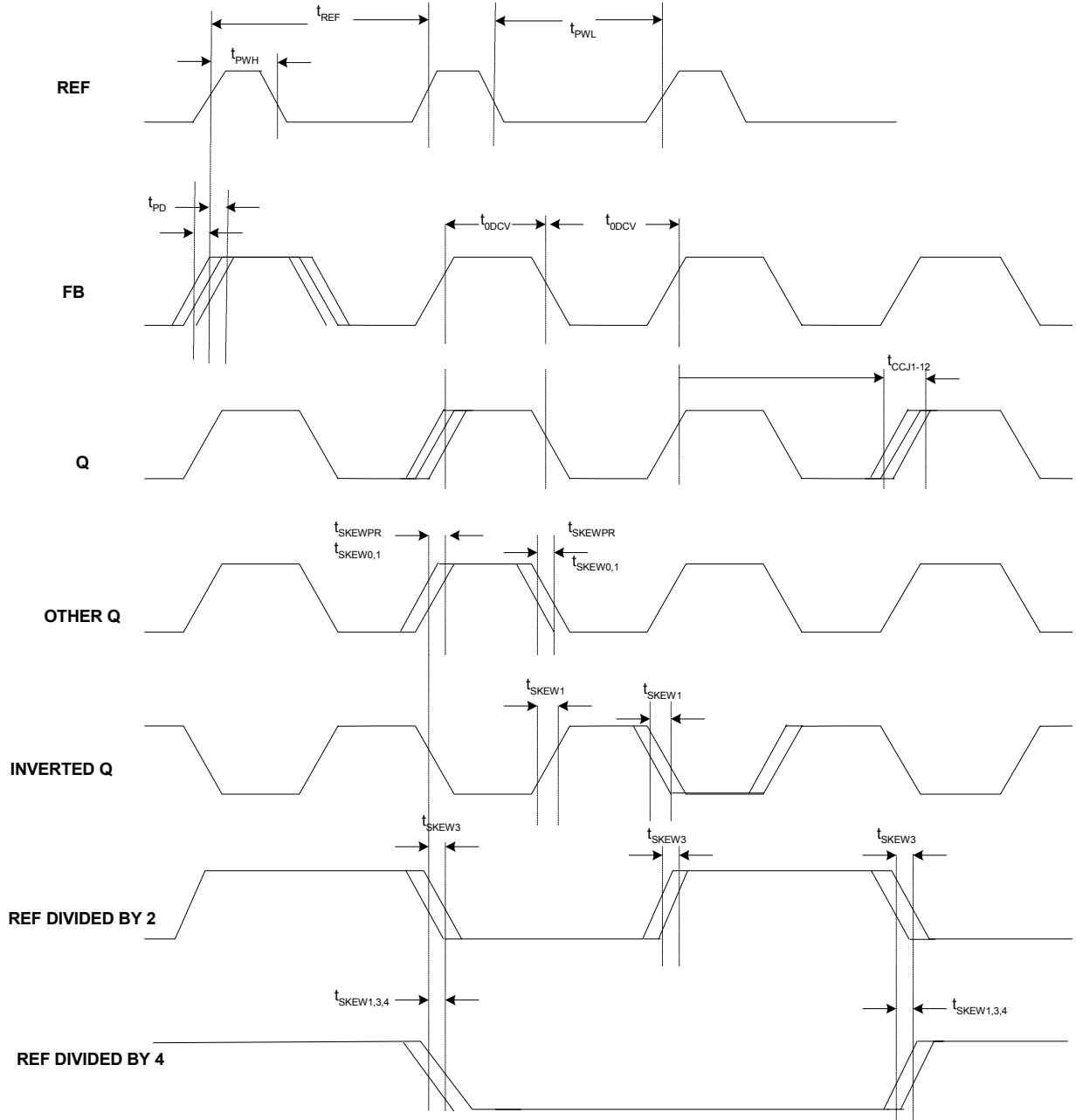
**AC Timing Definitions**

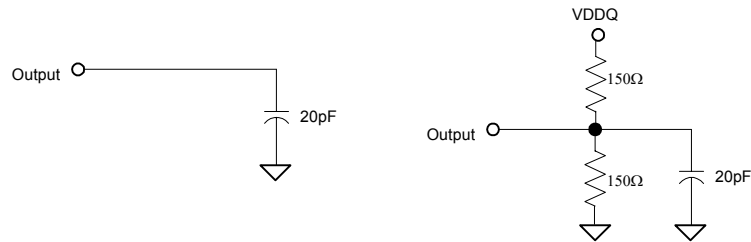
**AC Test Loads and Waveforms**

For Lock Output

For All Other Outputs

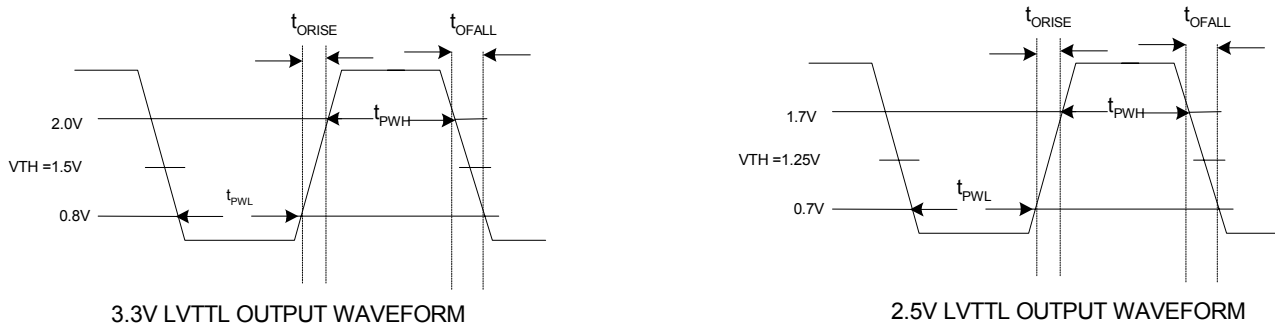
**Figure 1.**

3.3V LVTTTL OUTPUT WAVEFORM

2.5V LVTTTL OUTPUT WAVEFORM

**Figure 2. LVTTTL Output Test Waveforms**

3.3V LVTTTL INPUT TEST WAVEFORM

2.5V LVTTTL INPUT TEST WAVEFORM

**Figure 3. LVTTTL Input Test Waveforms**
**Ordering Information**

Part Number	Package Type	Product Flow
CY2V9950AC	32 TQFP	Commercial, 0° to 70°C
CY2V9950ACT	32 TQFP – Tape and Reel	Commercial, 0° to 70°C
CY2V9950AI	32 TQFP	Industrial, –40° to 85°C
CY2V9950AIT	32 TQFP – Tape and Reel	Industrial, –40° to 85°C

Package Drawing and Dimensions

32-lead Thin Plastic Quad Flatpack 7 x 7 x 1.0 mm A32

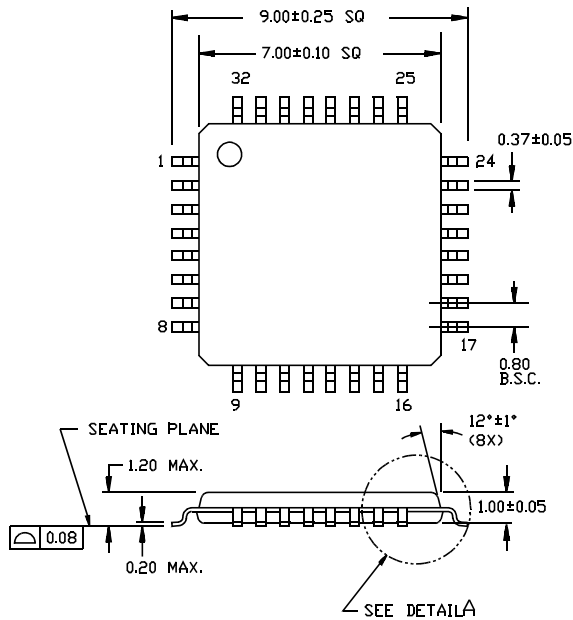

DIMENSIONS ARE IN MILLIMETERS

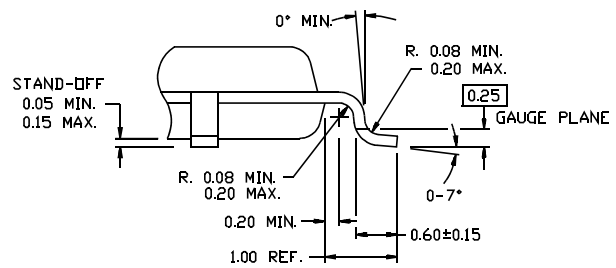

DETAIL A

51-85063-B

All product and company names mentioned in this document are the trademarks of their respective holders.





**Document History Page**

<b>Document Title: CY2V9950 2.5/3.3V 200-MHz Multi-Output Zero Delay Buffer</b> <b>Document Number: 38-07436</b>				
<b>REV.</b>	<b>ECN No.</b>	<b>Issue Date</b>	<b>Orig. of Change</b>	<b>Description of Change</b>
**	122628	01/10/03	RGL	New Data Sheet
*A	252355	See ECN	RGL/GGK	Fixed Note 3 definition.



中发网 WWW.ZFA.CN

全球最大的PDF中文下载站



**中发网**  
www.zfa.cn

**PDF 资料下载尽在中发网**