



CYPRESS

ComLink™ Series
CY2LL843

High-drive Two-Channel LVDS Repeater/Mux

Features

- ANSI TIA/EIA-644-1995-compliant
- Designed for data rates to ≥ 700 Mbs = (350 MHz)
- Single 2×2 with high-drive output drivers
- Low-voltage differential signaling with output voltages of ± 350 mV into 50-ohm load version (Bus LVDS)
- Single 3.3V supply
- Accepts ± 350 -mV differential inputs
- Output Drivers are high-impedance when disabled or when $V_{DD} \leq 1.5V$
- 16-pin SOIC/TSSOP packages
- Industrial version available

Description

The Cypress CY2LL843 are differential line drivers and receivers that utilize Low Voltage Signaling or LVDS, to

achieve signaling rates of 700Mbs. The receiver outputs can be switched to either or both drivers through the multiplexer control signals S0/S1. This provides flexibility in application for either a splitter or router configuration with a single device.

The Cypress CY2LL843 are configured as a single two-channel repeater/Mux.

The LVDS standard provides a minimum differential output voltage of 247 mV into a 50-ohm load and receipt of as little as 100 mV signals with up to 1V of DC offset between transmitter and receiver. The Cypress CY2LL843 doubles the output drive current to achieve BusLVDS signaling levels with a faster rise/fall times into 50-ohm load.

A doubly terminated BusLVDS line enables multipoint configurations.

Designed for both point to point based-band multi-point data transmission over controlled impedance lines.

Block Diagram

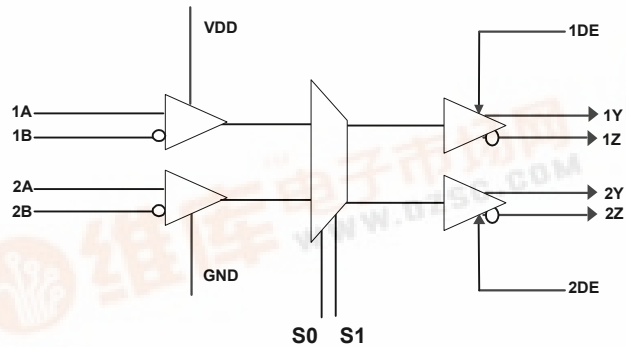

Pin Configuration

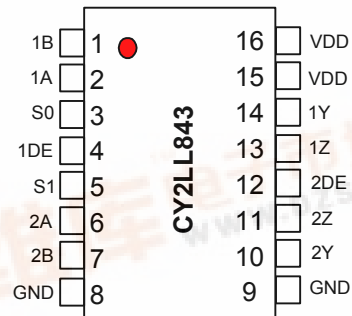

16 pin SOIC/TSSOP





Pin Description

Pin Number	Pin Name	Pin Description
1,2	1B, 1A	Differential Input Channel 1
3	S0	Function Select 0
4	1DE	Data Enable Channel 1
5	S1	Function Select 1
6,7	2A, 2B	Differential Input Channel 2
8,9	GND	Ground
10,11	2Y, 2Z	Differential Output Channel 2
12	2DE	Data Enable Channel 2
14,13	1Y, 1Z	Differential Output Channel 1
15,16	V _{DD}	Supply Voltage

Table 1. Mux Function Table

Input		Output ^[1]		Function
S0	S1	1Y/1Z	2Y/2Z	
0	0	1A/1B	1A/1B	Splitter A
1	0	2A/2B	2A/2B	Splitter B
0	1	1A/1B	2A/2B	Pass-thru Router
1	1	2A/2B	1A/1B	Cross Point Router

Table 2. Absolute Maximum Rating Over Operating Free-Air Temperature^[2]

Supply Voltage Range, V _{DD} (1)	-0.5V to 4V
Voltage Range (DE,S0,S1)	-0.5V to 6.0V
Input Voltage Range, V _{IN} (A or B)	-0.5V to V _{DD} + 0.5V
ESD (All pins)	Class 3, A: 2KV, B: 500V
Storage Temperature Range	-65°C to 150°C

Table 3. Recommended Operating Conditions^[3]

Parameter	Description	Min.	Typ.	Max.	Unit
V _{DD}	Supply Voltage	3	3.3	3.6	V
V _{IH}	High Level Input Voltage (S0,S1,1DE,2DE)	2			
V _{IL}	Low Level Input Voltage (S0,S1,1DE,2DE)			0.8	
V _{ID}	Magnitude of Differential Input Voltage	0.1		0.6	
V _{IC}	Common Mode Input Voltage (see Figure 11,Figure 12, Figure 13)	V _{ID} /2		2.4 - (V _{ID} /2)	
				V _{DD} - 0.8	
T _A	Operating Free Air Temperature	-40		85	°C

Notes:

- See Figure 1.
- Stresses greater than those listed under absolute maximum ratings may cause permanent damage to the device. This is intended to be a stress rating only and functional operation of the device at these or any other conditions above those indicated in the operation sections of this specification is not implied. Exposure to absolute maximum rating conditions for extended periods may affect reliability.
- Multiple Supplies:** The voltage on any input or I/O pin cannot exceed the power pin during power-up. Power supply sequencing is NOT required



Table 4. Receiver Electrical Characteristics Over Recommended Operating Conditions

Parameter	Description	Test Conditions	Min.	Typ.	Max.	Unit
VITH+	Positive-going Differential Input Voltage Threshold	$V_{CM} = 1.2V$			100	mV
VITH-	Negative-going Differential Input Voltage Threshold	$V_{CM} = 1.2V$	-100			mV
II	Input Current (A Inputs)	$V_I = 0V$	-0.5		-10	uA
		$V_I = 2.4V$			-10	uA
II	Input Current (B Inputs)	$V_I = 0.8V$	0.5		10	uA
		$V_I = 2.4V$			10	uA
II (Off)	Power Off Current (A or B Inputs)	$V_{DD} = 0V$		0.1	10	uA

Table 5. Receiver Electrical Characteristics Over Recommended Operating Conditions

Parameter	Description	Test Conditions		Min.	Typ.	Max.	Unit
V_{OD}	Differential Output Voltage Swing	RL = 50 Ohm	See Figure 11, Figures [15]–[19]	247	340	454	mV
$\sim V_{OD}$	Change in differential Output Voltage Swing between logic states			-50		50	mV
$V_{OC(SS)}$	Steady State Common-mode output voltage		See Figure 12	1.125		1.375	V
$\sim V_{OC(SS)}$	Change in Steady State Common-mode output between logic states			-50	3	50	mV
$V_{OC(PP)}$	Peak to Peak Common-mode output voltage				150	mV	
I_{CC}	Supply Current	No load f = 100 MHz				30	mA
		RL = 50 ohm, F = 100 MHz				35	mA
		Both Channels Disabled				25	mA
I_H	High Level Input Current	S0,S1,DE	$V_{IH} = 5V$		20		uA
I_{IL}	Low Level Input Current	S0,S1,DE	$V_{IL} = 0.8V$		5		uA
I_{OS}	Short Circuit Current	V_{OY} or $V_{OZ} = 0V$				20	mA
		$V_{OD} = 0V$				20	mA
I_{OZ}	High Impedance Output Current	$V_{OD} = 60mV$			0.1	1	uA
		$V_O = 0V$ or V_{DD}			0.1	1	uA
C_{in}	Input Capacitance	1A, 1B, 2A, 2B			3		pF
	Control Input Capacitance	S0, S1, 1DE, 2DE			8		pF

Table 6. Differential Receiver to Driver Switching Characteristics Over Recommended Operating Conditions ^[5]

Parameter	Description	Test Conditions	Min.	Typ. ^[4]	Max.	Unit	
T_{PLH}	Differential Propagation delay, Low to High	CL = 10 pF (see Figure 14)		4	6	nS	
T_{PHL}	Differential Propagation delay, High to Low			4	6	nS	
$T_{sk(p)}$	Pulse Skew ($T_{PHL} - T_{PLH}$)				0.2		nS
T_r	Transition Low to High				800	1500	pS
T_f	Transition High to Low				800	1500	pS

Notes:

- All typical values are measured at 25°C with a 3.3V supply.
- These parameters are measured over supply voltage and temperature ranges recommended for the device.

Table 6. Differential Receiver to Driver Switching Characteristics Over Recommended Operating Conditions (continued)^[5]

T _{PHZ}	Propagation delay, High level to High impedance output	(see Figure 14)		4	10	nS
T _{PLZ}	Propagation delay, Low level to High impedance output			4.3	10	nS
T _{PZH}	Propagation delay, high impedance to High level output			3	10	nS
T _{PZL}	Propagation delay, high impedance to Low level output			2	10	nS
T _{PHL_skR1_Dx}	Channel to Channel skew-receiver 1 to Any mux related drivers			95		pS
T _{PLH_skR1_Dx}	Channel to Channel skew-receiver 1 to Any mux related drivers			95		pS
T _{PPHL_skR2_Dx}	Channel to Channel skew-receiver 2 to Any mux related drivers			95		pS
T _{PLH_skR2_Dx}	Channel to Channel skew-receiver 2 to Any mux related drivers			95		pS
D _J	Deterministic Jitter (100MHz, 25°C, VID = 0.4V, S0, S1 = 0)	(see Figure 7) PRBS-Differential		95		pS

Table 7. High Frequency Parametrics

Parameter	Description	Test Conditions	Min.	Typ.	Max.	Unit
F _{max}	Maximum frequency V _{DD} = 3.3V	50% duty cycle tW(50–50) Standard Load Circuit.			400	MHz

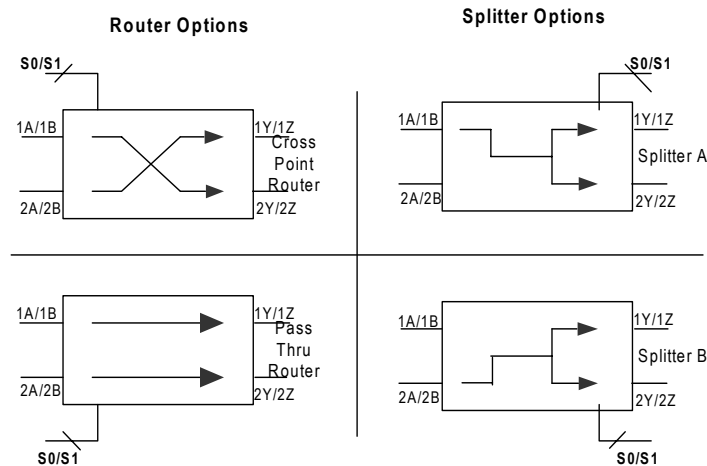
Figure 1. Two-channel Cross Point Switch/Mux

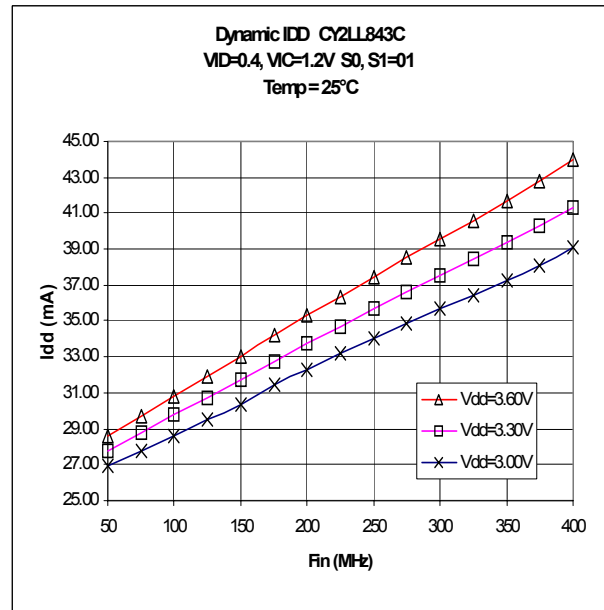
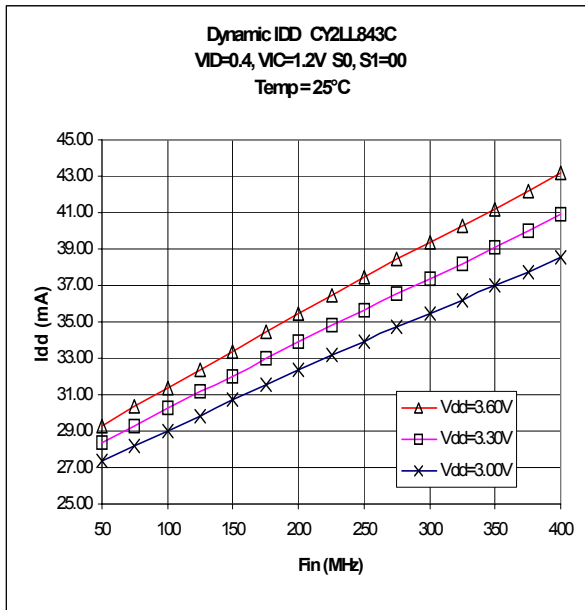

Figure 2. Dynamic IDD vs. Frequency 25 C

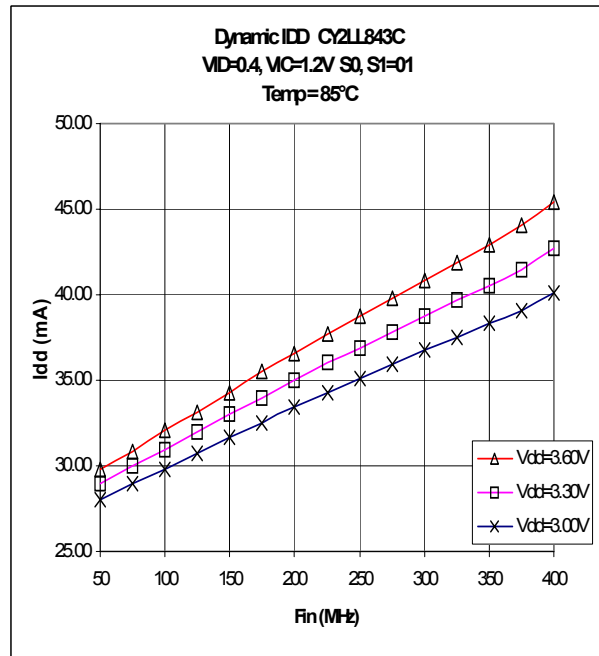
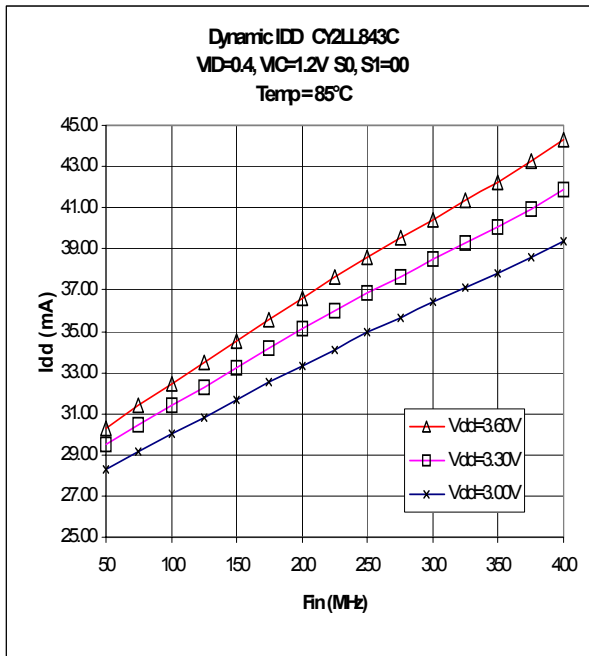

Figure 3. Dynamic IDD vs. Frequency 85 C

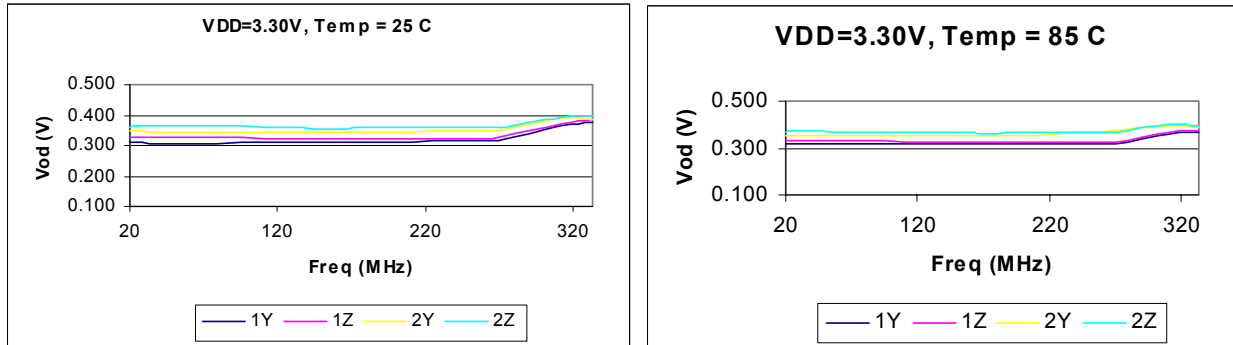

Figure 4. VOD vs. Frequency

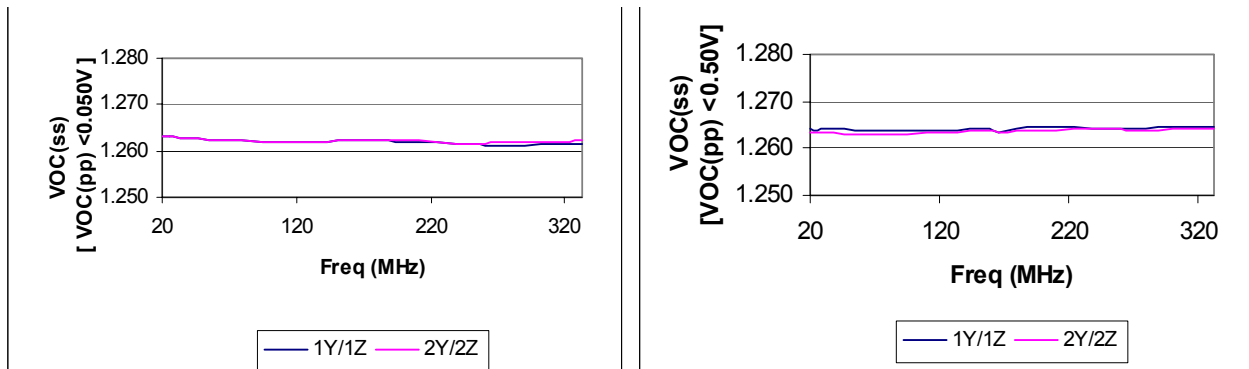

Figure 5. VOC(ss) vs. Frequency

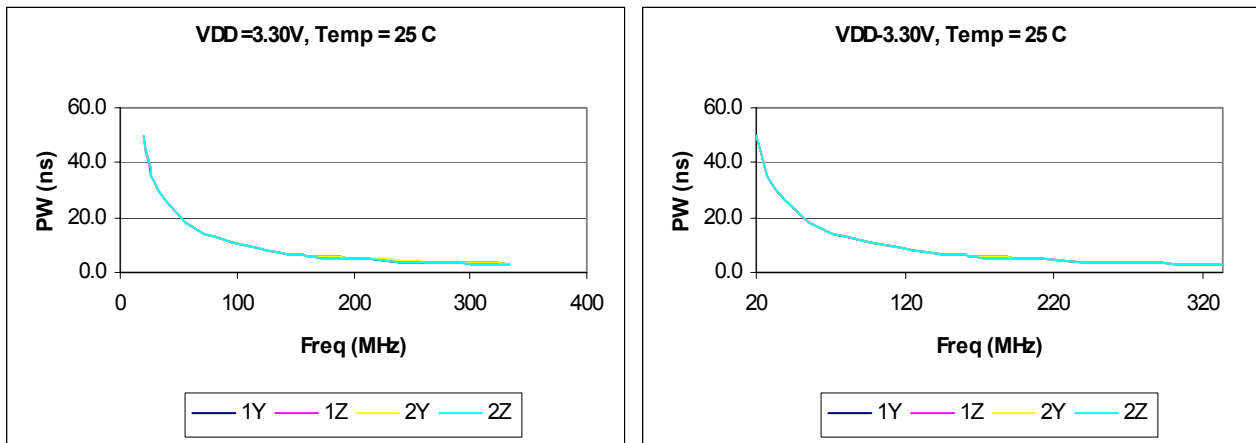

Figure 6. Pulse width vs. Frequency

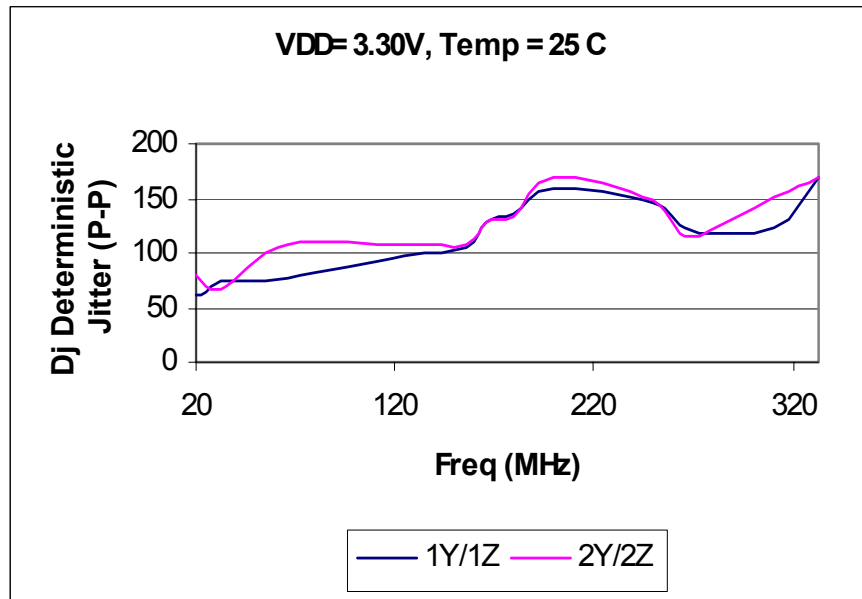

Figure 7. Deterministic Jitter (p-p) vs. Frequency

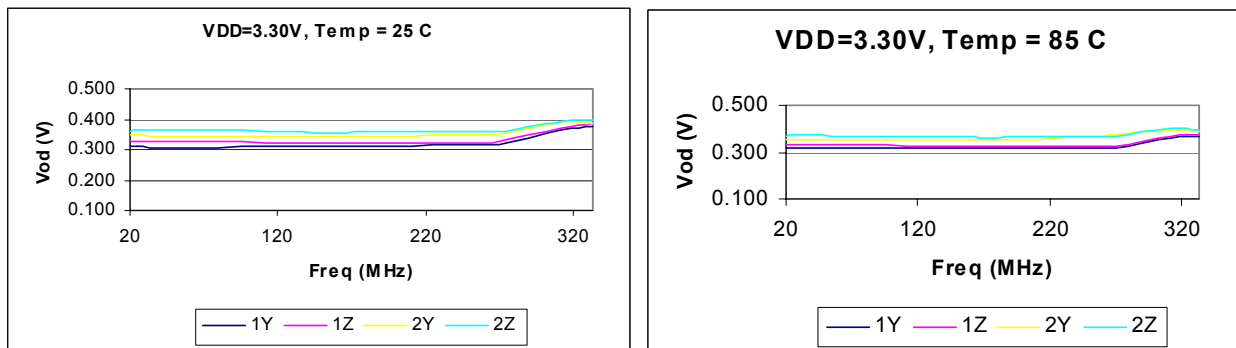

Figure 8. TPLH vs. VIC 3.3V, 50 MHz

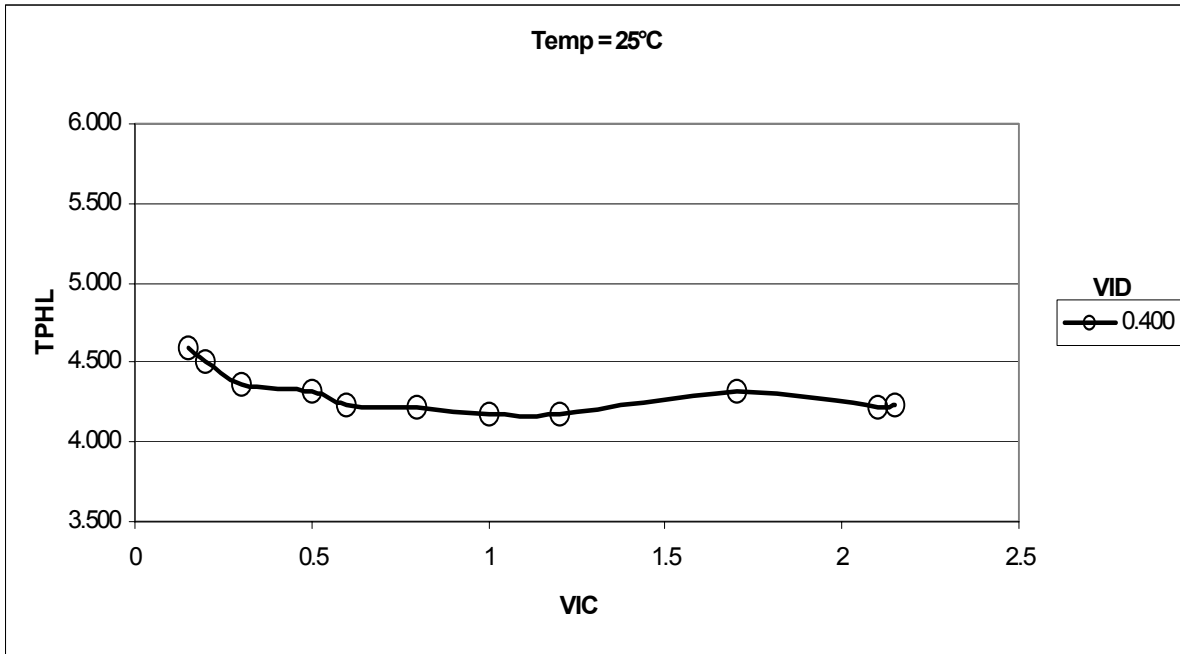

Figure 9. TPHL vs. VIC 3.3V, 50 MHz

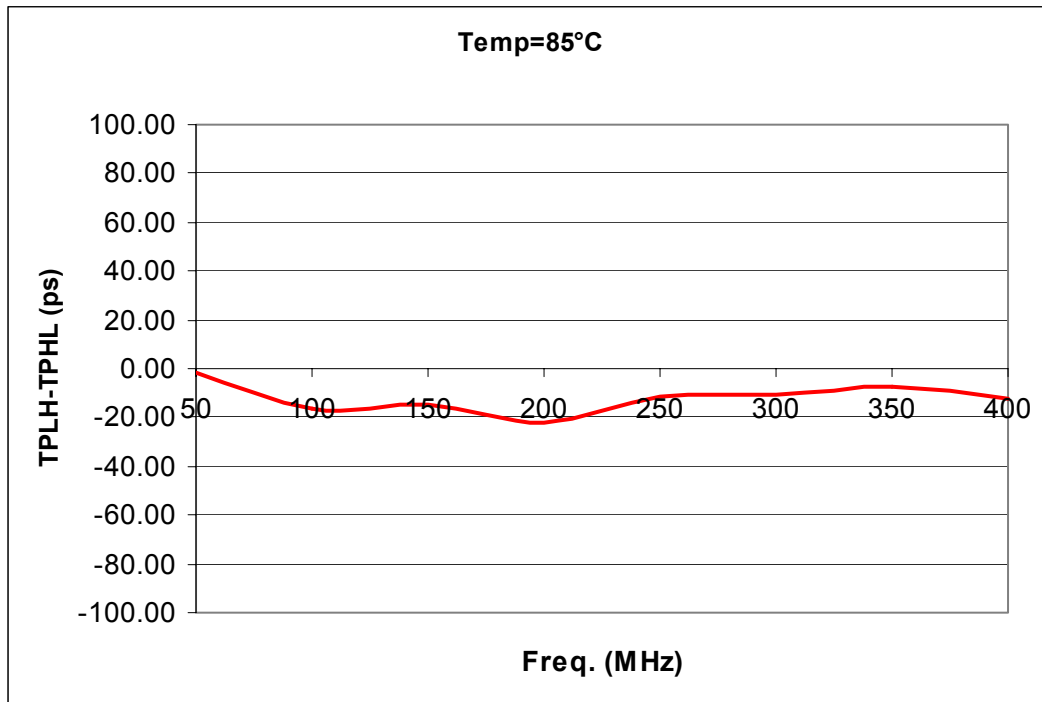

Figure 10. TPLH-TPHL vs. VIC 3.3V

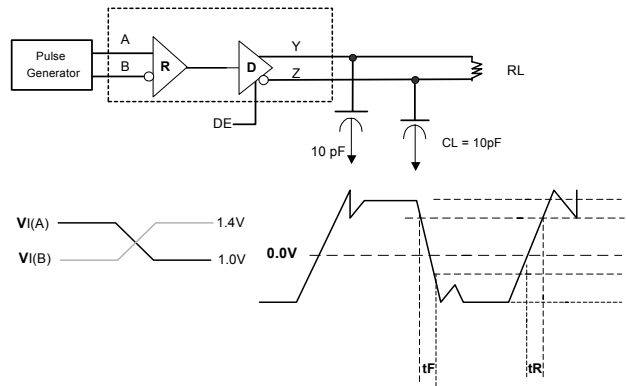

Figure 11. Test Circuit and Voltage Definitions for the Differential Output Signal[[6],[7],[8]]

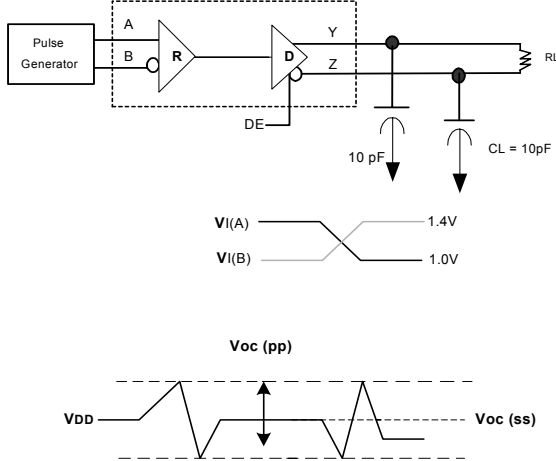

Figure 12. Test Circuit and Voltage Definitions for the Driver Common-Mode Output Voltage[[6],[7],[8],[9]]

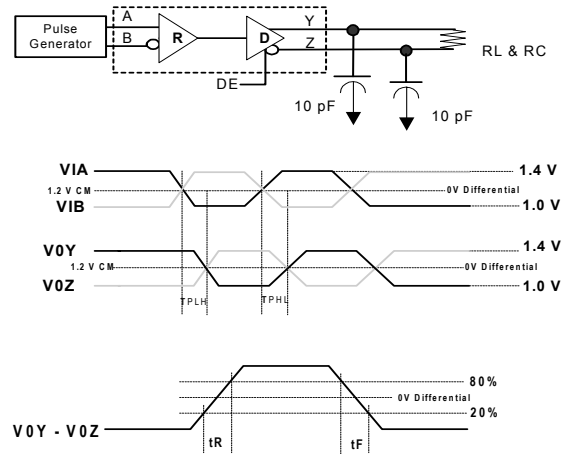

Figure 13. Differential Receiver to Driver Propagation Delay and Driver Transition Time[[6],[10],[11]]

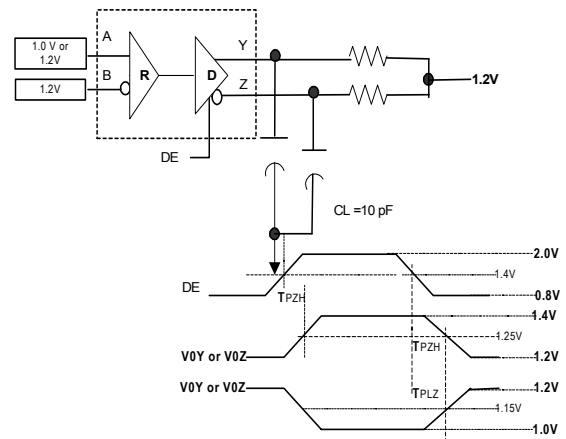
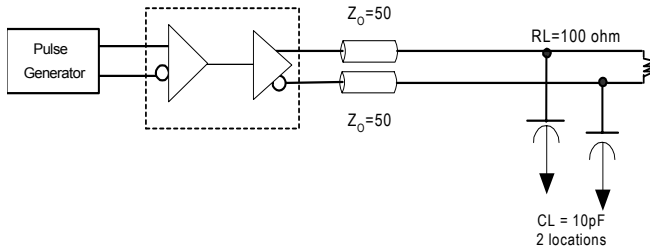
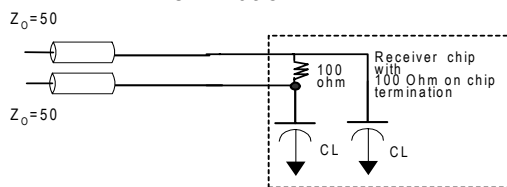
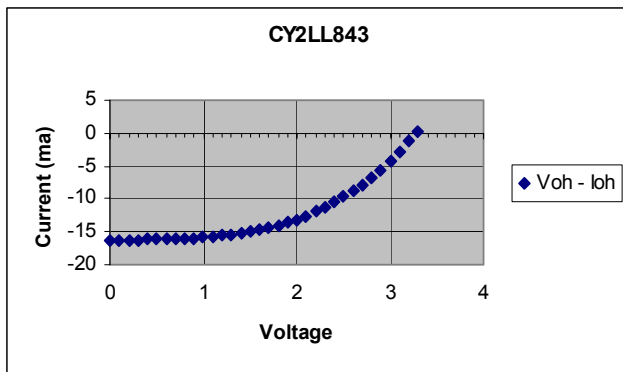
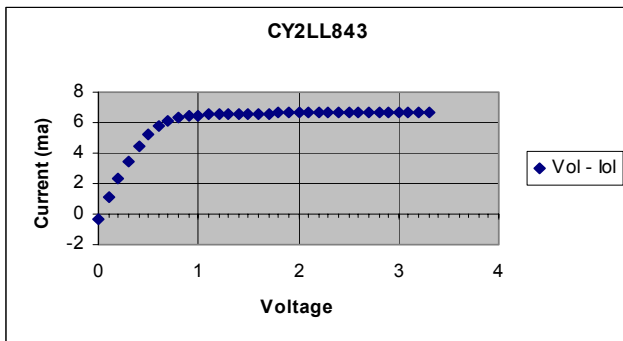

Figure 14. Test Circuit & Voltage Definitions for the Driver Common-Mode Output Voltage[[6],[10]]

Notes:

6. All input pulses are supplied by a frequency generator with the following characteristics: t_R and $t_F \leq 1$ nS; pulse rep. rate = 50 MppS; pulse width = 10 ± 0.2 nS.
7. $R_L = 50$ Ohm.
8. C_L includes instrumentation and fixture capacitance within 6 mm of the DUT.
9. VOC measurement requires equipment with a 3 dB bandwidth of at least 300 MHz.
10. $R_L = 50$ Ohm $\pm 1\%$.
11. Point to Point: $R_L = 50$ Ohm $\pm 1\%$ $C_L 3$ pF.

Application Engineering

Figure 15. Termination Scheme for 100-Ohm External Termination

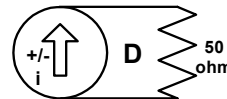
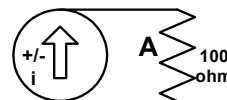
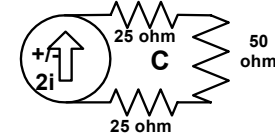
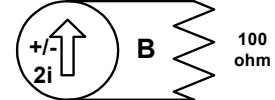
Figure 16. Termination Scheme for 100-Ohm Self-termination Interface Chip
Typical Characteristics (@VDD = 3.3V/TA = 25°C)

Figure 17. VOH vs. IOH

Figure 18. Low-level Output vs. Current
Table 8. Technical Notes on STD Drive (LL842, A and D) vs. High Drive (LL843, B and C)^{[[12]]}

	A	B	C	D	Unit
VOX	1.2	1.2	1.2	1.2	V
DC Offset	1.0	1.0	1.0	1.0	V
VOD Min.	0.25	0.5	0.25	0.125	V
VOD Max	0.45	0.9	0.45	0.225	V
T/Rise	1.4	1.4	0.6	0.6	ns
T/Fall	1.4	1.4	0.6	0.6	ns

**Standard Drive
Current drive of 1i**

**Hi Drive
Current drive of 2i**

Figure 19. Comparison Standard Drive '842 vs. High Drive '843

Note:
12. See Figure 19.



Ordering Information

Part Number	Package Type	Product Flow
CY2LL843SI	16-pin SOIC	Industrial, -40°C to 85°C
CY2LL843SIT	16-pin SOIC–Tape and Reel	Industrial, -40° to 85°C
CY2LL843ZI	16-Pin TSSOP	Industrial, -40° to 85°C
CY2LL843ZIT	16-pin TSSOP–Tape and Reel	Industrial, -40°C to 85°C
CY2LL843SC	16-pin SOIC	Commercial, 0°C to 70°C
CY2LL843SCT	16-pin SOIC–Tape and Reel	Commercial, 0°C to 70°C
CY2LL843ZC	16-pin TSSOP	Commercial, 0°C to 70°C
CY2LL843ZCT	16-pin TSSOP–Tape and Reel	Commercial, 0°C to 70°C

Package Drawings and Dimensions

16-Lead (150-Mil) Molded SOIC S16

Package Drawings and Dimensions (continued)

16-pin Thin Shrunken Small Outline Package (4.40 MM Body) Z16

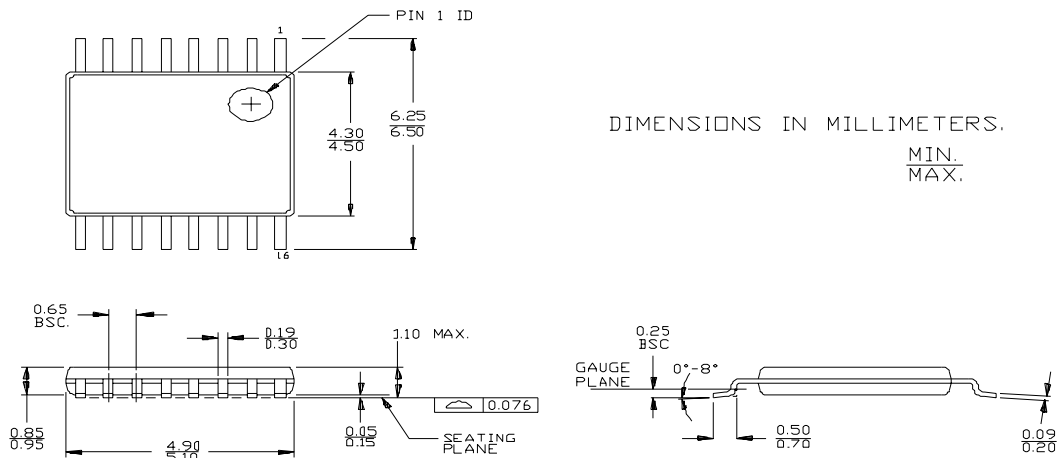

51-85091

All product and company names mentioned in this document are the trademarks of their respective holders.



Document Title: CY2LL843 High-drive Two-Channel LVDS Repeater/Mux
Document Number: 38-07066

REV.	ECN No.	Issue Date	Orig. of Change	Description of Change
**	116745	08/01/02	CTK	New Data sheet
*A	122751	12/14/02	RBI	Add power up requirements to operating conditions information
OBS	294832	See ECN	RGL	To Obsolete the DS



中发网 WWW.ZFA.CN

全球最大的PDF中文下载站



中发网
www.zfa.cn

PDF 资料下载尽在中发网