



# CY23S08

## 3.3V Zero Delay Buffer

### Features

- Zero input-output propagation delay, adjustable by capacitive load on FBK input
- Multiple configurations, see *Table 2*
- Multiple low-skew outputs
  - 45ps typical output-output skew(-1)
  - Two banks of four outputs, three-stateable by two select inputs
- 10-MHz to 133-MHz operating range
- 65ps typical cycle-cycle jitter (-1, -1H)
- Advanced 0.65μ CMOS technology
- Space-saving 16-pin 150-mil SOIC/TSSOP packages
- 3.3V operation
- Spread Aware™

### Functional Description

The CY23S08 is a 3.3V zero delay buffer designed to distribute high-speed clocks in PC, workstation, datacom, telecom, and other high-performance applications.

The part has an on-chip PLL which locks to an input clock presented on the REF pin. The PLL feedback is required to be driven into the FBK pin, and can be obtained from one of the outputs. The input-to-output propagation delay is guaranteed to be less than 350 ps, and output-to-output skew is guaranteed to be less than 250 ps.

The CY23S08 has two banks of four outputs each, which can be controlled by the Select inputs as shown in *Table 1*. If all output clocks are not required, Bank B can be three-stated. The select inputs also allow the input clock to be directly applied to the output for chip and system testing purposes.

The CY23S08 PLL enters a power-down state when there are no rising edges on the REF input. In this mode, all outputs are three-stated and the PLL is turned off, resulting in less than 50 μA of current draw. The PLL shuts down in two additional cases as shown in *Table 1*.

Multiple CY23S08 devices can accept the same input clock and distribute it in a system. In this case, the skew between the outputs of two devices is guaranteed to be less than 700 ps.

The CY23S08 is available in five different configurations, as shown in *Table 2*. The CY23S08-1 is the base part, where the output frequencies equal the reference if there is no counter in the feedback path. The CY23S08-1H is the high-drive version of the -1, and rise and fall times on this device are much faster.

The CY23S08-2 allows the user to obtain 2X and 1X frequencies on each output bank. The exact configuration and output frequencies depends on which output drives the feedback pin. The CY23S08-2H is the high-drive version of the -2, and rise and fall times on this device are much faster.

The CY23S08-3 allows the user to obtain 4X and 2X frequencies on the outputs.

The CY23S08-4 enables the user to obtain 2X clocks on all outputs. Thus, the part is extremely versatile, and can be used in a variety of applications.

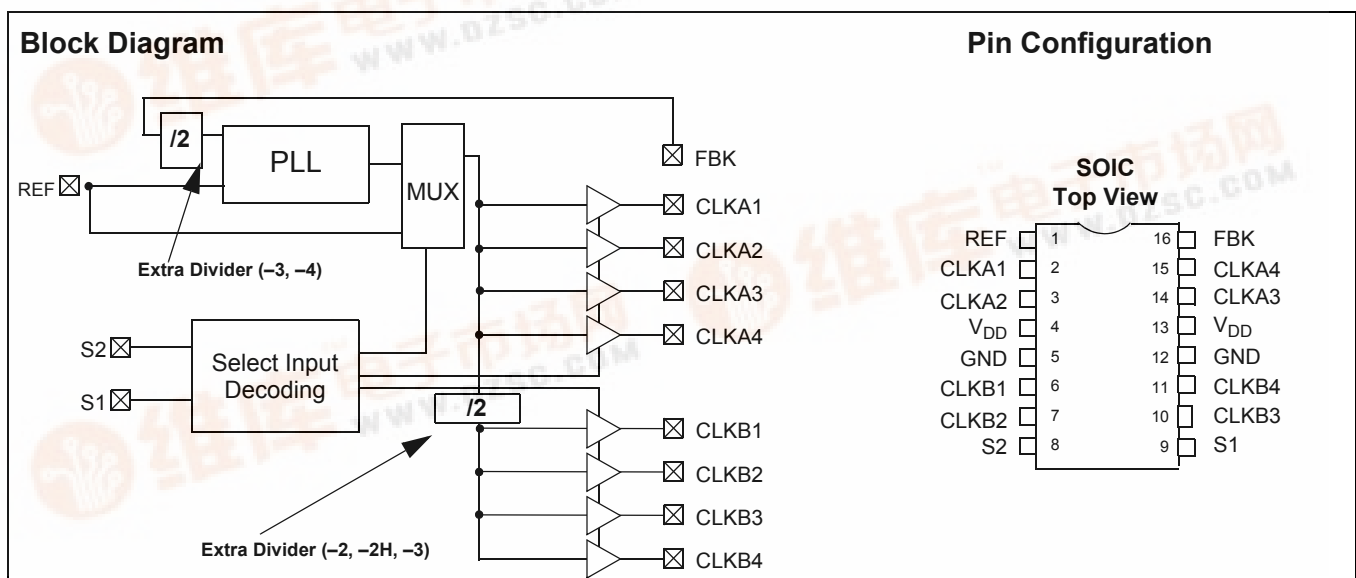

**Table 1. Select Input Decoding**

S2	S1	CLOCK A1–A4	CLOCK B1–B4	Output Source	PLL Shutdown
0	0	Three-State	Three-State	PLL	Y
0	1	Driven	Three-State	PLL	N
1	0	Driven	Driven	Reference	Y
1	1	Driven	Driven	PLL	N

**Table 2. Available CY23S08 Configurations**

Device	Feedback From	Bank A Frequency	Bank B Frequency
CY23S08–1	Bank A or Bank B	Reference	Reference
CY23S08–1H	Bank A or Bank B	Reference	Reference
CY23S08–2	Bank A	Reference	Reference/2
CY23S08–2H	Bank A	Reference	Reference/2
CY23S08–2	Bank B	2 X Reference	Reference
CY23S08–2H	Bank B	2 X Reference	Reference
CY23S08–3	Bank A	2 X Reference	Reference or Reference <sup>[1]</sup>
CY23S08–3	Bank B	4 X Reference	2 X Reference
CY23S08–4	Bank A or Bank B	2 X Reference	2 X Reference

**Pin Description**

Pin	Signal	Description
1	REF <sup>[2]</sup>	Input reference frequency, 5V tolerant input
2	CLKA1 <sup>[3]</sup>	Clock output, Bank A
3	CLKA2 <sup>[3]</sup>	Clock output, Bank A
4	V <sub>DD</sub>	3.3V supply
5	GND	Ground
6	CLKB1 <sup>[3]</sup>	Clock output, Bank B
7	CLKB2 <sup>[3]</sup>	Clock output, Bank B
8	S2 <sup>[4]</sup>	Select input, bit 2
9	S1 <sup>[4]</sup>	Select input, bit 1
10	CLKB3 <sup>[3]</sup>	Clock output, Bank B
11	CLKB4 <sup>[3]</sup>	Clock output, Bank B
12	GND	Ground
13	V <sub>DD</sub>	3.3V supply
14	CLKA3 <sup>[3]</sup>	Clock output, Bank A
15	CLKA4 <sup>[3]</sup>	Clock output, Bank A
16	FBK	PLL feedback input

**Spread Aware™**

Many systems being designed now utilize a technology called Spread Spectrum Frequency Timing Generation. Cypress has been one of the pioneers of SSFTG development, and we designed this product so as not to filter off the Spread Spectrum feature of the Reference input, assuming it exists. When a zero delay buffer is not designed to pass the SS

feature through, the result is a significant amount of tracking skew which may cause problems in systems requiring synchronization.

For more details on Spread Spectrum timing technology, please see Cypress's application note *EMI Suppression Techniques with Spread Spectrum Frequency Timing Generator (SSFTG) ICs*.

**Notes:**

1. Output phase is indeterminant (0° or 180° from input clock). If phase integrity is required, use the CY23S08–2.
2. Weak pull-down.
3. Weak pull-down on all outputs.
4. Weak pull-ups on these inputs.



**Maximum Ratings**

Supply Voltage to Ground Potential ..... -0.5V to +7.0V  
 DC Input Voltage (Except Ref).....-0.5V to  $V_{DD} + 0.5V$   
 DC Input Voltage REF.....-0.5 to 7V

Storage Temperature ..... -65°C to +150°C  
 Max. Soldering Temperature (10 sec.) ..... 260°C  
 Junction Temperature ..... 150°C  
 Static Discharge Voltage  
 (per MIL-STD-883, Method 3015) ..... >2000V

**Operating Conditions for CY23S08SC-XX Commercial Temperature Devices<sup>[5]</sup>**

Parameter	Description	Min.	Max.	Unit
$V_{DD}$	Supply Voltage	3.0	3.6	V
$T_A$	Operating Temperature (Ambient Temperature)	0	70	°C
$C_L$	Load Capacitance, below 100 MHz	—	30	pF
	Load Capacitance, from 100 MHz to 133 MHz	—	15	pF
$C_{IN}$	Input Capacitance <sup>[6]</sup>	—	7	pF

**Electrical Characteristics for CY23S08SC-XX Commercial Temperature Devices**

Parameter	Description	Test Conditions	Min.	Max	Unit
$V_{IL}$	Input LOW Voltage		—	0.8	V
$V_{IH}$	Input HIGH Voltage		2.0	—	V
$I_{IL}$	Input LOW Current	$V_{IN} = 0V$	—	50.0	μA
$I_{IH}$	Input HIGH Current	$V_{IN} = V_{DD}$	—	100.0	μA
$V_{OL}$	Output LOW Voltage <sup>[7]</sup>	$I_{OL} = 8\text{ mA} (-1, -2, -3, -4)$ $I_{OL} = 12\text{ mA} (-1H, -2H)$	—	0.4	V
$V_{OH}$	Output HIGH Voltage <sup>[7]</sup>	$I_{OH} = -8\text{ mA} (-1, -2, -3, -4)$ $I_{OH} = -12\text{ mA} (-1H, -2H)$	2.4	—	V
$I_{DD}$ (PD mode)	Power-down Supply Current	REF = 0 MHz	—	12.0	μA
$I_{DD}$	Supply Current	Unloaded outputs, 100-MHz REF, Select inputs at $V_{DD}$ or GND	—	45.0	mA
			—	70.0 (-1H, -2H)	mA
		Unloaded outputs, 66-MHz REF (-1, -2, -3, -4)	—	32.0	mA
		Unloaded outputs, 33-MHz REF (-1, -2, -3, -4)	—	18.0	mA

**Switching Characteristics for CY23S08SC-XX Commercial Temperature Devices<sup>[8]</sup>**

Parameter	Name	Test Conditions	Min.	Typ.	Max.	Unit
t1	Output Frequency	30-pF load, -1, -1H, -2, -3 devices	10	—	100	MHz
t1	Output Frequency	30-pF load, -4 devices	15	—	100	MHz
t1	Output Frequency	20-pF load, -1H device	10	—	133.3	MHz
t1	Output Frequency	15-pF load, -1, -2, -3, devices	10	—	140.0	MHz
t1	Output Frequency	15-pF load, -4 devices	15	—	140.0	MHz
	Duty Cycle <sup>[7]</sup> = $t_2 \div t_1$ (-1, -2, -3, -4, -1H, -2H)	Measured at $V_{DD}/2$ , $F_{OUT} = 66.66\text{ MHz}$ 30-pF load	40.0	50.0	60.0	%
	Duty Cycle <sup>[7]</sup> = $t_2 \div t_1$ (-1, -2, -3, -4, -1H, -2H)	Measured at $V_{DD}/2$ , $F_{OUT} < 66.66\text{ MHz}$ 15-pF load	45.0	50.0	55.0	%
t3	Rise Time <sup>[7]</sup> (-1, -2, -3, -4)	Measured between 0.8V and 2.0V, 30-pF load	—	—	2.20	ns
t3	Rise Time <sup>[7]</sup> (-1, -2, -3, -4)	Measured between 0.8V and 2.0V, 15-pF load	—	—	1.50	ns

**Notes:**

- Multiple Supplies: The voltage on any input or I/O pin cannot exceed the power pin during power-up. Power supply sequencing is NOT required.
- Applies to both Ref Clock and FBK.
- Parameter is guaranteed by design and characterization. Not 100% tested in production.
- All parameters are specified with loaded outputs.

**Switching Characteristics for CY23S08SC-XX Commercial Temperature Devices (continued)<sup>[8]</sup>**

Parameter	Name	Test Conditions	Min.	Typ.	Max.	Unit
t <sub>3</sub>	Rise Time <sup>[7]</sup> (-1H, -2H)	Measured between 0.8V and 2.0V, 30-pF load	—	—	1.50	ns
t <sub>4</sub>	Fall Time <sup>[7]</sup> (-1, -2, -3, -4)	Measured between 0.8V and 2.0V, 30-pF load	—	—	2.20	ns
t <sub>4</sub>	Fall Time <sup>[7]</sup> (-1, -2, -3, -4)	Measured between 0.8V and 2.0V, 15-pF load	—	—	1.50	ns
t <sub>4</sub>	Fall Time <sup>[7]</sup> (-1H, 2H)	Measured between 0.8V and 2.0V, 30-pF load	—	—	1.25	ns
t <sub>5</sub>	Output to Output Skew on same Bank (-1) <sup>[7]</sup>	All outputs equally loaded		45	200	ps
	Output to Output Skew on same Bank (-1H, -2, -2H, -3) <sup>[7]</sup>	All outputs equally loaded	—	105	150	ps
	Output to Output Skew on same Bank (-4) <sup>[7]</sup>	All outputs equally loaded	—	70	100	ps
	Output to Output Skew (-1H, -2H)	All outputs equally loaded	—	—	200	ps
	Output Bank A to Output Bank B Skew (-1, -2, -3)	All outputs equally loaded	—	—	300	ps
	Output Bank A to Output Bank B Skew (-4)	All outputs equally loaded	—	—	215	ps
	Output Bank A to Output Bank B Skew (-1H)	All outputs equally loaded	—	—	250	ps
t <sub>6</sub>	Delay, REF Rising Edge to FBK Rising Edge <sup>[7]</sup>	Measured at V <sub>DD</sub> /2	-250	—	+275	ps
t <sub>7</sub>	Device to Device Skew <sup>[7]</sup>	Measured at V <sub>DD</sub> /2 on the FBK pins of devices	—	—	700	ps
t <sub>8</sub>	Output Slew Rate <sup>[7]</sup>	Measured between 0.8V and 2.0V on -1H, -2H device using Test Circuit #2	1	—		V/ns
t <sub>J</sub>	Cycle to Cycle Jitter <sup>[7]</sup> (-1, -1H)	Measured at 66.67 MHz, loaded outputs, 15, 30-pF loads: 133 MHz, 15-pF load	—	65	125	ps
	Cycle to Cycle Jitter <sup>[7]</sup> (-2)	Measured at 66.67 MHz, loaded outputs, 15-pF load	—	85	300	ps
	Cycle to Cycle Jitter <sup>[7]</sup> (-2)	Measured at 66.67 MHz, loaded outputs, 30-pF load	—	—	400	ps
t <sub>J</sub>	Cycle to Cycle Jitter <sup>[7]</sup> (-3, -4)	Measured at 66.67 MHz, loaded outputs 15, 30-pF loads	—	—	200	ps
t <sub>LOCK</sub>	PLL Lock Time <sup>[7]</sup>	Stable power supply, valid clocks presented on REF and FBK pins	—	—	1.0	ms

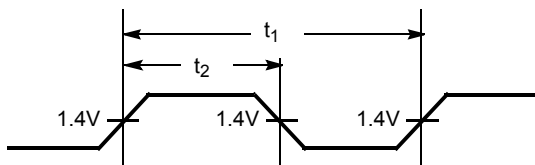
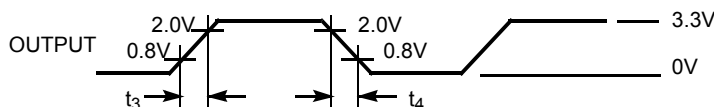
**Switching Waveforms**
**Duty Cycle Timing**

**All Outputs Rise/Fall Time**

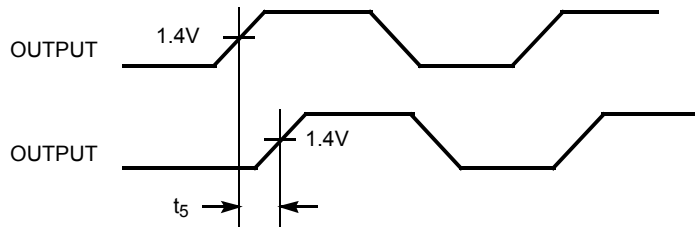
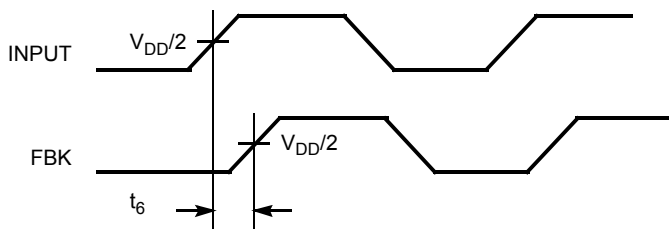
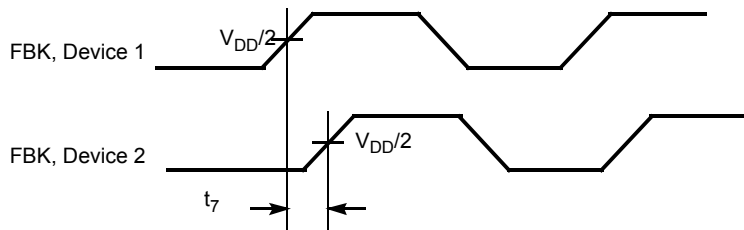
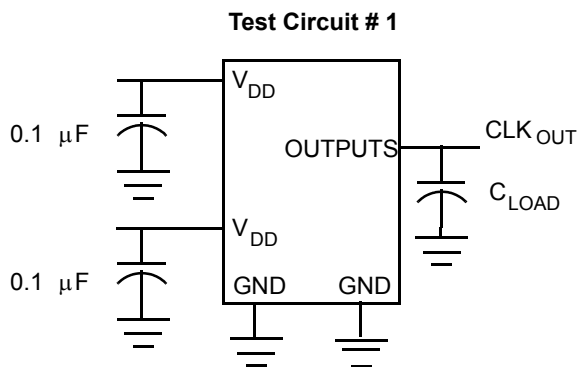
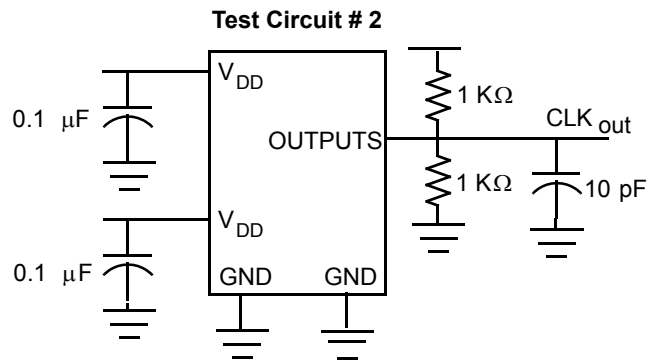
**Switching Waveforms** (continued)

**Output-Output Skew**

**Input-Output Propagation Delay**

**Device-Device Skew**

**Test Circuits**

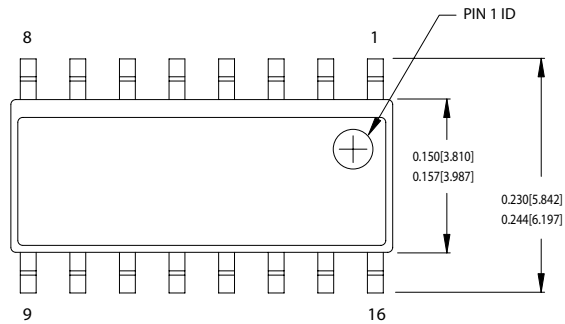
 Test Circuit for all parameters except  $t_8$ 

 Test Circuit for  $t_8$ , Output slew rate on -1H device



**Ordering Information**

<b>Ordering Code</b>	<b>Package Type</b>	<b>Operating Range</b>
CY23S08SC-1	16-pin 150-mil SOIC	Commercial
CY23S08SC-1T	16-pin 150-mil SOIC-Tape and Reel	Commercial
CY23S08SI-1	16-pin 150-mil SOIC	Industrial
CY23S08SI-1T	16-pin 150-mil SOIC-Tape and Reel	Industrial
CY23S08SC-1H	16-pin 150-mil SOIC	Commercial
CY23S08SC-1HT	16-pin 150-mil SOIC-Tape and Reel	Commercial
CY23S08SI-1H	16-pin 150-mil SOIC	Industrial
CY23S08SI-1HT	16-pin 150-mil SOIC-Tape and Reel	Industrial
CY23S08ZC-1H	16-pin 150-mil TSSOP	Commercial
CY23S08ZC-1HT	16-pin 150-mil TSSOP-Tape and Reel	Commercial
CY23S08SC-2	16-pin 150-mil SOIC	Commercial
CY23S08SC-2T	16-pin 150-mil SOIC-Tape and Reel	Commercial
CY23S08SI-2	16-pin 150-mil SOIC	Industrial
CY23S08SI-2T	16-pin 150-mil SOIC-Tape and Reel	Industrial
CY23S08SC-2H	16-pin 150-mil SOIC	Commercial
CY23S08SC-2HT	16-pin 150-mil SOIC-Tape and Reel	Commercial
CY23S08SC-3	16-pin 150-mil SOIC	Commercial
CY23S08SC-3T	16-pin 150-mil SOIC-Tape and Reel	Commercial
CY23S08SC-4	16-pin 150-mil SOIC	Commercial
CY23S08SC-4T	16-pin 150-mil SOIC-Tape and Reel	Commercial
CY23S08SI-4	16-pin 150-mil SOIC	Industrial
CY23S08SI-4T	16-pin 150-mil SOIC-Tape and Reel	Industrial
<b>Lead-free</b>		
CY23S08SXC-1	16-pin 150-mil SOIC	Commercial
CY23S08SXC-1T	16-pin 150-mil SOIC-Tape and Reel	Commercial
CY23S08SXC-2	16-pin 150-mil SOIC	Commercial
CY23S08SXC-2T	16-pin 150-mil SOIC-Tape and Reel	Commercial
CY23S08SXC-2H	16-pin 150-mil SOIC	Commercial
CY23S08SXC-2HT	16-pin 150-mil SOIC-Tape and Reel	Commercial

**Package Drawings and Dimensions**
**16-Lead (150-Mil) SOIC S16**

DIMENSIONS IN INCHES[MM] MIN. MAX.

REFERENCE JEDEC MS-012  
PACKAGE WEIGHT 0.15gms

PART #
S16.15 STANDARD PKG.
SZ16.15 LEAD FREE PKG.

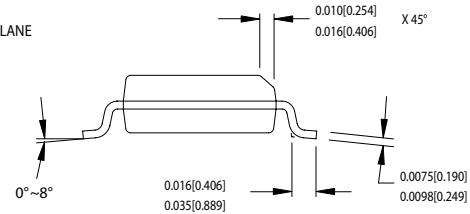
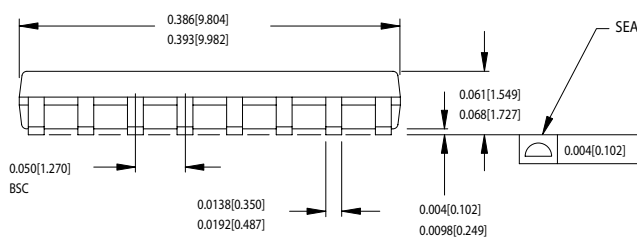

51-85068-\*B

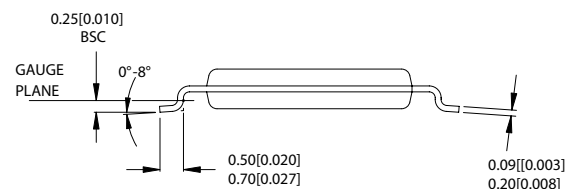
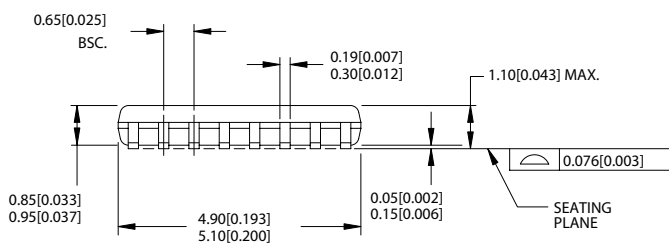
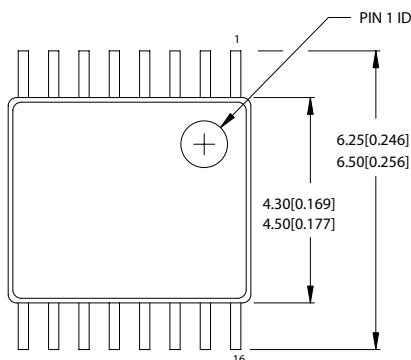
**16-Lead Thin Shrink Small Outline Package (4.40 MM Body) Z16**

51-85091-\*A

Spread Aware is a trademark of Cypress Semiconductor. All product and company names mentioned in this document are trademarks of their respective holders.



Document History Page

Document Title: CY23S08 3.3V Zero Delay Buffer				
Document Number: 38-07265				
REV.	ECN NO.	Issue Date	Orig. of Change	Description of Change
**	110530	12/02/01	SZV	Change from Spec number: 38-01107 to 38-07265
*A	122863	12/20/02	RBI	Added power-up requirements to operating conditions information.
*B	130951	11/26/03	RGL	Corrected the Switching Characteristics parameters to reflect the W152 device and new characterization.
*C	204201	See ECN	RGL	Corrected the Block Diagram
*D	231100	See ECN	RGL	Fixed Typo in table 2.
*E	378878	See ECN	RGL	Added Industrial Temp and Lead Free Devices Added typical char data Removed "Preliminary"
*F	391564	See ECN	RGL	Changed output-to-output skew typical value from 90ps to 45ps Added cycle-to-cycle jitter (-2) typical value of 85ps