



# AP1705/6/7

## Processor Supervisory Circuits

### ■ Features

- Power-on reset generator with fixed delay time of 200ms (AP1705/6/7)
- Manual reset input (AP1705/7)
- Reset output available in active-Low (AP1705/6/7), active-high (AP1706/7)
- Supply voltage supervision range 2.5V, 3V, 3.3V, 5V
- Watchdog timer (AP1705/6/7)
- Supply current of 25µA (Typ.)
- SOT23-5, SOT23-6, TSOT23-5 and TSOT23-6
- **Pb-Free** Package
- Temperature range: -40°C to 85°C

### ■ Applications

- Applications Using DSPs, Microcontrollers, or Microprocessors
- Industrial Equipment
- Programmable Controls
- Automotive Systems
- Portable/Battery-Powered Equipment
- Intelligent Instruments
- Wireless Communications Systems
- Notebook/Desktop Computers

### ■ Ordering Information

AP170X X X		
Part No.	Voltage	Package
5: AP1705	A: 4.63	W5:SOT23-5
6: AP1706	B: 4.38	W6:SOT23-6
7: AP1707	C: 4.00	TW5:TSOT23-5
	D: 3.08	TW6:TSOT23-6
	E: 2.93	
	F: 2.63	
	G: 2.25	

### ■ General Description

The AP1705/6/7 family of supervisors provides circuit initialization and timing supervision, primarily for DSP and processor-based systems.

During power-on,  $\overline{\text{RESET}}$  is asserted when supply voltage  $V_{CC}$  becomes higher than 1.1V. Thereafter, the supply voltage supervisor monitors  $V_{CC}$  and keeps

$\overline{\text{RESET}}$  active as long as  $V_{CC}$  remains below the threshold voltage  $V_{IT-}$ . An internal timer delays the return of the output to the inactive state (high) to ensure proper system reset. The delay time  $t_d$ , starts after  $V_{CC}$  has risen above the threshold voltage  $V_{IT-}$ . When the supply voltage drops below the threshold voltage  $V_{IT-}$ , the output becomes active (low) again. No external components are required. All the devices of this family have a fixed-sense threshold voltage  $V_{IT-}$ , set by an internal voltage divider.

The AP1705/7 devices incorporate a manual reset input,  $\overline{\text{MR}}$ . A low level at  $\overline{\text{MR}}$  causes  $\overline{\text{RESET}}$  to become active. The AP1706/7 devices include a high-level output RESET. AP1705/6/7 have a watchdog timer that is periodically triggered by a positive or negative transition at WDI. When the supervising system fails to retrigger the watchdog circuit within the time-out interval,  $t_{\text{tout}}$ ,  $\overline{\text{RESET}}$  becomes active for the time period  $t_d$ . This event also reinitializes the watchdog timer. Leaving WDI unconnected disables the watchdog.

In applications where the input to the WDI pin may be active (transitioning high and low) when the AP1705/6/7 asserting  $\overline{\text{RESET}}$ , the AP1705/6/7 does not return to a non-reset state when the input voltage is above  $V_t$ . If the application requires that input to WDI is active when  $\overline{\text{RESET}}$  is asserted, WDI must be decoupled from the active signal. This can be accomplished by using an N-channel FET in series with the WDI pin, with the gate of the FET connected to the RESET output as shown in Figure 1.

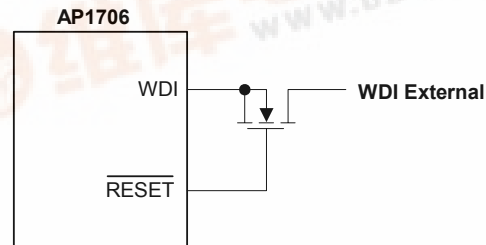
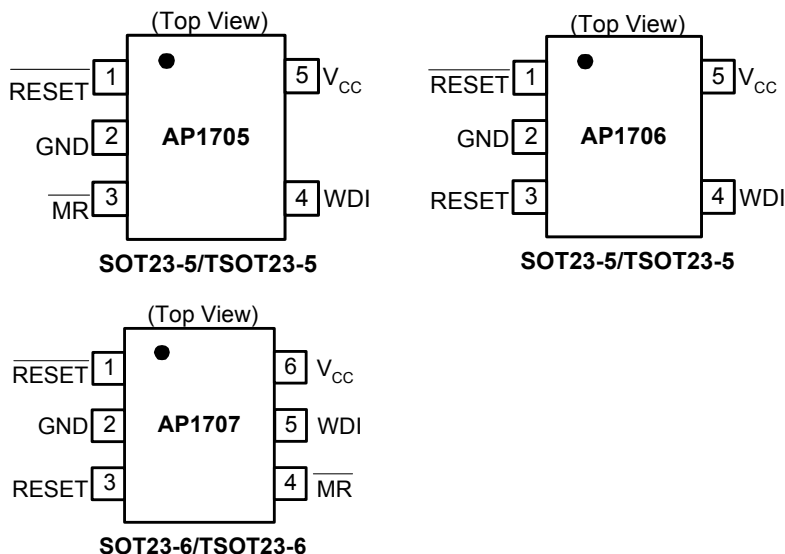

Figure 1.

The product spectrum is designed for supply voltage of 2.5V, 3V, 3.3V and 5V. The circuits are available in a SOT23-5L, SOT23-6L, and TSOT23-5L, TSOT23-6L packages. The AP1705/6/7 devices are characterized for operation over a temperature range of -40°C to 85°C.

## Processor Supervisory Circuits

### Pin Assignments



### Pin Descriptions

Name	Description
GND	Ground
RESET (RESET)	Reset output pin
V <sub>CC</sub>	Operating voltage input
WDI	Watchdog input
MR	Manual reset

### Absolute Maximum Ratings

(Over operating free-air temperature range, unless otherwise noted)\*

Symbol	Parameter	Rating	Unit	
V <sub>CC</sub>	Supply Voltage (see note 1)	6.5	V	
	RESET, $\overline{\text{RESET}}$ , $\overline{\text{MR}}$ , WDI (see note 1)	-0.3 to (V <sub>CC</sub> +0.3)	V	
I <sub>OL</sub>	Maximum Low Output Current	5	mA	
I <sub>OH</sub>	Maximum High Output Current	-5	mA	
I <sub>IK</sub>	Input Clamp Current Range (V <sub>I</sub> < 0 or V <sub>I</sub> > V <sub>CC</sub> )	±10	mA	
I <sub>OK</sub>	Output Clamp Current Range (V <sub>O</sub> < 0 or V <sub>O</sub> > V <sub>CC</sub> )	±10	mA	
P <sub>D</sub>	Continuous Total Power Dissipation	Operating Factor Above T <sub>A</sub> = 25°C	3.5	mW/°C
		T <sub>A</sub> ≤ 25°C Power Rating	437	mW
		T <sub>A</sub> = 70°C Power Rating	280	mW
		T <sub>A</sub> = 85°C Power Rating	227	mW
T <sub>A</sub>	Operating Free-air Temperature Range	-40 to 85	°C	
T <sub>STG</sub>	Storage Temperature Range	-65 to 150	°C	
T	Soldering Temperature	260	°C	

\* Stresses beyond those listed under "absolute maximum ratings" may cause permanent damage to the device. These are stress ratings only, and functional operation of the device at these or any other conditions beyond those indicated under "recommended operating conditions" is not implied. Exposure to absolute-maximum-rated conditions for extended periods may affect device reliability.

**Note 1:** All voltage values are with respect to GND.



## Processor Supervisory Circuits

### ■ Recommended Operating Conditions

Symbol	Parameter	Min.	Max.	Unit
$V_{CC}$	Supply Voltage	1.1	6	V
$V_{IN}$	Input Voltage	0	$(V_{CC}+0.3)$	V
$V_{IH}$	High-level Input Voltage at $\overline{MR}$ and WDI	$0.8 \times V_{CC}$	-	V
$V_{IL}$	Low-level Voltage	-	$0.2 \times V_{CC}$	V
$\Delta t/\Delta V$	Input Transition Rise and Fall Rate at $\overline{MR}$ or WDI	-	100	ns/V
$T_A$	Operating Free-air Temperature Range	-40	85	$^{\circ}C$
$T_r$	Vcc Rising Time ( $V_{CC} = 0 \sim V_T$ )		1	$\mu s$

### ■ Electrical Characteristics

(Over recommended operating free-air temperature range, unless otherwise noted)

Sym.	Parameter		Test Conditions	Min.	Typ.	Max.	Unit	
$V_{OH}$	High-level Output Voltage	$\overline{RESET}$	AP1705/6/7-25	$V_{CC}=V_{IT}+0.2V$ $I_{OH}=-20\mu A$	$0.8 \times V_{CC}$	-	-	V
			AP1705/6/7-30	$V_{CC}=V_{IT}+0.2V$				
			AP1705/6/7-33	$I_{OH}=-30\mu A$				
		AP1705/6/7-50	$V_{CC}=V_{IT}+0.2V$ $I_{OH}=-120\mu A$	$V_{CC}-1.5V$	-	-	V	
		$\overline{RESET}$	AP1706/7-25	$V_{CC} \geq 1.8V$ , $I_{OH} = -100\mu A$	$0.8 \times V_{CC}$	-	-	V
			AP1706/7-30	$V_{CC} \geq 1.8V$ , $I_{OH} = -150\mu A$				
AP1706/7-33								
$V_{OL}$	Low-level Output Voltage	$\overline{RESET}$	AP1706/7-25	$V_{CC}=V_{IT}+0.2V$ $I_{OL}=1mA$	-	-	0.4	V
			AP1706/7-30	$V_{CC}=V_{IT}+0.2V$				
			AP1706/7-33	$I_{OL}=1.2mA$				
			AP1706/7-50	$V_{CC}=V_{IT}+0.2V$ $I_{OL}=3mA$				
		$\overline{RESET}$	AP1705/6/7-25	$V_{CC}=V_{IT}-0.2V$ $I_{OL}=1mA$	-	-	0.4	V
			AP1705/6/7-30	$V_{CC}=V_{IT}-0.2V$				
			AP1705/6/7-33	$I_{OL}=1.2mA$				
			AP1705/6/7-50	$V_{CC}=V_{IT}-0.2V$ $I_{OL}=3mA$				
$V_{RESET}$	Power-up Reset Voltage (see Note 2)		$V_{CC} \geq 1.1V$ , $I_{OL}=20\mu A$	-	-	0.4	V	

**Note 2:** The lowest supply voltage at which  $\overline{RESET}$  becomes active.  $T_r$ ,  $V_{CC} \geq 15\mu s/V$



## Processor Supervisory Circuits

### ■ Electrical Characteristics

(Over recommended operating free-air temperature range, unless otherwise noted)

Sym.	Parameter		Test Conditions	Min.	Typ.	Max.	Unit	
V <sub>IT</sub>	Negative-going Input Threshold Voltage (see Note 3)	AP1705/6/7-25	T <sub>A</sub> = 0°C-85°C	2.21	2.25	2.30	V	
		AP1705/6/7-30		2.59	2.63	2.69		
		AP1705/6/7-33		2.88	2.93	3.00		
		AP1705/6/7-35		3.00	3.08	3.15		
		AP1705/6/7-43		3.93	4.00	4.08		
		AP1705/6/7-45		4.31	4.38	4.46		
		AP1705/6/7-50		4.56	4.63	4.71		
		AP1705/6/7-25	T <sub>A</sub> = -40°C-85°C	2.20	2.25	2.30	V	
		AP1705/6/7-30		2.57	2.63	2.69		
		AP1705/6/7-33		2.86	2.93	3.00		
		AP1705/6/7-35		3.00	3.08	3.15		
		AP1705/6/7-43		3.92	4.00	4.08		
		AP1705/6/7-45		4.30	4.38	4.46		
		AP1705/6/7-50		4.55	4.63	4.71		
V <sub>hys</sub>	Hysteresis at V <sub>CC</sub> Input	AP1705/6/7-25		-	50	-	mV	
		AP1705/6/7-30			-	50		-
		AP1705/6/7-33				-		50
		AP1705/6/7-35				-	50	-
		AP1705/6/7-43				-	50	-
		AP1705/6/7-45				-	50	-
AP1705/6/7-50		-	50			-		
I <sub>IH(AV)</sub>		Average High-level Input Current	WDI	WDI=V <sub>CC</sub> , Time average (dc=88%)		-	120	-
I <sub>IL(AV)</sub>				Average Low-level Input Current	WDI=0.3V, V <sub>CC</sub> =5.5V time average (dc=12%)	-	-15	-
I <sub>IH</sub>	High-level Input Current	WDI	WDI=V <sub>CC</sub>	-	140	190	μA	
		MR	MR = V <sub>CC</sub> × 0.7, V <sub>CC</sub> =5.5V	-	-40	-60		
I <sub>IL</sub>	Low-level Input Current	WDI	WDI=0.3V, V <sub>CC</sub> =5.5V	-	140	190	μA	
		MR	MR = 0.3V, V <sub>CC</sub> =5.5V	-	-110	-160		
I <sub>OS</sub>	Output Short-circuit Current (see note 4)	RESET	AP1705/6/7-25	V <sub>CC</sub> =V <sub>IT,mas</sub> +0.2V, V <sub>O</sub> =0V			μA	
			AP1705/6/7-30					
			AP1705/6/7-33					
			AP1705/6/7-50					
I <sub>CC</sub>	Supply Current	WDI and MR Unconnected, Outputs unconnected	V <sub>CC</sub> = V <sub>IT</sub> +1.0V	-	25	35	μA	
	Internal Pull-up Resistor at MR			-	60	-	kΩ	
TC	V <sub>OUT</sub> Temperature Coefficient				50	-	ppm/°C	
C <sub>i</sub>	Input Capacitance at MR, WDI		V <sub>I</sub> =0V to 5.5V	-	5	-	pF	

**Note 3:** To ensure best stability of the threshold voltage, a bypass capacitor (ceramic, 0.1μF) should be placed near the supply terminals.

**Note 4:** The RESET short-circuit current is the maximum pull-up current when RESET is driven low by a P bidirectional reset pin.

## Processor Supervisory Circuits

### ■ Timing requirements (at $R_L=1m\Omega$ , $C_L=50pF$ , $T_A=25^\circ C$ )

Sym.	Parameter	Test Conditions	Min.	Typ.	Max.	Unit	
$t_w$	Pulse Width	at $V_{CC}$	$V_{CC}=V_{IT-}+0.2V$ , $V_{CC}=V_{IT-}-0.2V$	3	-	-	$\mu s$
		at $\overline{MR}$	$V_{CC}\geq V_{IT-}+0.2V$ , $V_{IL}=0.3\times V_{CC}$ , $V_{IH}=0.7\times V_{CC}$	0.5	-	-	$\mu s$
		at $\overline{WDI}$	$V_{CC}\geq V_{IT-}+0.2V$ , $V_{IL}=0.3\times V_{CC}$ , $V_{IH}=0.7\times V_{CC}$	50	-	-	ns

### ■ Switching Characteristics (at $R_L=1m\Omega$ , $C_L=50pF$ , $T_A=25^\circ C$ )

Sym.	Parameter	Test Conditions	Min.	Typ.	Max.	Unit
$t_{out}$	Watchdog Time Out	AP1705/6/7 $V_{CC}\geq V_{IT-}+0.2V$ , See timing diagram	0.9	1.6	2.5	s
$t_d$	Delay Time	AP1705/6/7 $V_{CC}\geq V_{IT-}+0.2V$ , See timing diagram	120	200	300	ms
$t_{PHL}$	Propagation (Delay) Time, High-to-low-level Output	$\overline{MR}$ to $\overline{RESET}$ delay (AP1705/7)	-	-	0.1	$\mu s$
		$V_{CC}$ to $\overline{RESET}$ delay	-	-	25	$\mu s$
$t_{PLH}$	Propagation (Delay) Time, Low-to-high-level Output	$\overline{MR}$ to $\overline{RESET}$ delay (AP1706/7)	-	-	0.1	$\mu s$
		$V_{CC}$ to $\overline{RESET}$ delay (AP1706/7)	-	-	25	$\mu s$

### ■ Application Circuit

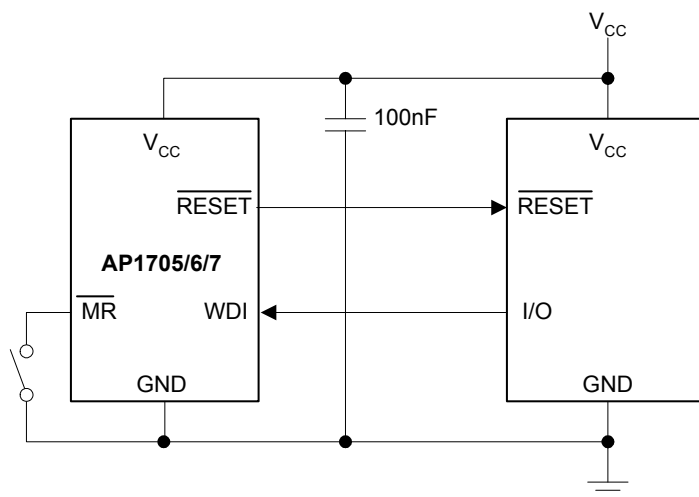

## Processor Supervisory Circuits

### ■ Function/Truth Table

Inputs		Outputs	
$\overline{MR}^*$	$V_{CC} > V_{IT}$	$\overline{RESET}$	$RESET^{**}$
L	0	L	H
L	1	L	H
H	0	L	H
H	1	H	L

\* AP1705/7

\*\* AP1706/7

### ■ Functional Block Diagram

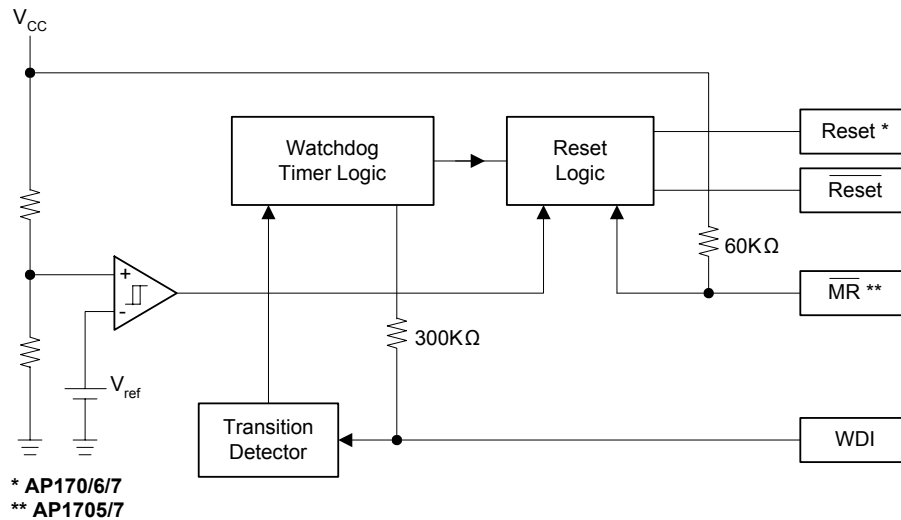

### ■ Timing Diagram

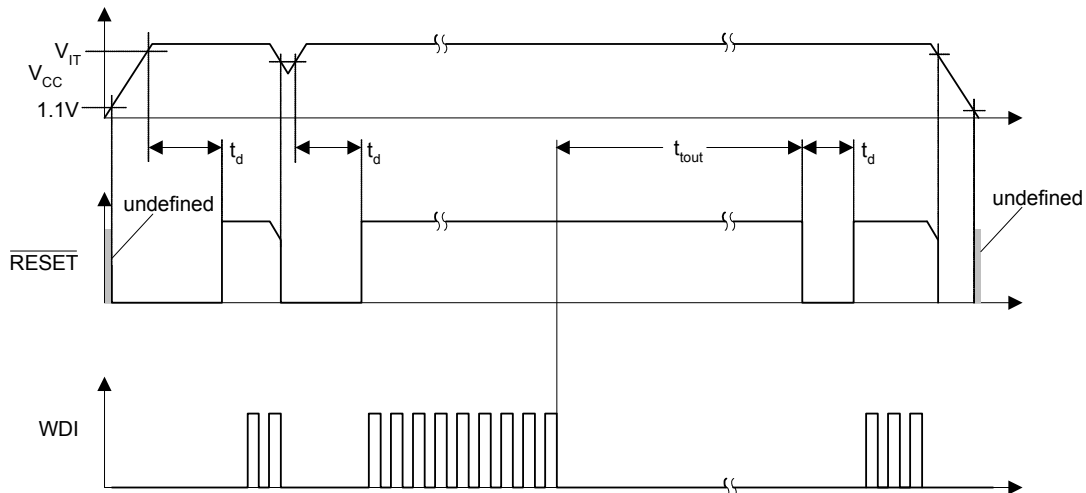

## Processor Supervisory Circuits

### ■ Typical Characteristics

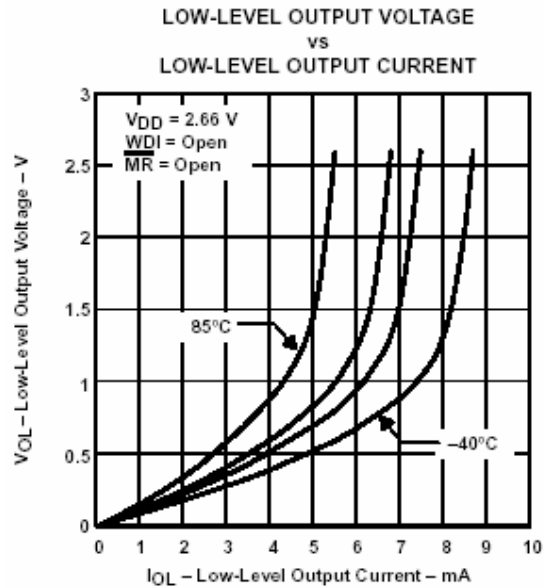
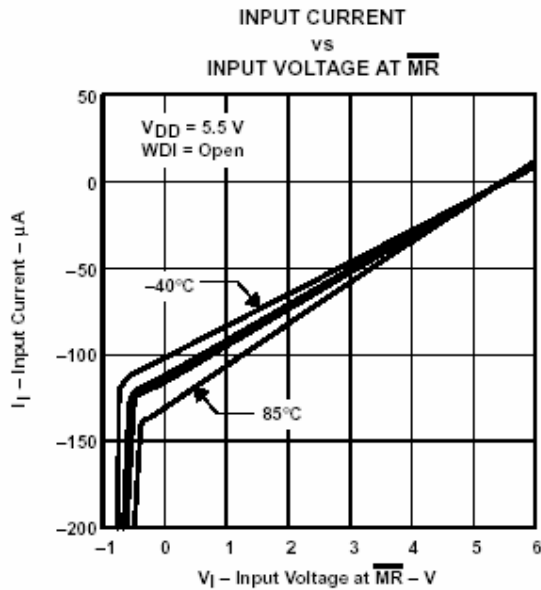
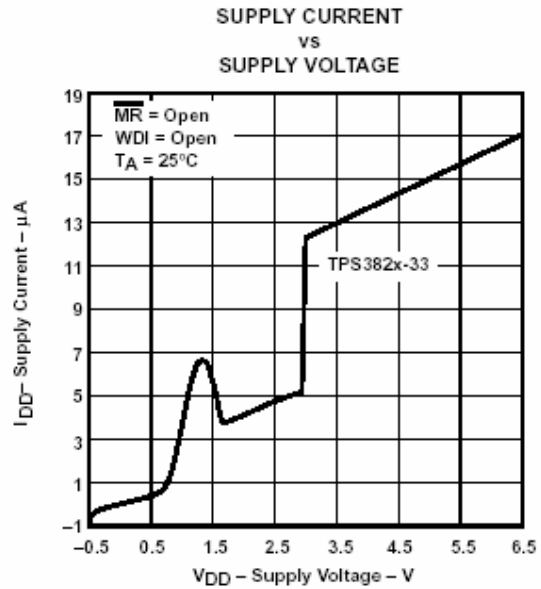
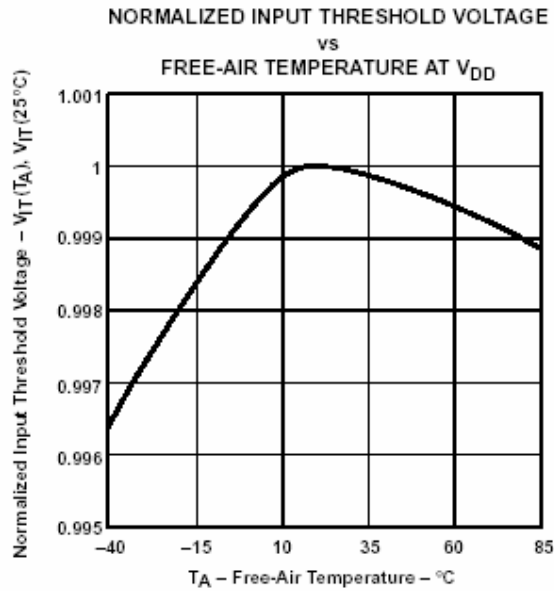

## Processor Supervisory Circuits

### ■ Typical Characteristics (Continued)

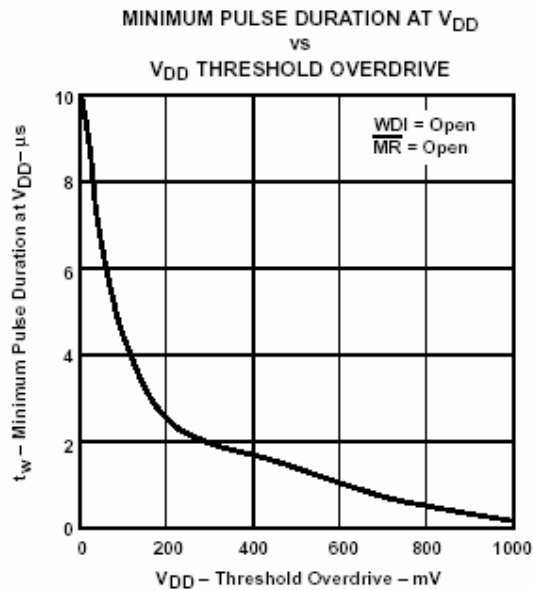
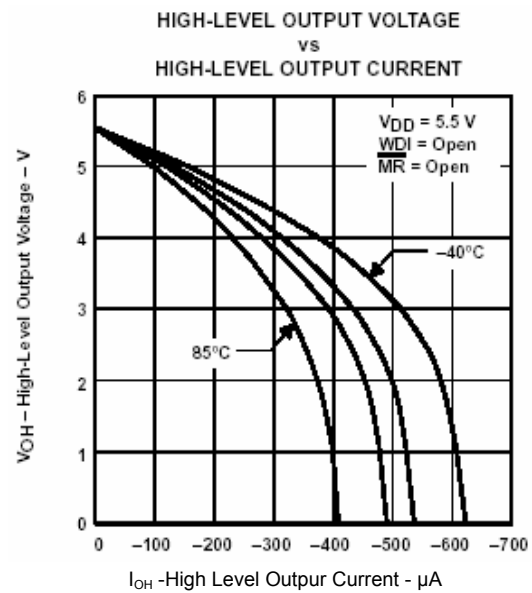
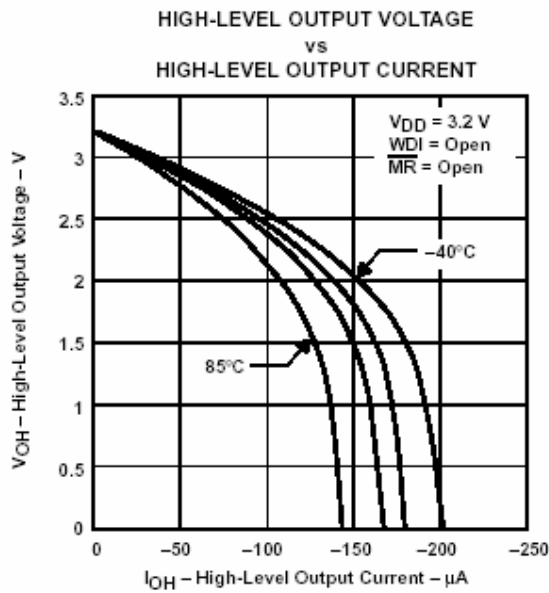



## Processor Supervisory Circuits

### ■ Marking Information

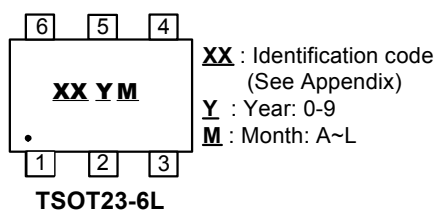
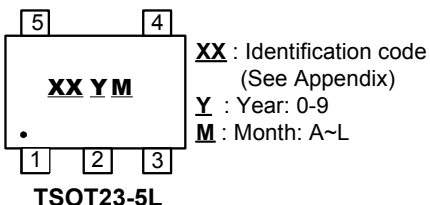
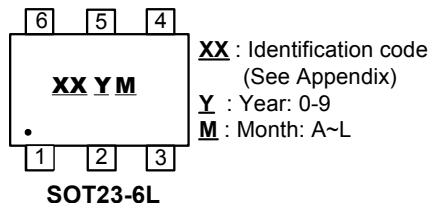
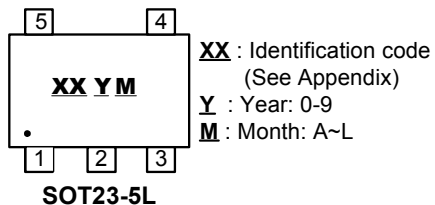

### Appendix

Package Type	Part Number	Identification Code
SOT23-5,TSOPT23-5	AP1705A	WA
SOT23-5,TSOPT23-5	AP1705B	WB
SOT23-5,TSOPT23-5	AP1705C	WC
SOT23-5,TSOPT23-5	AP1705D	WD
SOT23-5,TSOPT23-5	AP1705E	WE
SOT23-5,TSOPT23-5	AP1705F	WF
SOT23-5,TSOPT23-5	AP1705G	WG
SOT23-5,TSOPT23-5	AP1706A	WH
SOT23-5,TSOPT23-5	AP1706B	WI
SOT23-5,TSOPT23-5	AP1706C	WJ
SOT23-5,TSOPT23-5	AP1706D	WK
SOT23-5,TSOPT23-5	AP1706E	WL
SOT23-5,TSOPT23-5	AP1706F	WM
SOT23-5,TSOPT23-5	AP1706G	WN
SOT23-6,TSOPT23-6	AP1707A	WO
SOT23-6,TSOPT23-6	AP1707B	WP
SOT23-6,TSOPT23-6	AP1707C	WQ
SOT23-6,TSOPT23-6	AP1707D	WR
SOT23-6,TSOPT23-6	AP1707E	WS
SOT23-6,TSOPT23-6	AP1707F	WT
SOT23-6,TSOPT23-6	AP1707G	WU

### ■ Package Information

(1) Package Type: SOT23-5L

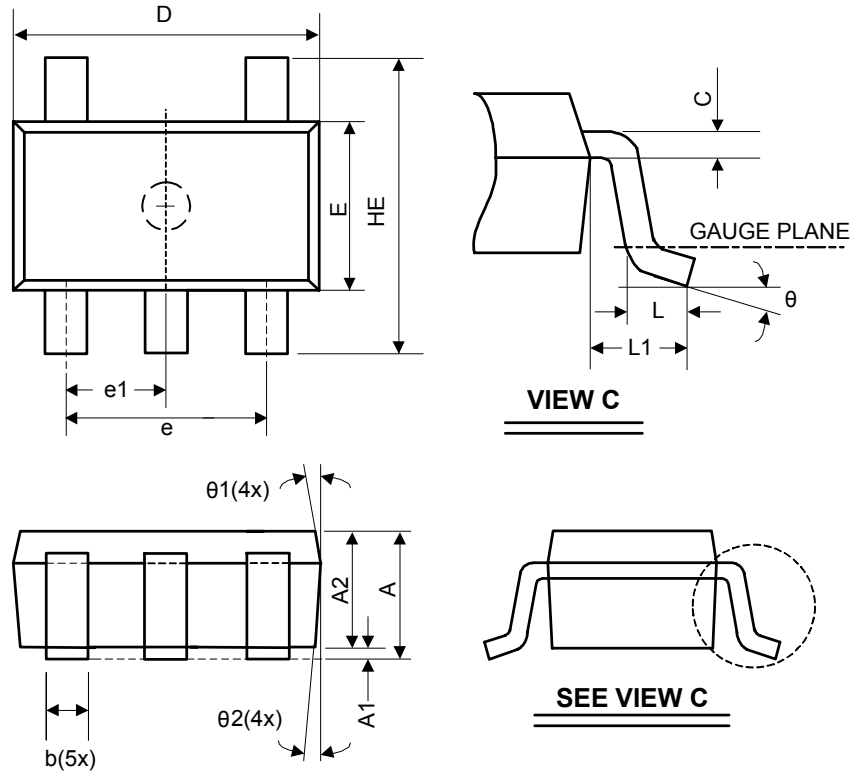

Symbol	Dimensions In Millimeters			Dimensions In Inches		
	Min.	Nom.	Max.	Min.	Nom.	Max.
A	1.05	-	1.35	0.041	-	0.053
A1	0.05	-	0.15	0.002	-	0.006
A2	1.00	1.10	1.20	0.039	0.043	0.047
b	0.25	-	0.50	0.010	-	0.020
C	0.08	-	0.20	0.003	-	0.008
D	2.70	2.90	3.00	0.106	0.114	0.118
E	1.50	1.60	1.70	0.059	0.063	0.067
HE	2.60	2.80	3.00	0.102	0.110	0.118
L	0.30	-	0.60	0.012	-	0.024
L1	0.50	0.60	0.70	0.020	0.024	0.028
e	1.80	1.90	2.00	0.071	0.075	0.079
e1	0.85	0.95	1.05	0.033	0.037	0.041
θ	0°	5°	10°	0°	5°	10°
θ1	3°	5°	7°	3°	5°	7°
θ2	6°	8°	10°	6°	8°	10°

### ■ Package Information (Continued)

(2) Package Type: SOT23-6L

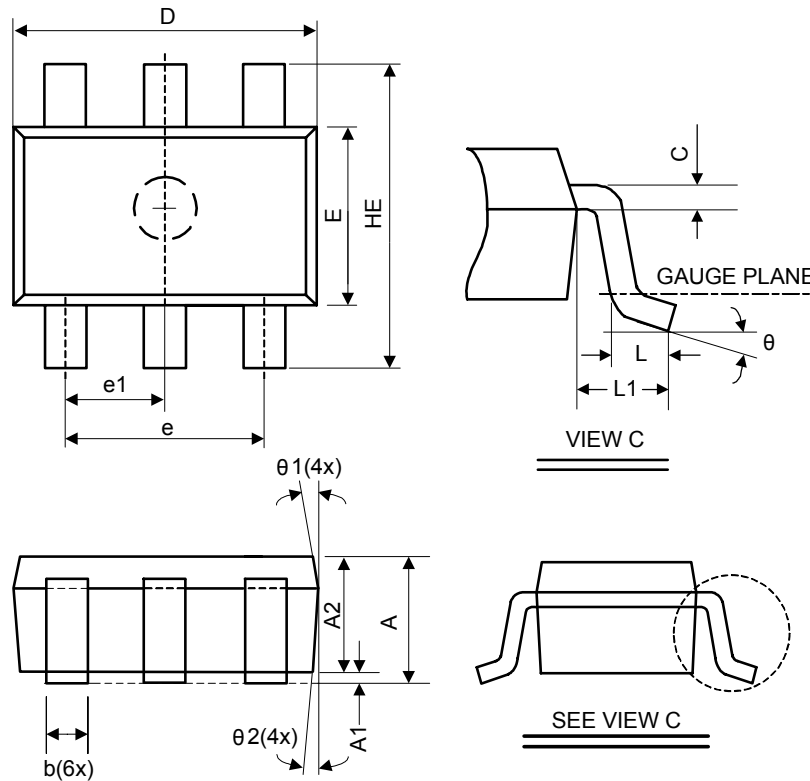

Symbol	Dimensions In Millimeters			Dimensions In Inches		
	Min.	Nom.	Max.	Min.	Nom.	Max.
A	1.05	-	1.35	0.041	-	0.053
A1	0.05	-	0.15	0.002	-	0.006
A2	1.00	1.10	1.20	0.039	0.043	0.047
b	0.25	-	0.50	0.010	-	0.020
C	0.08	-	0.20	0.003	-	0.008
D	2.70	2.90	3.00	0.106	0.114	0.118
E	1.50	1.60	1.70	0.059	0.063	0.067
HE	2.60	2.80	3.00	0.102	0.110	0.118
L	0.30	-	0.60	0.012	-	0.024
L1	0.50	0.60	0.70	0.020	0.024	0.028
e	1.80	1.90	2.00	0.071	0.075	0.079
e1	0.85	0.95	1.05	0.033	0.037	0.041
theta	0°	5°	10°	0°	5°	10°
theta1	3°	5°	7°	3°	5°	7°
theta2	6°	8°	10°	6°	8°	10°

### ■ Package Information (Continued)

(3) Package Type: TSOT23-5L

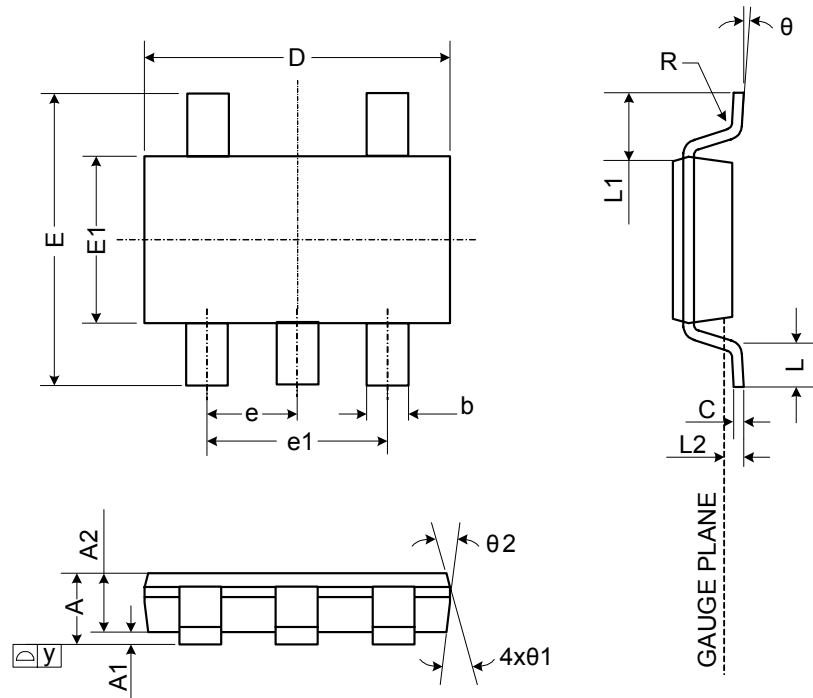

Symbol	Dimensions In Millimeters			Dimensions In Inches		
	Min.	Nom.	Max.	Min.	Nom.	Max.
A	0.75	-	0.90	0.030	-	0.035
A1	0.00	-	0.10	0.000	-	0.004
A2	0.70	0.75	0.80	0.028	0.030	0.031
b	0.35	-	0.51	0.014	-	0.020
C	0.10	-	0.25	0.004	-	0.010
D	2.80	2.90	3.00	0.110	0.114	0.118
E	2.60	2.80	3.00	0.102	0.110	0.118
E1	1.50	1.60	1.70	0.059	0.063	0.067
e	0.95 BSC.			0.037		
e1	1.90 BSC.			0.075		
L	0.37	-	-	0.015	-	-
L1	0.60 REF.			0.024		
L2	0.25 BSC.			0.010		
y	-	-	0.10	-	-	0.004
R	0.10	-	-	0.004	-	-
theta	0°	-	8°	0°	-	8°
theta1	7° NOM.			7° NOM.		
theta2	5° NOM.			5° NOM.		

### ■ Package Information (Continued)

(4) Package Type: TSOT23-6L

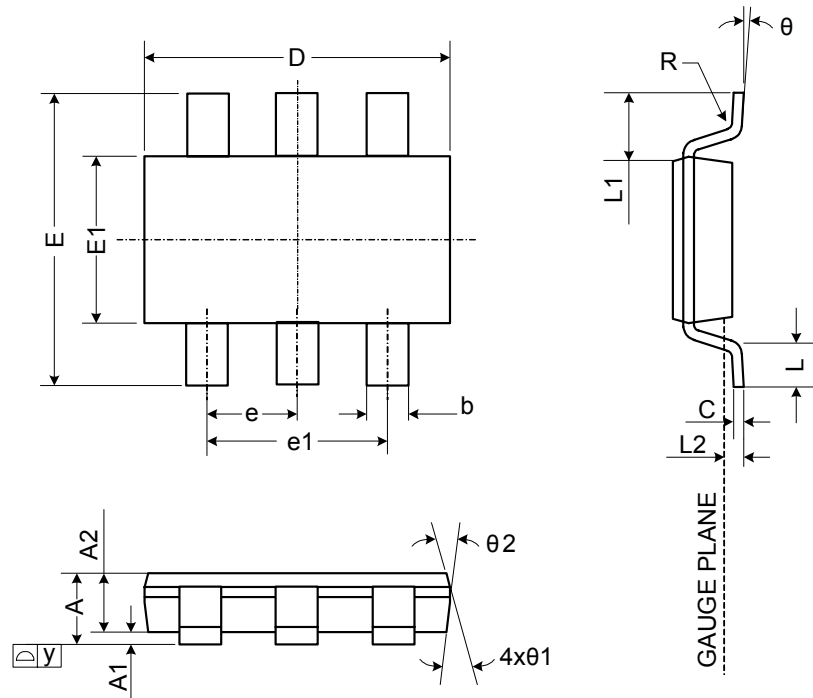

Symbol	Dimensions In Millimeters			Dimensions In Inches		
	Min.	Nom.	Max.	Min.	Nom.	Max.
A	0.75	-	0.90	0.030	-	0.035
A1	0.00	-	0.10	0.000	-	0.004
A2	0.70	0.75	0.80	0.028	0.030	0.031
b	0.35	-	0.51	0.014	-	0.020
C	0.10	-	0.25	0.004	-	0.010
D	2.80	2.90	3.00	0.110	0.114	0.118
E	2.60	2.80	3.00	0.102	0.110	0.118
E1	1.50	1.60	1.70	0.059	0.063	0.067
e	0.95 BSC.			0.037		
e1	1.90 BSC.			0.075		
L	0.37	-	-	0.015	-	-
L1	0.60 REF.			0.024		
L2	0.25 BSC.			0.010		
y	-	-	0.10	-	-	0.004
R	0.10	-	-	0.004	-	-
theta	0°	-	8°	0°	-	8°
theta1	7° NOM.			7° NOM.		
theta2	5° NOM.			5° NOM.		



中发网 WWW.ZFA.CN

全球最大的PDF中文下载站



**中发网**  
www.zfa.cn

**PDF 资料下载尽在中发网**