



## AME8833/8834

## High PSRR, 150mA CMOS LDO

### General Description

The AME8833 family of positive, linear regulators feature low quiescent current (50 $\mu$ A typ.) low dropout voltage and excellent PSRR, thus making them ideal for Telecommunications and other battery applications. The ultra-small SC-70 package is attractive for "Pocket" and "Hand Held" applications.

AME8834's output voltage can be adjusted with an external resistor divider.

These rugged devices have both Thermal Shutdown, and Current Fold-back to prevent device failure under the "Worst" of operating conditions.

As an additional feature, the AME8833/8834 is stable with an output capacitance of just extended 0.22 $\mu$ F or greater.

### Features

- Stable with only 0.22 $\mu$ F output Cap
- Very Low Dropout Voltage
- Guaranteed 150mA Output
- Accurate to within 1.0%
- 50 $\mu$ A Quiescent Current
- Over-Temperature Shutdown
- Current Limiting
- Short Circuit Current Fold-back
- Excellent PSRR (Typ. 70dB)
- Power-Saving Shutdown Mode
- Ultra-small SC-70 and TSOT-25 Package
- Factory Pre-set Output Voltages
- Low Temperature Coefficient
- Input Voltage Range (2V - 5.5V)

### Applications

- Cellular Phones
- Instrumentation
- Portable Electronics
- Wireless Devices
- Cordless Phones
- PC Peripherals
- Battery Powered Widgets
- Electronic Scales
- Cameras
- Telecommunications

### Functional Block Diagram

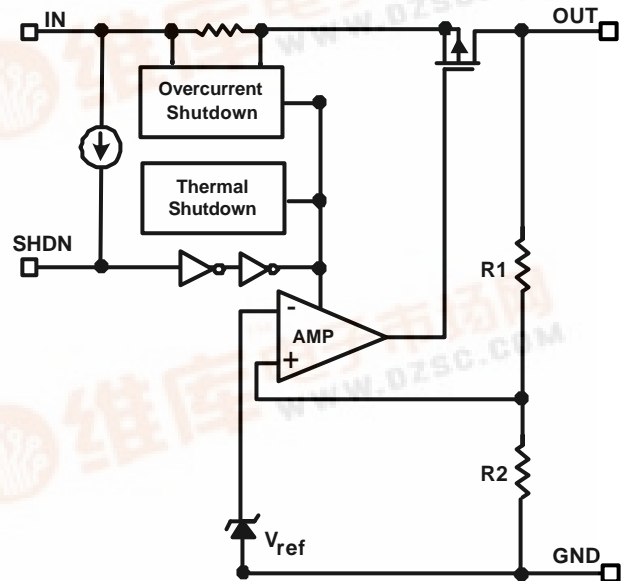

### Typical Application

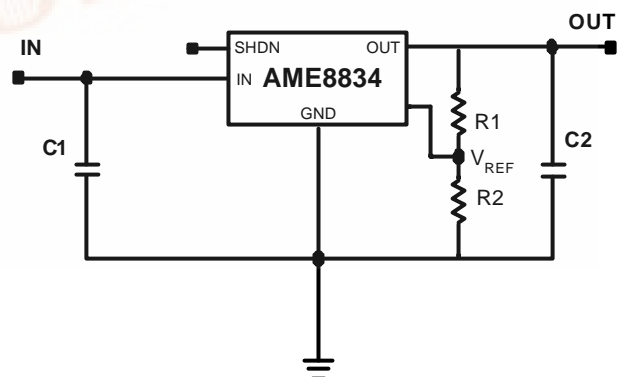
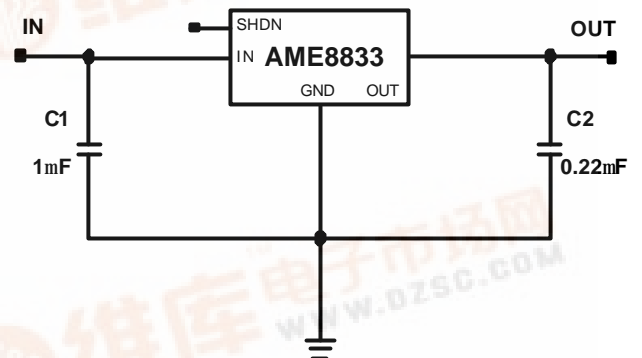

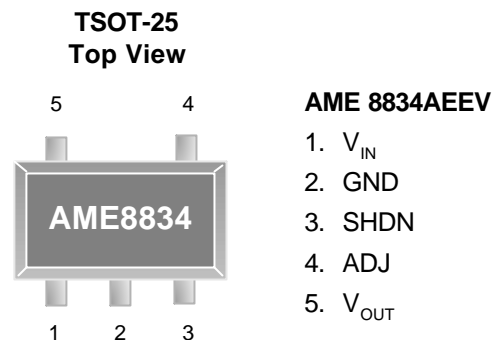
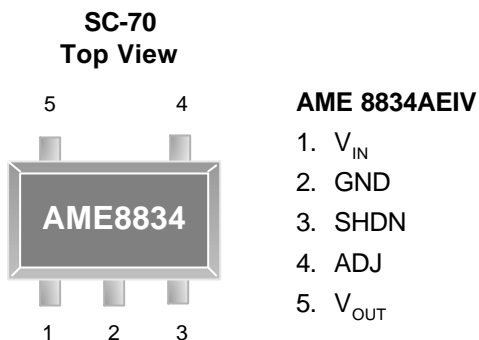
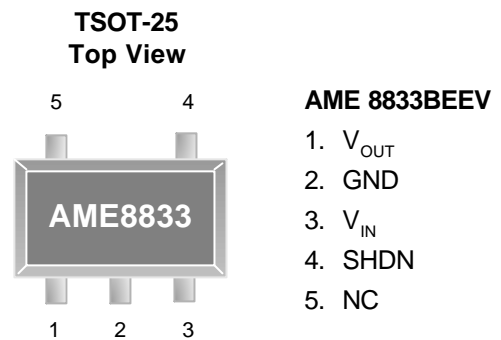
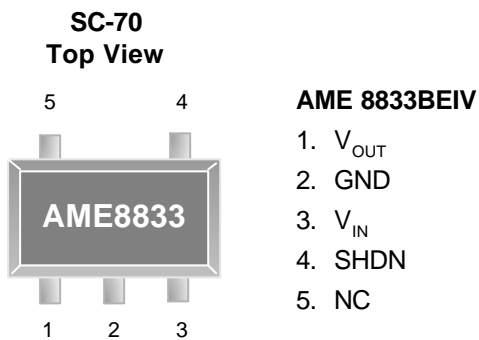
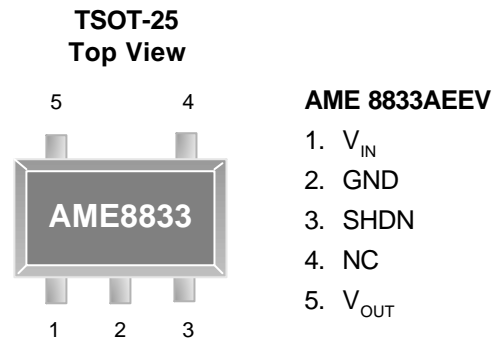
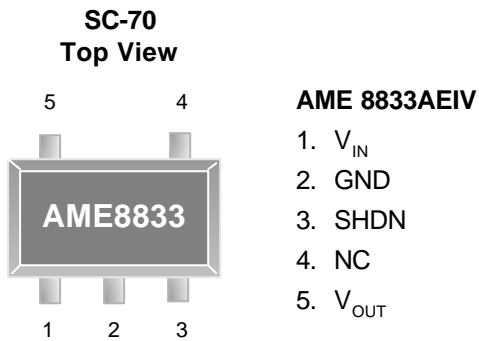
**■ Pin Configuration**



■ Ordering Information

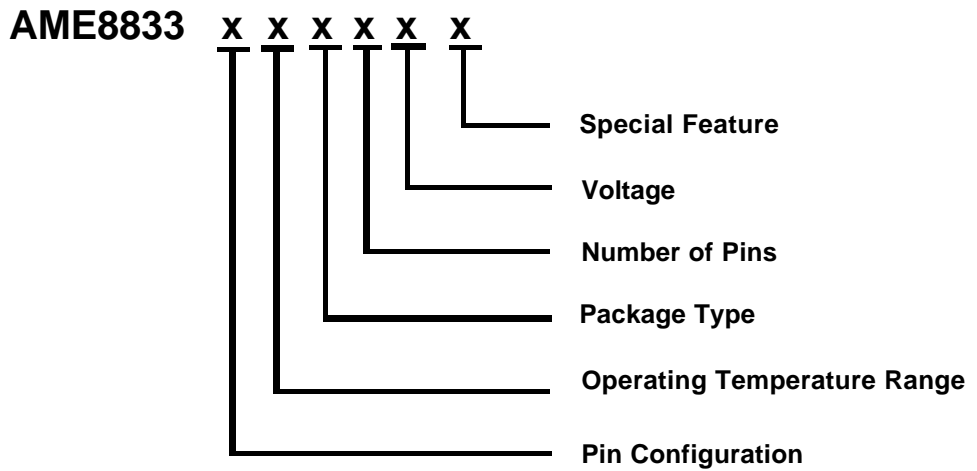

Pin Configuration	Operating Temperature Range	Package Type	Number of Pins	Voltage	Special Feature
A: 1. VIN 2. GND 3. SHDN 4. NC 5. VOUT  B: 1. VOUT 2. GND 3. VIN 4. SHDN 5. NC	E: -40°C to 85°C	E: SOT-2X I: SC-70	V: 5	150: V=1.5V 180: V=1.8V 200: V=2.0V 250: V=2.5V 270: V=2.7V 280: V=2.8V 285: V=2.85V 300: V=3.0V 320: V=3.2V 330: V=3.3V	L: Low profile Y: Lead free & Low profile Z: Lead free

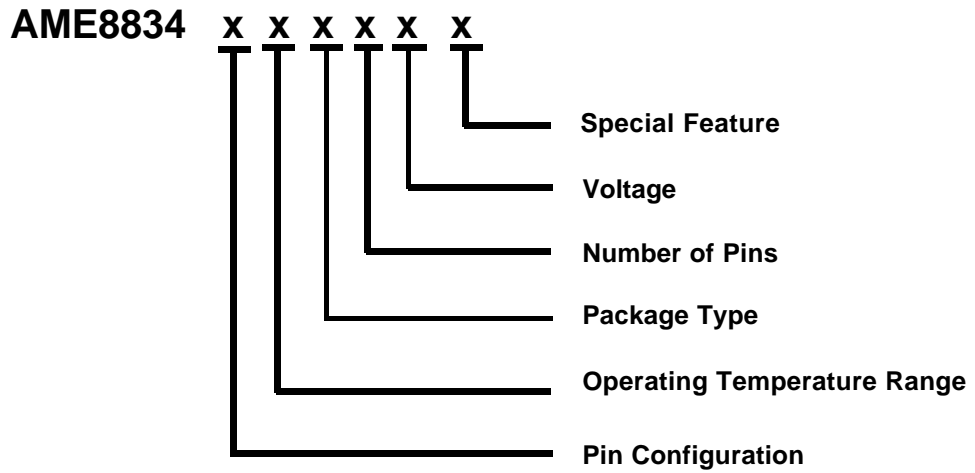
**■ Ordering Information**

Pin Configuration	Operating Temperature Range	Package Type	Number of Pins	Voltage	Special Feature
A: 1. VIN 2. GND 3. SHDN 4. ADJ 5. VOUT	E: -40°C to 85°C	E: SOT-2X I: SC-70	V: 5	ADJ: Adjustable	L: Low profile Y: Lead free & Low profile Z: Lead free



**AME8833/8834**

**High PSRR, 150mA CMOS LDO**

**■ Ordering Information**

Part Number	Marking*	Output Voltage	Package	Operating Temp. Range
AME8833AEIV180	AWAw	1.8V	SC-70	- 40°C to + 85°C
AME8833AEIV180Z	AWAw	1.8V	SC-70	- 40°C to + 85°C
AME8833AEIV250	AWBw	2.5V	SC-70	- 40°C to + 85°C
AME8833AEIV250Z	AWBw	2.5V	SC-70	- 40°C to + 85°C
AME8833AEIV270	AXFw	2.7V	SC-70	- 40°C to + 85°C
AME8833AEIV270Z	AXFw	2.7V	SC-70	- 40°C to + 85°C
AME8833AEIV280	AWDw	2.8V	SC-70	- 40°C to + 85°C
AME8833AEIV280Z	AWDw	2.8V	SC-70	- 40°C to + 85°C
AME8833AEIV285	AVZw	2.85V	SC-70	- 40°C to + 85°C
AME8833AEIV285Z	AVZw	2.85V	SC-70	- 40°C to + 85°C
AME8833AEIV300	AWEw	3.0V	SC-70	- 40°C to + 85°C
AME8833AEIV300Z	AWEw	3.0V	SC-70	- 40°C to + 85°C
AME8833AEIV320	AXGw	3.2V	SC-70	- 40°C to + 85°C
AME8833AEIV320Z	AXGw	3.2V	SC-70	- 40°C to + 85°C
AME8833AEIV330	AWCw	3.3V	SC-70	- 40°C to + 85°C
AME8833AEIV330Z	AWCw	3.3V	SC-70	- 40°C to + 85°C
AME8834AEIVADJ	AWJw	Adjustable	SC-70	- 40°C to + 85°C
AME8834AEIVADJZ	AWJw	Adjustable	SC-70	- 40°C to + 85°C

Note: w represents date code ( A thru Z ) : 2 work weeks per character.

ww represents date code

A line on top of the first letter represents lead free plating such as AWA

Please consult AME sales office or authorized Rep./Distributor for other output voltage and package type availability.

**■ Ordering Information**

Part Number	Marking*	Output Voltage	Package	Operating Temp. Range
AME8833AEEV180L	AWMww	1.8V	TSOT-25	- 40°C to + 85°C
AME8833AEEV180Y	AWMww	1.8V	TSOT-25	- 40°C to + 85°C
AME8833AEEV250L	AWNww	2.5V	TSOT-25	- 40°C to + 85°C
AME8833AEEV250Y	AWNww	2.5V	TSOT-25	- 40°C to + 85°C
AME8833AEEV270L	AXEww	2.7V	TSOT-25	- 40°C to + 85°C
AME8833AEEV270Y	AXEww	2.7V	TSOT-25	- 40°C to + 85°C
AME8833AEEV280L	AWOww	2.8V	TSOT-25	- 40°C to + 85°C
AME8833AEEV280Y	AWOww	2.8V	TSOT-25	- 40°C to + 85°C
AME8833AEEV285L	AWPww	2.85V	TSOT-25	- 40°C to + 85°C
AME8833AEEV285Y	AWPww	2.85V	TSOT-25	- 40°C to + 85°C
AME8833AEEV300L	AWQww	3.0V	TSOT-25	- 40°C to + 85°C
AME8833AEEV300Y	AWQww	3.0V	TSOT-25	- 40°C to + 85°C
AME8833AEEV330L	AWRww	3.3V	TSOT-25	- 40°C to + 85°C
AME8833AEEV330Y	AWRww	3.3V	TSOT-25	- 40°C to + 85°C
AME8834AEEVADJL	BABww	Adjustable	TSOT-25	- 40°C to + 85°C
AME8834AEEVADJY	BABww	Adjustable	TSOT-25	- 40°C to + 85°C

**■ Absolute Maximum Ratings**

Parameter	Maximum	Unit
Input Voltage	6	V
Output Current	$P_D / (V_{IN} - V_O)$	mA
Output Voltage	GND - 0.3 to $V_{IN} + 0.3$	V
ESD Classification	B	

Caution: Stress above the listed absolute maximum rating may cause permanent damage to the device

**■ Recommended Operating Conditions**

Parameter	Rating	Unit
Ambient Temperature Range	- 40 to + 85	°C
Junction Temperature	- 40 to + 125	°C

**■ Thermal Information**

Parameter		Maximum	Unit
Thermal Resistance ( $\theta_{ja}$ )	TSOT-25	260	°C / W
Thermal Resistance ( $\theta_{ja}$ )	SC-70	331	°C / W
Maximum Junction Temperature		150	°C
Maximum Lead Temperature (10 Sec)		300	°C



## AME8833/8834

## High PSRR, 150mA CMOS LDO

### Electrical Specifications

$V_{OUT} > 2.0V$   $V_{IN}=V_{OUT}+0.5V$ ;  $V_{OUT} \leq 2.0V$   $V_{IN}=V_{OUT}+1V$ ,  $V_{SHDN}=V_{IN}$ ,  $T_A = 25^{\circ}C$ ,  $C_{IN}=C_{OUT}=1\mu F$ , AME8834 is tested with 2.45V output, unless otherwise noted

Parameter	Symbol	Test Condition		Min	Typ	Max	Units	
Input Voltage	$V_{IN}$			Note1		5.5	V	
Output Voltage Accuracy	$V_O$	$I_O=0.1mA$	AME8833	$V_O \geq 2.0V$	25°C	-1	1	%
					-40°C~85°C	-2	2	
			$V_O < 2.0V$	25°C	-1.5	1.5		
				-40°C~85°C	-2	2		
		AME8834		25°C	-1.5	1.5	%	
				-40°C~85°C	-2.5	2.5		
		$I_O=150mA$	AME8833	25°C	-2	2		
				-40°C~85°C	-2.5	2.5		
AME8834	25°C		-2	2				
	-40°C~85°C		-2.5	2.5				
Dropout Voltage	$V_{DROPOUT}$	$I_O=150mA$	$V_O \geq 2.0V$	25°C		300	500	mV
				-40°C~85°C			600	
		$V_{OUT}=V_{O(NOM)}-2\%$	$1.8V \leq V_O < 2.0V$	25°C		700	1000	
				-40°C~85°C			1100	
		$1.5V \leq V_O < 1.8V$	25°C		900	1300		
			-40°C~85°C			1400		
Current Limit	$I_{LIM}$	$V_O > 800mV$		150	200		mA	
Foldback Current	$I_{FB}$	$V_O=0V$			80		mA	
Quiescent Current	$I_Q$	$V_{IN}=5V, I_O=0mA$			60		$\mu A$	
Ground Pin Current	$I_{GND}$	$V_{IN}=5V, I_O=1mA$ to 150mA			50		$\mu A$	
Line Regulation	REG <sub>LINE</sub>	$I_O=0.1mA, V_{OUT}>2.0V$	$V_{IN}=V_{OUT}+0.5V$ to 5.5V	25°C	-0.2	0.1	0.2	%
				-40°C~85°C	-0.3		0.3	
		$I_O=0.1mA, V_{OUT}\leq 2.0V$	$V_{IN}=V_{OUT}+1V$ to 5.5V	25°C	-0.4		0.4	
				-40°C~85°C	-0.5		0.5	
Load Regulation	REG <sub>LOAD</sub>	$I_O=0.1$ to 150mA	$V_{OUT}>2.0V$	25°C	-1	0.5	1	%
				-40°C~85°C	-1.5		1.5	
		$V_{OUT}\leq 2.0V$	$V_{IN}=V_{OUT}+1V$	25°C	-2		2	
				-40°C~85°C	-2.5		2.5	
Over Temperature Shutdown	OTS				137		°C	
Over Temperature Hysterisis	OTH				23		°C	
$V_O$ Temperature Coefficient	TC				30		ppm/°C	
Power Supply Rejection	PSRR	$R_O=100\Omega, C_O=0.22mF$		$f=1kHz$		70		dB
Output Voltage Noise	eN	$f=10Hz$ to 100kHz, $I_O=10mA$		$C_O=0.22\mu F$		30		$\mu V_{rms}$
SHDN Input Threshold	$V_{SHDNH}$	$V_{SHDN} = 0.8 \times V_{IN}$		$0.8 \times V_{IN}$		$V_{in}$	V	
	$V_{SHDNL}$	$V_{SHDN} = 0.6V$		0		0.6	V	
SHDN Input Bias Current		$V_{IN} = 5V$	EN = 0V or 5V	TA= 25°C		0.01		$\mu A$
				TA= 85°C		0.1		
Shutdown Supply Current	$I_{SD}$	$V_{IN}=5V$	$V_O=0V$	TA=25°C		0.5	1	$\mu A$
				TA=85°C		1		
Shutdown Output Voltage	$V_{O,SD}$	Output Loading $\leq 1200$ ohm, $V=0V$			0		0.4	V
ADJ Refernece Voltage (AME8834)	$V_{REF}$	T= 25°C			1.206	1.225	1.243	V
ADJ Input Bias Current (AME8834)		$V_{IN}=5.5V$	$V_{ADJ}=1.3V$	TA= 25°C		0.05	0.1	$\mu A$
				TA= 85°C		0.1		

Note1:  $V_{IN(min)}=V_{OUT}+V_{DROPOUT}$

Note2: All over temperature range SPECS are guaranteed by design



## ■ Detailed Description

The AME8833/8834 family of CMOS regulators contain a PMOS pass transistor, voltage reference, error amplifier, over-current protection, and thermal shutdown.

The P-channel pass transistor receives data from the error amplifier, over-current shutdown, and thermal protection circuits. During normal operation, the error amplifier compares the output voltage to a precision reference. Over-current and Thermal shutdown circuits become active when the junction temperature exceeds 150°C, or the current exceeds 150mA. During thermal shutdown, the output voltage remains low. Normal operation is restored when the junction temperature drops below 120°C.

The AME8833/8834 switches from voltage mode to current mode when the load exceeds the rated output current. This prevents over-stress. The AME8833/8834 also incorporates current foldback to reduce power dissipation when the output is short circuited. This feature becomes active when the output drops below 0.8volts, and reduces the current flow by 65%. Full current is restored when the voltage exceeds 0.8 volts.

## ■ External Capacitors

The AME8833/8834 is stable with an output capacitor to ground of 0.22µF or greater. Ceramic capacitors have the lowest ESR, and will offer the best AC performance. Conversely, Aluminum Electrolytic capacitors exhibit the highest ESR, resulting in the poorest AC response.

A second capacitor is recommended between the input and ground to stabilize  $V_{in}$ . The input capacitor should be at least 1µF to have a beneficial effect.

A larger capacitor improves the AC ripple rejection, but also makes the output come up slowly. This "Soft" turn-on is desirable in some applications to limit turn-on surges.

All capacitors should be placed in close proximity to the pins. A "Quiet" ground termination is desirable. This can be achieved with a "Star" connection.

## ■ Shutdown

When actively, pulled low, the PMOS pass transistor shuts off, and all internal circuits are powered down. In this state, the quiescent current is less than 1µA. This pin behaves much like an electronic switch.

## ■ Adjustable Version

AME8834 features a user-adjustable output through an external feedback resistor divider. To set the output of AME8834 use the following equation:

$$V_{OUT} = V_{ADJ} (1 + R1/R2)$$
$$V_{ADJ} = 1.225V, \text{ use } 1\% \text{ or better resistors}$$

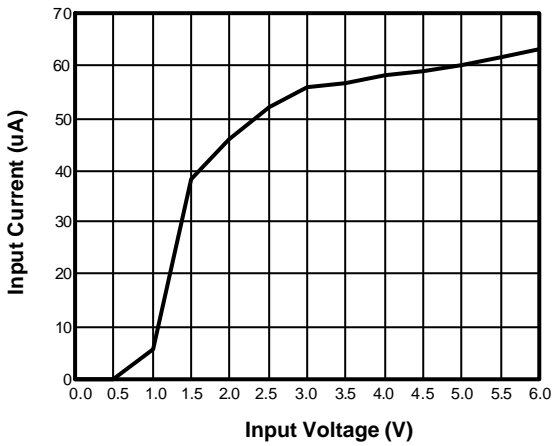
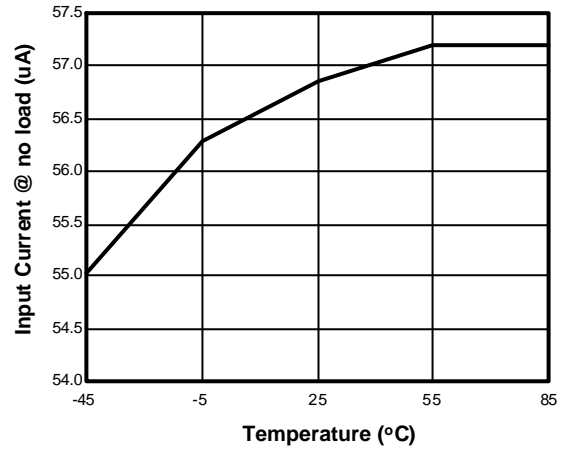
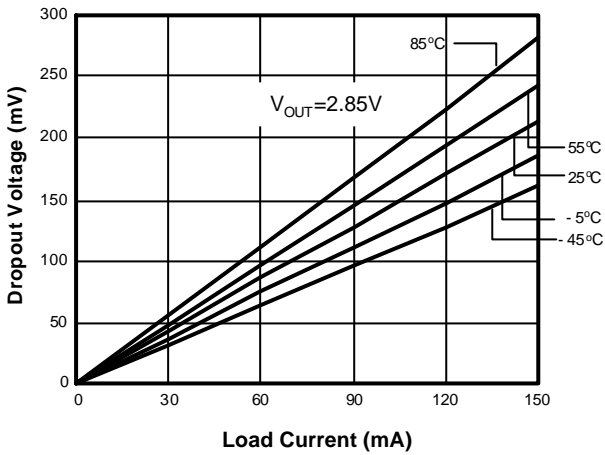
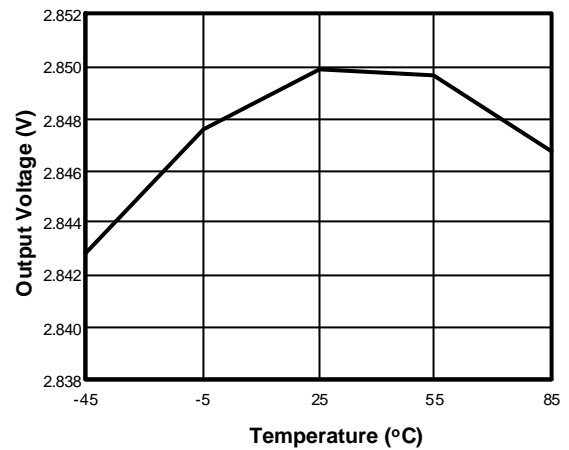
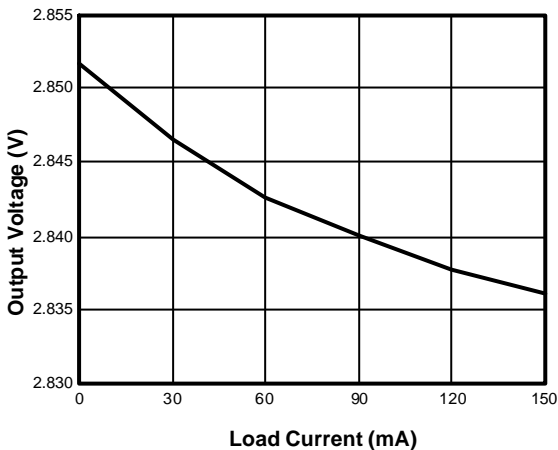
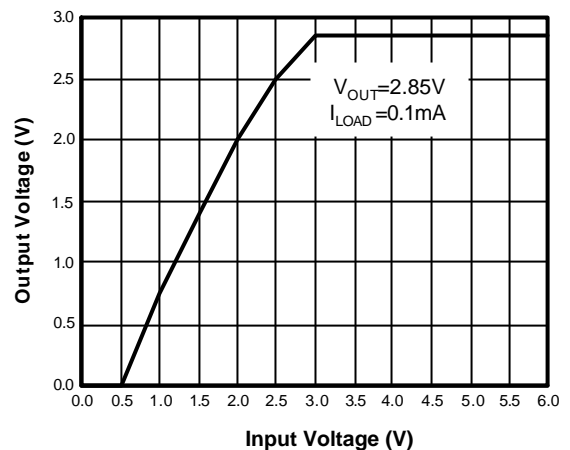
**Input Current vs. Input Voltage**

**Input Current vs. Temperature**

**Dropout Voltage vs. Load**

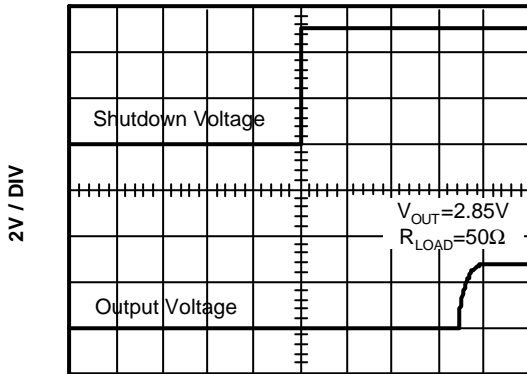
**Output Voltage vs. Temperature**

**Output Voltage vs. Load Current**

**Output Voltage vs. Input Voltage**



Exiting Shutdown Waveform



10 mS / DIV

Entering Shutdown Waveform

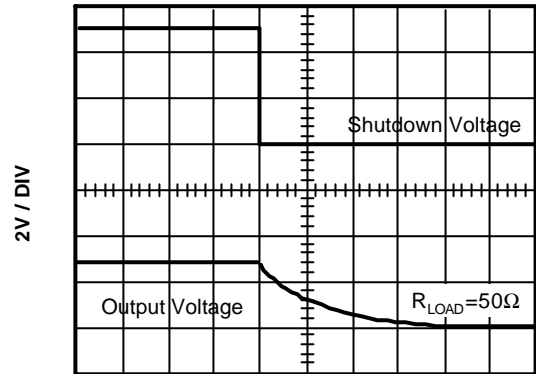

10 mS / DIV

Output Noise Spectral Density vs. Frequency

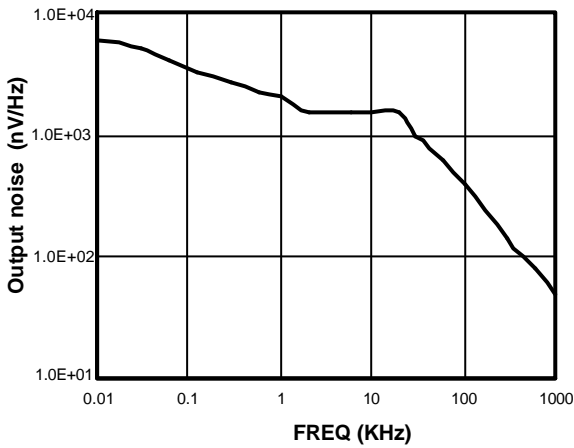

Line Transient Response

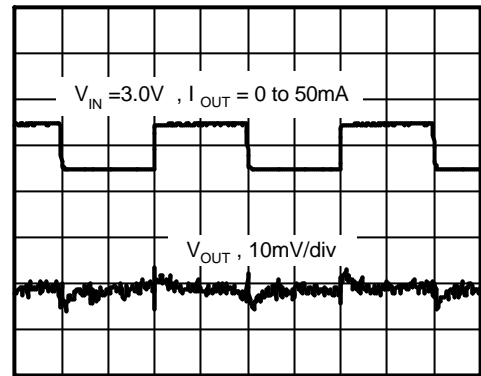

200uS/div

Load Transient Response

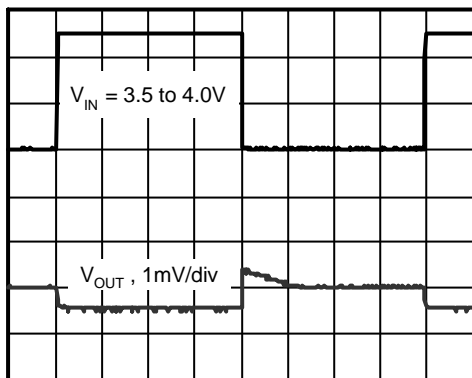

1mS/div

PSRR vs. Frequency

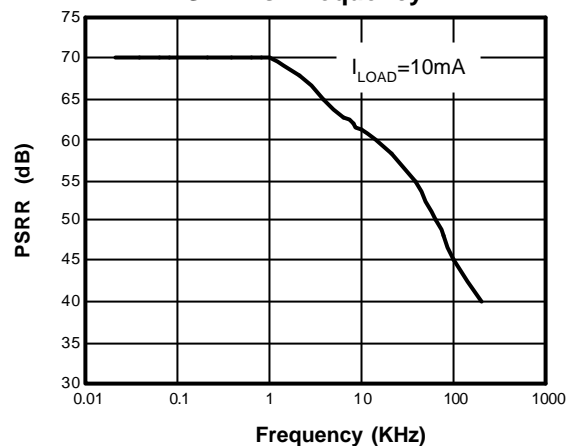

Dropout Voltage vs. Output Voltage

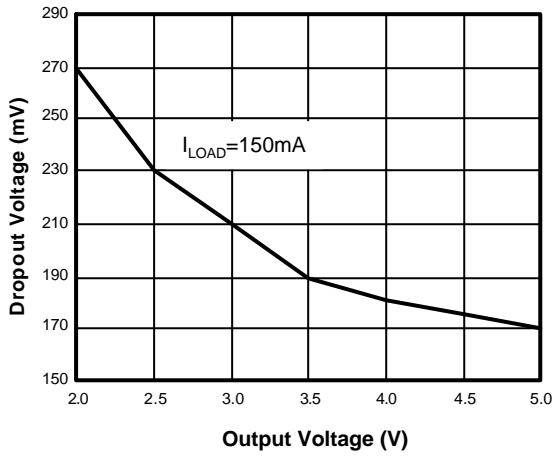

Region of Stable Cout ESR vs. Load Current

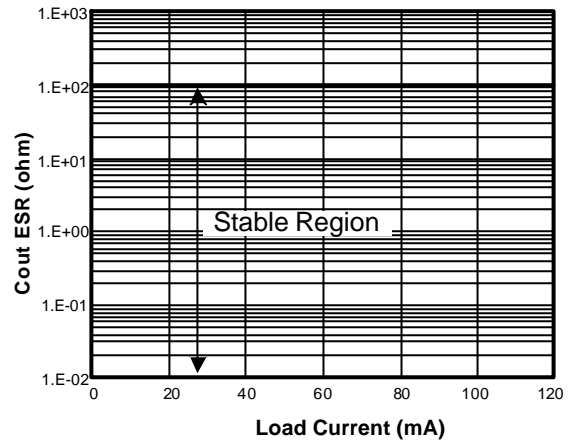

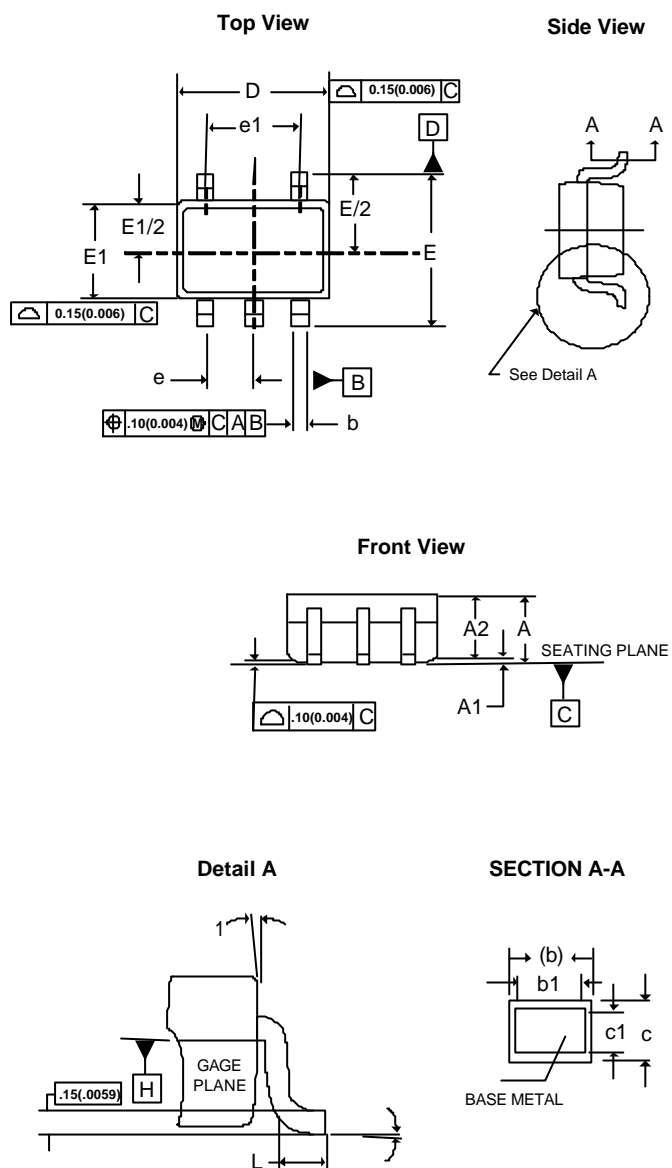
**■ Package Dimension**
**SC-70**

SYMBOLS	MILLIMETERS		INCHES	
	MIN	MAX	MIN	MAX
<b>A</b>	0.80	1.10	0.031	0.043
<b>A1</b>	0.00	0.10	0.000	0.004
<b>A2</b>	0.80	1.00	0.031	0.040
<b>b</b>	0.15	0.30	0.006	0.012
<b>b1</b>	0.15	0.25	0.006	0.010
<b>c</b>	0.08	0.25	0.003	0.010
<b>c1</b>	0.08	0.20	0.003	0.008
<b>D</b>	1.90	2.15	0.074	0.084
<b>E</b>	2.00	2.20	0.078	0.086
<b>E1</b>	1.15	1.35	0.045	0.055
<b>e</b>	0.65BSC		0.0255BSC	
<b>e1</b>	1.30BSC		0.0512BSC	
<b>L</b>	0.26	0.46	0.010	0.018
<b>q1</b>	0°	8°	0°	8°
<b>q2</b>	4°	10°	4°	10°

**NOTE:**

1. Controlling Dimension : Millimeter, converted inch dimension are not necessarily exact.
2. Dimensioning and tolerancing per ansi Y14.5m-1994.
3. Dimension "d" does not include mold flash, protrusion or gate burr, mold flash, protrusion or gate burr shall not exceed 0.15mm(0.006") per end. Dimension E1 do not include inter-lead flash or protrusion, inter-lead flash or protrusion shall not exceed 0.15mm(0.006") per side.
4. The package top be smaller than the package bottom. Dimension D and E1 are determined at outermost extremes of the plastic body exclusive of mold flash, tie bar burrs, gate burrs and interlead flash, but including any mismatch between the top and bottom of the plastic body.

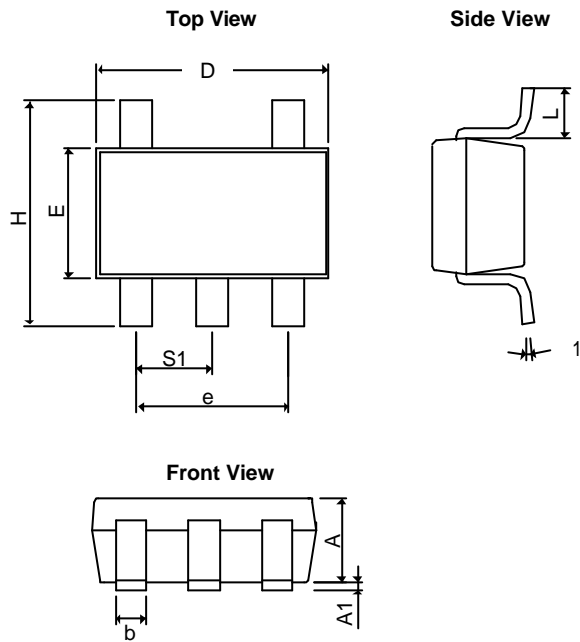
**■ Package Dimension**
**TSOT-25**

SYMBOLS	MILLIMETERS		INCHES	
	MIN	MAX	MIN	MAX
$A+A_1$	1.00	1.30	0.0394	0.0512
$b$	0.30	0.55	0.0118	0.0217
$D$	2.70	3.10	0.1063	0.1220
$E$	1.40	1.80	0.0551	0.0709
$e$	1.90 BSC		0.07480 BSC	
$H$	2.60	3.00	0.10236	0.11811
$L$	0.37BSC		0.0146BSC	
$\theta_1$	0°	10°	0°	10°
$S_1$	0.95BSC		0.0374BSC	



**www.ame.com.tw**  
**E-Mail: sales@ame.com.tw**

Life Support Policy:

These products of AME, Inc. are not authorized for use as critical components in life-support devices or systems, without the express written approval of the president of AME, Inc.

AME, Inc. reserves the right to make changes in the circuitry and specifications of its devices and advises its customers to obtain the latest version of relevant information.

© AME, Inc. , June 2005

Document: 2029-DS8833/8834-H

**Corporate Headquarter**  
**AME, Inc.**

2F, 302 Rui-Guang Road, Nei-Hu District  
Taipei 114, Taiwan.  
Tel: 886 2 2627-8687  
Fax: 886 2 2659-2989

**U.S.A.(Subsidiary)**  
**Analog Microelectronics, Inc.**

3100 De La Cruz Blvd., Suite 201  
Santa Clara, CA. 95054-2046  
Tel : (408) 988-2388  
Fax: (408) 988-2489



中发网 WWW.ZFA.CN

全球最大的PDF中文下载站



**中发网**  
www.zfa.cn

**PDF 资料下载尽在中发网**