



AME8816

1.5A CMOS LDO

General Description

The AME8816 family of positive, linear regulators feature low quiescent current (45µA typ.) with low dropout voltage, making them ideal for battery applications.

Output voltages are set at the factory and trimmed to 1.5% accuracy.

These rugged devices have both Thermal Shutdown, and Current Fold-back to prevent device failure under the "Worst" of operating conditions.

In applications requiring a low noise, regulated supply, place a 1000pF capacitor between Bypass and Ground.

The AME8816 is stable with an output capacitance of 4.7µF or greater.

Features

- Very Low Dropout Voltage
- Guaranteed 1.5A Output
- Accurate to within 1.5%
- 45µA Quiescent Current Typically
- Over-Temperature Shutdown
- Current Limiting
- Short Circuit Current Fold-back
- Noise Reduction Bypass Capacitor (Fixed Versions)
- Power-Saving Shutdown Mode
- Space-Saving DDPAK-5, SO-8 Package
- 6 Factory Pre-set Output Voltages
- Low Temperature Coefficient
- Adjustable Version

Applications

- Instrumentation
- Portable Electronics
- Wireless Devices
- PC Peripherals
- Battery Powered Widgets

Functional Block Diagram (Fixed Versions)

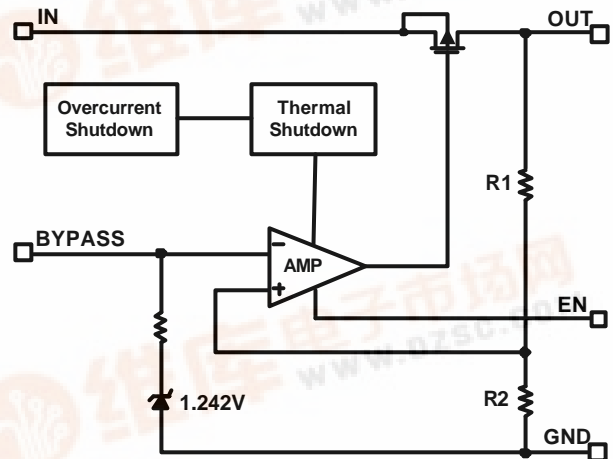

Functional Block Diagram (Adjustable Version)

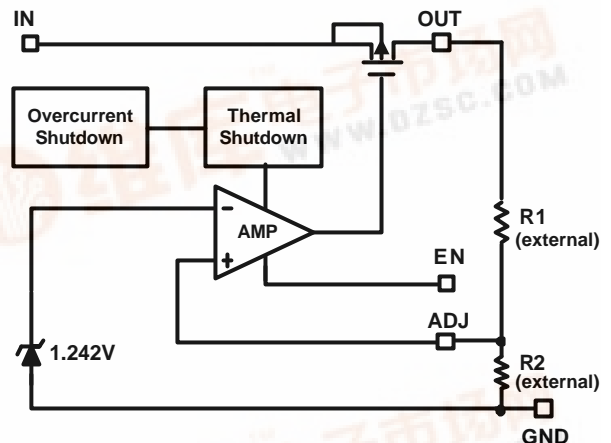

Typical Application

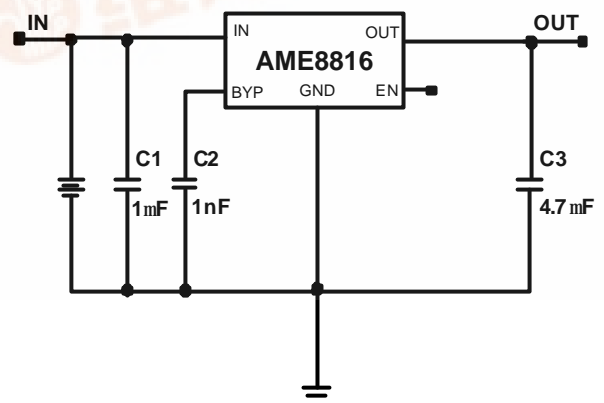

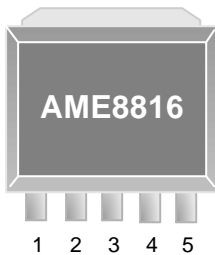
■ Pin Configuration
**TO-263(DDPAK-5)
Top View**

AME 8816AEDVxxx

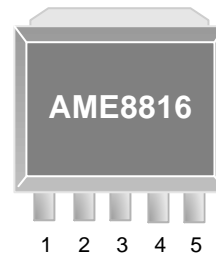
1. EN
2. V_{IN}
3. GND
4. V_{OUT}
5. BYP

**TO-263(DDPAK-5)
Top View**

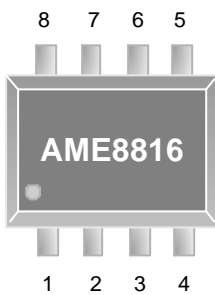
AME8816BEDVADJ

1. EN
2. V_{IN}
3. GND
4. V_{OUT}
5. ADJ

**SO-8
Top View**

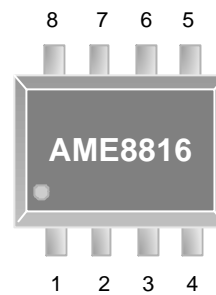
AME 8816AEHAxxx

1. BYP
2. GND
3. GND
4. EN
5. V_{IN}
6. GND
7. GND
8. V_{OUT}

**SO-8
Top View**

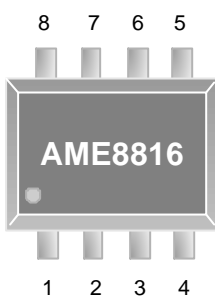
AME 8816BEHAADJ

1. ADJ
2. GND
3. GND
4. EN
5. V_{IN}
6. GND
7. GND
8. V_{OUT}

**SO-8
Top View**

AME 8816CEHAADJ

1. EN
2. V_{IN}
3. V_{OUT}
4. ADJ
5. GND
6. GND
7. GND
8. GND

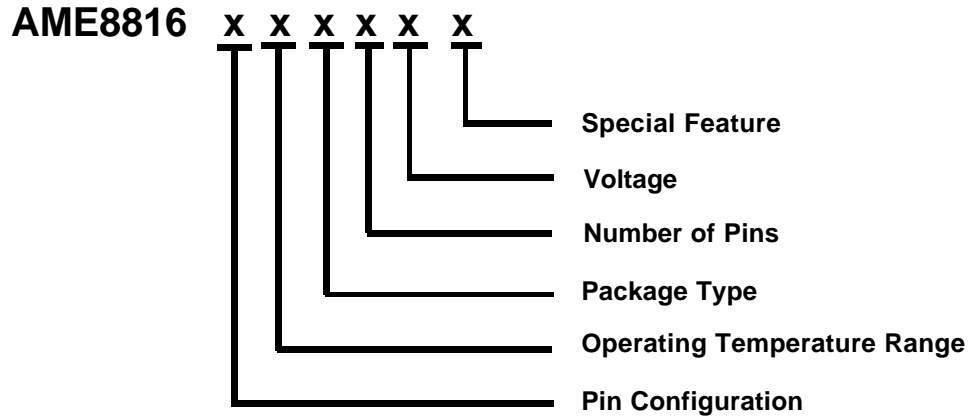

■ Ordering Information



Pin Configuration	Operating Temperature Range	Package Type	Number of Pins	Voltage	Special Feature
A (TO-263) 1. EN 2. VIN 3. GND 4. VOUT 5. BYP	E: -40°C to 85°C	D: TO-263 H: SO-8	A: 8 V: 5	ADJ: Adjustable 150: V=1.5V 180: V=1.8V 250: V=2.5V 330: V=3.3V 475: V=4.75V 500: V=5.0V	Z: Lead Free
B (TO-263) 1. EN 2. VIN 3. GND 4. VOUT 5. ADJ					
A (SO-8) 1. BYP 2. GND 3. GND 4. EN 5. VIN 6. GND 7. GND 8. VOUT					
B (SO-8) 1. ADJ 2. GND 3. GND 4. EN 5. VIN 6. GND 7. GND 8. VOUT					
C (SO-8) 1. EN 2. VIN 3. VOUT 4. ADJ 5. GND 6. GND 7. GND 8. GND					

■ Ordering Information (contd.)

Part Number	Marking*	Output Voltage	Package	Operating Temp. Range
AME8816AEDV150	AME8816 AEDV150 yyww	1.50	DDPAK-5	- 40°C to + 85°C
AME8816AEDV150Z	AME8816 AEDV150 yyww	1.50	DDPAK-5	- 40°C to + 85°C
AME8816AEDV180	AME8816 AEDV180 yyww	1.80	DDPAK-5	- 40°C to + 85°C
AME8816AEDV180Z	AME8816 AEDV180 yyww	1.80	DDPAK-5	- 40°C to + 85°C
AME8816AEDV250	AME8816 AEDV250 yyww	2.50	DDPAK-5	- 40°C to + 85°C
AME8816AEDV250Z	AME8816 AEDV250 yyww	2.50	DDPAK-5	- 40°C to + 85°C
AME8816AEDV330	AME8816 AEDV330 yyww	3.30	DDPAK-5	- 40°C to + 85°C
AME8816AEDV330Z	AME8816 AEDV330 yyww	3.30	DDPAK-5	- 40°C to + 85°C
AME8816AEDV475	AME8816 AEDV475 yyww	4.75	DDPAK-5	- 40°C to + 85°C
AME8816AEDV475Z	AME8816 AEDV475 yyww	4.75	DDPAK-5	- 40°C to + 85°C
AME8816AEDV500	AME8816 AEDV500 yyww	5.00	DDPAK-5	- 40°C to + 85°C
AME8816AEDV500Z	AME8816 AEDV500 yyww	5.00	DDPAK-5	- 40°C to + 85°C

■ Ordering Information (contd.)

Part Number	Marking*	Output Voltage	Package	Operating Temp. Range
AME8816BEDVADJ	AME8816 BEDVADJ yyww	ADJ	DDPAK-5	- 40°C to + 85°C
AME8816BEDVADJZ	AME8816 BEDVADJ yyww	ADJ	DDPAK-5	- 40°C to + 85°C
AME8816AEHA150	AME8816 AEHA150 yyww	1.50	SO-8	- 40°C to + 85°C
AME8816AEHA150Z	AME8816 AEHA150 yyww	1.50	SO-8	- 40°C to + 85°C
AME8816AEHA180	AME8816 AEHA180 yyww	1.80	SO-8	- 40°C to + 85°C
AME8816AEHA180Z	AME8816 AEHA180 yyww	1.80	SO-8	- 40°C to + 85°C
AME8816AEHA250	AME8816 AEHA250 yyww	2.50	SO-8	- 40°C to + 85°C
AME8816AEHA250Z	AME8816 AEHA250 yyww	2.50	SO-8	- 40°C to + 85°C
AME8816AEHA330	AME8816 AEHA330 yyww	3.30	SO-8	- 40°C to + 85°C
AME8816AEHA330Z	AME8816 AEHA330 yyww	3.30	SO-8	- 40°C to + 85°C
AME8816AEHA475	AME8816 AEHA475 yyww	4.75	SO-8	- 40°C to + 85°C
AME8816AEHA475Z	AME8816 AEHA475 yyww	4.75	SO-8	- 40°C to + 85°C

■ Ordering Information (contd.)

Part Number	Marking*	Output Voltage	Package	Operating Temp. Range
AME8816AEHA500	AME8816 AEHA500 yyww	5.00	SO-8	- 40°C to + 85°C
AME8816AEHA500Z	AME8816 AEHA500 yyww	5.00	SO-8	- 40°C to + 85°C
AME8816BEHAADJ	AME8816 BEHAADJ yyww	ADJ	SO-8	- 40°C to + 85°C
AME8816BEHAADJZ	AME8816 BEHAADJ yyww	ADJ	SO-8	- 40°C to + 85°C
AME8816CEHAADJ	AME8816 CEHAADJ yyww	ADJ	SO-8	- 40°C to + 85°C
AME8816CEHAADJZ	AME8816 CEHAADJ yyww	ADJ	SO-8	- 40°C to + 85°C

Note: yyww represents the date code

* A line on top of the first character represents lead free plating such as $\overline{\text{A}}$ ME8816

Please consult AME sales office or authorized Rep./Distributor for the availability of output voltage and package type.

■ Absolute Maximum Ratings

Parameter	Maximum	Unit
Input Voltage	8	V
Output Current	$P_D / (V_{IN} - V_O)$	mA
Output Voltage	GND - 0.3 to $V_{IN} + 0.3$	V
ESD Classification	B	

Caution: Stress above the listed absolute maximum rating may cause permanent damage to the device

■ Recommended Operating Conditions

Parameter	Rating	Unit
Ambient Temperature Range	- 40 to + 85	°C
Junction Temperature	- 40 to + 125	°C

■ Thermal Information

Parameter	Maximum	Unit
Maximum Junction Temperature	150	°C
Maximum Lead Temperature (10 Sec)	300	°C

■ Electrical Specifications

 $V_{IN} = V_{O(NOM)} + 2V$, $V_{EN} = V_{IN}$, $T_A = 25^{\circ}C$ unless otherwise noted

Parameter	Symbol	Test Condition	Min	Typ	Max	Units	
Input Voltage	V_{IN}		Note 1		7	V	
Output Voltage Accuracy	V_O	$V_{EN} = V_{EHmin}$, $I_O = 1mA$	-1.5		1.5	%	
Dropout Voltage	$V_{DROPOUT}$	$I_O = 1.5A$ $V_O = V_{O(NOM)} - 2.0\%$	$1.5V < V_{O(NOM)} \leq 2.0V$	See chart	1300	mV	
			$2.0V < V_{O(NOM)} \leq 2.8V$		800		
			$2.8V < V_{O(NOM)}$		600		
Output Current	I_O	$V_O > 1.2V$	1500			mA	
Current Limit	I_{LIM}	$V_O > 1.2V$	1500	2000		mA	
Short Circuit Current	I_{SC}	$V_O < 0.4V$		750		mA	
Quiescent Current (For Fixed Output Voltage Options)	I_Q	$I_O = 0mA$		45	70	μA	
Minimum Load Current (For ADJ Option)	I_{MIN}		1			mA	
Ground Pin Current	I_{GND}	$I_O = 1mA$ to 1.5A		45		μA	
Line Regulation	REG_{LINE}	$I_O = 1mA$ $V_{IN} = V_O + 1$ to $V_O + 2$	$V_O < 2.0V$	-0.15		0.15	%
			$4.0 > V_O \geq 2.0V$	-0.1	0.02	0.1	%
			$4.0V \leq V_O$	-0.4		0.4	%
Load Regulation	REG_{LOAD}	$I_O = 1mA$ to 1.5A	-1	0.2	1	%	
Over Temperature Shutdown	OTS			150		$^{\circ}C$	
Over Temperature Hysteresis	OTH			30		$^{\circ}C$	
V_O Temperature Coefficient	TC			30		ppm/ $^{\circ}C$	
ADJ Input Bias Current	I_{ADJ}	$V_{IN} = 5V$, $V_{ADJ} = 1.242V$		1		μA	
ADJ Reference Voltage	V_{REF}		1.223	1.242	1.261	V	
Power Supply Rejection	PSRR	$I_O = 100mA$ $C_O = 4.7\mu F$ ceramic	$f = 100Hz$				dB
			$f = 1kHz$		50		
			$f = 10kHz$		20		
Power Supply Rejection	PSRR	$I_O = 100mA$ $C_O = 4.7\mu F$ ceramic $C_{BYP} = 0.01\mu F$	$f = 100Hz$				dB
			$f = 1kHz$		75		
			$f = 10kHz$		55		
Output Voltage Noise	eN	$f = 10Hz$ to 100kHz $I_O = 10mA$, $C_{BYP} = 0\mu F$			30	μV_{rms}	
Output Voltage Noise	eN	$f = 10Hz$ to 100kHz $I_O = 10mA$, $C_{BYP} = 0.01\mu F$			30	μV_{rms}	
EN Input Threshold	V_{EH}		2.0		V_{IN}	V	
	V_{EL}		0		0.4	V	
EN Input Bias Current	I_{EH}	$V_{IN} = 7V$			0.1	μA	
	I_{EL}	$V_{EN} = 0V$, $V_{IN} = 7V$			0.5	μA	
Shutdown Supply Current	I_{SD}	$V_{IN} = 5V$, $V_O = 0V$, $V_{EN} = 0V$		0.5	2	μA	

 Note1: $V_{IN(min)} = V_{OUT} + V_{DROPOUT}$

 Note2: $V_{O(nom)}$: nominal output voltage of fixed version

■ Detailed Description

The AME8816 family of CMOS regulators contain a PMOS pass transistor, voltage reference, error amplifier, over-current protection, and thermal shutdown.

The P-channel pass transistor receives data from the error amplifier, over-current shutdown, and thermal protection circuits. During normal operation, the error amplifier compares the output voltage to a precision reference. Over-current and Thermal shutdown circuits become active when the junction temperature exceeds 140°C, or the current exceeds 2.2A. During thermal shutdown, the output voltage remains low. Normal operation is restored when the junction temperature drops below 120°C.

The AME8816 behaves like a current source when the load reaches 2.2A. However, if the load impedance drops below 0.3 ohms, the current drops back to 600mA to prevent excessive power dissipation. Normal operation is restored when the load resistance exceeds 0.75 ohms.

■ External Capacitors

The AME8816 is stable with an output capacitor to ground of 4.7µF or greater. Ceramic capacitors have the lowest ESR, and will offer the best AC performance. Conversely, Aluminum Electrolytic capacitors exhibit the highest ESR, resulting in the poorest AC response. Unfortunately, large value ceramic capacitors are comparatively expensive. One option is to parallel a 0.1µF ceramic capacitor with a 10µF Aluminum Electrolytic. The benefit is low ESR, high capacitance, and low overall cost.

A second capacitor is recommended between the input and ground to stabilize V_{in} . The input capacitor should be at least 0.1µF to have a beneficial effect.

A third capacitor can be connected between the BY-PASS pin and GND. This capacitor can be a low cost Polyester Film variety between the value of 0.001 ~ 0.01µF. A larger capacitor improves the AC ripple rejection, but also makes the output come up slowly. This "Soft" turn-on is desirable in some applications to limit turn-on surges.

All capacitors should be placed in close proximity to the pins. A "Quiet" ground termination is desirable. This can be achieved with a "Star" connection.

■ Enable

When pulled low, the PMOS pass transistor shuts off, and all internal circuits are powered down. In this state, the quiescent current is less than 1µA. This pin behaves much like an electronic switch.

100Kohm resistor is necessary between V_{EN} source and EN pin when V_{EN} is higher than V_{IN} .

(Note: There is no internal pull-up for EN PIN.)

■ Adjustable Version

The adjustable version uses external feedback resistors to generate an output voltage anywhere from 1.5V to 5.0V. V_{adj} is trimmed to 1.242V and V_{OUT} is given by the equation:

$$V_{OUT} = V_{adj} (1 + R1 / R2)$$

Feedback resistors R1 and R2 should be high enough to keep quiescent current low, but increasing $R1 + R2$ will reduce stability. In general, R1 and R2 in the 10 to 100 kΩ will produce adequate stability, given reasonable layout precautions. To improve stability characteristics, keep parasitics on the ADJ pin to a minimum, and lower R1 and R2 values.

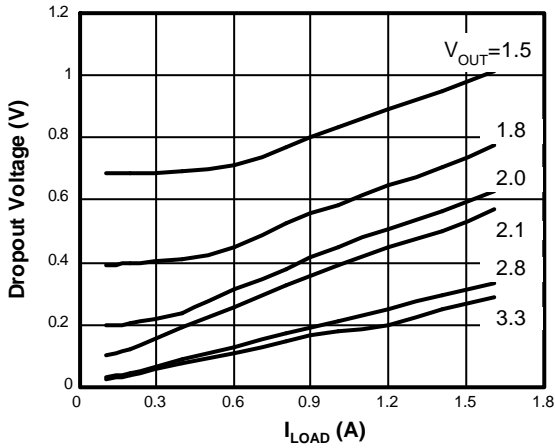
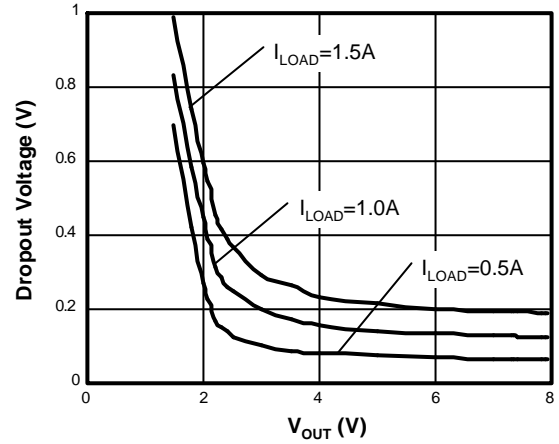
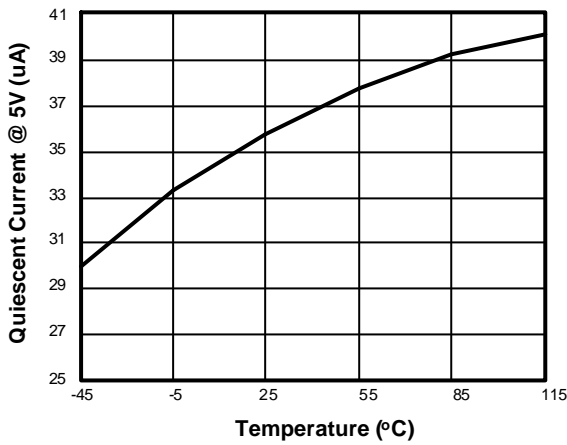
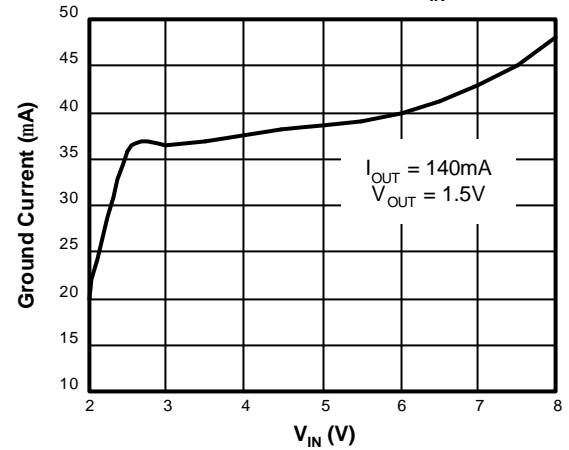
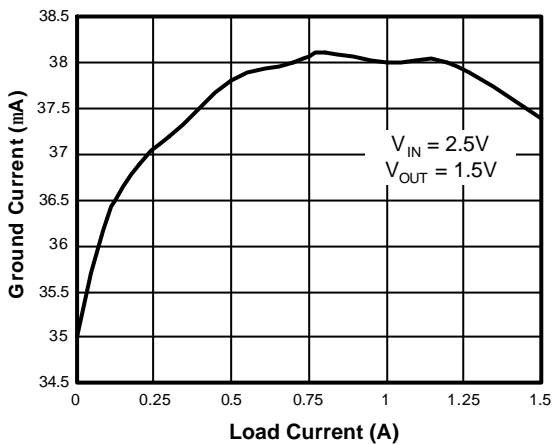
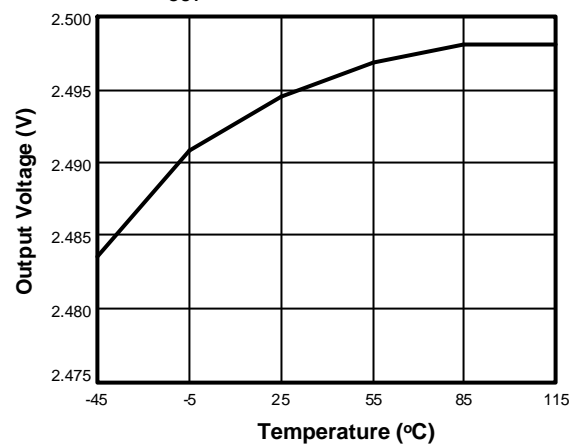
Dropout Voltage VS I_{LOAD}

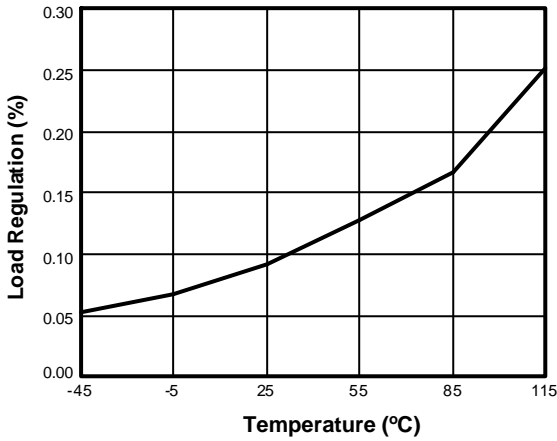
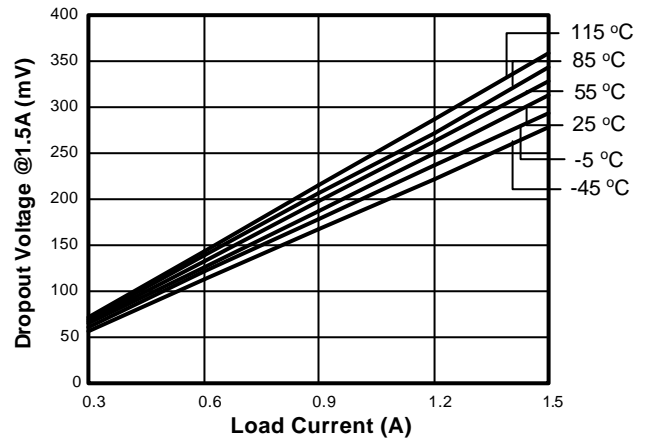
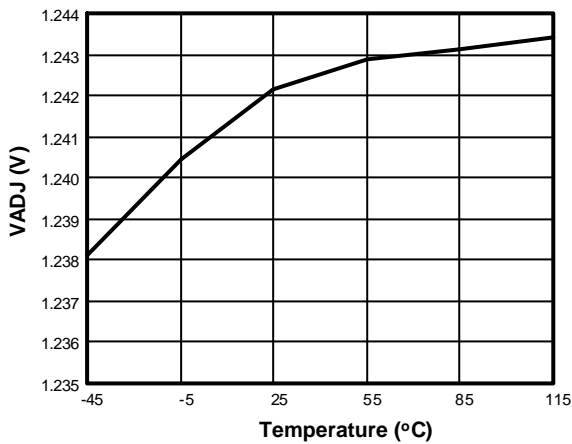
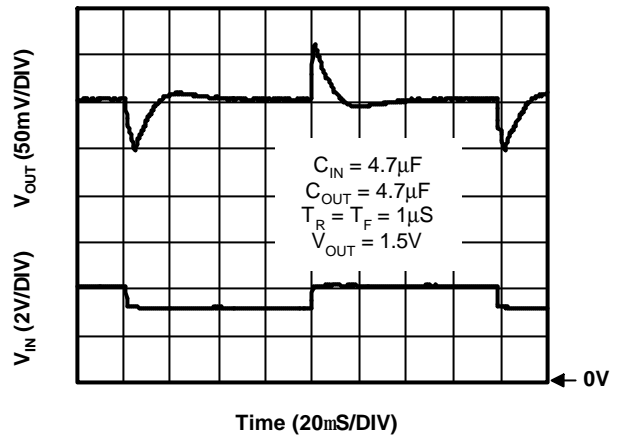
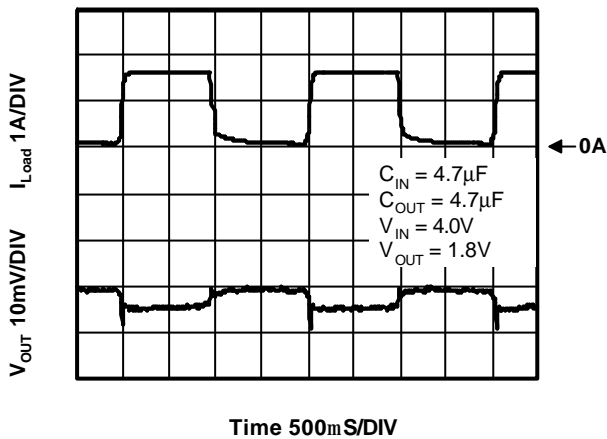
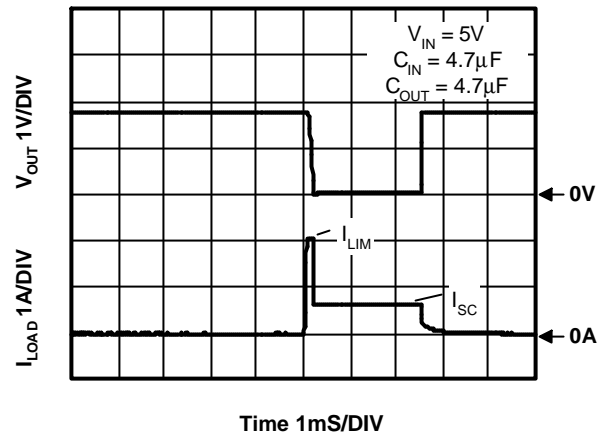
Dropout Voltage VS V_{OUT}

Quiescent Current vs. Temperature

Ground Current vs. V_{IN}

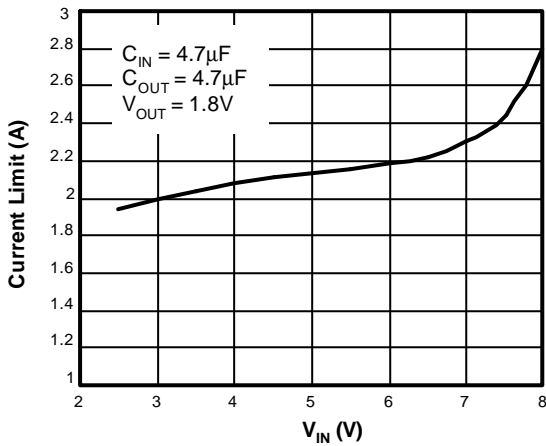
Ground Current vs. Load Current

 V_{OUT} vs. Temperature(2.5V)

Load Regulation vs. Temperature

Dropout Voltage vs. Load Current(2.5V)

AME8816BEHA VADJ vs. Temperature

Line Transient Response

Load Step 40mA to 1.5A

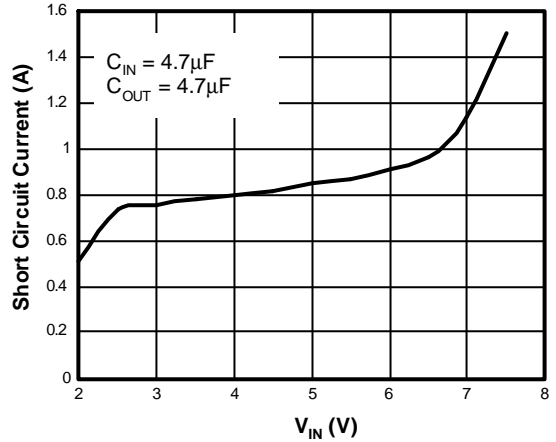
Current Limit Response



Current Limit vs. V_{IN}



Short Circuit Current vs. V_{IN}



Overtemperature Shutdown

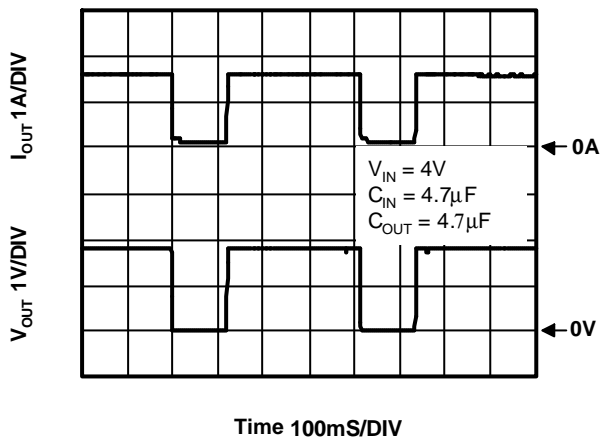

Stability vs. ESR vs. I_{Load}

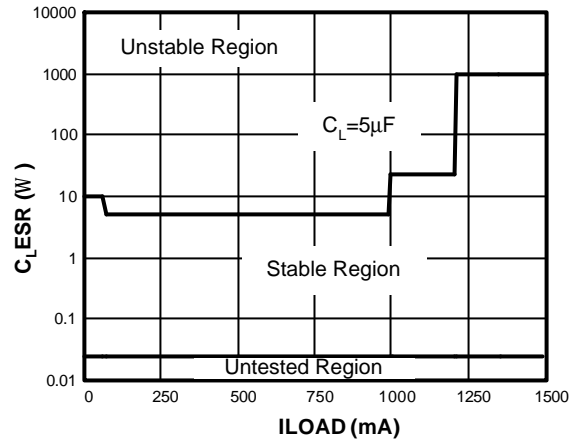

Stability vs. ESR vs. I_{Load}

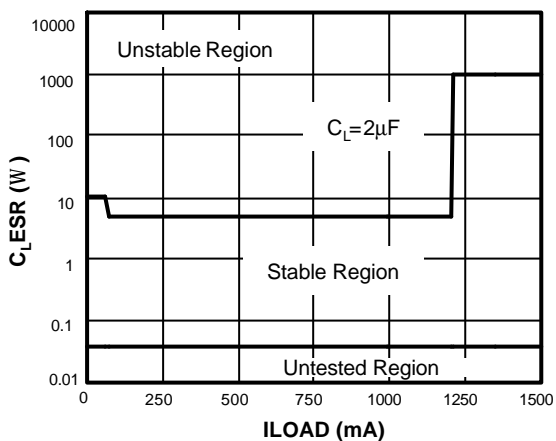

Stability vs. ESR vs. I_{Load}

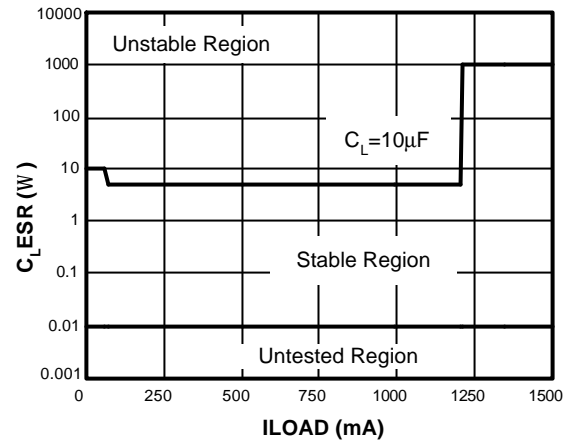



■ External Resistor Divider Table

R1 (K Ohm)	1	2	5	10	20	50	100	200	500	1000
Vout	$R2(\text{kohm})=(1.242 \cdot R1(\text{kohm})) / (Vout-1.242)$									
1.30	21.41	42.83	107.07	214.14	428.28	1070.69				
1.35	11.50	23.00	57.50	115.00	230.00	575.00				
1.40	7.86	15.72	39.30	78.61	157.22	393.04				
1.45	5.97	11.94	29.86	59.71	119.42	298.56	597.55			
1.50	4.81	9.63	24.07	48.14	96.28	240.70	481.68	962.79		
1.55	4.03	8.06	20.16	40.32	80.65	201.62	403.44	806.49		
1.60	3.47	6.94	17.35	34.69	69.39	173.46	347.07	693.85		
1.65	3.04	6.09	15.22	30.44	60.88	152.21	304.52	608.82		
1.70	2.71	5.42	13.56	27.12	54.24	135.59	271.27	542.36		
1.75	2.44	4.89	12.22	24.45	48.90	122.24	244.56	488.98		
1.80	2.23	4.45	11.13	22.26	44.52	111.29	222.64	445.16		
1.85	2.04	4.09	10.21	20.43	40.86	102.14	204.33	408.55		
1.90	1.89	3.78	9.44	18.88	37.75	94.38	188.80	377.51		
1.95	1.75	3.51	8.77	17.54	35.08	87.71	175.46	350.85	877.12	
2.00	1.64	3.28	8.19	16.39	32.77	81.93	163.88	327.70	819.26	
2.05	1.54	3.07	7.69	15.37	30.74	76.86	153.74	307.43	768.56	
2.10	1.45	2.90	7.24	14.48	28.95	72.38	144.78	289.51	723.78	
2.15	1.37	2.74	6.84	13.68	27.36	68.39	136.81	273.57	683.92	
2.20	1.30	2.59	6.48	12.96	25.93	64.82	129.67	259.29	648.23	
2.25	1.23	2.46	6.16	12.32	24.64	61.61	123.23	246.43	616.07	
2.30	1.17	2.35	5.87	11.74	23.48	58.70	117.41	234.78	586.96	
2.35	1.12	2.24	5.60	11.21	22.42	56.05	112.11	224.19	560.47	
2.40	1.07	2.15	5.36	10.73	21.45	53.63	107.27	214.51	536.27	
2.45	1.03	2.06	5.14	10.28	20.56	51.41	102.83	205.63	514.07	
2.50	0.99	1.97	4.94	9.87	19.75	49.36	98.74	197.46	493.64	
2.55	0.95	1.90	4.75	9.50	18.99	47.48	94.97	189.91	474.77	
2.60	0.91	1.83	4.57	9.15	18.29	45.73	91.47	182.92	457.29	914.58
2.65	0.88	1.76	4.41	8.82	17.64	44.11	88.22	176.42	441.05	882.10
2.70	0.85	1.70	4.26	8.52	17.04	42.59	85.19	170.37	425.93	851.85
2.75	0.82	1.65	4.12	8.24	16.47	41.18	82.37	164.72	411.80	823.61
2.80	0.80	1.59	3.99	7.97	15.94	39.86	79.73	159.44	398.59	797.18
2.85	0.77	1.54	3.86	7.72	15.45	38.62	77.25	154.48	386.19	772.39
2.90	0.75	1.50	3.75	7.49	14.98	37.45	74.92	149.82	374.55	749.10
2.95	0.73	1.45	3.64	7.27	14.54	36.36	72.72	145.43	363.58	727.17
3.00	0.71	1.41	3.53	7.06	14.13	35.32	70.65	141.30	353.24	706.48
3.05	0.69	1.37	3.43	6.87	13.74	34.35	68.70	137.39	343.47	686.95
3.10	0.67	1.34	3.34	6.68	13.37	33.42	66.85	133.69	334.23	668.46

■ External Resistor Divider Table (contd.)

R1 (K Ohm)	1	2	5	10	20	50	100	200	500	1000
Vout	$R2(\text{kohm})=(1.242*R1(\text{kohm}))/(\text{Vout}-1.242)$									
3.15	0.65	1.30	3.25	6.51	13.02	32.55	65.09	130.19	325.47	650.94
3.20	0.63	1.27	3.17	6.34	12.69	31.72	63.43	126.86	317.16	634.32
3.25	0.62	1.24	3.09	6.19	12.37	30.93	61.85	123.71	309.26	618.53
3.30	0.60	1.21	3.02	6.03	12.07	30.17	60.35	120.70	301.75	603.50
3.35	0.59	1.18	2.95	5.89	11.78	29.46	58.92	117.84	294.59	589.18
3.40	0.58	1.15	2.88	5.76	11.51	28.78	57.55	115.11	287.77	575.53
3.45	0.56	1.13	2.81	5.63	11.25	28.13	56.25	112.50	281.25	562.50
3.50	0.55	1.10	2.75	5.50	11.00	27.50	55.00	110.01	275.02	550.04
3.55	0.54	1.08	2.69	5.38	10.76	26.91	53.81	107.63	269.06	538.13
3.60	0.53	1.05	2.63	5.27	10.53	26.34	52.67	105.34	263.36	526.72
3.65	0.52	1.03	2.58	5.16	10.32	25.79	51.58	103.16	257.89	515.78
3.70	0.51	1.01	2.53	5.05	10.11	25.26	50.53	101.06	252.64	505.29
3.75	0.50	0.99	2.48	4.95	9.90	24.76	49.52	99.04	247.61	495.22
3.80	0.49	0.97	2.43	4.86	9.71	24.28	48.55	97.11	242.77	485.54
3.85	0.48	0.95	2.38	4.76	9.52	23.81	47.62	95.25	238.11	476.23
3.90	0.47	0.93	2.34	4.67	9.35	23.36	46.73	93.45	233.63	467.27
3.95	0.46	0.92	2.29	4.59	9.17	22.93	45.86	91.73	229.32	458.64
4.00	0.45	0.90	2.25	4.50	9.01	22.52	45.03	90.07	225.16	450.33
4.05	0.44	0.88	2.21	4.42	8.85	22.12	44.23	88.46	221.15	442.31
4.10	0.43	0.87	2.17	4.35	8.69	21.73	43.46	86.91	217.28	434.57
4.15	0.43	0.85	2.14	4.27	8.54	21.35	42.71	85.42	213.55	427.10
4.20	0.42	0.84	2.10	4.20	8.40	20.99	41.99	83.98	209.94	419.88
4.25	0.41	0.83	2.06	4.13	8.26	20.64	41.29	82.58	206.45	412.90
4.30	0.41	0.81	2.03	4.06	8.12	20.31	40.61	81.23	203.07	406.15
4.35	0.40	0.80	2.00	4.00	7.99	19.98	39.96	79.92	199.81	399.61
4.40	0.39	0.79	1.97	3.93	7.87	19.66	39.33	78.66	196.64	393.29
4.45	0.39	0.77	1.94	3.87	7.74	19.36	38.72	77.43	193.58	387.16
4.50	0.38	0.76	1.91	3.81	7.62	19.06	38.12	76.24	190.61	381.22
4.55	0.38	0.75	1.88	3.75	7.51	18.77	37.55	75.09	187.73	375.45
4.60	0.37	0.74	1.85	3.70	7.40	18.49	36.99	73.97	184.93	369.86
4.65	0.36	0.73	1.82	3.64	7.29	18.22	36.44	72.89	182.22	364.44
4.70	0.36	0.72	1.80	3.59	7.18	17.96	35.92	71.83	179.58	359.17
4.75	0.35	0.71	1.77	3.54	7.08	17.70	35.40	70.81	177.02	354.05
4.80	0.35	0.70	1.75	3.49	6.98	17.45	34.91	69.81	174.54	349.07
4.85	0.34	0.69	1.72	3.44	6.88	17.21	34.42	68.85	172.12	344.24
4.90	0.34	0.68	1.70	3.40	6.79	16.98	33.95	67.91	169.76	339.53
4.95	0.33	0.67	1.67	3.35	6.70	16.75	33.50	66.99	167.48	334.95
5.00	0.33	0.66	1.65	3.30	6.61	16.52	33.05	66.10	165.25	330.49

Note: Small load(greater than 2 mA) is necessary as R1 or R2 is larger than 50 K Ohm. Otherwise, outputvoltage probably cannot be pulled down to 0 V on disable mode.

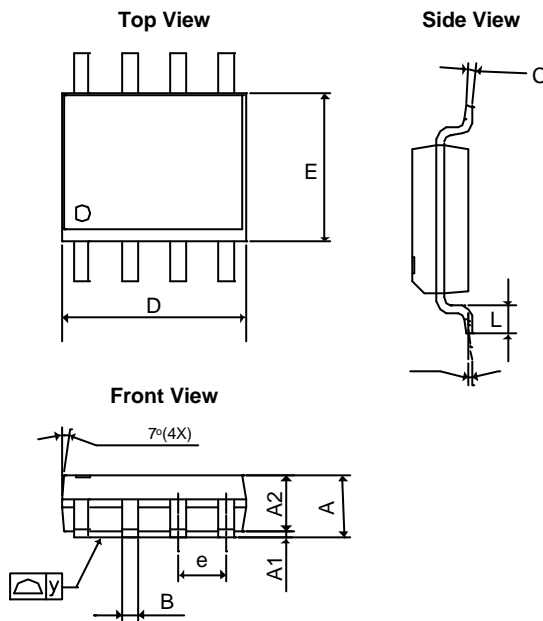
■ Package Dimension
SO-8

SYMBOLS	MILLIMETERS		INCHES	
	MIN	MAX	MIN	MAX
A	1.35	1.75	0.05315	0.0689
A ₁	0.10	0.25	0.00394	0.00984
A ₂	1.473 REF		0.058 REF	
B	0.33	0.51	0.01299	0.02008
C	0.19	0.25	0.00748	0.00984
D	4.80	5.00	0.18898	0.19685
E	3.80	4.00	0.14961	0.15748
e	1.27 BSC		0.050 BSC	
L	0.40	1.27	0.01575	0.05
y	-	0.10	-	0.004
q	0°	8°	0°	8°

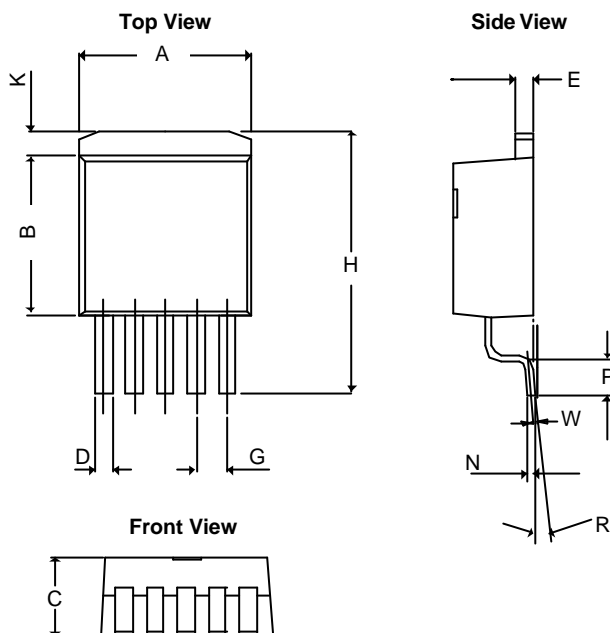
TO-263-5

SYMBOLS	MILLIMETERS		INCHES	
	MIN	MAX	MIN	MAX
A	10.050	10.668	0.396	0.420
B	8.280	9.169	0.326	0.361
C	4.310	4.670	0.170	0.184
D	0.660	0.910	0.026	0.036
E	1.140	1.400	0.045	0.055
G	1.70REF		0.067 REF	
H	14.605	15.875	0.575	0.625
K	1.143	1.680	0.045	0.066
N	0.330	0.580	0.013	0.023
P	2.280	2.800	0.090	0.110
R	0°	8°	0°	8°
W	0.25REF		0.01REF	



www.ame.com.tw
E-Mail: sales@ame.com.tw

Life Support Policy:

These products of AME, Inc. are not authorized for use as critical components in life-support devices or systems, without the express written approval of the president of AME, Inc.

AME, Inc. reserves the right to make changes in the circuitry and specifications of its devices and advises its customers to obtain the latest version of relevant information.

© AME, Inc. , June 2005

Document: 2013-DS8816-H

Corporate Headquarter
AME, Inc.

2F, 302 Rui-Guang Road, Nei-Hu District
Taipei 114, Taiwan .
Tel: 886 2 2627-8687
Fax: 886 2 2659-2989

U.S.A.(Subsidiary)
Analog Microelectronics, Inc.

3100 De La Cruz Blvd., Suite 201
Santa Clara, CA. 95054-2046
Tel : (408) 988-2388
Fax: (408) 988-2489



中发网 WWW.ZFA.CN

全球最大的PDF中文下载站



中发网
www.zfa.cn

PDF 资料下载尽在中发网