



AME, Inc.

## AME8802

300mA CMOS LDO

### General Description

The AME8802 family of positive, linear regulators feature low quiescent current (30 $\mu$ A typ.) with low dropout voltage, making them ideal for battery applications. The space-saving SOT-25 package is attractive for "Pocket" and "Hand Held" applications.

These rugged devices have both Thermal Shutdown, and Current Fold-back to prevent device failure under the "Worst" of operating conditions.

An additional feature is a "Power Good" detector, which pulls low when the output is out of regulation.

The AME8802 is stable with an output capacitance of 2.2 $\mu$ F or greater.

### Features

- Very Low Dropout Voltage
- Guaranteed 300mA Output
- Accurate to within 1.5%
- 30 $\mu$ A Quiescent Current
- Over-Temperature Shutdown
- Current Limiting
- Short Circuit Current Fold-back
- Power Good Output Function
- Power-Saving Shutdown Mode
- Space-Saving SOT-25
- Factory Pre-set Output Voltages
- Low Temperature Coefficient

### Applications

- Instrumentation
- Portable Electronics
- Wireless Devices
- Cordless Phones
- PC Peripherals
- Battery Powered Widgets
- Electronic Scales

### Functional Block Diagram

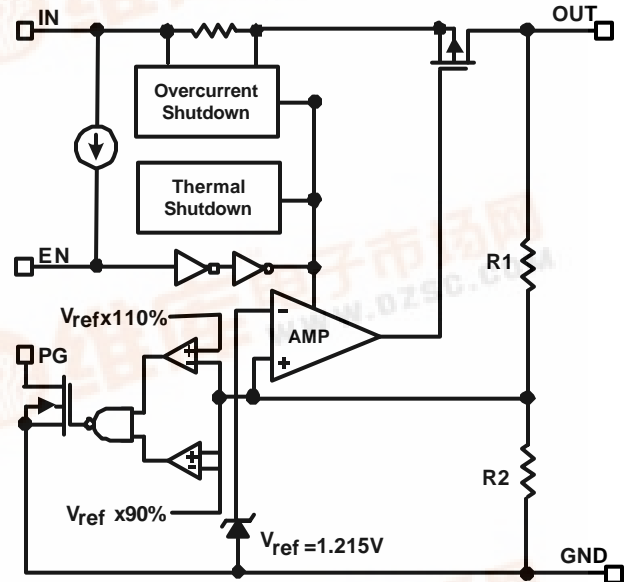

Note: If output voltage specification is lower than 1.215V, Vref will be trimmed to 1.2V

### Typical Application

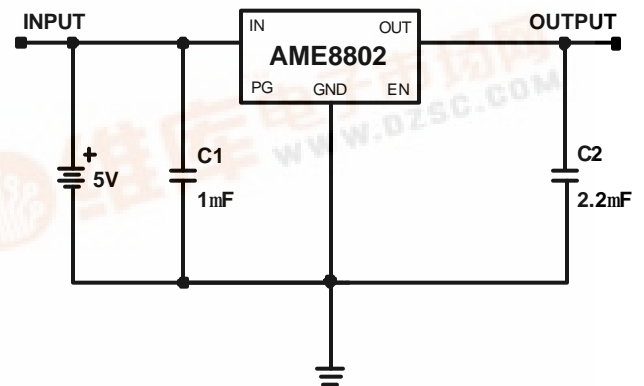



■ Pin Configuration

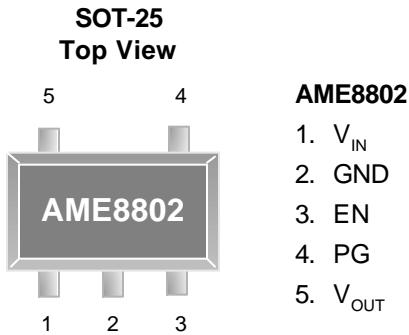

\* Die Attach:  
Conductive Epoxy

■ Ordering Information

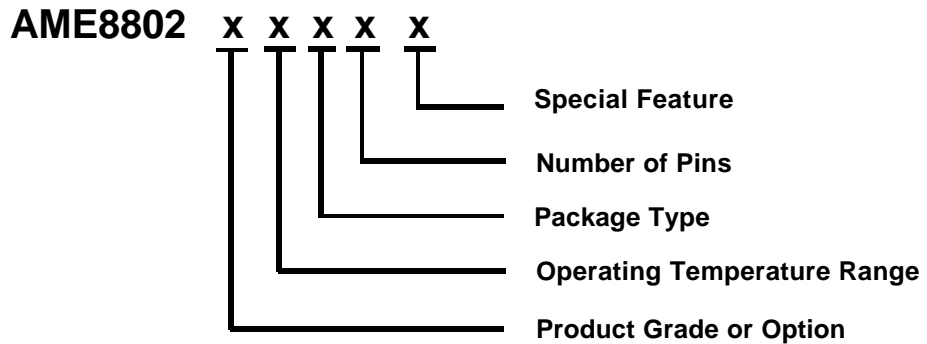

Product Grade or Option	Operating Temperature Range	Package Type	Number of Pins	Special Feature
A: 3.3V    1: 1.3V B: 3.0V    2: 2.0V C: 2.8V    3: 4.2V D: 2.5V    4: 4.0V E: 3.8V F: 3.6V G: 3.5V H: 2.7V I: 3.4V J: 2.85V K: 3.7V L: 1.5V M: 1.8V N: 2.9V O: 3.1V P: 4.1V Q: 4.75V R: 2.65V S: 5.0V T: 1.2V U: 3.2V V: 3.15V W: 2.3V Y: 1.9V Z: 1.7V	E: -40°C to 85°C	E: SOT-2X	V: 5	L: Low Profile Y: Lead Free & Low Profile Z: Lead Free



**AME8802**

**300mA CMOS LDO**

■ **Ordering Information (contd.)**

<b>Part Number</b>	<b>Marking*</b>	<b>Output Voltage</b>	<b>Package</b>	<b>Operating Temp. Range</b>
AME8802AEEV	AAKww	3.3V	SOT-25	- 40°C to + 85°C
AME8802AEEVL	AAKww	3.3V	TSOT-25	- 40°C to + 85°C
AME8802AEEVY	AAKww	3.3V	TSOT-25	- 40°C to + 85°C
AME8802AEEVZ	AAKww	3.3V	SOT-25	- 40°C to + 85°C
AME8802BEEV	AALww	3.0V	SOT-25	- 40°C to + 85°C
AME8802BEEVL	AALww	3.0V	TSOT-25	- 40°C to + 85°C
AME8802BEEVY	AALww	3.0V	TSOT-25	- 40°C to + 85°C
AME8802BEEVZ	AALww	3.0V	SOT-25	- 40°C to + 85°C
AME8802CEEV	AAMww	2.8V	SOT-25	- 40°C to + 85°C
AME8802CEEVL	AAMww	2.8V	TSOT-25	- 40°C to + 85°C
AME8802CEEVY	AAMww	2.8V	TSOT-25	- 40°C to + 85°C
AME8802CEEVZ	AAMww	2.8V	SOT-25	- 40°C to + 85°C
AME8802DEEV	AANww	2.5V	SOT-25	- 40°C to + 85°C
AME8802DEEVL	AANww	2.5V	TSOT-25	- 40°C to + 85°C
AME8802DEEVY	AANww	2.5V	TSOT-25	- 40°C to + 85°C
AME8802DEEVZ	AANww	2.5V	SOT-25	- 40°C to + 85°C
AME8802EEEV	AAOww	3.8V	SOT-25	- 40°C to + 85°C
AME8802EEEVL	AAOww	3.8V	TSOT-25	- 40°C to + 85°C
AME8802EEEVY	AAOww	3.8V	TSOT-25	- 40°C to + 85°C
AME8802EEEVZ	AAOww	3.8V	SOT-25	- 40°C to + 85°C
AME8802FEEV	ABPww	3.6V	SOT-25	- 40°C to + 85°C
AME8802FEEVL	ABPww	3.6V	TSOT-25	- 40°C to + 85°C
AME8802FEEVY	ABPww	3.6V	TSOT-25	- 40°C to + 85°C
AME8802FEEVZ	ABPww	3.6V	SOT-25	- 40°C to + 85°C

Note: ww represents the date code

\* A line on top of the first character represents lead free plating such as AAK

Please consult AME sales office or authorized Rep./Distributor for output voltage and package type availability.



■ Ordering Information (contd.)

Part Number	Marking*	Output Voltage	Package	Operating Temp. Range
AME8802GEEV	ACGww	3.5V	SOT-25	- 40°C to + 85°C
AME8802GEEVL	ACGww	3.5V	TSOT-25	- 40°C to + 85°C
AME8802GEEVY	ACGww	3.5V	TSOT-25	- 40°C to + 85°C
AME8802GEEVZ	ACGww	3.5V	SOT-25	- 40°C to + 85°C
AME8802HEEV	AEHww	2.7V	SOT-25	- 40°C to + 85°C
AME8802HEEVL	AEHww	2.7V	TSOT-25	- 40°C to + 85°C
AME8802HEEVY	AEHww	2.7V	TSOT-25	- 40°C to + 85°C
AME8802HEEVZ	AEHww	2.7V	SOT-25	- 40°C to + 85°C
AME8802IEEV	AEPww	3.4V	SOT-25	- 40°C to + 85°C
AME8802IEEVL	AEPww	3.4V	TSOT-25	- 40°C to + 85°C
AME8802IEEVY	AEPww	3.4V	TSOT-25	- 40°C to + 85°C
AME8802IEEVZ	AEPww	3.4V	SOT-25	- 40°C to + 85°C
AME8802JEEV	AGRww	2.85V	SOT-25	- 40°C to + 85°C
AME8802JEEVL	AGRww	2.85V	TSOT-25	- 40°C to + 85°C
AME8802JEEVY	AGRww	2.85V	TSOT-25	- 40°C to + 85°C
AME8802JEEVZ	AGRww	2.85V	SOT-25	- 40°C to + 85°C
AME8802KEEV	AHTww	3.7V	SOT-25	- 40°C to + 85°C
AME8802KEEVL	AHTww	3.7V	TSOT-25	- 40°C to + 85°C
AME8802KEEVY	AHTww	3.7V	TSOT-25	- 40°C to + 85°C
AME8802KEEVZ	AHTww	3.7V	SOT-25	- 40°C to + 85°C
AME8802LEEV	AJMww	1.5V	SOT-25	- 40°C to + 85°C
AME8802LEEVL	AJMww	1.5V	TSOT-25	- 40°C to + 85°C
AME8802LEEVY	AJMww	1.5V	TSOT-25	- 40°C to + 85°C
AME8802LEEVZ	AJMww	1.5V	SOT-25	- 40°C to + 85°C

**■ Ordering Information**

Part Number	Marking*	Output Voltage	Package	Operating Temp. Range
AME8802MEEV	AJNww	1.8V	SOT-25	- 40°C to + 85°C
AME8802MEEVL	AJNww	1.8V	TSOT-25	- 40°C to + 85°C
AME8802MEEVY	AJNww	1.8V	TSOT-25	- 40°C to + 85°C
AME8802MEEVZ	AJNww	1.8V	SOT-25	- 40°C to + 85°C
AME8802NEEV	AKQww	2.9V	SOT-25	- 40°C to + 85°C
AME8802NEEVL	AKQww	2.9V	TSOT-25	- 40°C to + 85°C
AME8802NEEVY	AKQww	2.9V	TSOT-25	- 40°C to + 85°C
AME8802NEEVZ	AKQww	2.9V	SOT-25	- 40°C to + 85°C
AME8802OEEV	AKRww	3.1V	SOT-25	- 40°C to + 85°C
AME8802OEEVL	AKRww	3.1V	TSOT-25	- 40°C to + 85°C
AME8802OEEVY	AKRww	3.1V	TSOT-25	- 40°C to + 85°C
AME8802OEEVZ	AKRww	3.1V	SOT-25	- 40°C to + 85°C
AME8802SEEV	AQYww	5.0V	SOT-25	- 40°C to + 85°C
AME8802SEEVL	AQYww	5.0V	TSOT-25	- 40°C to + 85°C
AME8802SEEVY	AQYww	5.0V	TSOT-25	- 40°C to + 85°C
AME8802SEEVZ	AQYww	5.0V	SOT-25	- 40°C to + 85°C
AME8802TEEV	ARVww	1.2V	SOT-25	- 40°C to + 85°C
AME8802TEEVL	ARVww	1.2V	TSOT-25	- 40°C to + 85°C
AME8802TEEVY	ARVww	1.2V	TSOT-25	- 40°C to + 85°C
AME8802TEEVZ	ARVww	1.2V	SOT-25	- 40°C to + 85°C
AME8802UEEV	ASDww	3.2V	SOT-25	- 40°C to + 85°C
AME8802UEEVL	ASDww	3.2V	TSOT-25	- 40°C to + 85°C
AME8802UEEVY	ASDww	3.2V	TSOT-25	- 40°C to + 85°C
AME8802UEEVZ	ASDww	3.2V	SOT-25	- 40°C to + 85°C



■ Absolute Maximum Ratings

Parameter	Maximum	Unit
Input Voltage	8	V
Output Current	$P_D / (V_{IN} - V_O)$	mA
Output Voltage	GND - 0.3 to $V_{IN} + 0.3$	V
ESD Classification	B	

Caution: Stress above the listed absolute rating may cause permanent damage to the device

■ Recommended Operating Conditions

Parameter	Rating	Unit
Ambient Temperature Range	- 40 to + 85	°C
Junction Temperature	- 40 to + 125	°C

■ Thermal Information

Parameter	Package	Die Attach	Symbol	Maximum	Unit
Thermal Resistance * (Junction to Case)	SOT-25	Conductive Epoxy	$\theta_{JC}$	81	°C / W
Thermal Resistance (Junction to Ambient)			$\theta_{JA}$	260	
Internal Power Dissipation			$P_D$	400	mW
Maximum Junction Temperature				150	°C
Maximum Lead Temperature (10 Sec)				300	°C

\* Measure  $\theta_{JC}$  on center of molding compound if IC has no tab.



# AME8802

# 300mA CMOS LDO

## ■ Electrical Specifications

TA = 25°C unless otherwise noted

Parameter	Symbol	Test Condition	Min	Typ	Max	Units	
Input Voltage	V <sub>IN</sub>		Note 1		7	V	
Output Voltage Accuracy	V <sub>O</sub>	I <sub>O</sub> =1mA	-1.5		1.5	%	
Dropout Voltage	V <sub>DROPOUT</sub>	I <sub>O</sub> =300mA V <sub>O</sub> =V <sub>O(NOM)</sub> -2.0%	1.2V ≤ V <sub>O(NOM)</sub> ≤ 2.0V	See chart	1300	mV	
			2.0V < V <sub>O(NOM)</sub> ≤ 2.8V		400		
			2.8V < V <sub>O(NOM)</sub>		300		
Output Current	I <sub>O</sub>	V <sub>O</sub> >1.2V	300			mA	
Current Limit	I <sub>LIM</sub>	V <sub>O</sub> >1.2V	300	450		mA	
Short Circuit Current	I <sub>SC</sub>	V <sub>O</sub> <0.8V		150	300	mA	
Quiescent Current	I <sub>Q</sub>	I <sub>O</sub> =0mA		30	50	μA	
Ground Pin Current	I <sub>GND</sub>	I <sub>O</sub> =1mA to 300mA		35		μA	
Line Regulation	REG <sub>LINE</sub>	I <sub>O</sub> =1mA V <sub>IN</sub> =V <sub>O</sub> +1 to V <sub>O</sub> +2	1.2V ≤ V <sub>O</sub> ≤ 1.4V	-0.2		0.2	%
			1.4V < V <sub>O</sub> ≤ 2.0V	-0.15		0.15	
			2.0V < V <sub>O</sub> < 4.0V	-0.1	0.02	0.1	
			4.0V ≤ V <sub>O</sub>	-0.4	0.2	0.4	
Load Regulation	REG <sub>LOAD</sub>	I <sub>O</sub> =1mA to 300mA	-1	0.2	1	%	
Over Temperature Shutdown	OTS			150		°C	
Over Temperature Hysteresis	OTH			30		°C	
V <sub>O</sub> Temperature Coefficient	TC			30		ppm/°C	
Power Supply Rejection	PSRR	I <sub>O</sub> =100mA C <sub>O</sub> =2.2μF	f = 100Hz		60	dB	
			f = 1kHz		50		
			f = 10kHz		20		
Output Voltage Noise	eN	f=10Hz to 100kHz I <sub>O</sub> =10mA			30	μVrms	
EN Input Threshold	V <sub>EH</sub>	V <sub>IN</sub> =2.7V to 7V	2.0		V <sub>in</sub>	V	
	V <sub>EL</sub>	V <sub>IN</sub> =2.7V to 7V	0		0.4	V	
EN Input Bias Current	I <sub>EH</sub>	V <sub>EN</sub> =V <sub>IN</sub> , V <sub>IN</sub> =2.7V to 7V			0.1	μA	
	I <sub>EL</sub>	V <sub>EN</sub> =0V, V <sub>IN</sub> =2.7V to 7V			0.5	μA	
Shutdown Supply Current	I <sub>SD</sub>	V <sub>IN</sub> =5V, V <sub>O</sub> =0V, V <sub>EN</sub> <V <sub>EL</sub>		0.5	1	μA	
Shutdown Output Voltage	V <sub>O,SD</sub>	I <sub>O</sub> =0.4mA, V <sub>EN</sub> <V <sub>EL</sub>	0		0.4	V	
Output Under Voltage	V <sub>UV</sub>	2.5V ≤ V <sub>O(NOM)</sub> ≤ 5.0V			85	%V <sub>O(NOM)</sub>	
		1.2V ≤ V <sub>O(NOM)</sub> < 2.5V			75		
Output Over Voltage	V <sub>OV</sub>	2.5V ≤ V <sub>O(NOM)</sub> ≤ 5.0V	115			%V <sub>O(NOM)</sub>	
		1.2V ≤ V <sub>O(NOM)</sub> < 2.5V	125				
PG Leakage Current	I <sub>LC</sub>	V <sub>PG</sub> =7V			1	μA	
PG Voltage Rating	V <sub>PG</sub>	V <sub>O</sub> in regulation			7	V	
PG Voltage Low	V <sub>OL</sub>	I <sub>SINK</sub> =0.4mA			0.4	V	

Note1: V<sub>UV</sub> = V<sub>UV</sub> + V<sub>UV</sub>



## ■ Detailed Description

The AME8802 family of CMOS regulators contain a PMOS pass transistor, voltage reference, error amplifier, over-current protection, thermal shutdown, and power good function.

The P-channel pass transistor receives data from the error amplifier, over-current shutdown, and thermal protection circuits. During normal operation, the error amplifier compares the output voltage to a precision reference. Over-current and Thermal shutdown circuits become active when the junction temperature exceeds 150°C, or the current exceeds 300mA. During thermal shutdown, the output voltage remains low. Normal operation is restored when the junction temperature drops below 120°C.

The AME8802 switches from voltage mode to current mode when the load exceeds the rated output current. This prevents over-stress. The AME8802 also incorporates current foldback to reduce power dissipation when the output is short circuited. This feature becomes active when the output drops below 0.8volts, and reduces the current flow by 65%. Full current is restored when the voltage exceeds 0.8 volts.

## ■ External Capacitors

The AME8802 is stable with an output capacitor to ground of 2.2 $\mu$ F or greater. Ceramic capacitors have the lowest ESR, and will offer the best AC performance. Conversely, Aluminum Electrolytic capacitors exhibit the highest ESR, resulting in the poorest AC response. Unfortunately, large value ceramic capacitors are comparatively expensive. One option is to parallel a 0.1 $\mu$ F ceramic capacitor with a 10 $\mu$ F Aluminum Electrolytic. The benefit is low ESR, high capacitance, and low overall cost.

A second capacitor is recommended between the input and ground to stabilize  $V_{in}$ . The input capacitor should be at least 0.1 $\mu$ F to have a beneficial effect.

All capacitors should be placed in close proximity to the pins. A "Quiet" ground termination is desirable. This can be achieved with a "Star" connection.

## ■ Enable

The Enable pin normally floats high. When actively, pulled low, the PMOS pass transistor shuts off, and all internal circuits are powered down. In this state, the quiescent current is less than 1 $\mu$ A. This pin behaves much like an electronic switch.

## ■ Power Good

The AME8802 includes the Power Good feature. When the output is not within  $\pm 5\%$  of the specified voltage, it pulls low. This can occur under the following conditions:

- 1) Input Voltage too low.
- 2) During Over-Temperature.
- 3) During Over-Current.
- 4) If output is pulled up.

*(Note: PG pin is an open-drain output.)*

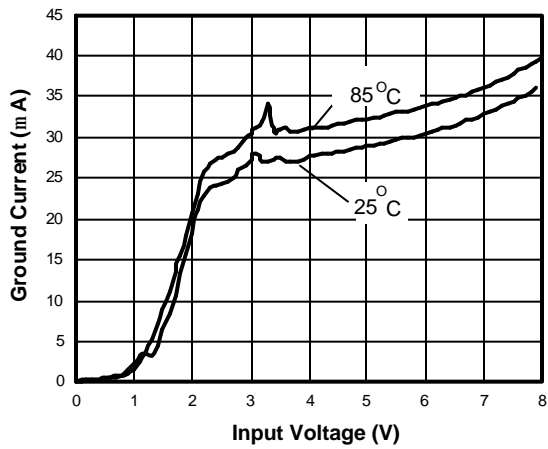
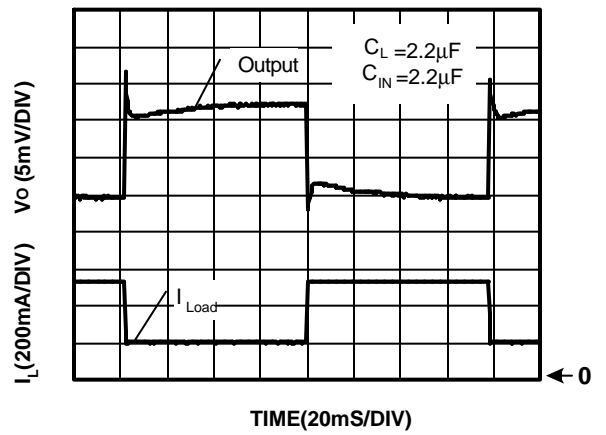
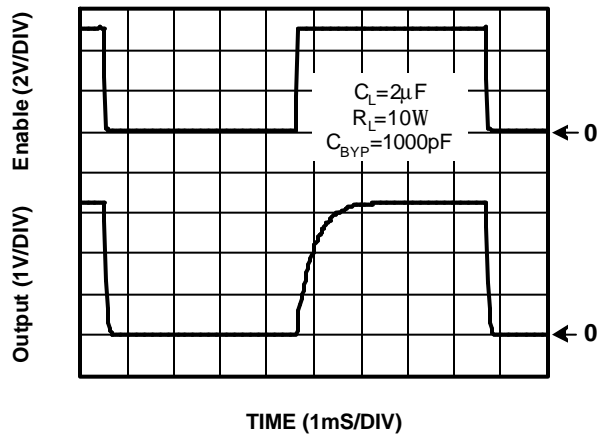
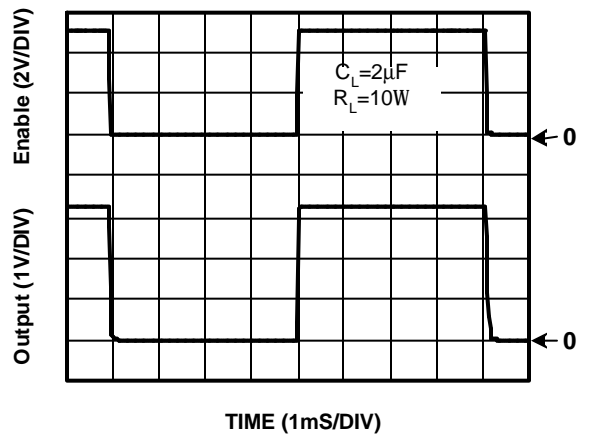
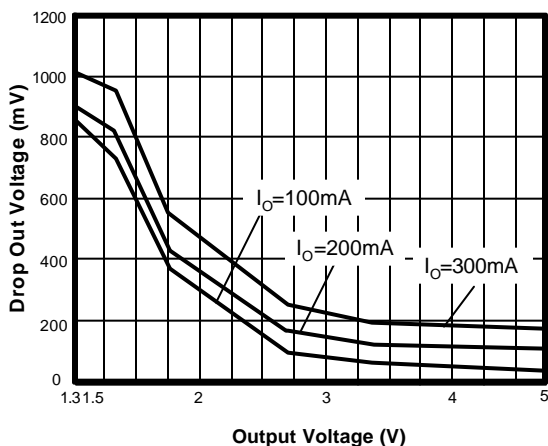
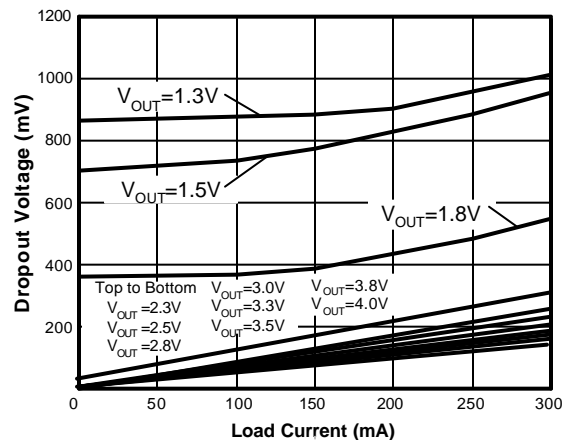

**Ground Current vs. Input Voltage**

**Load Step (1mA-300mA)**

**Chip Enable Transient Response**

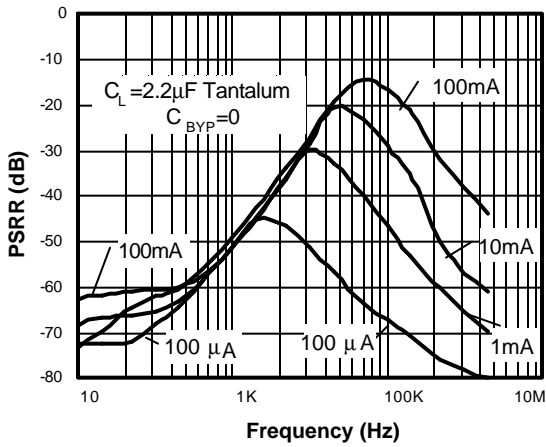
**Chip Enable Transient Response**

**Drop Out Voltage vs. Output Voltage**

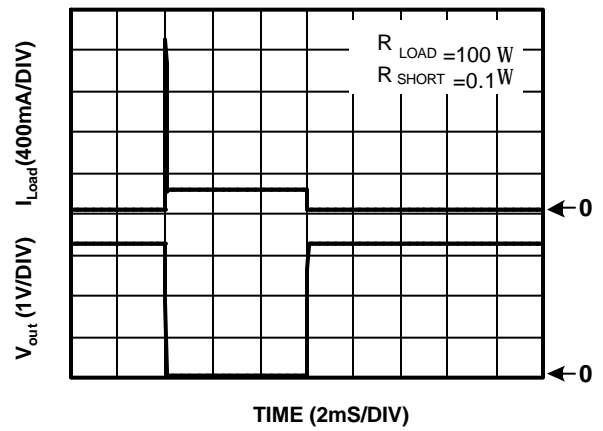
**Drop Out Voltage vs. Load Current**



Power Supply Rejection Ratio



Short Circuit Response



Overtemperature Shutdown

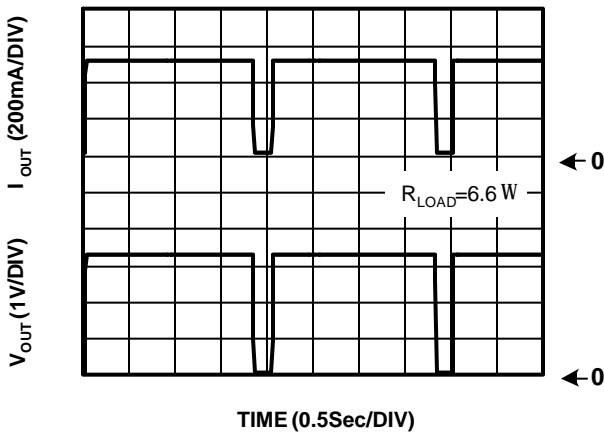

Current Limit Response

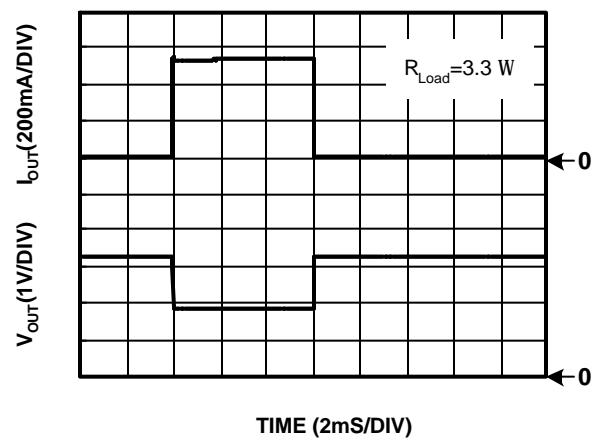

Noise Measurement

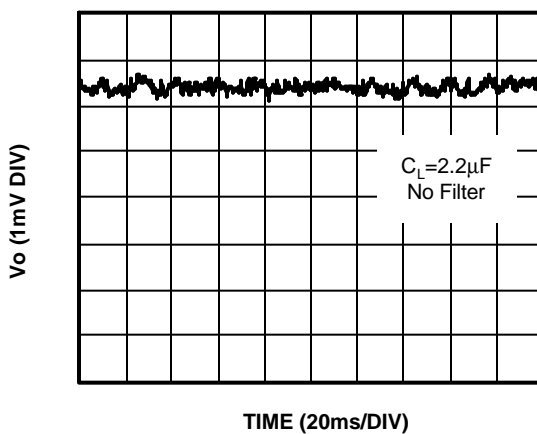

Line Transient Response

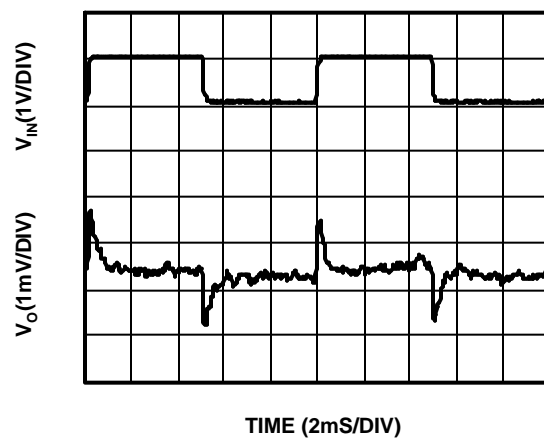

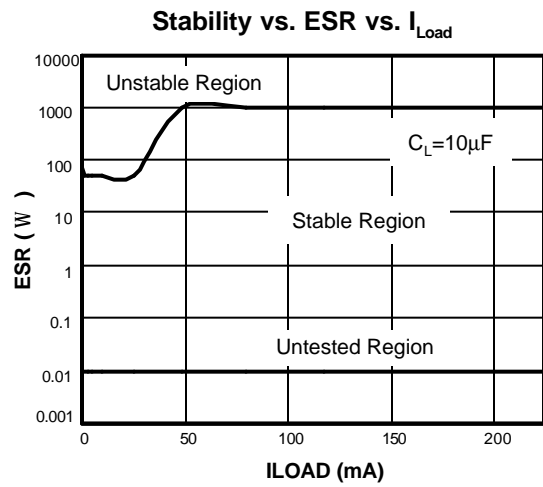
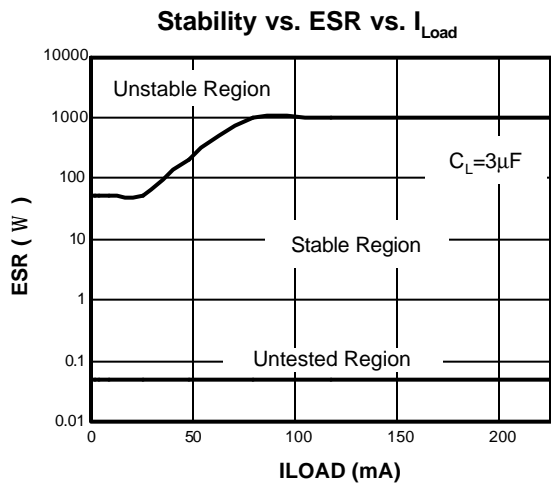
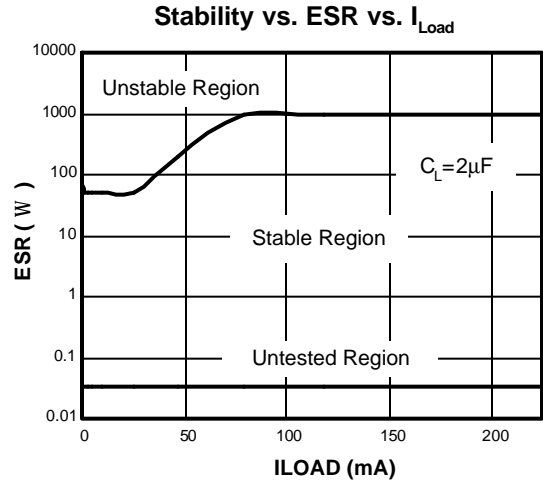
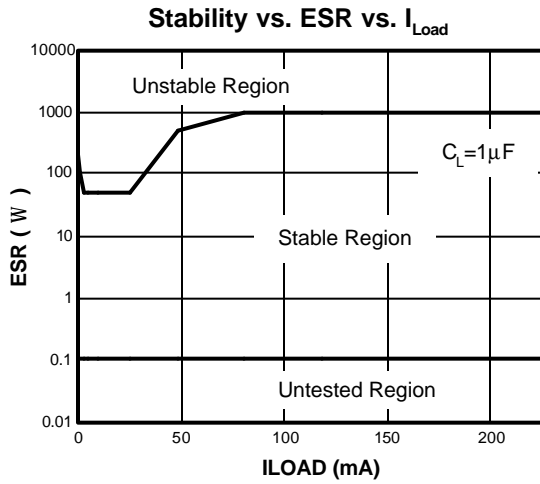

**Safe Operating Area**

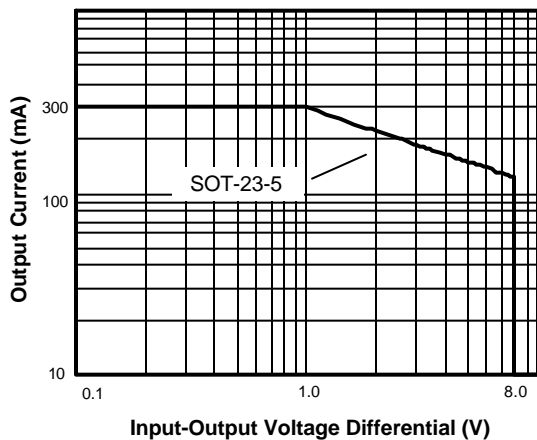



Quiescent Current vs. Temp.

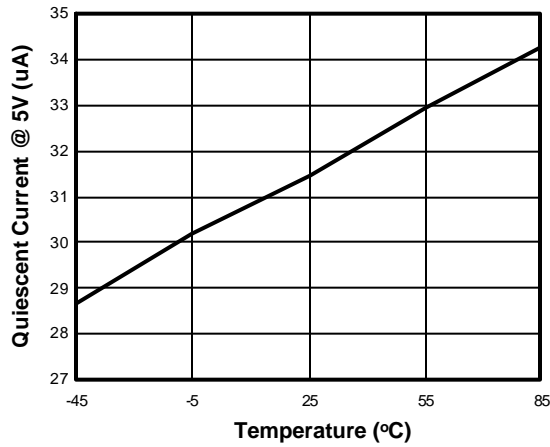

Load Regulation vs. Temp.

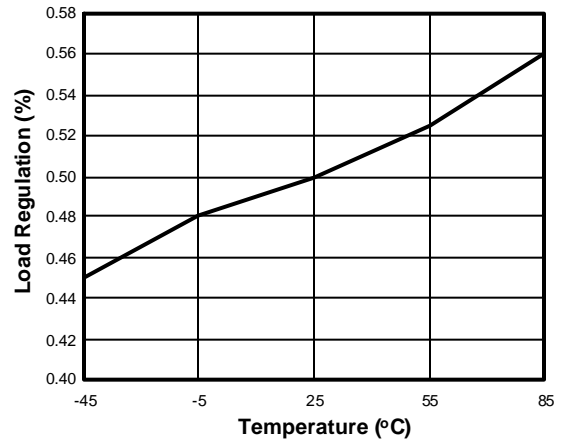

Shut Down Current vs. Temp.

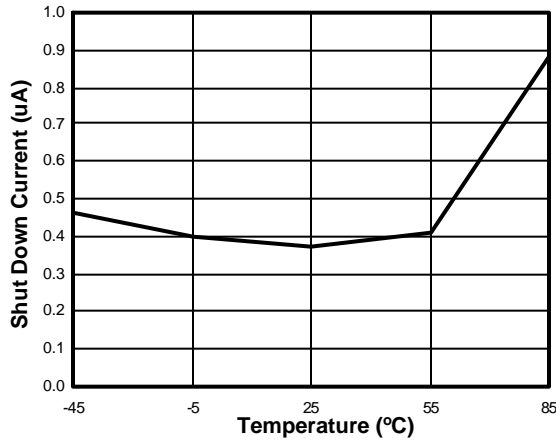

EN pin LO bias Current vs. Temp.

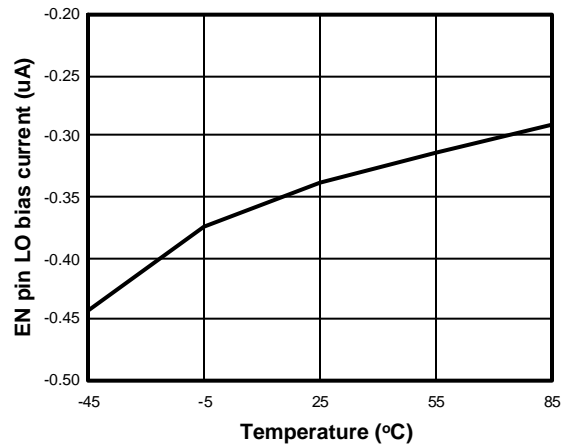

Dropout Voltage vs. Temp.

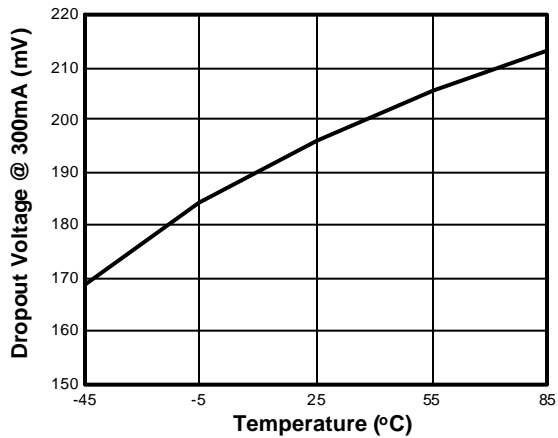

PG VOL vs. Temp.

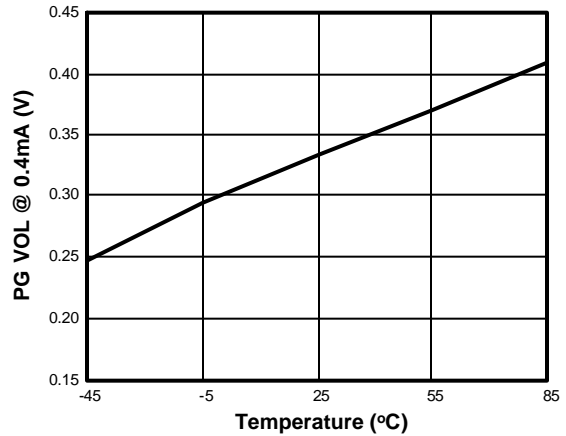

**■ Date Code Rule**

Marking			Date Code		Year
A	A	A	W	W	xxx0
A	A	A	W	<u>W</u>	xxx1
A	A	A	<u>W</u>	W	xxx2
A	A	A	<u>W</u>	<u>W</u>	xxx3
A	A	<u>A</u>	W	W	xxx4
A	A	<u>A</u>	W	<u>W</u>	xxx5
A	A	<u>A</u>	<u>W</u>	W	xxx6
A	A	<u>A</u>	<u>W</u>	<u>W</u>	xxx7
A	<u>A</u>	A	W	W	xxx8
A	<u>A</u>	A	W	<u>W</u>	xxx9

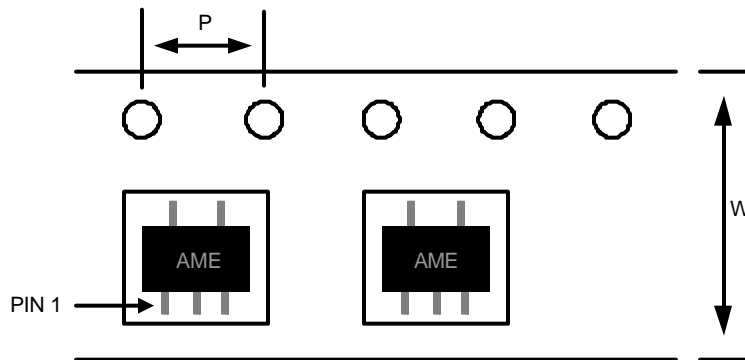
**■ Tape and Reel Dimension**
**SOT-25**

**Carrier Tape, Number of Components Per Reel and Reel Size**

Package	Carrier Width (W)	Pitch (P)	Part Per Full Reel	Reel Size
SOT-25	8.0±0.1 mm	4.0±0.1 mm	3000pcs	180±1 mm

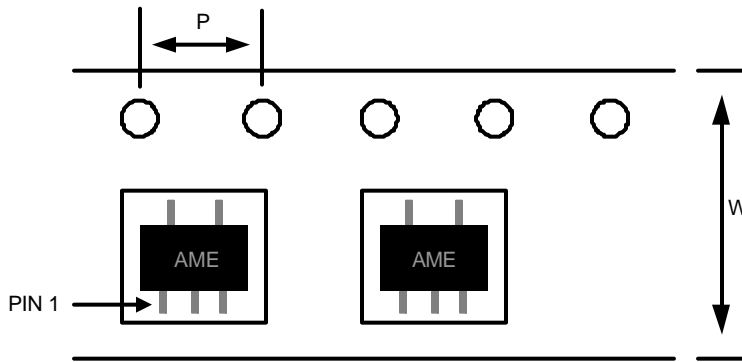

■ Tape and Reel Dimension

TSOT-25



Carrier Tape, Number of Components Per Reel and Reel Size

Package	Carrier Width (W)	Pitch (P)	Part Per Full Reel	Reel Size
TSOT-25	8.0±0.1 mm	4.0±0.1 mm	3000pcs	180±1 mm

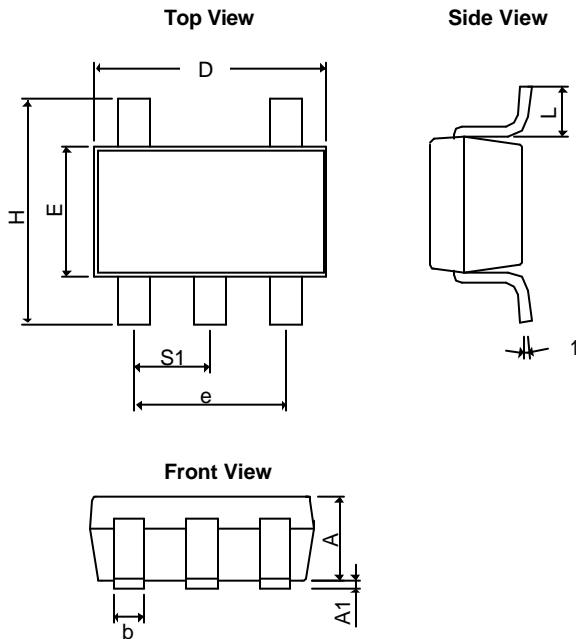
**■ Package Dimension**
**SOT-25**

SYMBOLS	MILLIMETERS		INCHES	
	MIN	MAX	MIN	MAX
A	1.20REF		0.0472REF	
A <sub>1</sub>	0.00	0.15	0.0000	0.0059
b	0.30	0.55	0.0118	0.0217
D	2.70	3.10	0.1063	0.1220
E	1.40	1.80	0.0551	0.0709
e	1.90 BSC		0.07480 BSC	
H	2.60	3.00	0.10236	0.11811
L	0.37BSC		0.0146BSC	
q1	0°	10°	0°	10°
S <sub>1</sub>	0.95BSC		0.0374BSC	

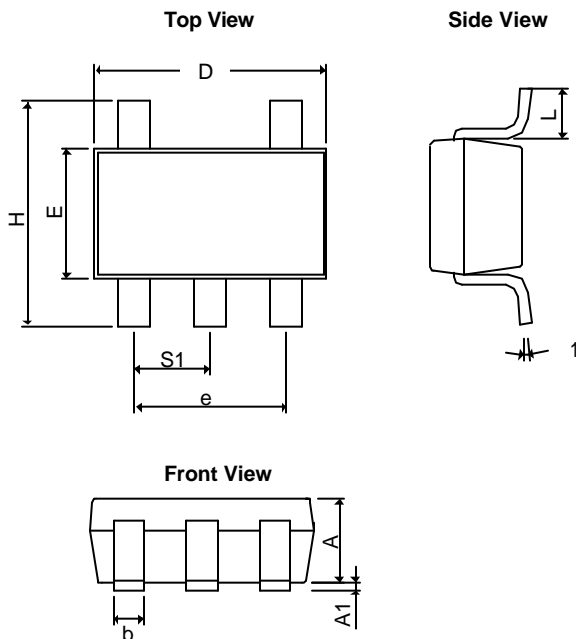
**TSOT-25**

SYMBOLS	MILLIMETERS		INCHES	
	MIN	MAX	MIN	MAX
A+A <sub>1</sub>	0.90	1.25	0.0354	0.0492
b	0.30	0.50	0.0118	0.0197
c	0.09	0.25	0.0035	0.0098
D	2.70	3.10	0.1063	0.1220
E	1.40	1.80	0.0551	0.0709
e	1.90 BSC		0.07480 BSC	
H	2.40	3.00	0.09449	0.11811
L	0.35BSC		0.0138BSC	
q1	0°	10°	0°	10°
S <sub>1</sub>	0.95BSC		0.0374BSC	



**www.ame.com.tw**  
**E-Mail: sales@ame.com.tw**

Life Support Policy:

These products of AME, Inc. are not authorized for use as critical components in life-support devices or systems, without the express written approval of the president of AME, Inc.

AME, Inc. reserves the right to make changes in the circuitry and specifications of its devices and advises its customers to obtain the latest version of relevant information.

© AME, Inc. , November 2005

Document: 2006/2095-DS8802-J

**Corporate Headquarter**  
**AME, Inc.**

2F, 302 Rui-Guang Road, Nei-Hu District  
Taipei 114, Taiwan.  
Tel: 886 2 2627-8687  
Fax: 886 2 2659-2989

**U.S.A.(Subsidiary)**  
**Analog Microelectronics, Inc.**

3100 De La Cruz Blvd., Suite 201  
Santa Clara, CA. 95054-2046  
Tel : (408) 988-2388  
Fax: (408) 988-2489







中发网 WWW.ZFA.CN

全球最大的PDF中文下载站



**中发网**  
www.zfa.cn

**PDF 资料下载尽在中发网**