



AME8750

Low-Dropout 150mA / 150mA Dual CMOS Regulator

General Description

The AME8750 dual, low dropout, linear regulators operate from Higher $V_{OUT} + V_{DROPOUT}$ to 5.5V input and deliver up to 150mA / 150mA output current each. It has a bypass pin option allows users to decouple the bandgap reference for reducing the output noise. Low dropout voltage and low quiescent current (70 μ A typ.) make them ideal for battery applications.

The AME8750 is available with a wide variety of voltage options as standard and can be trimmed to 1.5% accuracy.

For protection purpose, AME8750 has both thermal shutdown and current fold-back to prevent device failure under the "worst" of operating conditions.

Features

- Very Low Dropout Voltage
- Guaranteed 150mA / 150mA Each Output
- Accurate to Within 1.5% For Both Outputs
- Typical 70 μ A Quiescent Current
- Over-Temperature Shutdown
- Current Limiting
- Short Circuit Current Fold-back
- Noise Reduction Bypass Cap
- Power-Saving Shutdown Mode
- All AME's Lead Free Product Meet RoHS Standards

Applications

- Cellular Phones
- Palm / Notebook
- Battery Power Equipment
- Handheld Instruments

Functional Block Diagram

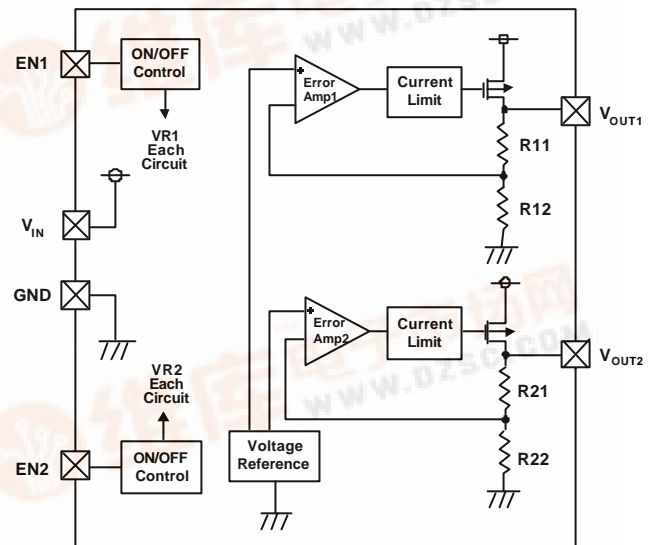

Typical Applications

Fixed Version

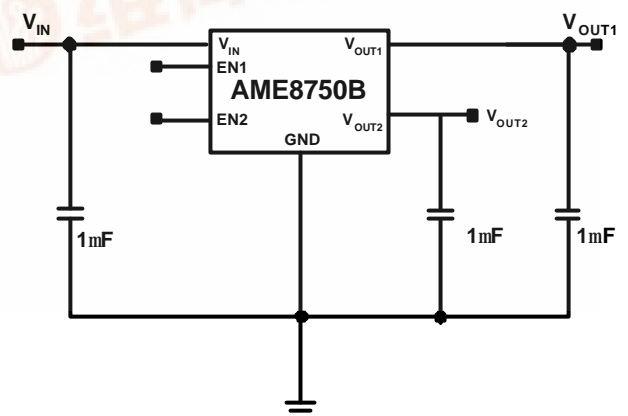
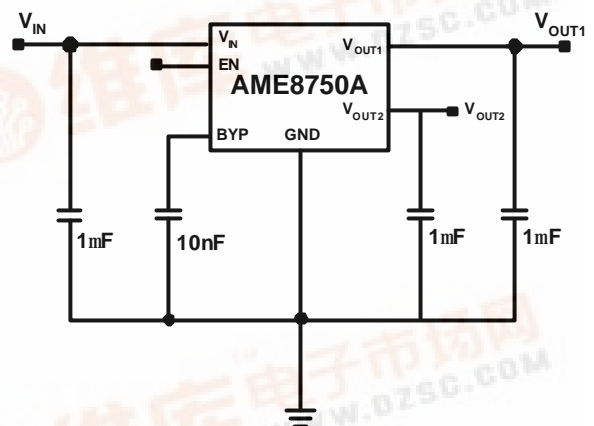

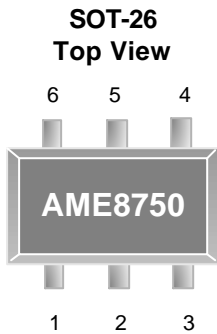
■ Pin Configuration

AME 8750AEEY

1. V_{OUT2}
2. GND
3. BYP
4. EN
5. V_{IN}
6. V_{OUT1}

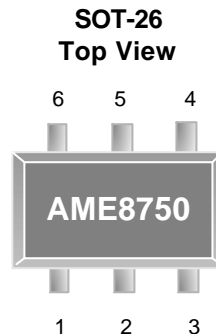
* **Die Attach:**
Conductive Epoxy

AME 8750BEEY

1. V_{OUT2}
2. GND
3. EN1
4. EN2
5. V_{IN}
6. V_{OUT1}

* **Die Attach:**
Conductive Epoxy

■ Pin Description

Pin Number		Pin Name	Description
AME8750A	AME8750B		
1	1	V_{OUT2}	Regulator 2 Output. Sources up to 150mA continuous current. Bypass with a $1\mu\text{F}$ ($< 0.5\Omega$ typ ESR) capacitor to GND.
2	2	GND	Ground. This pin also functions as heatsink. Solder to a large pad or the circuit-board ground plane to maximize thermal dissipation.
3	N/A	BYP	Reference Noise Bypass. Bypass with a low leakage 10nF ceramic capacitor for reduced noise at both outputs.
N/A	3	EN1	Shutdown 1 Input. A logic low shuts down regulator 1. If EN1 and EN2 are both low, both regulators and the reference turn off. If either EN1 and EN2 is a logic high, the reference is on. Connect to V_{IN} for normal operation.
4	N/A	EN	Shutdown Input. A logic low shuts down both regulators. Connect to V_{IN} for normal operation.
N/A	4	EN2	Shutdown 2 Input. A logic low shuts down regulator 2. If EN1 and EN2 are both low, both regulators and the reference turn off. If either EN1 and EN2 is a logic high, the reference is on. Connect to V_{IN} for normal operation.
5	5	V_{IN}	Regulator Input. Supply voltage can range from Higher $V_{OUT}+V_{DROPOUT}$ to 5.5V. This input also supplies the on-chip reference. Bypass with $1\mu\text{F}$ to GND.
6	6	V_{OUT1}	Regulator 1 Output. Sources up to 150mA continuous current. Bypass with a $1\mu\text{F}$ ($< 0.5\Omega$ typ ESR) capacitor to GND.



■ Ordering Information (contd.)

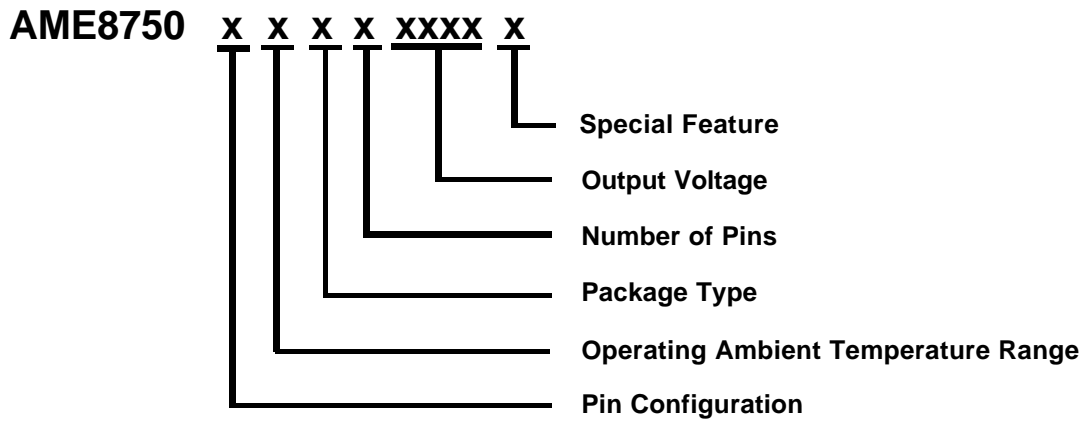

Pin Configuration	Operating Ambient Temperature Range	Package Type	Number of Pins	Output Voltage (Both LDOs)	Special Feature
A (SOT-26) 1. V _{OUT2} 2. GND 3. BYP 4. EN 5. V _{IN} 6. V _{OUT1}	E: -40°C to +85°C	E: SOT-2X	Y: 6	1825: V _{OUT1} =1.8V V _{OUT2} =2.5V 1828: V _{OUT1} =1.8V V _{OUT2} =2.8V	Y: Lead free & Low profile Z: Lead free
B (SOT-26) 1. V _{OUT2} 2. GND 3. EN2 4. EN1 5. V _{IN} 6. V _{OUT1}					

■ Ordering Information

Part Number	Marking*	Output Voltage	Package	Operating Ambient Temperature Range
AME8750AEEY1828Z	BCKww	V _{OUT1} =1.8V V _{OUT2} =2.8V	SOT-26	- 40°C to + 85°C
AME8750AEEY1828Y	BCKww	V _{OUT1} =1.8V V _{OUT2} =2.8V	TSOT-26	- 40°C to + 85°C
AME8750BEEY1828Z	BCJww	V _{OUT1} =1.8V V _{OUT2} =2.8V	SOT-26	- 40°C to + 85°C
AME8750BEEY1828Y	BCJww	V _{OUT1} =1.8V V _{OUT2} =2.8V	TSOT-26	- 40°C to + 85°C
AME8750BEEY1825Z	BBHww	V _{OUT1} =1.8V V _{OUT2} =2.5V	SOT-26	- 40°C to + 85°C
AME8750BEEY1825Y	BBHww	V _{OUT1} =1.8V V _{OUT2} =2.5V	TSOT-26	- 40°C to + 85°C

Note:ww represents date code and pls refer to Date Code Rule before Package Dimension.

* A line on top of the first letter represents lead free plating such as BCKww.

Please consult AME sales office or authorized Rep./Distributor for voltage accuracy and package type availability.



AME8750

**Low-Dropout
150mA / 150mA Dual CMOS Regulator**

■ Absolute Maximum Ratings

Parameter	Maximum	Unit
Input Voltage	6	V
Output Current	$P_D/2V_{IN}-(V_{OUT1}+V_{OUT2})$	mA
Output Voltage	GND-0.3 to $V_{IN}+0.3$	V
ESD Classification	B*	

Caution: Stress above the listed absolute maximum rating may cause permanent damage to the device.

* HBM B: 2000V~3999V

■ Recommended Operating Conditions

Parameter	Symbol	Rating	Unit
Ambient Temperature Range	T_A	-40 to +85	°C
Junction Temperature Range	T_J	-40 to +125	°C

■ Thermal Information

Parameter	Package	Die Attach	Symbol	Maximum	Unit
Thermal Resistance* (Junction to Case)	SOT-26	Conductive Epoxy	θ_{JC}	81	°C / W
Thermal Resistance (Junction to Ambient)			θ_{JA}	260	
Internal Power Dissipation			P_D	400	mW
Maximum Junction Temperature				150	°C
Solder Iron (10 Sec)**				350	°C

* Measure θ_{JC} on center of molding compound if IC has no tab.

** MIL-STD-202G 210F

■ Electrical Specifications

Unless specified: $T_J=25^{\circ}\text{C}$, $V_{IN}=\text{Higher } V_{OUT}+1\text{V}$, $I_{OUT1}=I_{OUT2}=1\text{mA}$, $C_{IN}=C_{OUT}=1.0\mu\text{F}$, $V_{EN1}=V_{EN2}=V_{IN}$
 Typical values are at $T_J=25^{\circ}\text{C}$

Parameter	Symbol	Test Condition	Min	Typ	Max	Units	
IN							
Input Supply Voltage	V_{IN}		Note1		5.5	V	
Quiescent Current	I_Q			70	160	μA	
OUT1, OUT2							
Output Voltage	V_O	$I_{OUT}=1\text{mA}$		-1.5	V_{OUT}	1.5	
		$0\text{mA}<I_{OUT}<=150\text{mA}$ $V_{OUT}+1\text{V}<V_{IN}<5.5\text{V}$	$T_J=-40^{\circ}\text{C}$ to $+125^{\circ}\text{C}$	-2		2	%
Line Regulation	REG_{LINE}	$V_{OUT}+1\text{V}<V_{IN}<5.5\text{V}$, $I_{OUT}=1\text{mA}$	$T_J=25^{\circ}\text{C}$	-0.2		0.2	
			$T_J=-40^{\circ}\text{C}$ to $+125^{\circ}\text{C}$	-0.25		0.25	%/V
Load Regulation	REG_{LOAD}	$1\text{mA}<I_{OUT}$	$T_J=-40^{\circ}\text{C}$ to $+125^{\circ}\text{C}$	-0.005	+0.0025	0.005	%/mA
Dropout Voltage	V_{DROP}	$I_{OUT1}=I_{OUT2}=150\text{mA}$ $(V_O=V_{O(\text{NOM})}-2\%),$ $V_{O(\text{NOM})}<2.5\text{V}$	$T_J=-40^{\circ}\text{C}$ to $+125^{\circ}\text{C}$			350	mV
		$I_{OUT1}=I_{OUT2}=150\text{mA}$ $(V_O=V_{O(\text{NOM})}-2\%),$ $V_{O(\text{NOM})}\geq 2.5\text{V}$				300	mV
Current Limit	I_{LIM}			180		600	mA
Short Circuit Current	I_{SC}				200	350	
Ripple Rejection	PSRR	$f=100\text{Hz}$, $C_{\text{BYP}}=10\text{nF}$, $I_{OUT}=1\text{mA}$			55		dB
		$f=1\text{kHz}$, $C_{\text{BYP}}=10\text{nF}$, $I_{OUT}=1\text{mA}$			55		
		$f=10\text{kHz}$, $C_{\text{BYP}}=10\text{nF}$, $I_{OUT}=1\text{mA}$			48		
Output Voltage Noise	e_n	$f=1\text{kHz}$ to 100kHz $C_{\text{BYP}}=10\text{nF}$, $C_{OUT}=1\mu\text{F}$			550		μVRMS
		$f=1\text{kHz}$ to 100kHz $C_{\text{BYP}}=10\text{nF}$, $C_{OUT}=1\mu\text{F}$			5.5		$\mu\text{V}/\text{Hz}$
EN1, EN2							
Enable Input Threshold	V_{EH}	$V_{IN}=2.4\text{V}$ to 5.5V	$T_J=-40^{\circ}\text{C}$ to $+125^{\circ}\text{C}$	2.4			V
	V_{EL}	$V_{IN}=2.4\text{V}$ to 5.5V				0.4	V
EN Input Bias Current	I_{EL}	$V_{IN}=5.0\text{V}$	EN=0V	-1	0.5	1	μA
	I_{EH}		EN=5V				
Shutdown Current	I_{SHDN}	$V_{IN}=5.0\text{V}$, EN1=EN2=0V			0.3	1	
BYP							
Start-Up Rise Time		$C_{\text{BYP}}=10\text{nF}$			1.25		ms
Over Temperature Protection							
Over Temperature Shutdown	OTS				150		$^{\circ}\text{C}$
Over Temperature Hysteresis	OTH				20		$^{\circ}\text{C}$

Note1: $V_{\text{IN}(\text{min})}=\text{Higher } V_{\text{OUT}}+V_{\text{Dropout}}$

■ Detailed Description

The AME8750 is low-dropout, low quiescent-current linear regulator designed primarily for battery-powered applications. These parts are available with preset output voltage ranging from 1.8V to 3.3V, and the parts can supply loads up to 150mA.

Shutdown

AME8750A

The AME8750A has a single shutdown control input (EN). Drive EN low to shut down both outputs, reducing supply current to 0.3µA. Connect EN to a logic-high, or IN, for normal operation.

AME8750B

The AME8750B has independent shutdown control inputs (EN1 and EN2). Drive EN1 low to shutdown V_{OUT1} . Drive EN2 low to shut down V_{OUT2} . Drive both EN1 and EN2 low to shut down the entire chip, reducing supply current to 0.3mA. Connect both EN1 and EN2 to a logic-high, or IN, for normal operation.

Internal P-Channel Pass Transistor

The AME8750A/AME8750B feature two 1Ω P-Channel MOSFET pass transistors. A P-Channel MOSFET provides several advantages over similar designs using PNP pass transistors, including longer battery life. It requires no base drive, which reduces quiescent current significantly. The AME8750A/AME8750B only consume 70µA of quiescent current whether in dropout, light-load, or heavy-load applications.

Current Limit

The AME8750A/8750B contain two independent current limiters, one for each regulator, which monitor and control the pass transistor's gate voltage, limiting the guaranteed maximum output current to 150mA minimum. The output can be shorted to ground for an indefinite time without damaging the part.

Thermal-Overload Protection

Thermal-overload protection limits total power dissipation in the AME8750A/AME8750B. When the junction temperature exceeds $T_J=150^{\circ}\text{C}$, the thermal sensor signals the shutdown logic, turning off the pass transistor and allowing the IC to cool.

■ Application Information

Capacitor Selection and Regulator Stability

Use a 1µF capacitor on the AME8750A/ AME8750B input and a 1µF capacitor on the outputs. Larger input capacitor values and lower ESRs provide better supply noise rejection and line transient response.

PSRR and Operation from Sources Other than Batteries

The AME8750A/AME8750B are designed to deliver low dropout voltages and low quiescent currents in battery-powered systems. Power-supply rejection is 54dB at low frequencies.

(See the PSRR vs. Frequency graph)

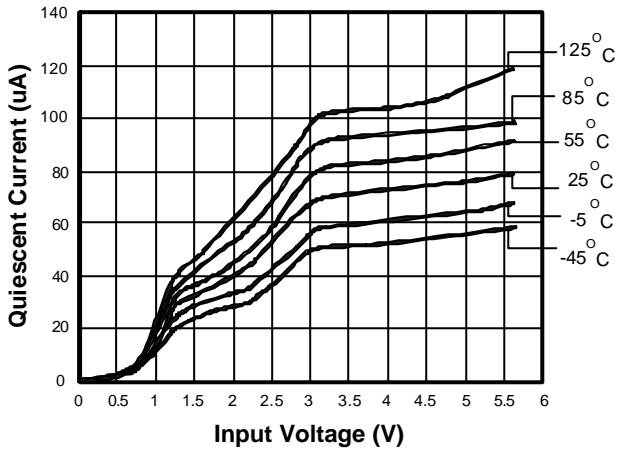
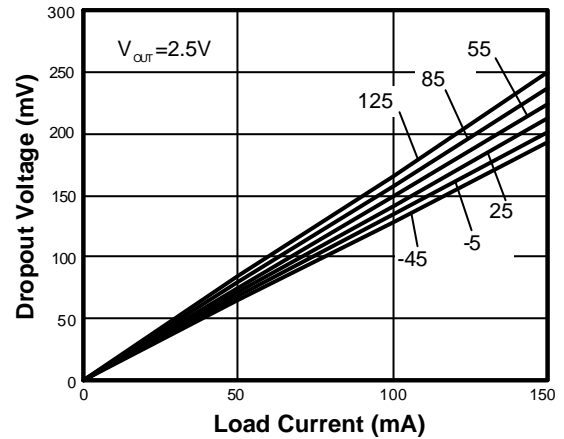
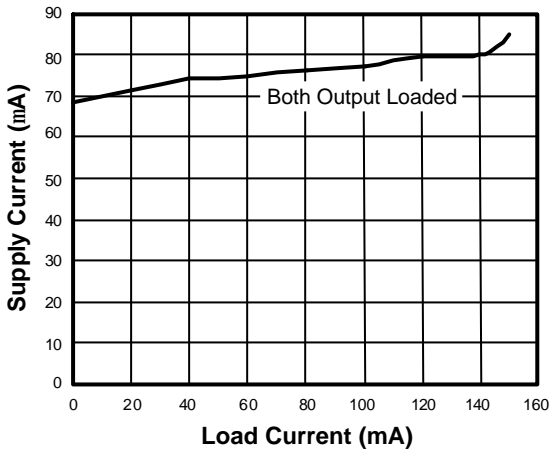
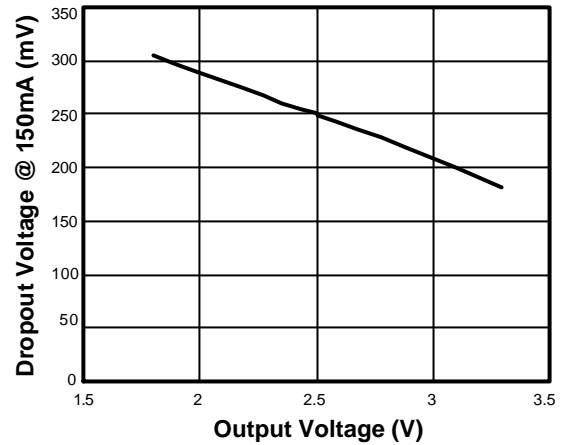
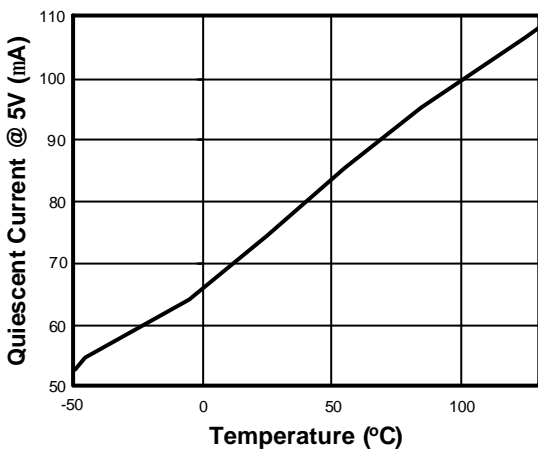
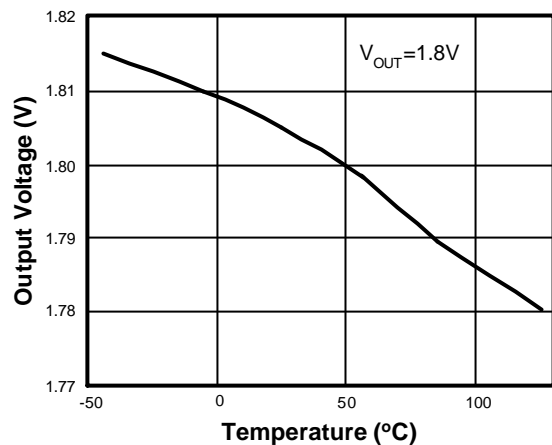
Quiescent Current vs Input Voltage

Dropout Voltage vs Load Current

Supply Current vs. Load current

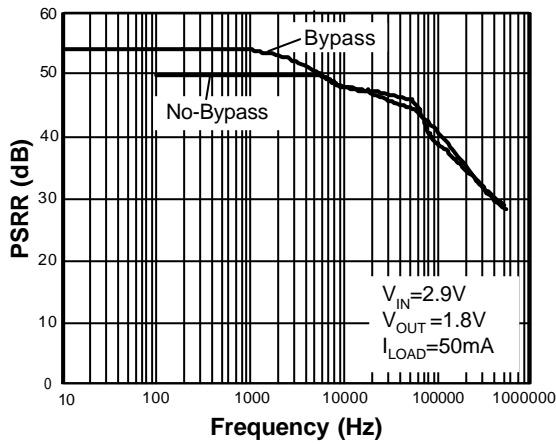
Dropout Voltage vs Output Voltage

Quiescent Current vs Temperature

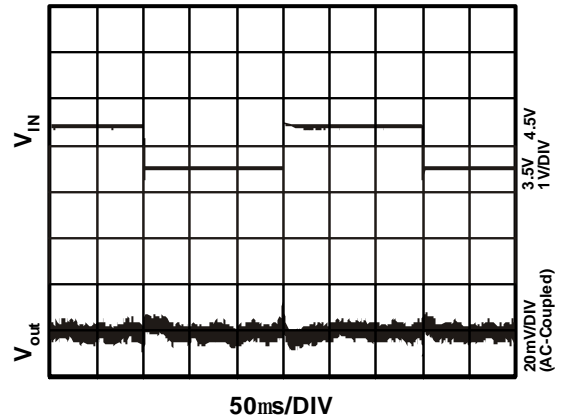
Output Voltage vs Temperature



PSRR vs. Frequency



Line Transient



Channel-to-Channel Isolation vs Frequency

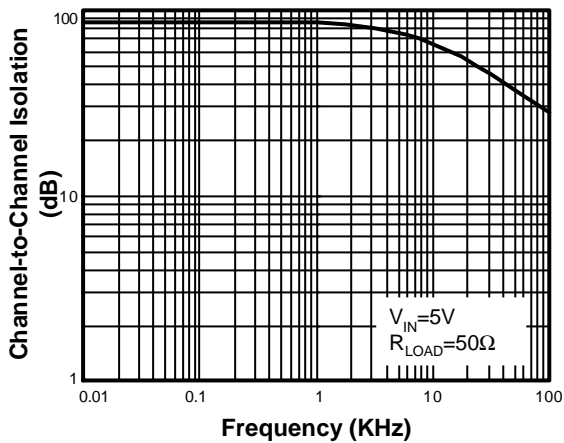

Load Transient

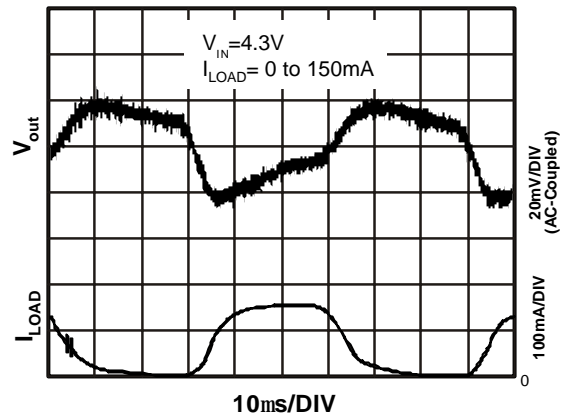

Output Noise Spectral Density

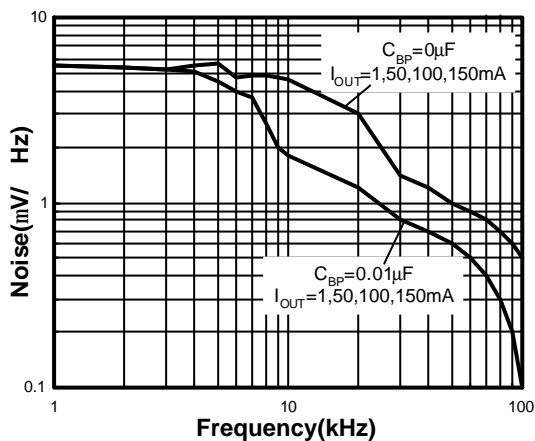

Load Transient Near Dropout

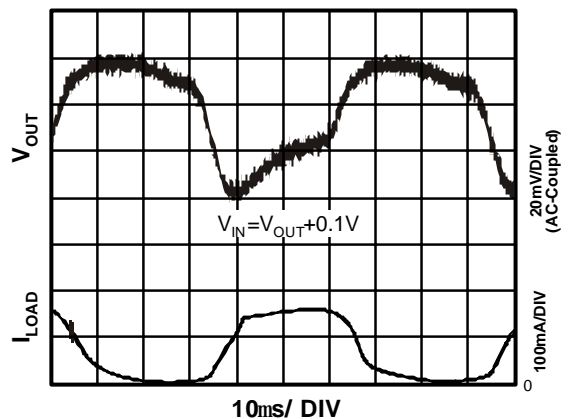



AME, Inc.

AME8750

Low-Dropout
150mA / 150mA Dual CMOS Regulator

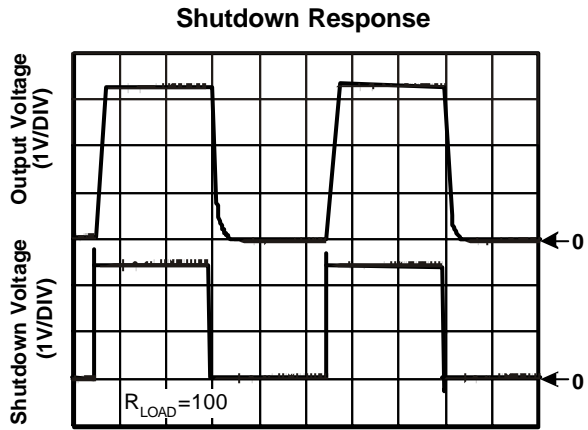



■ Date Code Rule

Marking			Date Code		Year
A	A	A	W	W	xxx0
A	A	A	W	<u>W</u>	xxx1
A	A	A	<u>W</u>	W	xxx2
A	A	A	<u>W</u>	<u>W</u>	xxx3
A	A	<u>A</u>	W	W	xxx4
A	A	<u>A</u>	W	<u>W</u>	xxx5
A	A	<u>A</u>	<u>W</u>	W	xxx6
A	A	<u>A</u>	<u>W</u>	<u>W</u>	xxx7
A	<u>A</u>	A	W	W	xxx8
A	<u>A</u>	A	W	<u>W</u>	xxx9

■ Tape & Reel Dimension

SOT-26

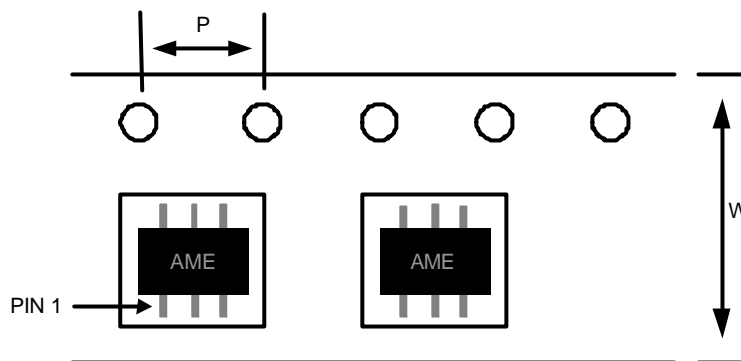

Carrier Tape, Number of Components Per Reel and Reel Size

Package	Carrier Width (W)	Pitch (P)	Part Per Full Reel	Reel Size
SOT-26	8.0±0.1 mm	4.0±0.1 mm	3000pcs	180±1 mm

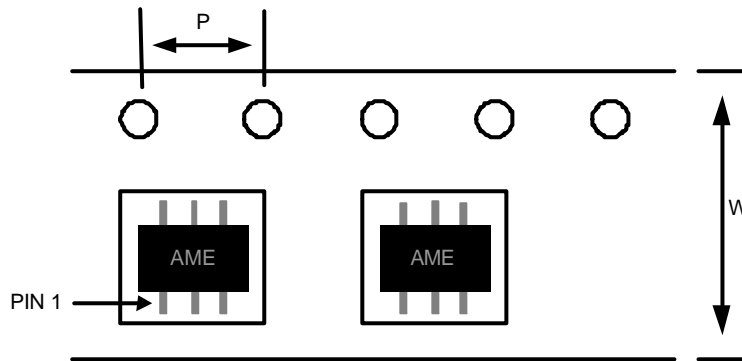
■ Tape & Reel Dimension
TSOT-26

Carrier Tape, Number of Components Per Reel and Reel Size

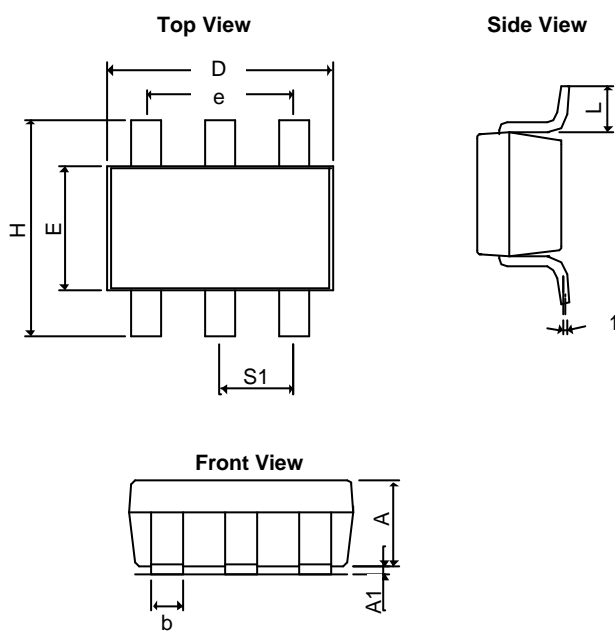
Package	Carrier Width (W)	Pitch (P)	Part Per Full Reel	Reel Size
TSOT-26	8.0±0.1 mm	4.0±0.1 mm	3000pcs	180±1 mm

■ Package Dimension
SOT-26

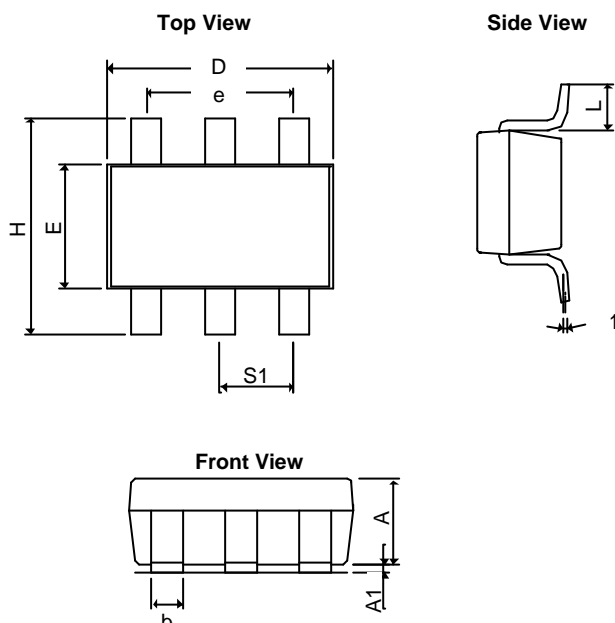
SYMBOLS	MILLIMETERS		INCHES	
	MIN	MAX	MIN	MAX
A	1.20REF		0.0472REF	
A₁	0.00	0.15	0.0000	0.0059
b	0.30	0.55	0.0118	0.0217
D	2.70	3.10	0.1063	0.1220
E	1.40	1.80	0.0551	0.0709
e	1.90 BSC		0.0748 BSC	
H	2.60	3.00	0.10236	0.11811
L	0.37REF		0.0146REF	
q1	0°	10°	0°	10°
S₁	0.95REF		0.0374REF	

TSOT-26

SYMBOLS	MILLIMETERS		INCHES	
	MIN	MAX	MIN	MAX
A+A₁	0.90	1.25	0.0354	0.0492
b	0.30	0.50	0.0118	0.0197
c	0.09	0.25	0.0035	0.0098
D	2.70	3.10	0.1063	0.1220
E	1.40	1.80	0.0551	0.0709
e	1.90 BSC		0.07480 BSC	
H	2.40	3.00	0.09449	0.11811
L	0.35BSC		0.0138BSC	
q1	0°	10°	0°	10°
S₁	0.95BSC		0.0374BSC	



www.ame.com.tw
E-Mail: sales@ame.com.tw

Life Support Policy:

These products of AME, Inc. are not authorized for use as critical components in life-support devices or systems, without the express written approval of the president of AME, Inc.

AME, Inc. reserves the right to make changes in the circuitry and specifications of its devices and advises its customers to obtain the latest version of relevant information.

© AME, Inc. , February 2006

Document: 2075-DS8750-C.01

Corporate Headquarter
AME, Inc.

2F, 302 Rui-Guang Road, Nei-Hu District

Taipei 114, Taiwan.

Tel: 886 2 2627-8687

Fax: 886 2 2659-2989

U.S.A. (Subsidiary)
Analog Microelectronics, Inc.

3100 De La Cruz Blvd., Suite 201

Santa Clara, CA. 95054-2046

Tel : (408) 988-2388

Fax: (408) 988-2489



中发网 WWW.ZFA.CN

全球最大的PDF中文下载站



中发网
www.zfa.cn

PDF 资料下载尽在中发网