

5364

Data Sheet
26110.7B

SMOKE DETECTOR WITH INTERCONNECT

The A5364CA is a low-current, CMOS circuit providing all of the required features for an ionization-type smoke detector. A networking capability allows as many as 125 units to be interconnected so that if any unit senses smoke, all units will sound an alarm. In addition, special features are incorporated to facilitate alignment and test of the finished smoke detector. This device is designed to comply with Underwriters Laboratories Specification UL217.

The internal oscillator and timing circuitry keeps standby power to a minimum by powering down the device for 1.66 seconds and sensing smoke for only 10 ms. Every 24 on/off cycles, a check is made for low battery condition. By substituting other types of sensors, or a switch for the ionization detector, this very-low power device can be used in numerous other battery-operated safety/security applications.

The A5364CA is supplied in a low-cost, 16-pin dual in-line plastic package. It is rated for continuous operation over the temperature range of 0°C to +50°C. Similar devices, with an internal timer to allow for a period of reduced sensitivity (“hush”), are available as the A5368CA. The Pb (lead) free version has 100% matte tin leadframe plating.

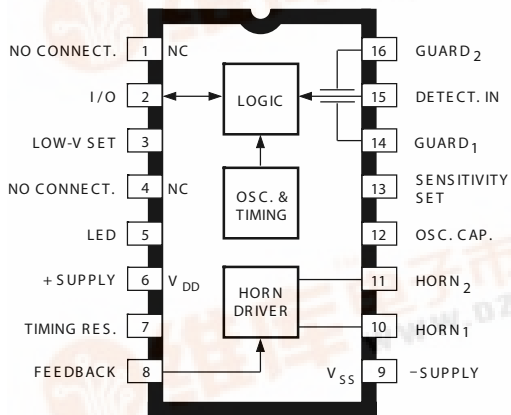

Dwg. PC-004-1

ABSOLUTE MAXIMUM RATINGS (Voltages are referenced to V_{SS})

- Supply Voltage Range,
 V_{DD} **-0.5 V to +15 V**
- Reverse Battery (10.5 V) **20 s**
- Input Voltage Range,
 V_{IN} **-0.3 V to $V_{DD} + 0.3 V$**
- Input Current, I_{IN} **10 mA**
- Operating Temperature Range,
 T_A **0°C to +50°C**
- Storage Temperature Range,
 T_S **-55°C to +125°C**

CAUTION: CMOS devices have input static protection but are susceptible to damage when exposed to extremely high static electrical charges.

FEATURES

- Interconnect Up to 125 Detectors
- Piezoelectric Horn Driver
- Guard Outputs for Detector Input
- Pulse Testing for Low Battery
- Power-ON Reset
- Internal Reverse Battery Protection
- Built-In Hysteresis Reduces False Triggering
- Temporal Horn Pattern



Use the following complete part numbers when ordering

Part Number	Pb-Free	Packing
A5364CA-T	Yes	25 pieces per tube
A5364CA	-	25 pieces per tube



5364

SMOKE DETECTOR

WITH INTERCONNECT

FUNCTIONAL BLOCK DIAGRAM AND TYPICAL APPLICATION

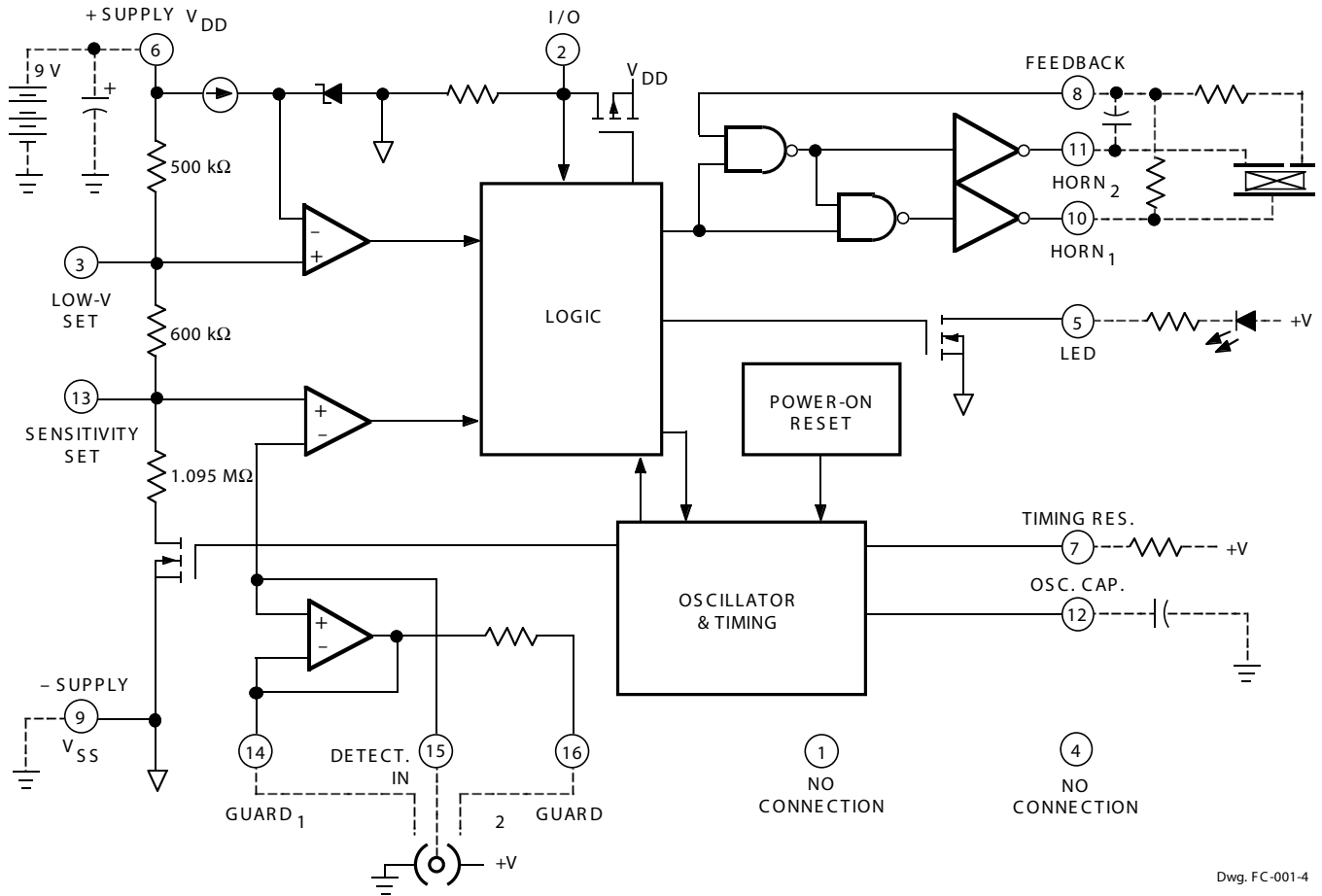

Dwg. FC-001-4

5364
SMOKE DETECTOR
WITH INTERCONNECT

ELECTRICAL CHARACTERISTICS at $T_A = +25^\circ\text{C}$, $V_{DD} = 9.0\text{ V}$, $V_{SS} = 0\text{ V}$, $C_{12} = 0.1\ \mu\text{F}$, $R_7 = 8.2\ \text{M}\Omega$ (unless otherwise noted).

Characteristic	Test Pin	Test Conditions	Limits			Units
			Min.	Typ.	Max.	
Supply Voltage Range	6	Operating	6.0	9.0	12	V
Detector Input Current	15	0 to 40% RH, $V_{IN} = 0$ to 9.0 V	—	—	± 1.0	pA
Input Offset Voltage	14-15	Active Guard	—	—	± 100	mV
	16-15	Active Guard	—	—	± 100	mV
	15-13	Detect Comparator	—	—	± 50	mV
Hysteresis	13	No Alarm to Alarm	90	130	170	mV
Common Mode Range	14-15	Guard Amplifier	2.0	—	$V_{DD} - 0.5$	V
	13-15	Smoke Comparator	0.5	—	$V_{DD} - 2.0$	V
Active Guard Impedance	14	to V_{SS}	—	10	—	k Ω
	16	to V_{SS}	—	500	—	k Ω
Oscillator Period	12	No Alarm	1.34	1.67	2.00	s
		Alarm	32	40	48	ms
Oscillator Pulse Width	4		8.0	10	12	ms
Low Voltage Threshold	6	$T_A = 0$ to 50°C	7.2	—	7.8	V
Sensitivity Adj. Voltage	13	V_{13}/V_{DD} , pin 13 open circuit	48.5	50	51.5	%
Horn Output Voltage	10-11	$I_{OUT} = 16\text{ mA}$, $V_{DD} = 9.0\text{ V}$	—	0.1	0.5	V
		$I_{OUT} = 16\text{ mA}$, $V_{DD} = 7.2\text{ V}$	—	—	0.9	V
		$I_{OUT} = -16\text{ mA}$, $V_{DD} = 9.0\text{ V}$	8.5	8.8	—	V
		$I_{OUT} = -16\text{ mA}$, $V_{DD} = 7.2\text{ V}$	6.3	—	—	V
Horn Output ON Time	10-11	Alarm (see figure, time "A")	450	500	550	ms
		Low Battery	8.0	10	12	ms
Horn Output OFF Time	10-11	Alarm (see figure, time "B")	450	500	550	ms
		Alarm (see figure, time "C")	1350	1500	1650	ms
		Low Battery	32	40	48	s
LED Output ON Current	5	$V_{DD} = 7.2\text{ V}$, $V_{OUT} = 1.0\text{ V}$	10	—	—	mA
LED Output ON Time	5	No Local Alarm; Not Latched	8.0	10	12	ms
LED Output OFF Time	5	No Alarm, In Standby	32	40	48	s

NOTE 1: Negative current is defined as coming out of (sourcing) the specified device pin.

Continued next page . . .

NOTE 2: Alarm (Smoke) Condition is defined as $V_{15} < V_{13}$; No Alarm (No Smoke) Condition as $V_{15} > V_{13}$.

5364

SMOKE DETECTOR

WITH INTERCONNECT

ELECTRICAL CHARACTERISTICS (continued)

Characteristic	Test Pin	Test Conditions	Limits			
			Min.	Typ.	Max.	Units
I/O Current	2	No Alarm, $V_{I/O} = V_{DD} - 2.0 \text{ V}$	25	—	60	μA
		Alarm, $V_{I/O} = V_{DD} - 2.0 \text{ V}$	-7.5	—	—	mA
I/O Alarm Voltage	2	External "Alarm" In	3.0	—	—	V
I/O Delay	2	"Alarm" Out	—	3.0	—	s
Supply Current	6	$V_{DD} = 9.0 \text{ V}$, No Alarm, No Loads	—	5.0	9.0	μA
		$V_{DD} = 12 \text{ V}$, No Alarm, No Loads	—	—	12	μA

NOTE 1: Negative current is defined as coming out of (sourcing) the specified device pin.

NOTE 2: Alarm (Smoke) Condition is defined as $V_{15} < V_{13}$; No Alarm (No Smoke) Condition as $V_{15} > V_{13}$.

CIRCUIT DESCRIPTION

The A5364CA is a low-current CMOS circuit providing all of the required features for an ionization-type smoke detector.

Oscillator. An internal oscillator operates with a period of 1.67 seconds during no-smoke conditions. Every 1.67 seconds, internal power is applied to the entire circuit and a check is made for smoke. Every 24 clock cycles (40 seconds), the LED is pulsed and a check is made for low battery by comparing V_{DD} to an internal reference. Because very-low currents are used in the device, the oscillator capacitor at pin 12 should be a low-leakage type (PTFE, polystyrene, or polypropylene).

Detector Circuitry. When smoke is detected, the resistor divider network that sets the sensitivity (smoke trip point) is altered to increase the sensitivity set voltage (pin 13) by typically 130 mV with no external connections to pins 3 or 13. This provides hysteresis and reduces false triggering. An active guard is provided on both pins adjacent to the detector input (pin 15). The voltage at pins 14 and 16 will be within 100 mV of the input.

This will keep surface leakage currents to a minimum and provide a method of measuring the input voltage without loading the ionization chamber. The active guard amplifier is not power strobed and thus provides constant protection from surface leakage currents. The detector input has internal diode protection against static damage.

Alarm Circuitry. If smoke is detected, the oscillator period changes to 40 ms and the horn is enabled. The horn output is typically 0.5 s ON, 0.5 s OFF, 0.5 s ON, 0.5 s OFF, 0.5 s ON, 1.5 s OFF (temporal horn pattern). During the OFF time, smoke is checked and will inhibit further alarm output if smoke is not sensed. During smoke conditions the low battery alarm is inhibited and the LED is driven at a 1 Hz rate.

Sensitivity Adjust. The detector sensitivity to smoke is set internally by a voltage divider connected between V_{DD} and V_{SS} . The sensitivity can be externally adjusted to the individual characteristics of the ionization chamber by connecting a resistor between pin 13 and V_{DD} , or between pin 13 and V_{SS} .

Low Battery. The low battery threshold is set internally by a voltage divider connected between V_{DD} and V_{SS} . The threshold can be increased by connecting a resistor between pin 3 and V_{DD} . The threshold can be decreased by connecting a resistor between pin 3 and V_{SS} . The battery voltage level is checked every 40 seconds during the 10 mA, 10 ms LED pulse. If an LED is not used, it should be replaced with an equivalent resistor (typically 500 Ω to 1000 Ω) such that the battery loading remains at 10 mA.

5364 SMOKE DETECTOR WITH INTERCONNECT

I/O. A connection is provided at pin 2 to allow multiple smoke detectors to be commoned. If any single unit detects smoke (I/O is driven high), all connected units will sound their associated horns after a nominal 3 second delay. The LED is suppressed when an alarm is signaled from an interconnected unit.

Testing. On power up, all internal counters are reset. Internal test circuitry allows for low battery check by holding pins 8 and 12 low during power up, then reducing V_{DD} and monitoring HORN₁ (pin 10). All functional tests can be accelerated by driving pin 12 with a 2 kHz square wave. The 10 ms strobe period must be maintained for proper operation of the comparator circuitry.

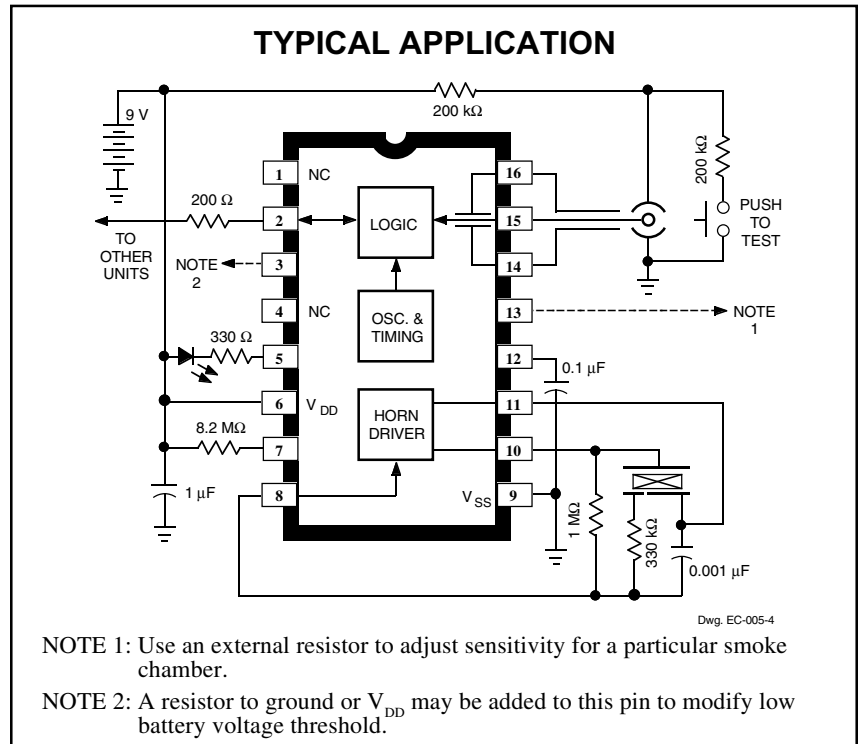

TIMING DIAGRAM IN TYPICAL APPLICATION

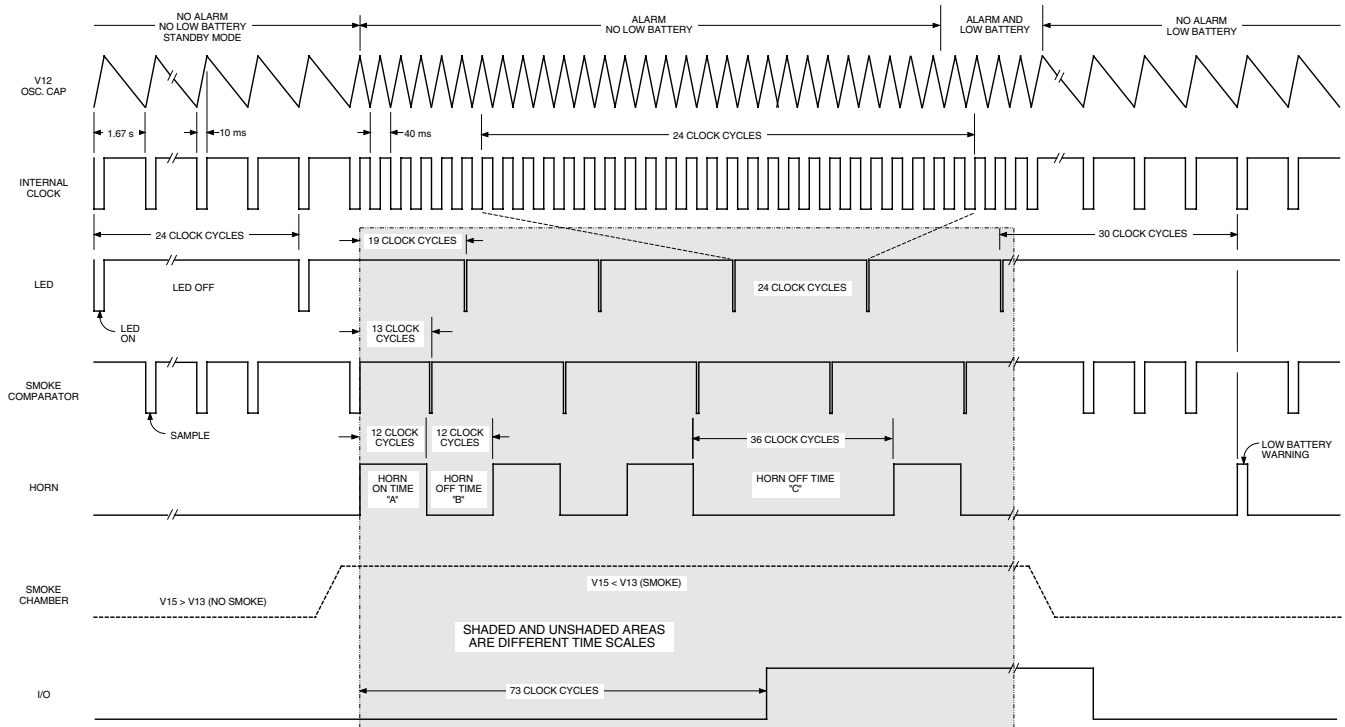

5364
SMOKE DETECTOR
WITH INTERCONNECT

I/O OPERATION

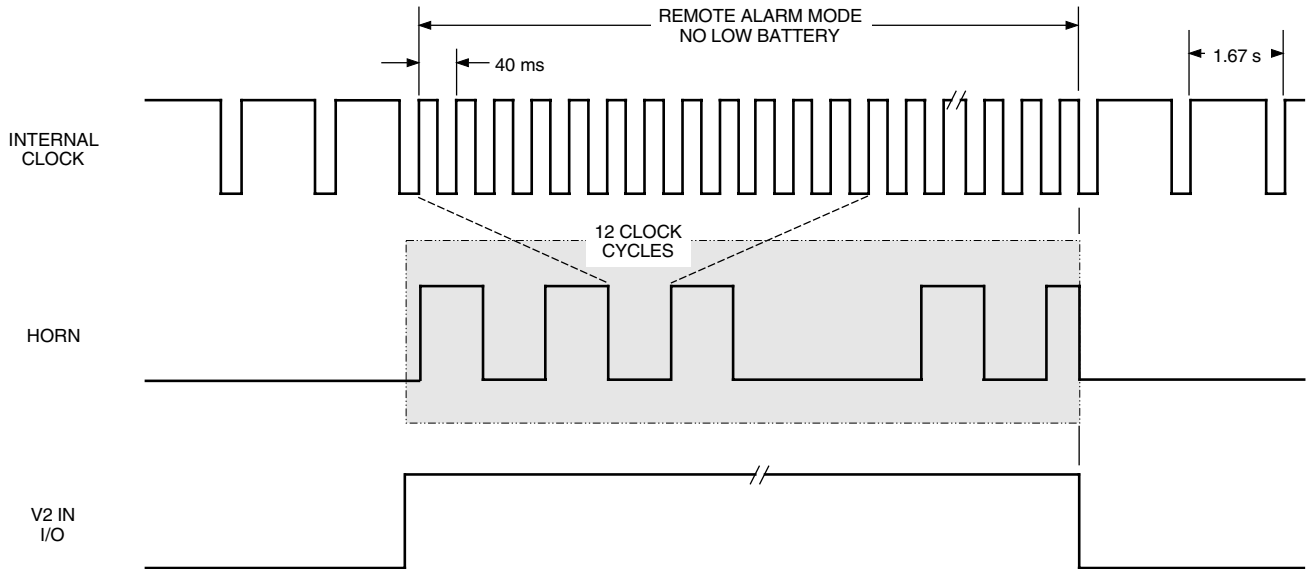

SHADED AND UNSHADED AREAS
ARE DIFFERENT TIME SCALES

HORN CYCLE NOT SELF COMPLETING
AFTER REMOTE OR LOCAL ALARM CONDITION IS REMOVED

SINGLE HORN PULSE IN PROGRESS IS SELF COMPLETING
AFTER LOCAL ALARM CONDITION IS REMOVED

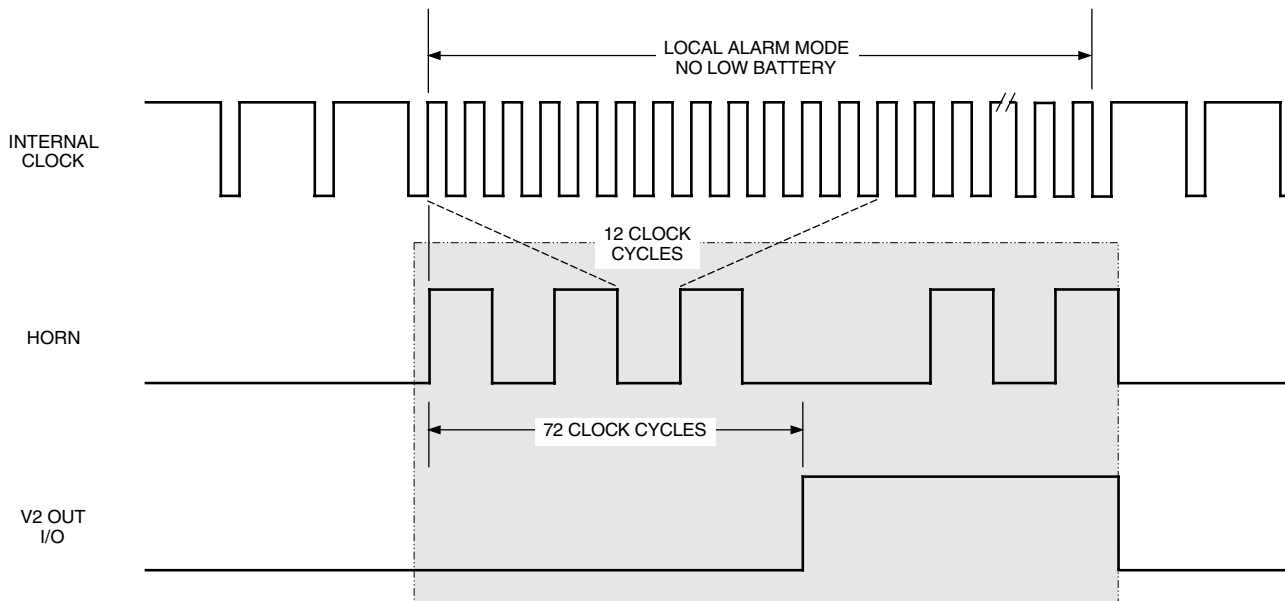

Dwg. WC-004-2

5364
SMOKE DETECTOR
WITH INTERCONNECT

Dimensions in Inches
(controlling dimensions)

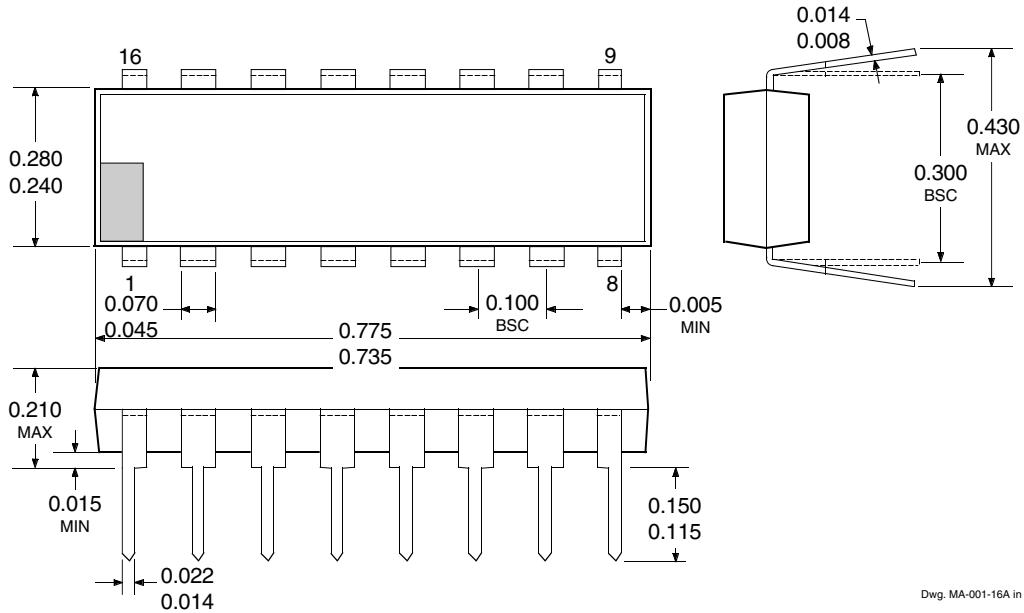

Dimensions in Millimeters
(for reference only)

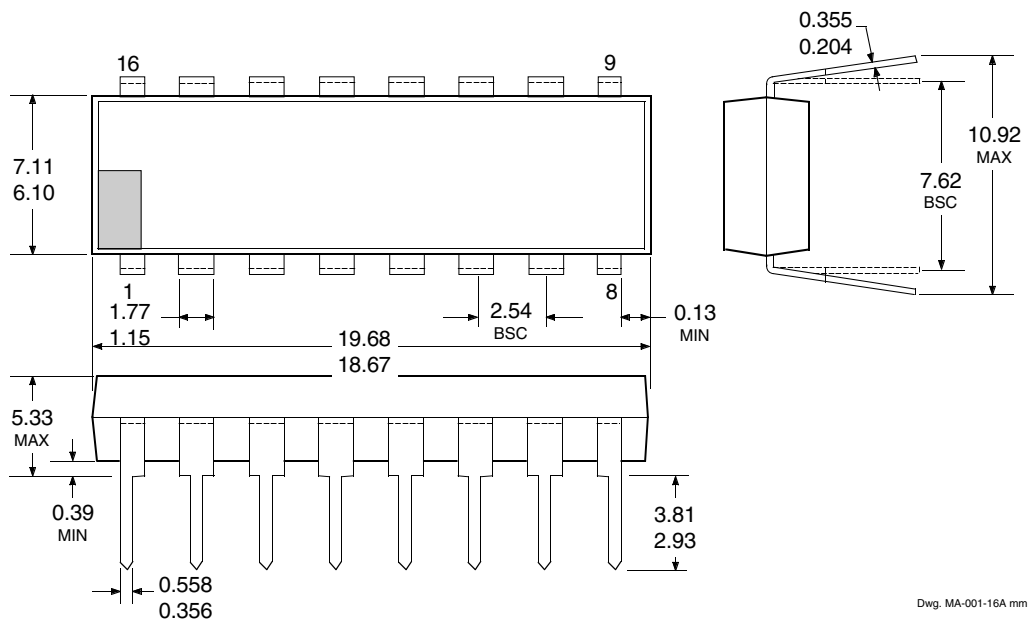

- NOTES: 1. Lead thickness is measured at seating plane or below.
 2. Lead spacing tolerance is non-cumulative.
 3. Exact body and lead configuration at vendor's option within limits shown.

5364
SMOKE DETECTOR
WITH INTERCONNECT

SAFETY & SECURITY ICs

Part Number	Function
A3054KU/SU	Multiplexed two-wire Hall-effect sensor
A5348CA	Ionization-type smoke detector with interconnect, timer, and reverse-battery protection
A5349CA	Ionization-type smoke detector with interconnect and timer for ac line operation
A5350CA	Ionization-type smoke detector with interconnect and reverse-battery protection
A5354CA	Ionization-type smoke detector with interconnect and reverse-battery protection
A5358CA	Photoelectric-type smoke detector with interconnect and timer
A5364CA	Ionization-type smoke detector with interconnect, reverse-battery protection, and temporal horn pattern
A5368CA	Ionization-type smoke detector with interconnect, timer, reverse-battery protection, and temporal horn pattern

The products described here are manufactured under one or more U.S. patents or U.S. patents pending.

Allegro MicroSystems, Inc. reserves the right to make, from time to time, such departures from the detail specifications as may be required to permit improvements in the performance, reliability, or manufacturability of its products. Before placing an order, the user is cautioned to verify that the information being relied upon is current.

Allegro products are not authorized for use as critical components in life-support devices or systems without express written approval.

The information included herein is believed to be accurate and reliable. However, Allegro MicroSystems, Inc. assumes no responsibility for its use; nor for any infringement of patents or other rights of third parties which may result from its use.



中发网 WWW.ZFA.CN

全球最大的PDF中文下载站



中发网
www.zfa.cn

PDF 资料下载尽在中发网