



10-Channel Gamma Buffer with V_{COM} Driver

ADD8710

FEATURES

- Single-supply operation: 4.5 V to 18 V
- Upper/lower buffers swing to V_S /GND
- Gamma continuous output current: >10 mA
- V_{COM} peak output current: 250 mA
- Offset voltage: 12 mV
- Slew rate: 8 V/ μ s
- Unity gain stable with large capacitive loads
- Supply current: 700 μ A per amplifier
- Compact 28-lead TSSOP
- Pb-free package
- Drop-in replacement for BUF11702

APPLICATIONS

- TFT LCD monitor panels
- TFT LCD notebook panels

GENERAL DESCRIPTION

The ADD8710 is a low cost, 10-channel gamma buffer with a V_{COM} driver that operates from a single supply. The part is designed for high resolution TFT LCD panels and is built on an advanced, high voltage CBCMOS process.

The gamma buffers have a high slew rate, minimum 10 mA output current, and a high capacitive load drive capability. The V_{COM} buffer is capable of delivering 250 mA of peak current and can also drive large capacitive loads. The ADD8710 offers wide supply range and offset voltages below 12 mV.

The ADD8710 is specified over the -40°C to $+85^{\circ}\text{C}$ temperature range and is available in a Pb-free, 28-lead TSSOP package.

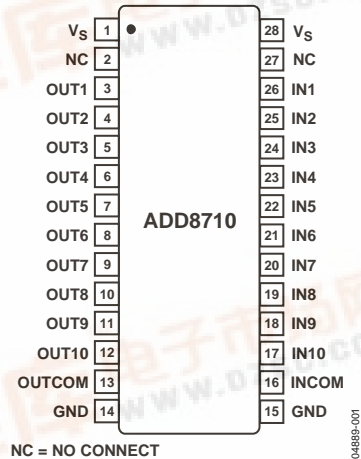

Figure 1. 28-Lead TSSOP (RU Suffix)

FUNCTIONAL BLOCK DIAGRAM

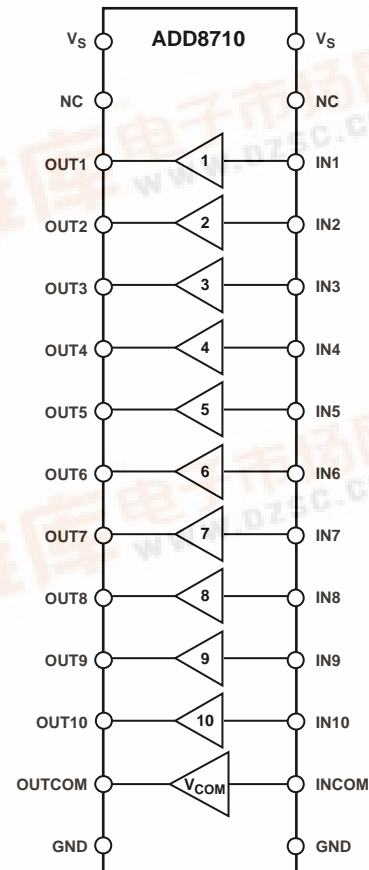

Figure 2.



ADD8710

TABLE OF CONTENTS

Electrical Characteristics	3	Typical Performance Characteristics	5
Absolute Maximum Ratings.....	4	Outline Dimensions	10
ESD Caution.....	4	Ordering Guide	10

REVISION HISTORY

13/05—Rev. 0 to Rev. A

Change to Features	1
Changes to Specifications	3
Change to Absolute Maximum Ratings.....	4

6/04—Revision 0: Initial Version

ELECTRICAL CHARACTERISTICS

$V_S = 16\text{ V}$, $V_{CM} = V_S/2$, $T_A @ 25^\circ\text{C}$, unless otherwise noted.

Table 1.

Parameter	Symbol	Condition	Min	Typ	Max	Unit
INPUT CHARACTERISTICS						
Offset Voltage	V_{OS}	Applies to all channels		4	12	mV
Offset Voltage Drift	$\Delta V_{OS}/\Delta T$	$-40^\circ\text{C} \leq T_A \leq +85^\circ\text{C}$		5		$\mu\text{V}/^\circ\text{C}$
Input Bias Current	I_B	$-40^\circ\text{C} \leq T_A \leq +85^\circ\text{C}$		0.5	1.1	μA
Input Impedance	Z_{IN}			400		k Ω
Input Capacitance	C_{IN}			1		pF
BUFFER CHARACTERISTICS						
Common-Mode Input Range	V_{CMM}		1.25		V_S	V
Buffers 1 to 5			0		$V_S - 1.25$	V
Buffers 6 to 10						
Output Voltage High (V1)	V_{OH}	$V_S = 16\text{ V}$, $V_I = 16\text{ V}$, $I_L = 10\text{ mA}$ $V_S = 10\text{ V}$, $V_I = 9.8\text{ V}$, $I_L = 10\text{ mA}$ $-40^\circ\text{C} \leq T_A \leq +85^\circ\text{C}$	15.82	15.9		V
Output Voltage High (V2 to V5)	V_{OH}	$V_S = 10\text{ V}$, $V_I = 8.5\text{ V}$, $I_L = 10\text{ mA}$ $-40^\circ\text{C} \leq T_A \leq +85^\circ\text{C}$	9.75	9.8		V
Output Voltage High (V6 to V10)	V_{OH}	$V_S = 10\text{ V}$, $V_I = 8\text{ V}$, $I_L = 10\text{ mA}$ $-40^\circ\text{C} \leq T_A \leq +85^\circ\text{C}$	9.7			V
Output Voltage Low (V1 to V5)	V_{OH}	$V_S = 10\text{ V}$, $V_I = 8.5\text{ V}$, $I_L = 10\text{ mA}$ $-40^\circ\text{C} \leq T_A \leq +85^\circ\text{C}$	8.45	8.5		V
Output Voltage Low (V6 to V9)	V_{OH}	$V_S = 10\text{ V}$, $V_I = 8\text{ V}$, $I_L = 10\text{ mA}$ $-40^\circ\text{C} \leq T_A \leq +85^\circ\text{C}$	8.4			V
Output Voltage Low (V10)	V_{OH}	$V_S = 10\text{ V}$, $V_I = 8\text{ V}$, $I_L = 10\text{ mA}$ $-40^\circ\text{C} \leq T_A \leq +85^\circ\text{C}$	7.95	8		V
Output Voltage Low (V1 to V5)	V_{OL}	$V_S = 10\text{ V}$, $V_I = 2\text{ V}$, $I_L = 10\text{ mA}$ $-40^\circ\text{C} \leq T_A \leq +85^\circ\text{C}$	7.9			V
Output Voltage Low (V6 to V9)	V_{OL}	$V_S = 10\text{ V}$, $V_I = 2\text{ V}$, $I_L = 10\text{ mA}$ $-40^\circ\text{C} \leq T_A \leq +85^\circ\text{C}$		2	2.05	V
Output Voltage Low (V10)	V_{OL}	$V_S = 10\text{ V}$, $V_I = 2\text{ V}$, $I_L = 10\text{ mA}$ $-40^\circ\text{C} \leq T_A \leq +85^\circ\text{C}$			2.10	V
Output Voltage Low (V1 to V5)	V_{OL}	$V_S = 10\text{ V}$, $V_I = 1.5\text{ V}$, $I_L = 10\text{ mA}$ $-40^\circ\text{C} \leq T_A \leq +85^\circ\text{C}$		1.5	1.55	V
Output Voltage Low (V6 to V9)	V_{OL}	$V_S = 10\text{ V}$, $V_I = 1.5\text{ V}$, $I_L = 10\text{ mA}$ $-40^\circ\text{C} \leq T_A \leq +85^\circ\text{C}$			1.60	V
Output Voltage Low (V10)	V_{OL}	$V_S = 16\text{ V}$, $V_I = 0\text{ V}$, $I_L = 10\text{ mA}$ $V_S = 10\text{ V}$, $V_I = 0.2\text{ V}$, $I_L = 10\text{ mA}$ $-40^\circ\text{C} \leq T_A \leq +85^\circ\text{C}$		0.1	0.175	V
Continuous Output Current	I_{OUT}			0.2	0.25	V
Peak Output Current	I_{PK}	$V_S = 16\text{ V}$		0.3		V
Continuous Output Current	I_{OUT}			10		mA
Peak Output Current	I_{PK}	$V_S = 16\text{ V}$		100		mA
V_{COM} CHARACTERISTICS						
Common-Mode Input Range	V_{CMM}		0		$V_S - 1.25$	V
Output Voltage High	V_{OH}	$V_S = 10\text{ V}$, $V_I = 8\text{ V}$, $I_L = 30\text{ mA}$ $-40^\circ\text{C} \leq T_A \leq +85^\circ\text{C}$	7.95	8		
Output Voltage Low	V_{OL}	$V_S = 10\text{ V}$, $V_I = 2\text{ V}$, $I_L = 30\text{ mA}$ $-40^\circ\text{C} \leq T_A \leq +85^\circ\text{C}$	7.9			
Continuous Output Current	I_{OUT}			35		mA
Peak Output Current	I_{PK}	$V_S = 16\text{ V}$		250		mA
SUPPLY CHARACTERISTICS						
Supply Voltage	V_S		4.5		18	V
Power Supply Rejection Ratio	PSRR	$V_S = 4.5\text{ V to }16.5\text{ V}$, $-40^\circ\text{C} \leq T_A \leq +85^\circ\text{C}$	70	90		dB
Total Supply Current	I_{SY}	$V_O = V_S/2$, no load $-40^\circ\text{C} \leq T_A \leq +85^\circ\text{C}$		7.7	10	mA
					11.5	mA
DYNAMIC PERFORMANCE						
Slew Rate	SR	$R_L = 2\text{ k}\Omega$, $C_L = 200\text{ pF}$	4	8		V/ μs
Bandwidth	BW	-3 dB , $R_L = 10\text{ k}\Omega$, $C_L = 200\text{ pF}$		5		MHz
Settling Time to 0.1% (Buffers)	t_s	1 V step, $R_L = 10\text{ k}\Omega$, $C_L = 200\text{ pF}$		1.1		μs
Settling Time to 0.1% (V_{COM})	t_s	1 V step, $R_L = 10\text{ k}\Omega$, $C_L = 200\text{ pF}$		0.7		μs
Phase Margin	ϕ_o	$R_L = 10\text{ k}\Omega$, $C_L = 200\text{ pF}$		45		Degree
Channel Separation				75		dB

ADD8710

ABSOLUTE MAXIMUM RATINGS

Table 2.

Parameter	Rating
Supply Voltage (V_S)	18.5 V
Input Voltage	-0.5 V to $V_S + 0.5$ V
Storage Temperature Range	-65°C to +150°C
Operating Temperature Range	-40°C to +85°C
Junction Temperature Range	-65°C to +150°C
Lead Temperature Range	300°C
ESD Tolerance (HBM)	±2500 V
ESD Tolerance (MM)	±200 V

Stresses above those listed under Absolute Maximum Ratings may cause permanent damage to the device. This is a stress rating only; functional operation of the device at these or any other conditions above those indicated in the operational sections of this specification is not implied. Exposure to absolute maximum rating conditions for extended periods may affect device reliability.

Table 3. Package Characteristics

Package Type	θ_{JA} ¹	Unit
28-Lead TSSOP (RU)	67.7	°C/W

¹ θ_{JA} is specified for worst-case conditions, i.e., θ_{JA} is specified for devices soldered onto a circuit board for surface-mount packages.

ESD CAUTION

ESD (electrostatic discharge) sensitive device. Electrostatic charges as high as 4000 V readily accumulate on the human body and test equipment and can discharge without detection. Although this product features proprietary ESD protection circuitry, permanent damage may occur on devices subjected to high energy electrostatic discharges. Therefore, proper ESD precautions are recommended to avoid performance degradation or loss of functionality.



TYPICAL PERFORMANCE CHARACTERISTICS

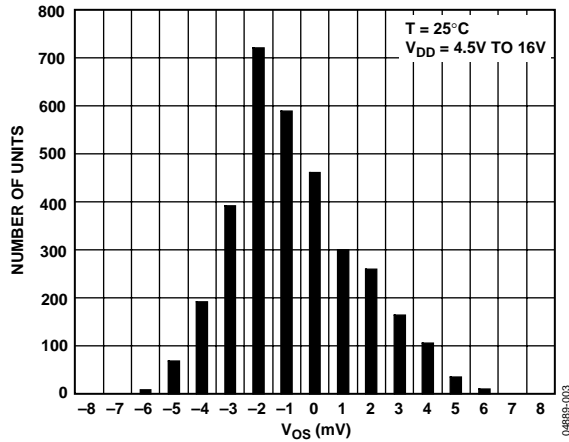

Figure 3. Input Offset Voltage

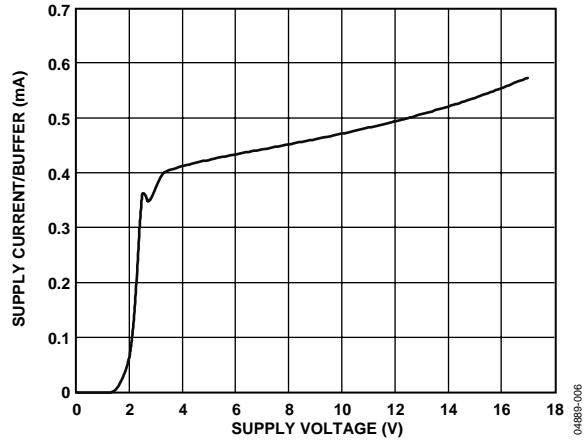

Figure 6. Supply Current/Buffer vs. Supply Voltage

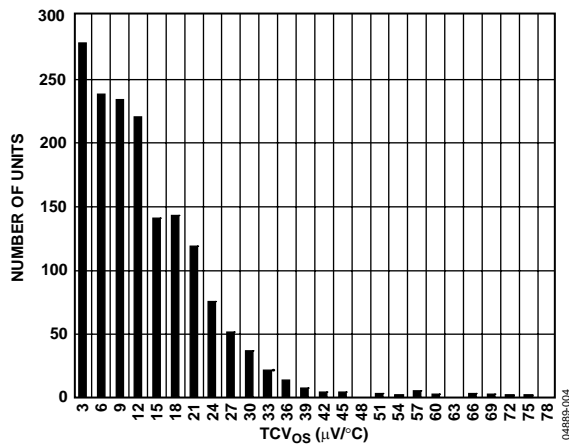

Figure 4. Input Offset Voltage Drift Distribution

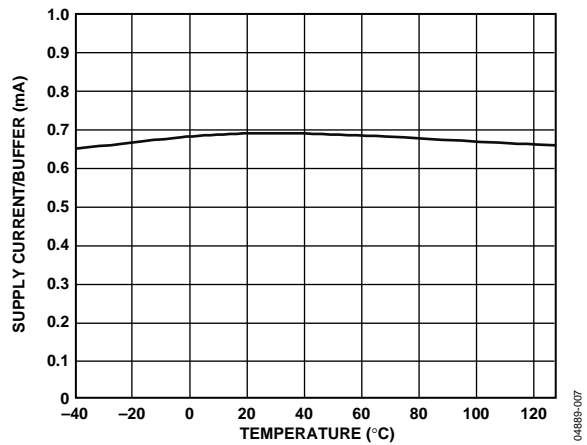

Figure 7. Supply Current/Buffer vs. Temperature

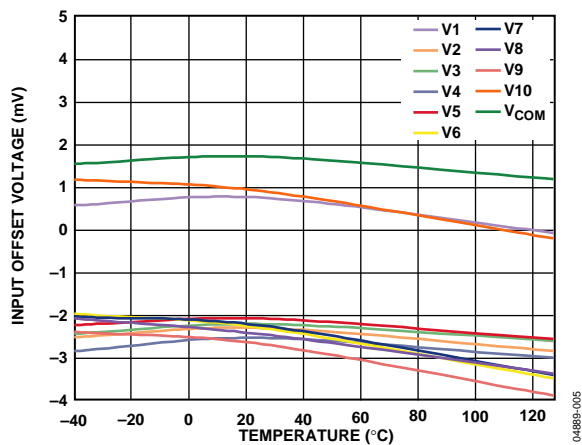

Figure 5. Input Offset Voltage vs. Temperature

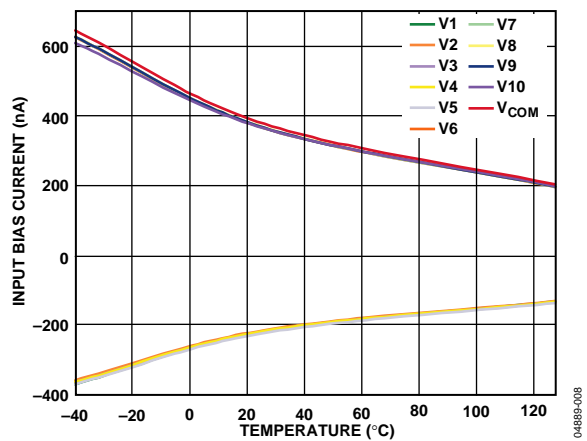

Figure 8. Input Bias Current vs. Temperature

ADD8710

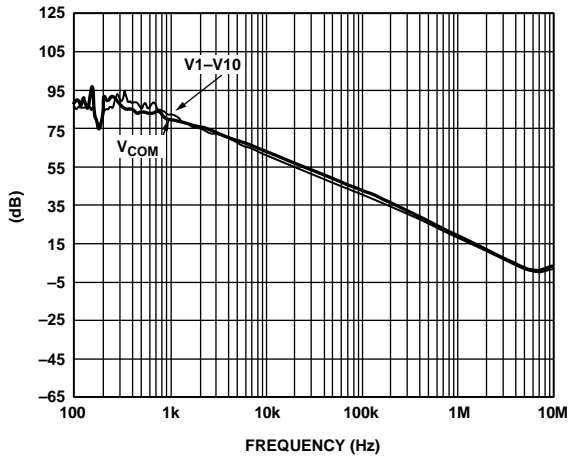

Figure 9. Power Supply Rejection Ratio vs. Frequency

04889-009

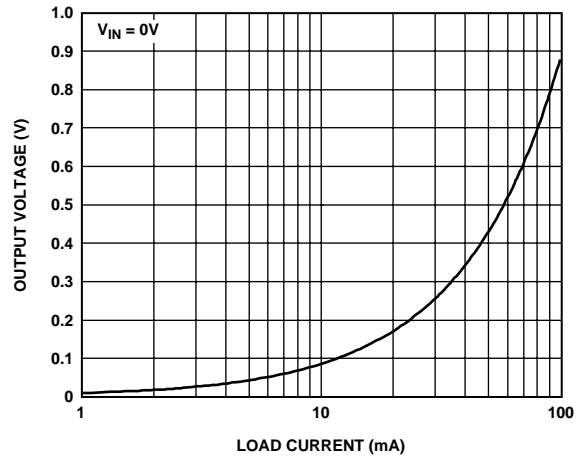

Figure 12. Channel V_{COM} Output Voltage Low vs. I Load

04889-012

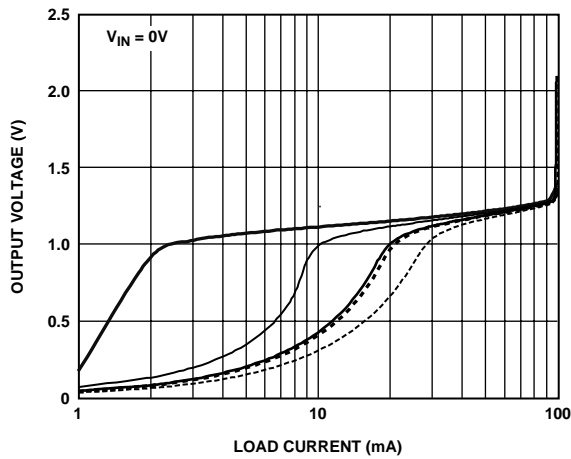

Figure 10. Channels 1 to 5 Output Voltage Low vs. I Load

04889-010

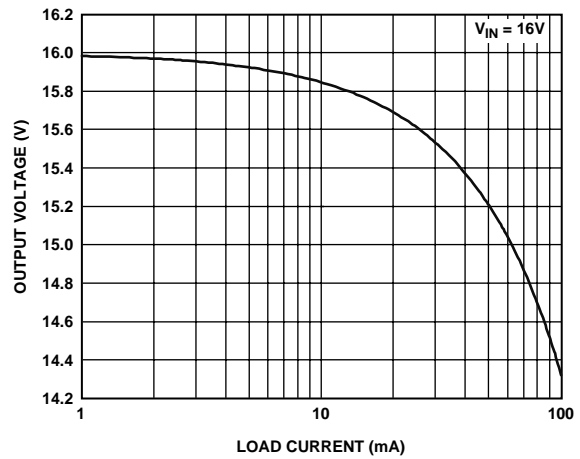

Figure 13. Channel 1 Output Voltage High vs. I Load

04889-013

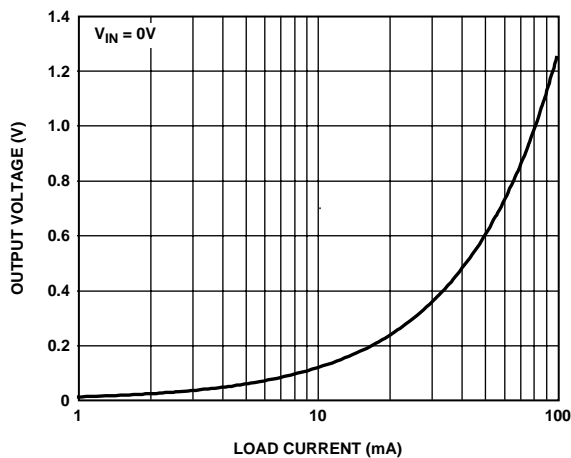

Figure 11. Channels 6 to 10 Output Voltage Low vs. I Load

04889-011

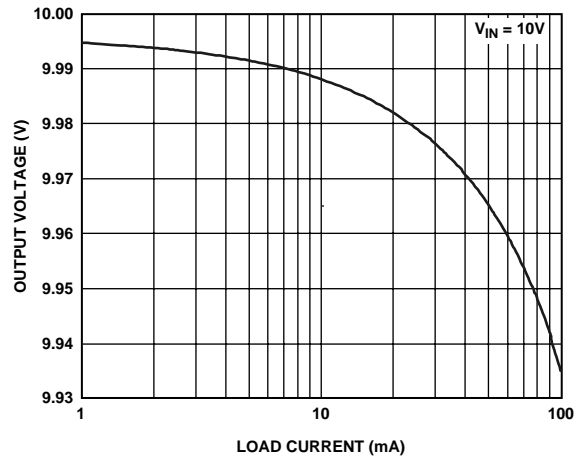

Figure 14. Channels 2 to 5 Output Voltage High vs. I Load

04889-014

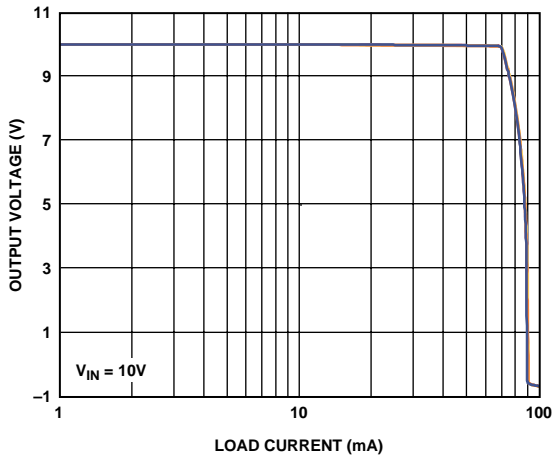

Figure 15. Channels 6 to 10 Output Voltage High vs. I Load

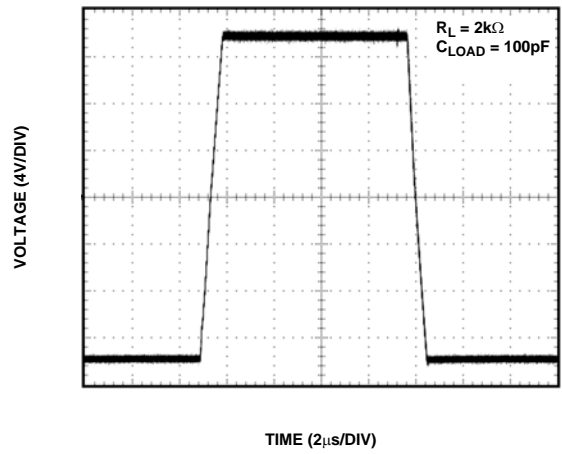

Figure 18. Large-Signal Transient Response

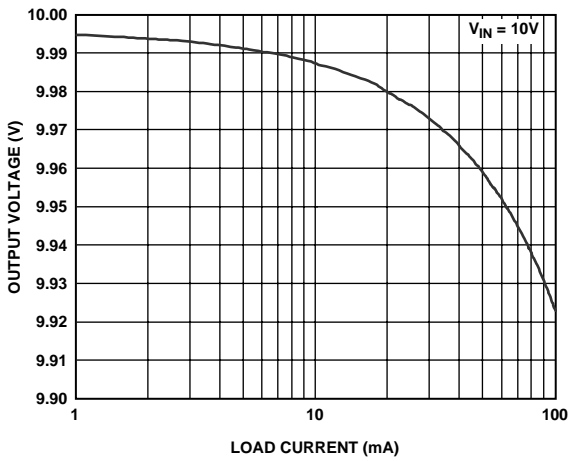

Figure 16. Channel V_{COM} Output Voltage High vs. I Load

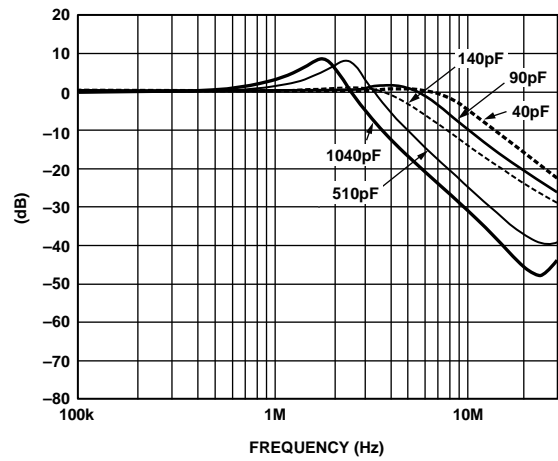

Figure 19. Channels 1 to 5 Frequency Response vs. Capacitive Loading

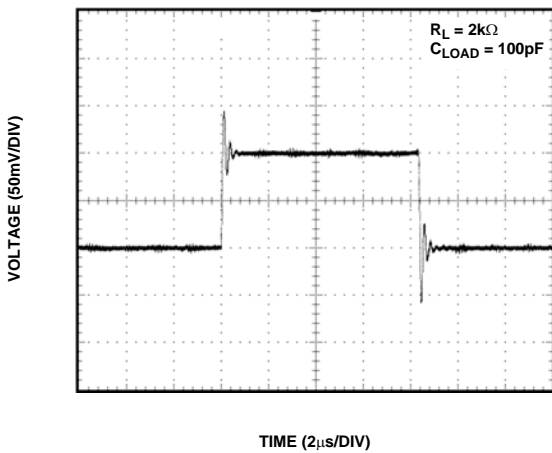

Figure 17. Small-Signal Transient Response

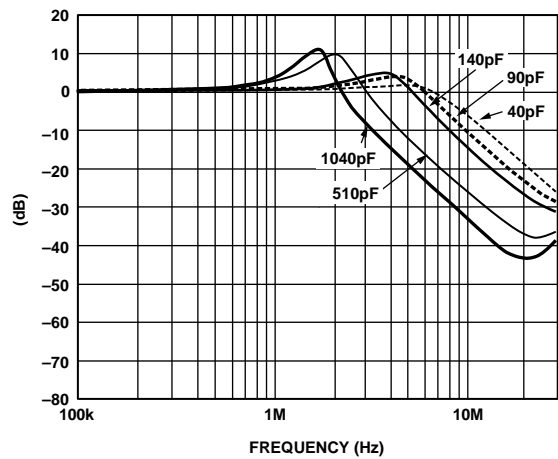

Figure 20. Channels 6 to 10 Frequency Response vs. Capacitive Loading

04889-015

04889-018

04889-016

04889-019

04889-017

04889-020

ADD8710

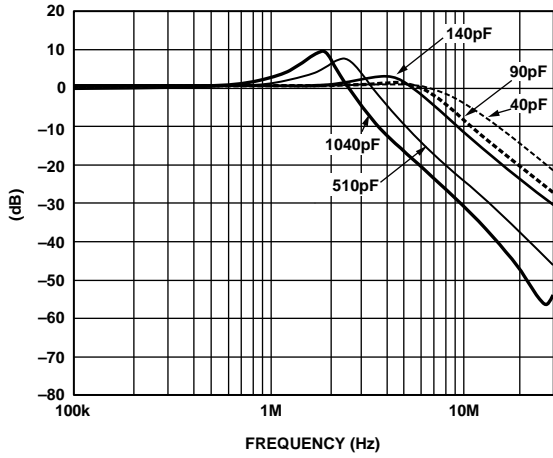

04889-021

Figure 21. Channel V_{COM} Frequency Response vs. Capacitive Loading

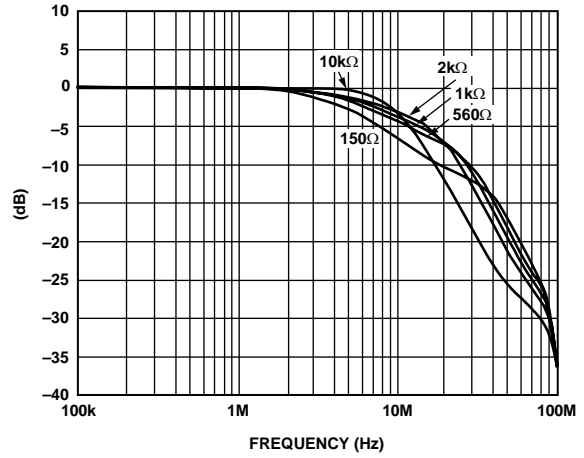

04889-024

Figure 24. Channel V_{COM} Frequency Response vs. Resistive Loading

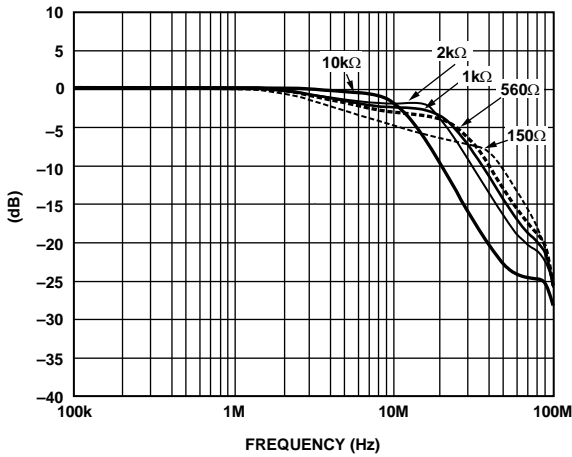

04889-022

Figure 22. Channels 1 to 5 Frequency Response vs. Resistive Loading

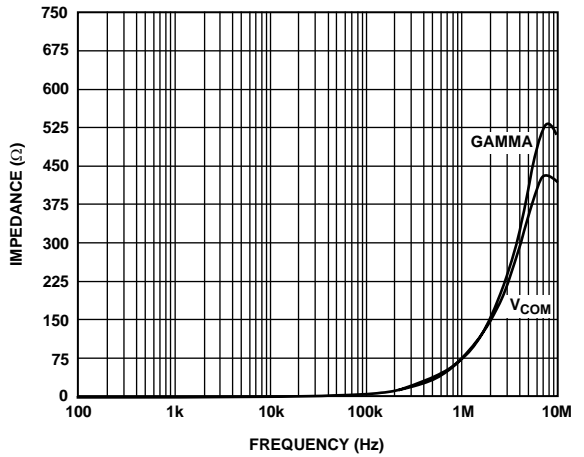

04889-025

Figure 25. Closed-Loop Output Impedance vs. Frequency

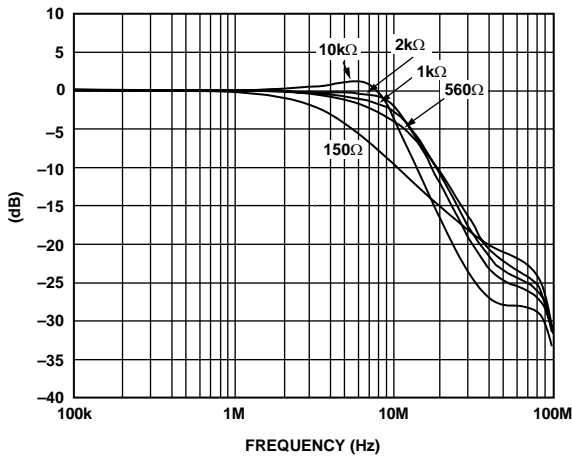

04889-023

Figure 23. Channels 6 to 10 Frequency Response vs. Resistive Loading

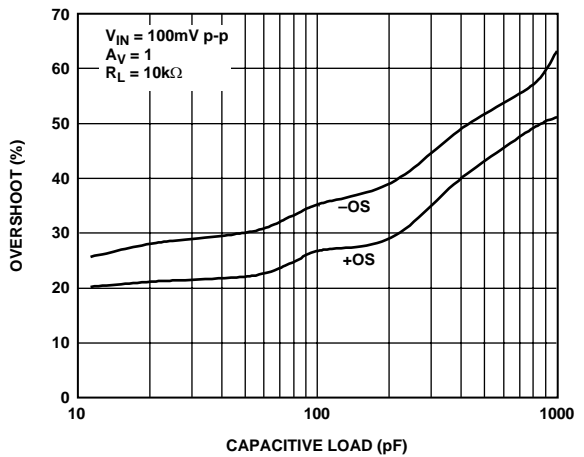

04889-026

Figure 26. Channels 1 to 5 Small-Signal Overshoot vs. Load Capacitance

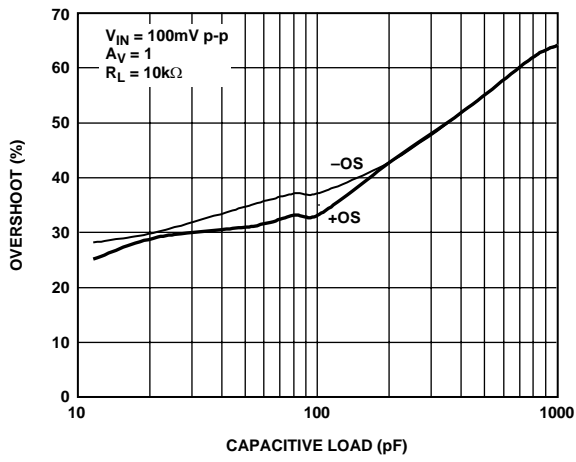

04889-027

Figure 27. Channels 6 to 10 Small-Signal Overshoot vs. Load Capacitance

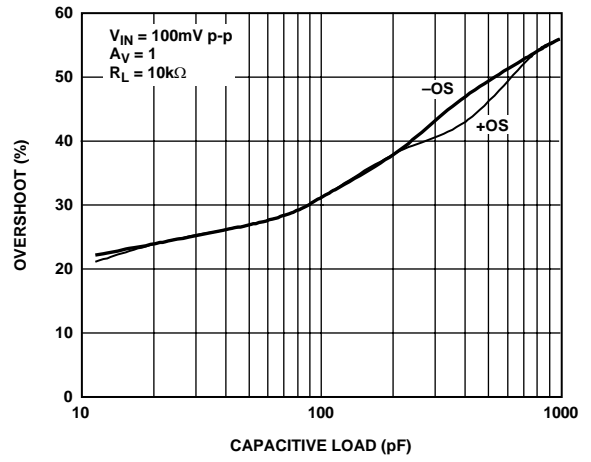

04889-028

Figure 28. Channel V_{COM} Small-Signal Overshoot vs. Load Capacitance

ADD8710

OUTLINE DIMENSIONS

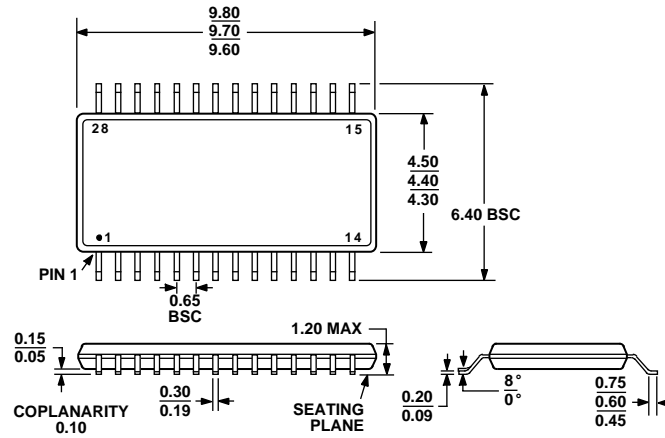

COMPLIANT TO JEDEC STANDARDS MO-153AE

Figure 29. 28-Lead Thin Shrink Small Outline Package [TSSOP]
(RU-28)

Dimensions shown in millimeters

ORDERING GUIDE

Model	Temperature Range	Package Description	Package Option
ADD8710ARUZ ¹	-40°C to +85°C	28-Lead TSSOP	RU-28
ADD8710ARUZ-REEL ¹	-40°C to +85°C	28-Lead TSSOP	RU-28

¹ Z = Pb-free part.

NOTES

ADD8710

NOTES



中发网 WWW.ZFA.CN

全球最大的PDF中文下载站



中发网
www.zfa.cn

PDF 资料下载尽在中发网