



Isolated Linearized RTD Input

5B34

FEATURES

- Amplifies, Protects, Filters, and Isolates Analog Input.**
- Linearize a wide variety of 2 & 3 wire RTDs. (True 4-wire RTD measurements are provided by the 5B35).**
- Generates an output of 0 to +5V.**
- Module circuitry can withstand 240v rms at the input screw-terminals.**
- All 5B34 series modules are mix-and-match and Hot Swappable.**

APPLICATIONS

- Industrial signal conditioning**
- Industrial signal isolation**
- Industrial signal filtering**
- Signal Linearization**

PRODUCT OVERVIEW

The 5B Series represents an innovative generation of low cost, high performance plug-in signal conditioners. Designed for industrial applications, these modules incorporate highly reliable transformer-based isolation and automated surface-mount manufacturing technology. They are compact, economical components whose performance exceeds that available from more expensive devices. Combining 1500 V rms continuous isolation, +0.05% calibrated accuracy, small size and low cost, the 5B Series is an attractive alternative to expensive signal conditioners and in-house designs

All modules are potted and identical in pin-out and size (2.27" x 2.32" x 0.595"). They can be mixed and matched, permitting users to address their exact needs, and may be "hot swapped" without disturbing field wiring or power. The isolated input modules provide 0 to +5V or +5V outputs and accept J, K, T, E, R, S, N, or B type thermocouples.

These modules feature complete signal conditioning functions including 240 V rms input protection, filtering, chopper stabilized low drift +1 uV/oC amplification, 1500 V rms isolation, and sensor excitation when required.

All modules feature excellent common mode rejection and meet industrial transient surge withstand specifications.

FUNCTIONAL BLOCK DIAGRAM

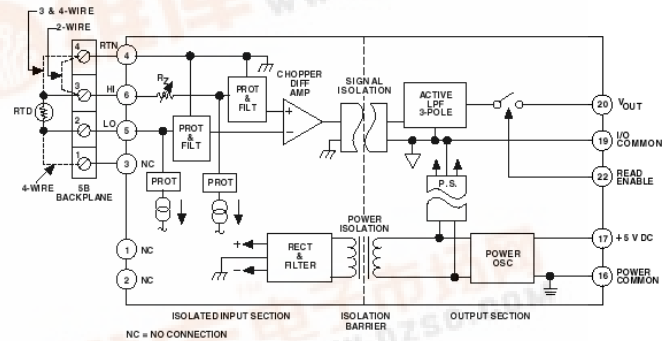

Figure 1. 5B34 Functional Block Diagram

There are also a number of backplanes and mounting sockets which provide a complete signal conditioning solution for end users. Each backplane incorporates screw terminals for field wiring inputs and outputs and cold junction sensors for thermocouple applications.

These signal conditioners are designed to provide an easy and convenient solution to signal conditioning problems of both designers and end users in measurement and control applications. Typical uses include microcomputer-based measurement systems, standard data acquisition systems, programmable controllers, analog recorders and dedicated control systems. The 5 B series modules are ideally suited to applications where monitoring and control of temperature, pressure, flow, rotation and other analog signals are required.

The 5B Series modules and backplanes are approved by Factory Mutual (FM) and the 5B Series modules are approved by the Canadian Standards Association (CSA) for use in Class 1, Division 2, Groups A, B, C, and D locations. These approvals certify that the 5B Series is suitable for use in locations where a hazardous concentration of flammable gas may exist only under fault conditions of operation. Equipment of this category is called "non-incendive" and they need no special enclosures or other physical safeguards. The 5B series modules and backplanes have been tested and passed the stringent heavy industrial requirements of the EU's electromagnetic compatibility (EMC) directive – EN50082-1 and EN50081-2. When used according to installation directions (refer to 5B series User Manual), any errors caused by EMI/RFI interference will be less than 0.1% of the full scale 5B measurement range for field strengths up to 10 V/M and frequencies up to 1 GHz.



Information furnished by Analog Devices is believed to be accurate and reliable. However, no responsibility is assumed by Analog Devices for its use, nor for any infringements of patents or other rights of third parties that may result from its use. Specifications subject to change without notice. No license is granted by implication or otherwise under any patent or patent rights of Analog Devices. Trademarks and registered trademarks are the property of their respective companies.

GENERAL DESCRIPTION

The 5B34 is a single-channel signal conditioning module that amplifies, protects, filters, linearizes, and isolates a wide variety of two and three-wire RTDs. For true four-wire RTD measurements please refer to the 5B35 model.

The 5B34 protects the computer side from damage due to field-side over-voltage faults. The module withstands 240 V rms at the input terminals without damage thereby shielding the internal computer-side circuitry from field-side over-voltage conditions. In addition, the 5B34 is mix-and-match and hot swappable with all other 5B Series input modules, so can be inserted or removed from any socket in the same backplane without disrupting system power.

Two identical sources provide excitation current for the RTD. For three-wire RTDs, the second current flows through the third RDT lead so as to cancel the effects of (equal) lead resistance; this current also flows through a stable resistor laser-trimmed to the RTD value that sets the differential amplifier input and (module) output to zero volts at that scale point. The current sources and the amplifier input are protected to withstand input over-voltage up to 240 V rms.

A differential chopper-stabilized input amplifier provides stable gain and exceptionally low drift. This allows the use of very low RTD excitation current to minimize self-heating and preserve

measurement accuracy. Along with module gain and zero settings, a feedback linearizer is laser-trimmed. Custom versions of 5N34 can be laser-trimmed to meet special requirements.

Internal multi-pole low-pass filtering with a four-Hz cutoff (-3dB) enhances normal-mode (noise on signal) and common-mode (noise on signal return) rejection at 50/60 Hz, enabling accurate measurement of small signals in high electrical noise.

Signal isolation by transformer coupling uses a proprietary modulation technique for linear, stable and reliable performance. The differential input circuit on the field side is fully floating, eliminating the need for any input grounding. A demodulator on the computer side of the signal transformer recovers the original signal, which is then filtered and buffered to provide a low-noise, low-impedance output signal. The output common must be kept within $\pm 3V$ of power common.

A series output switch eliminates the need for external multiplexing in many applications. The switch is turned on by an active-low enable input. If the switch is to be on at all times, the enable-input should be grounded to power common as it is on the 5B01 and 5B08 backplanes.



Figure 2

5B34—SPECIFICATIONS

5B34 Models Available

Model	Range	Output Range	Accuracy
5B34-01	100 Ω Platinum, $\alpha = 0.00385^*$ -100°C to +100°C (-148°F to +212°F)	0 V to +5 V	$\pm 0.32^\circ\text{C}$
5B34-02	0°C to +100°C (+32°F to 212°F)	0 V to +5 V	$\pm 0.13^\circ\text{C}$
5B34-03	0°C to +200°C (+32°F to 392°F)	0 V to +5 V	$\pm 0.26^\circ\text{C}$
5B34-04	0°C to +600°C (+32°F to 1112°F)	0 V to +5 V	$\pm 0.78^\circ\text{C}$
5B34-C-01	10 Ω Copper, $\alpha = 0.004274$ 0°C to +120°C (10 Ω @ 0°C) (+32°F to +248°F)	0 V to +5 V	$\pm 0.23^\circ\text{C}$
5B34-C-02	0°C to +120°C (10 Ω @ 25°C) (+32°F to +248°F)	0 V to +5 V	$\pm 0.23^\circ\text{C}$
5B34-N-01	120 Ω Nickel, $\alpha = 0.00672$ 0°C to +300°C (+32°F to +572°F)	0 V to +5 V	$\pm 0.40^\circ\text{C}$
5B34-Custom	*	*	

* Custom Input/Output ranges are available including versions for the 100 Ω Platinum RTD with $\alpha = 0.003916$. Refer to configuration guide.

5B34 Specifications

(typical @ +25°C and $V_s = +5$ V dc)

Description	Model 5B34
Input Ranges	
Standard Ranges	Refer to Model Table
Custom Ranges	-200°C to +850°C (100 Ω Platinum) -80°C to +320°C (120 Ω Nickel) -100°C to +260°C (10 Ω Copper)
Output Range ($R_L > 50$ k Ω)	0 V to +5 V
Accuracy²	
Initial @ +25°C	$\pm 0.05\%$ Span $\pm 0.04\Omega$ * ± 0.05 (R_z^1)
Conformity Error ³	$\pm 0.05\%$ Span
Input Offset vs. Temperature	$\pm 0.02^\circ\text{C}/^\circ\text{C}$
Output Offset vs. Temperature	± 20 $\mu\text{V}/^\circ\text{C}$
Gain vs. Temperature	$\pm 0.005\%$ of Reading/ $^\circ\text{C}$
Input Bias Current	± 3 nA
Input Resistance	
Power On	5 M Ω
Power Off	40 k Ω
Overload	40 k Ω
Noise	
Input, 0.1 Hz to 10 Hz Bandwidth	0.2 μV rms
Output, 100 kHz Bandwidth	200 μV rms
Bandwidth, -3 dB	4 Hz

Output Rise Time, 10% to 90% Span	200 ms
Common-Mode Voltage (CMV)	
Input-to-Output, Continuous	1500 V rms, maximum
Output-to-Power, Continuous ⁴	±3 V, maximum
Transient	ANSI/IEEE C37.90.1-1989
Common Mode Rejection (CMR)	
1 k Ω Source Imbalance, 50/60 Hz	160 dB
Normal Mode Rejection 50/60 Hz	60 dB
Sensor Excitation Current	
100 Ω Pt, 120 Ω Ni	0.25 mA
10 Ω Cu	1.0 mA
Lead Resistance Effect	
100 Ω Pt, 120 Ω Ni	±0.02°C/ Ω
10 Ω Cu	±0.2°C/ Ω
Input Protection	
Continuous	240 V rms, maximum
Transient	ANSI/IEEE C37.90.1-1989
Output Resistance	50 Ω
Voltage Output Protection	Continuous Short to Ground
Output Selection Time	6 μ s @ C _{load} = 0 to 2,000 pF
Output Enable Control	
Max Logic "0"	+1 V
Min Logic "1"	+2.5 V
Max Logic "1"	+36 V
Input Current "0"	0.4 mA
Power Supply Voltage	+5 V ±5%
Power Supply Current	30 mA
Power Supply Sensitivity, RTI	
100 Ω Pt, 120 Ω Ni	±0.05°C/V
10 Ω Cu	±0.5°C/V
Mechanical Dimensions	2.275" x 2.375" x 0.595" (57.8 mm x 59.1 mm x 15.1 mm)
Environmental	
Rated Performance	-25°C to +85°C
Operating	-40°C to +85°C
Storage	-40°C to +85°C
Relative Humidity	0 to 93% @ +40°C non-condensing
RFI Susceptibility	±0.5% Span error @ 400 MHz, 5 Watt, 3 ft

* ±0.025 Ω For Cu RTD's; ±0.1 Ω For Ni RTD's.

¹ R_Z is the value of the RTD resistance at the lowest point of the measurement range.

² Includes the combined effects of repeatability, hysteresis, and conformity error. Loads heavier than 50 k Ω will degrade conformity and gain temperature coefficient.

³ For Pt RTD's only; other types may vary.

⁴ The output common must be kept within ±3 V of power common.

Specifications subject to change without notice.

PIN CONFIGURATIONS AND FUNCTIONAL DESCRIPTIONS

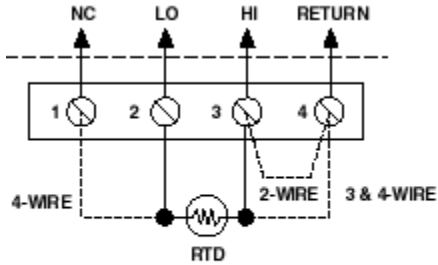

NOTE: 4-WIRE RTD SENSORS MAY BE USED WITH THE 5B34 AS SHOWN. FOR HIGHEST ACCURACY, MODEL 5B35 SHOULD BE USED WITH 4-WIRE RTD.

Figure 3 5B34 Input Field Connections

Table 1. Pin Function Descriptions—

Pin No.	Description
1	NC
2	LO
3	HI
4	RETURN

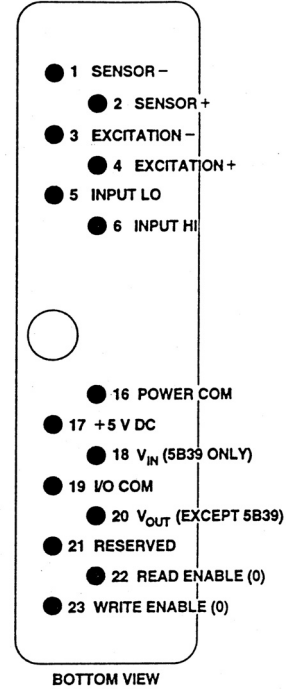
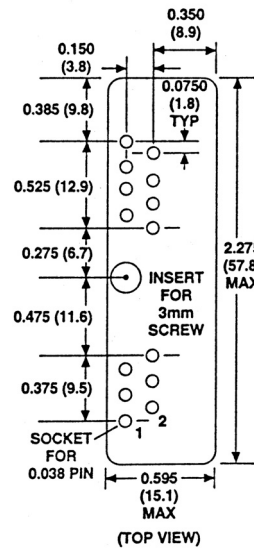

Figure 4 . Model 5B Series Module, with pin-out assignments.

ESD CAUTION

ESD (electrostatic discharge) sensitive device. Electrostatic charges as high as 4000 V readily accumulate on the human body and test equipment and can discharge without detection. Although this product features proprietary ESD protection circuitry, permanent damage may occur on devices subjected to high energy electrostatic discharges. Therefore, proper ESD precautions are recommended to avoid performance degradation or loss of functionality.



OUTLINE DIMENSIONS

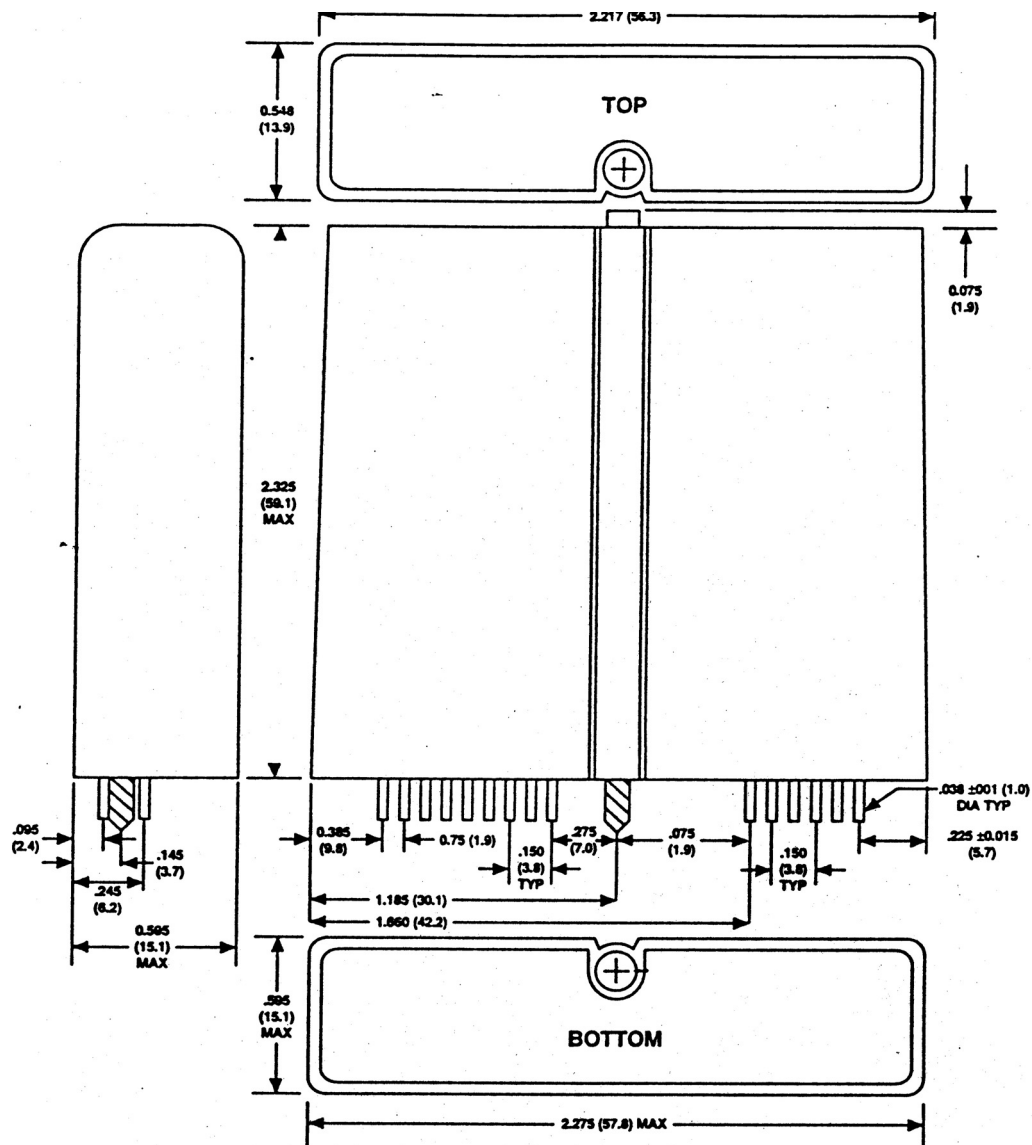

Figure 5. Outline Dimensions

NOTES

NOTES



中发网 WWW.ZFA.CN

全球最大的PDF中文下载站



中发网
www.zfa.cn

PDF 资料下载尽在中发网



中发网 WWW.ZFA.CN

全球最大的PDF中文下载站



中发网
www.zfa.cn

PDF 资料下载尽在中发网



中发网 WWW.ZFA.CN

全球最大的PDF中文下载站



中发网
www.zfa.cn

PDF 资料下载尽在中发网