



# REF-01/REF-02

## Precision Voltage References

### FEATURES

- Trimmed Output  $\pm 0.3\%$
- Low Drift— $5\text{ppm}/^\circ\text{C}$  Typ
- Low Noise— $3\text{ppm}(\text{p-p})$
- High Line Rejection
- Temperature Output—REF-02
- Low Supply Current  $1.4\text{mA}$  Max

### APPLICATIONS

- A/D and D/A Converters
- Precision Regulators
- Constant Current Sources
- V/F Converters
- Bridge Excitation

### DESCRIPTION

The REF-01/REF-02 are precision 10V and 5V bandgap references which provide stable output voltages over a wide range of operating conditions. Output voltage is accurate to  $\pm 0.3\%$  with a low  $5\text{ppm}/^\circ\text{C}$  typical temperature coefficient. The REF-01 and REF-02 are excellent choices for applications where low drift, moderate accuracy, low power consumption and low cost are considerations.

The REF-02 includes a temperature output pin which provides a linear voltage proportional to absolute temperature.

For lower drift and higher accuracy references, please see the LT1019 and LT1021 data sheets.

LT, LTC and LT are registered trademarks of Linear Technology Corporation.

### TYPICAL APPLICATION

Ultra Linear Strain Gauge Amplifier

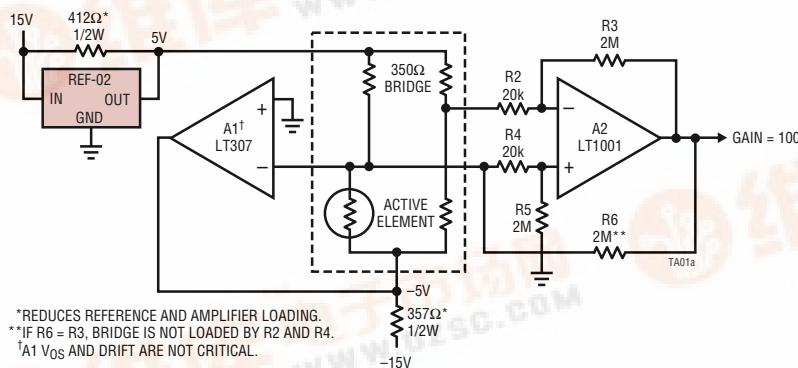

Output Voltage Temperature Drift

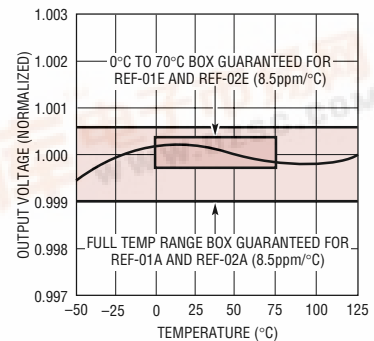

# REF-01/REF-02

## ABSOLUTE MAXIMUM RATINGS (Note 1)

REF-01/REF-02 A, E, H .....	40V	Storage Temperature Range .....	-65°C to 150°C
REF-01C/REF-02C .....	30V	Operating Temperature	
Power Dissipation .....	500mW	REF-01/REF-02, REF-01A/REF-02A ...	-55°C to 125°C
Output Short-Circuit Duration		REF-01E/REF-02E, REF-01H/REF-02H,	
To Ground .....	Indefinite	REF-01C/REF-02C, REF-01D/REF-02D ....	0°C to 70°C
To $V_{IN} \leq 16V$ .....	Indefinite	Lead Temperature (Soldering, 10 sec) .....	300°C
To $V_{IN} > 16V$ .....	Not Allowed		

## PACKAGE/ORDER INFORMATION

<p><b>OBSELETE PACKAGE</b> Consider the N Package for Alternate Source</p>	<b>ORDER PART NUMBER</b> REF01AH    REF02AH REF01H    REF02H REF01EH    REF02EH REF01HH    REF02HH REF01CH    REF02CH REF02DH		<p><b>OBSELETE PACKAGE</b> Consider the N Package for Alternate Source</p>	<b>ORDER PART NUMBER</b> REF01EN8    REF02EN8 REF01HN8    REF02HN8 REF01CN8    REF02CN8 REF02DN8 REF01EJ8    REF02EJ8 REF01HJ8    REF02HJ8 REF01CJ8    REF02CJ8 REF02DJ8	
	<p>Consult LTC Marketing for parts specified with wider operating temperature ranges.</p>				

## ELECTRICAL CHARACTERISTICS $V_{IN} = 15V, T_A = 25^\circ C$ unless otherwise noted.

SYMBOL	PARAMETER	CONDITIONS	REF-01A/E, REF-02A/E			REF-01H, REF-02H			UNITS
			MIN	TYP	MAX	MIN	TYP	MAX	
$V_O$	Output Voltage	$I_L = 0mA$	REF-01 9.97	10	10.03	REF-01H 9.95	10	10.05	V
			REF-02 4.985	5	5.015	REF-02H 4.975	5	5.025	V
	Output Adjustment Range	$R_P = 10k\Omega$	REF-01	$\pm 3$	5, -27	REF-01H	$\pm 3$	5, -27	%
			REF-02	$\pm 3$	5, -13	REF-02H	$\pm 3$	5, -13	%
$e_{nP-P}$	Output Voltage Noise	0.1Hz to 10Hz (Note 7)	REF-01	20		REF-01H	20		$\mu V_{P-P}$
			REF-02	10		REF-02H	10		$\mu V_{P-P}$
$V_{IN}$	Input Voltage Range		REF-01	12		REF-01H	12		V
			REF-02	7		REF-02H	7		V
$\frac{\Delta V_{OUT}}{\Delta V_{IN}}$	Line Regulation (Note 2)	$(V_{OUT} + 3V) \leq V_{IN} \leq 33V$		0.0001	0.010		0.0001	0.010	%/V
$\frac{\Delta V_{OUT}}{\Delta I_{OUT}}$	Load Regulation (Note 2)	$I_L = 0mA$ to 10mA	REF-01	0.0005	0.008	REF-01H	0.0005	0.010	%/mA
			REF-02	0.0010	0.010	REF-02H	0.001	0.010	%/mA
$I_Q$	Quiescent Supply Current	No Load		0.65	1.4		0.65	1.4	mA
$I_{OUT}$	Load Current Sink Current			10	20		10	20	mA
				-0.3	-20		-0.3	-20	mA
$I_{SC}$	Short-Circuit Current	$V_O = 0V$		25			25		mA
$V_T$	Temperature Voltage Output	(Note 3)	REF-02 Only	620			620		mV

**ELECTRICAL CHARACTERISTICS** $V_{IN} = 15V$ ,  $T_A = 25^\circ C$  unless otherwise noted.

SYMBOL	PARAMETER	CONDITIONS	REF-01C, REF-02C			REF-02D			UNITS
			MIN	TYP	MAX	MIN	TYP	MAX	
$V_O$	Output Voltage	$I_L = 0mA$	REF-01 REF-02	9.9 4.95	10 5	10.1 5.05	4.9 5	5.1	V V
	Output Adjustment Range	$R_P = 10k\Omega$	REF-01 REF-02	$\pm 2.7$	5, -27 5, -13		$\pm 2$	5, -13	% %
$e_{nP-P}$	Output Voltage Noise	0.1Hz to 10Hz (Note 7)	REF-01 REF-02	30 12			12		$\mu V_{P-P}$ $\mu V_{P-P}$
$\frac{\Delta V_{OUT}}{\Delta V_{IN}}$	Line Regulation (Note 2)	$(V_{OUT} + 3V) \leq V_{IN} \leq 33V$		0.0001	0.015		0.0001	0.04	%/V
$\frac{\Delta V_{OUT}}{\Delta I_{OUT}}$	Load Regulation (Note 2)	$I_L = 0mA$ to 8mA $I_L = 0mA$ to 4mA		0.0005	0.015		0.001	0.04	%/mA %/mA
$I_Q$	Quiescent Supply Current	No Load		0.65	1.6		0.65	2	mA
$I_{OUT}$	Load Current			8	20		8	20	mA
	Sink Current			-0.2	20		-0.2	20	mA
$I_{SC}$	Short-Circuit Current	$V_O = 0V$		25			25		mA
$V_T$	Temperature Voltage Output	(Note 3)	REF-02 Only	620			620		mV

The ● denotes the specifications which apply over the full operating temperature range, otherwise specifications are at  $T_A = 25^\circ C$ .  $V_{IN} = 15V$ ,  $-55^\circ C \leq T_A \leq \pm 125^\circ C$  for REF-01A/REF-02A and REF-01/REF-02,  $0^\circ C \leq T_A \leq 70^\circ C$  for REF-01E/REF-02E and REF-01H/REF-02H,  $I_L = 0mA$  unless otherwise noted.

SYMBOL	PARAMETER	CONDITIONS		REF-01A/E, REF-02A/E			REF-01H/REF-02H			UNITS
				MIN	TYP	MAX	MIN	TYP	MAX	
$\frac{\Delta V}{\Delta T}$	Output Voltage Change with Temperature (Notes 4, 5)	$0^\circ C \leq T_A \leq 70^\circ C$	●	0.02	0.06		0.035	0.17	%	
		$-55^\circ C \leq T_A \leq 125^\circ C$	●	0.09	0.15		0.144	0.45	%	
TC	Output Voltage Temperature Coefficient	(Note 6)	●	5	8.5		8	25	ppm/ $^\circ C$	
	Change in $V_O$ Temperature Coefficient with Output Adjustment	$R_P = 10k\Omega$	●	0.5			0.5		ppm/%	
$\frac{\Delta V_{OUT}}{\Delta V_{IN}}$	Line Regulation $(V_{OUT} + 3V) \leq V_{IN} \leq 33V$ (Note 2)	$0^\circ C \leq T_A \leq 70^\circ C$	●	0.0001	0.012		0.0001	0.012	%/V	
		$-55^\circ C \leq T_A \leq 125^\circ C$	●	0.0001	0.015		0.0001	0.015	%/V	
$\frac{\Delta V_{OUT}}{\Delta I_{OUT}}$	Load Regulation ( $I_L = 0mA$ to 8mA) (Note 2)	$0^\circ C \leq T_A \leq 70^\circ C$	●	0.002	0.010		0.002	0.012	%/mA	
		$-55^\circ C \leq T_A \leq 125^\circ C$	●	0.002	0.012		0.002	0.015	%/mA	
	Temperature Voltage Output Temperature Coefficient	(Note 3) REF-02	●	2.1			2.1		mV/ $^\circ C$	

# REF-01/REF-02

## ELECTRICAL CHARACTERISTICS

The ● denotes the specifications which apply over the full operating temperature range, otherwise specifications are at  $T_A = 25^\circ\text{C}$ .  $V_{IN} = 15\text{V}$ ,  $0^\circ\text{C} \leq T_A \leq 70^\circ\text{C}$  and  $I_L = 0\text{mA}$  unless otherwise noted.

SYMBOL	PARAMETER	CONDITIONS		REF-01C, REF-02C			REF-02D			UNITS
				MIN	TYP	MAX	MIN	TYP	MAX	
$\frac{\Delta V}{\Delta T}$	Output Voltage Change with Temperature	(Notes 4, 5)	●			0.45			1.7	%
TC	Output Voltage Temperature Coefficient	(Note 6)	●		8	65		8	250	ppm/°C
	Change in $V_O$ Temperature Coefficient with Output Adjustment	$R_P = 10\text{k}\Omega$	●		0.5			0.5		ppm/%
$\frac{\Delta V_{OUT}}{\Delta V_{IN}}$	Line Regulation (Note 2)	$V_{IN} = 8\text{V to } 30\text{V}$	●		0.0001	0.018		0.0001	0.05	%/V
$\frac{\Delta V_{OUT}}{\Delta I_{OUT}}$	Load Regulation (Note 2)	$I_L = 0\text{mA to } 5\text{mA}$	●		0.002	0.018		0.002	0.05	%/mA
	Temperature Voltage Output Temperature Coefficient	(Note 3) REF-02	●		2.1			2.1		mV/°C

**Note 1:** Absolute Maximum Ratings are those values beyond which the life of a device may be impaired.

**Note 2:** Line and load regulation specifications include the effect of self heating.

**Note 3:** Limit current in or out of Pin 3 to 50nA and capacitance on Pin 3 to 30pF.

**Note 4:**  $\Delta V$  is defined as the absolute difference between the maximum output voltage and the minimum output voltage over the specified temperature range expressed as a percentage of nominal output.

$$\Delta V = \left| \frac{V_{MAX} - V_{MIN}}{V_{OUT}} \right| \cdot 100$$

**Note 5:**  $\Delta V$  specification applies trimmed or untrimmed.

**Note 6:** TC is defined as  $\Delta V$  divided by the temperature range, i.e.,

$$TC = \frac{\Delta V}{T_{MAX} - T_{MIN}}$$

**Note 7:** 0.1Hz to 10Hz noise cannot be 100% tested on modern high speed test equipment, so Linear Technology does not put a guaranteed maximum specification on this parameter for standard units. 100% bench testing of 0.1Hz to 10Hz noise is available on special request. To ensure low output noise, Linear Technology *does* 100% test 10Hz to 1kHz noise. Consult factory for details.

## PACKAGE DESCRIPTION

### H Package 8-Lead TO-5 Metal Can (.230 Inch PCD) (Reference LTC DWG # 05-08-1321)

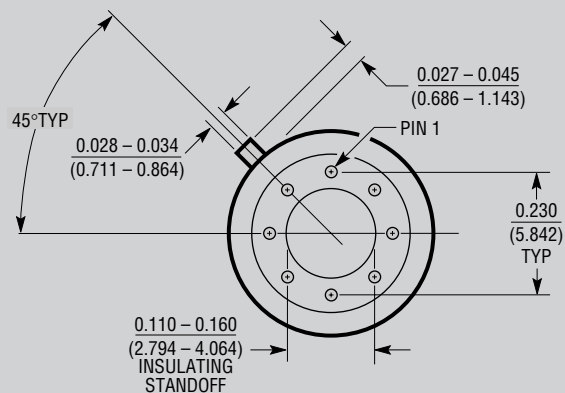
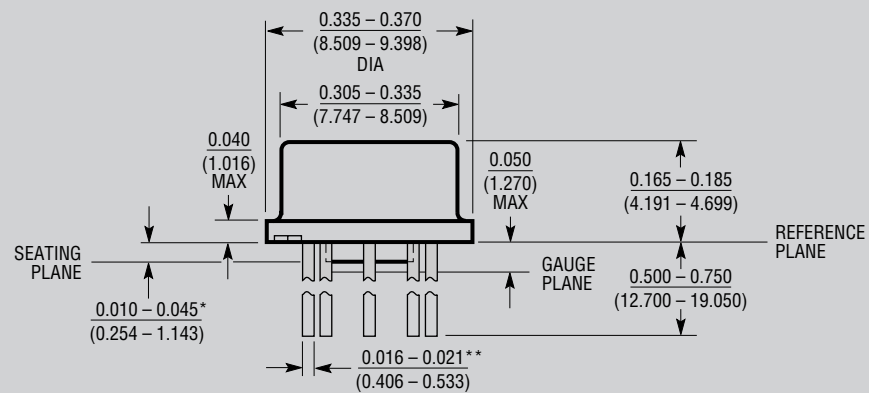

\* LEAD DIAMETER IS UNCONTROLLED BETWEEN THE REFERENCE PLANE AND 0.045" BELOW THE REFERENCE PLANE

\*\* FOR SOLDER DIP LEAD FINISH, LEAD DIAMETER IS  $0.016 - 0.024$  (0.406 - 0.610)

H8 (TO-5) 0.230 PCD 1197

## OBSOLETE PACKAGE

**PACKAGE DESCRIPTION**

**J8 Package**  
**8-Lead CERDIP (Narrow .300 Inch, Hermetic)**  
 (Reference LTC DWG # 05-08-1110)

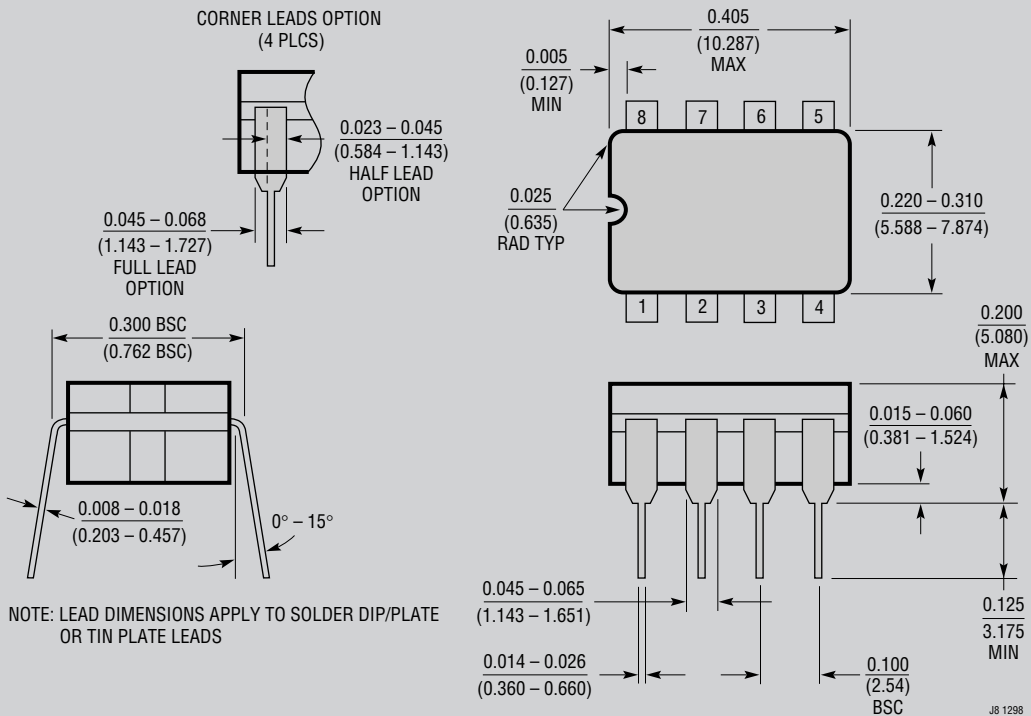

**OBsolete PACKAGE**

## PACKAGE DESCRIPTION

**N8 Package**  
**8-Lead PDIP (Narrow .300 Inch)**  
 (Reference LTC DWG # 05-08-1510)

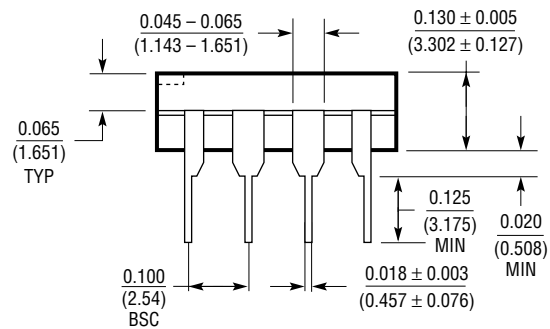
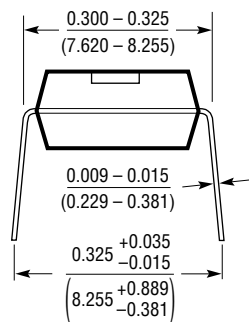
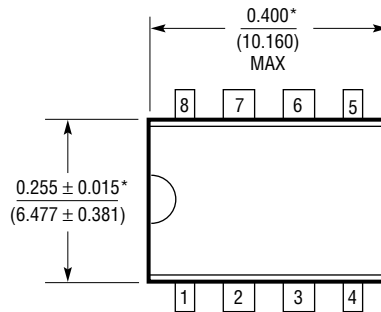

\*THESE DIMENSIONS DO NOT INCLUDE MOLD FLASH OR PROTRUSIONS.  
 MOLD FLASH OR PROTRUSIONS SHALL NOT EXCEED 0.010 INCH (0.254mm)

N8 1098

# REF-01/REF-02

---

## RELATED PARTS

PART NUMBER	DESCRIPTION	COMMENTS
LT1019	0.05%, 5ppm/°C Precision Reference	Pin Compatible with the REF-01, REF-02, Improved Specs